

LISN-MATE

1 Introduction

The TBLM1 is a companion device for LISNs, which splits the conducted noise signal into its common mode and differential mode components. The LISN Mate is connected to the output of a LISN inserted into the positive supply line and to a second LISN inserted into the negative supply line. The conducted noise signal at the output of a LISN is the sum of common mode and differential mode noise. The LISN mate splits it into the common mode and differential mode components, with each signal component available at a separate BNC port.



Picture 1: LISN mate

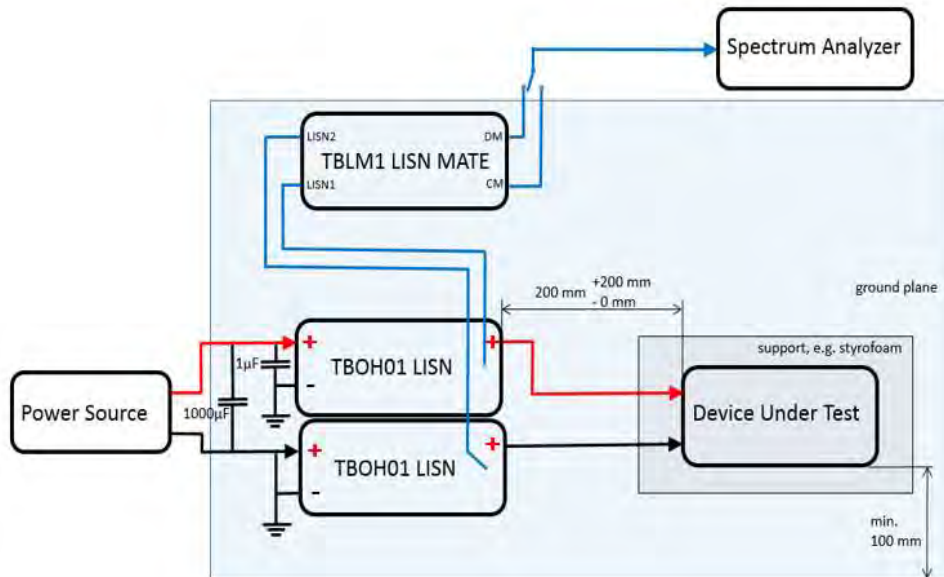

Picture 2: set up for the measurement of differential mode and common mode conducted noise
 terminate the unused LISN mate output port with 50 Ohm

LISN-MATE

2 Parameters

Frequency range: 30 kHz – 110 MHz

Maximum RF level at any BNC port: 27dBm

Maximum DC current at any BNC port: 30 mA

2.1 Frequency response

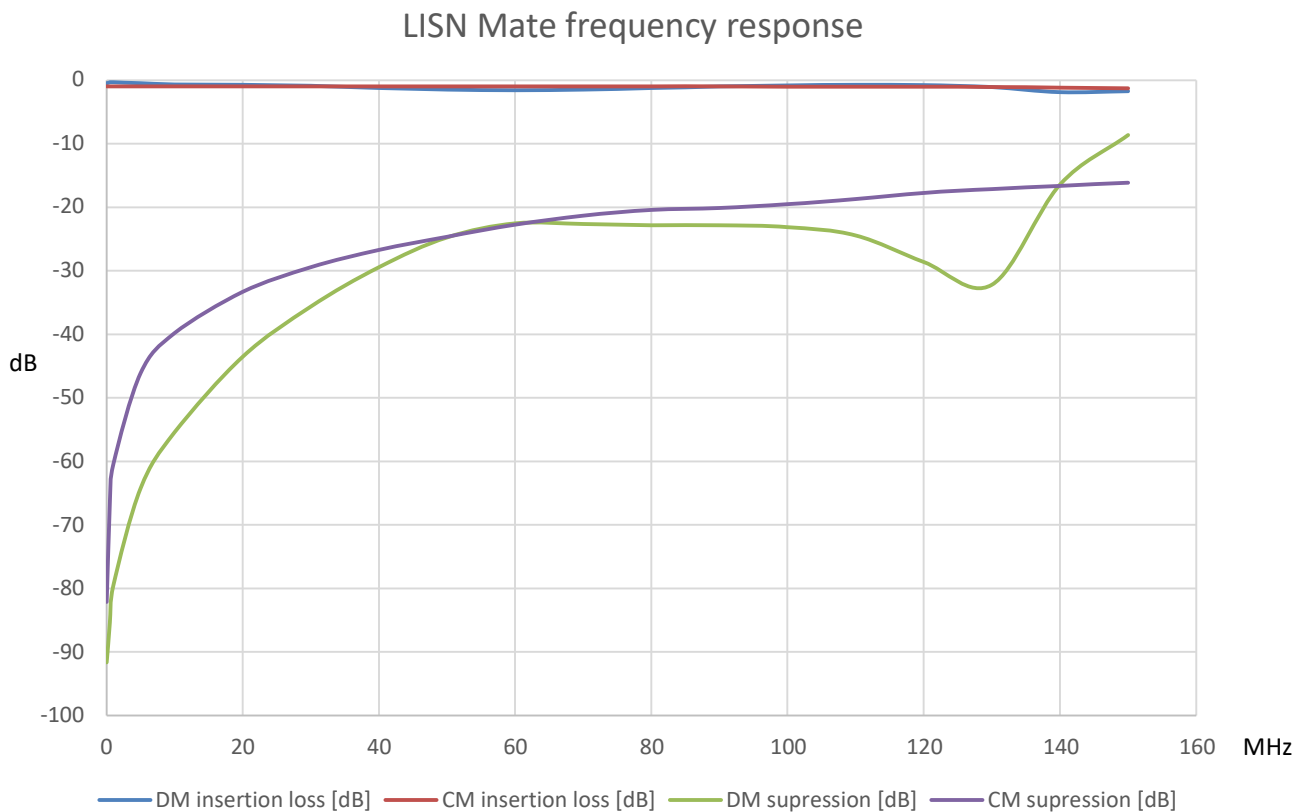

Picture 3: frequency response

Common mode insertion loss: input signal split into two same phase components and applied to LISN1 and LISN2 port; output signal measured at common mode port

Differential mode suppression: input signal split into two same phase components and applied to LISN1 and LISN2 port; output signal measured at differential mode port
 Differential mode insertion loss: input signal split into two 180° phase shift components and applied to LISN1 and LISN2 port; output signal measured at differential mode port

LISN-MATE

Common mode suppression: input signal split into two 180° phase shift components and applied to LISN1 and LISN2 port; output signal measured at common mode port

Frequency [MHz]	DM insertion loss [dB]	CM insertion loss [dB]	DM supression [dB] at CM port	CM supression [dB] at DM port
0.03	-0.45	-0.93	-91.6	-82.1
0.5	-0.31	-0.93	-85.3	-66.4
1	-0.31	-0.93	-79.5	-60.4
5	-0.46	-0.93	-64.2	-46.1
10	-0.65	-0.93	-55.4	-39.8
20	-0.69	-0.93	-43.5	-33.3
30	-0.86	-0.93	-35.6	-29.4
40	-1.21	-0.93	-29.4	-26.7
50	-1.43	-0.93	-24.7	-24.6
60	-1.54	-0.93	-22.5	-22.7
70	-1.45	-0.93	-22.6	-21.3
80	-1.22	-0.93	-22.8	-20.4
90	-0.97	-0.93	-22.8	-20.1
100	-0.81	-0.99	-23.1	-19.5
110	-0.71	-1.02	-24.4	-18.7
120	-0.74	-1.01	-28.6	-17.7
130	-1.06	-1.04	-32.2	-17.1
140	-1.85	-1.15	-16.4	-16.6
150	-1.73	-1.25	-8.6	-16.1

Table 1 – Frequency response

3 Ordering Information

Part Number	Description
TBLM1	LISN Mate, 1 piece BNC termination, 2 pieces BNC-male to BNC male cables, 35cm, RG223

Table 2 – Ordering Information

4 History

Version	Date	Author	Changes
V1.0	28.3.2018	Mayerhofer	Creation of the document
V1.1	10.10.2018	Mayerhofer	Information concerning termination of unused port added
V1.2	22.04.2020	Mayerhofer	Picture 2 updated
V1.3	11.08.2020	Mayerhofer	Section 3 Ordering Information: added BNC termination

Table 3 – History

For More Information:



Vicom Australia

1064 Centre Rd
Oakleigh South Vic 3167
Australia
1300 360 251
info@vicom.com.au
www.vicom.com.au

Vicom New Zealand

Grd Floor, 60 Grafton Road
Auckland 1010
New Zealand
+64 9 379 4596
info@vicom.co.nz
www.vicom.co.nz