



**RoHS Compliant 1550 nm Single-mode Transceiver
Small Form Pluggable (SFP+), with Diagnostic Monitoring
Fiber Channel 10G/ 10G BASE-ZW/ZR**

Features:



- Compliant with SFF-8431 and IEE802.3ae
- Data rate selectable $\leq 4.25\text{Gbps}$ or 9.95Gbps to 11.3Gbps bit rates
- Cooled EML transmitter and APD receiver
- link length up to 80km
- Low Power Dissipation 1.4W Typical (Maximum: 2W)
- -5°C to 70°C Operating Case Temperature
- Single 3.3V power supply
- Diagnostic Performance Monitoring of module temperature, supply Voltages, laser bias current, transmit optical power, receive optical power
- RoHS compliant and lead free
- Duplex LC Connector Type
- Hot Swappable
- SFP+ MSA (Multi-Source Agreement) compliance

Ordering Information

PART NUMBER	INPUT/OUTPUT	MONITOR	VOLTAGE	TEMPERATURE
CL-SFP+ ZR 80	AC/AC	YES	3.3V	-5°C to 70°C



**RoHS Compliant 1550 nm Single-mode Transceiver
Small Form Pluggable (SFP+), with Diagnostic Monitoring
Fiber Channel 10G/ 10G BASE-ZW/ZR**

Absolute Maximum Ratings

PARAMETER	SYMBOL	MIN	MAX	UNITS	NOTE
Storage Temperature	T_S	-40	85	°C	
Supply Voltage	V_{CC}	-0.5	3.8	V	
Input Voltage	V_{IN}	-0.5	V_{CC}	V	
Output Current	I_o	---	50	mA	
Operating Current	I_{OP}	---	610	mA	

Recommended Operating Conditions

PARAMETER	SYMBOL	MIN	MAX	UNITS	NOTE
Case Operating Temperature	T_C	-5	70	°C	CL-SFP+ ZR 80
Supply Voltage	V_{CC}	3.1	85	V	
Supply Current	$I_{TX} + I_{RX}$	---	250	mA	

Transmitter Electro-optical Characteristics

$V_{CC} = 3.1\text{ V to }3.5\text{ V}, T_C = 0\text{ °C to }70\text{ °C}$

PARAMETER	SYMBOL	MIN	TYP.	MAX	UNITS	NOTE
Output Optical Power (50/125 μm fiber, NA=0.20) (62.5/125 μm fiber, NA=0.275)	P_{out}	0	---	+4	dBm	
Extinction Ratio	ER	3.5	---	---	dB	
Coupled Power Ratio	CPR	9	---	---	dB	
Center Wavelength	λ_C	1528	1550	1565	nm	
Spectral Width (RMS)	$\Delta\lambda$	---	---	1	nm	
Rise/Fall Time, (20–80%)	$T_{r,f}$	---	---		ps	
Relative Intensity Noise	RIN	---	---	-128	dB/Hz	
Total Jitter	TJ	---	---	227	ps	
Output Eye						Compliant with IEEE802.3z
Max. P_{out} TX-DISABLE Asserted	P_{OFF}	---	---	-45	dBm	
Differential Input Voltage	V_{DIFF}	0.4	---	2.0	V	



**RoHS Compliant 1550 nm Single-mode Transceiver
Small Form Pluggable (SFP+), with Diagnostic Monitoring
Fiber Channel 10G/ 10G BASE-ZW/ZR**

Receiver Electro-optical Characteristics

$V_{CC} = 3.1\text{ V to }3.5\text{ V}, T_A = 0^\circ\text{C to }70^\circ\text{C} (-20^\circ\text{C to }85^\circ\text{C})$

PARAMETER	SYMBOL	MIN	TYP.	MAX	UNITS	NOTE
Optical Input Power-maximum	P_{IN}	+0.5	---	---	dBm	BER < 10^{-12}
Optical Input Power-minimum (Sensitivity)	P_{IN}	---	---	-24	dBm	BER < 10^{-12}
Operating Center Wavelength	λ_C	1510	---	1565	nm	
Optical Return Loss	ORL	12	---	---	dB	
Loss of Signal-Asserted	P_A	-12	---	---	dBm	
Loss of Signal-Deasserted	P_D	---	---	-20	dBm	
Differential Output Voltage	V_{DIFF}	0.5	---	1.2	V	
Data Output Rise, Fall Time (20–80%)	$T_{r,f}$	---	---	0.35	ns	
Receiver Loss of Signal Output Voltage-Low	RX_LOS_L	0	---	0.5	V	
Receiver Loss of Signal Output Voltage-High	RX_LOS_H	2.4	---	V_{CC}	V	



**RoHS Compliant 1550 nm Single-mode Transceiver
Small Form Pluggable (SFP+), with Diagnostic Monitoring
Fiber Channel 10G/ 10G BASE-ZW/ZR**

Block Diagram of Transceiver

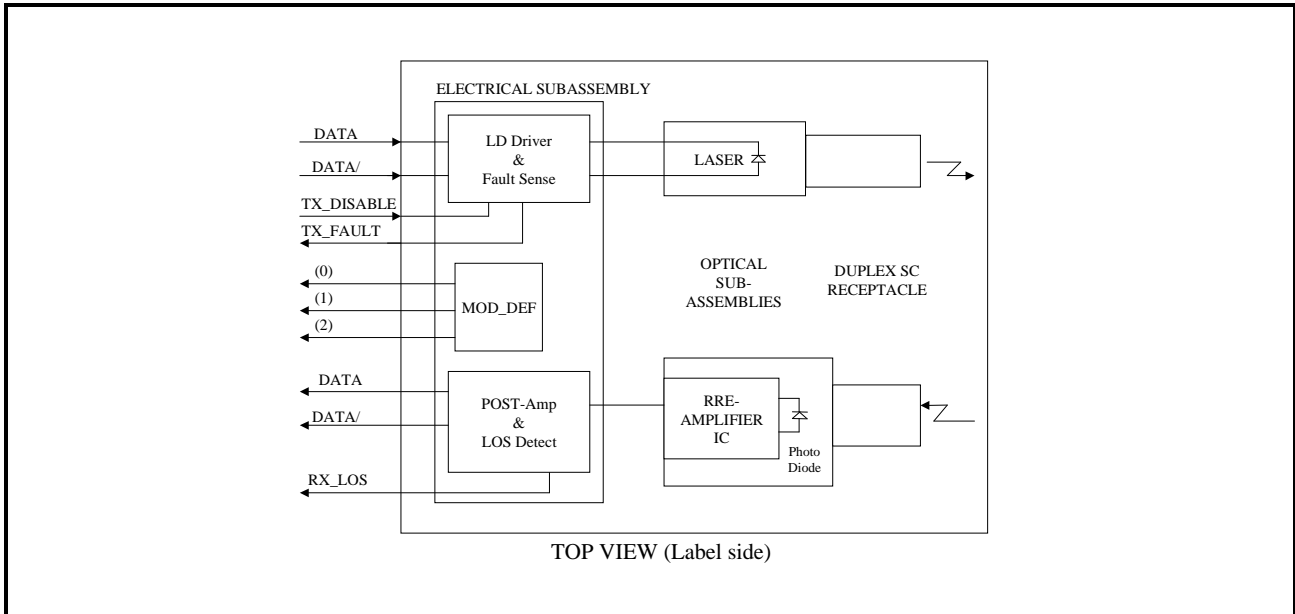

Transmitter Section

The transmitter section consists of a 1550 nm VCSEL in an eye safe optical subassembly (OSA) which mates to the fiber cable. The laser OSA is driven by a LD driver IC which converts differential input LVPECL logic signals into an analog laser driving current.

TX_FAULT

When sensing an improper power level in the laser driver, the SFP set this signal high and turns off the Laser. TX_FAULT can be reset with the TX_DISABLE line. The signal is in TTL level.

TX_DISABLE

The TX_DISABLE signal is high (TTL logic "1") to turn off the laser output. The laser will turn on within 1ms when TX_DISABLE is low (TTL logic "0").

Receiver Section

The receiver utilizes a MSM detector integrated with a trans-impedance preamplifier in an OSA. This OSA is connected to a circuit providing post-amplification quantization, and optical signal detection.

Receive Loss (RX_LOS)

The RX_LOS is high (logic "1") when there is no incoming light from the companion transceiver. This signal is normally used by the system for the diagnostic purpose. The signal is operated in TTL level.



**RoHS Compliant 1550 nm Single-mode Transceiver
Small Form Pluggable (SFP+), with Diagnostic Monitoring
Fiber Channel 10G/ 10G BASE-ZW/ZR**

Dimensions:

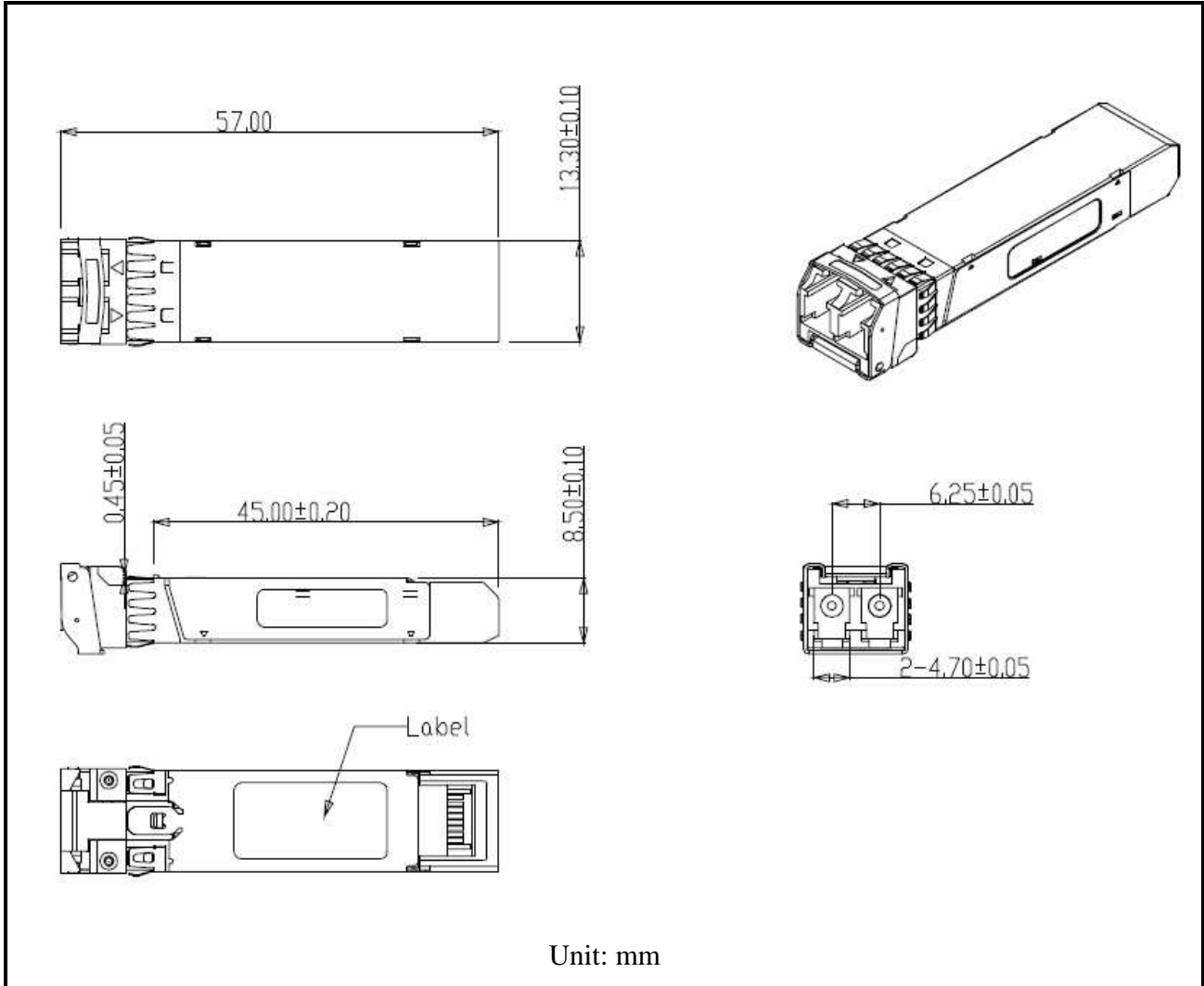



**RoHS Compliant 1550 nm Single-mode Transceiver
Small Form Pluggable (SFP+), with Diagnostic Monitoring
Fiber Channel 10G/ 10G BASE-ZW/ZR**

SFP host board mechanical layout :

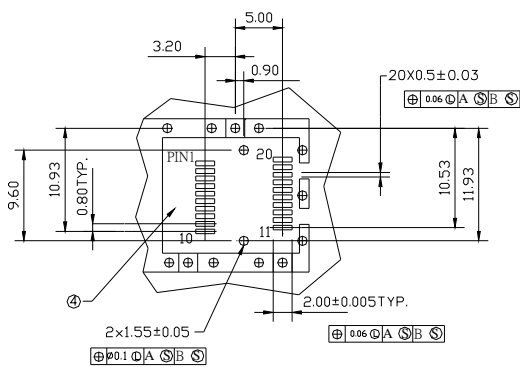
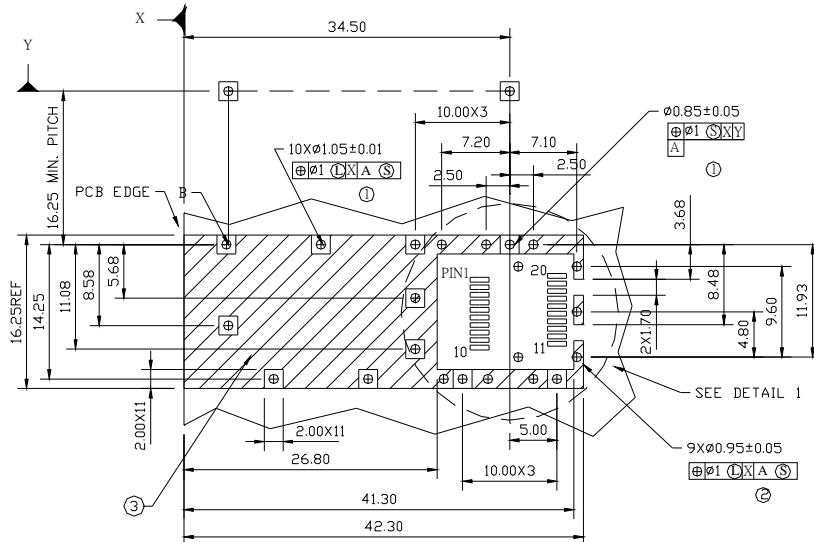

DETAIL 1

LEGEND

- 1.PADS AND VIAS ARE CHASSIS GROUND
- 2.THROUGH HOLES, PLATING OPTIONAL
- 3.HATCHED AREA DENOTES COMPONENT AND TRACE KEEPOUT(EXCEPT CHASSIS GROUND)
- 4.AREA DENOTES COMPONENT KEEPOUT (TRACES ALLOWED)

DIMENSIONS ARE IN MILLIMETERS

Unit: mm



**RoHS Compliant 1550 nm Single-mode Transceiver
Small Form Pluggable (SFP+), with Diagnostic Monitoring
Fiber Channel 10G/ 10G BASE-ZW/ZR**

Assembly drawing

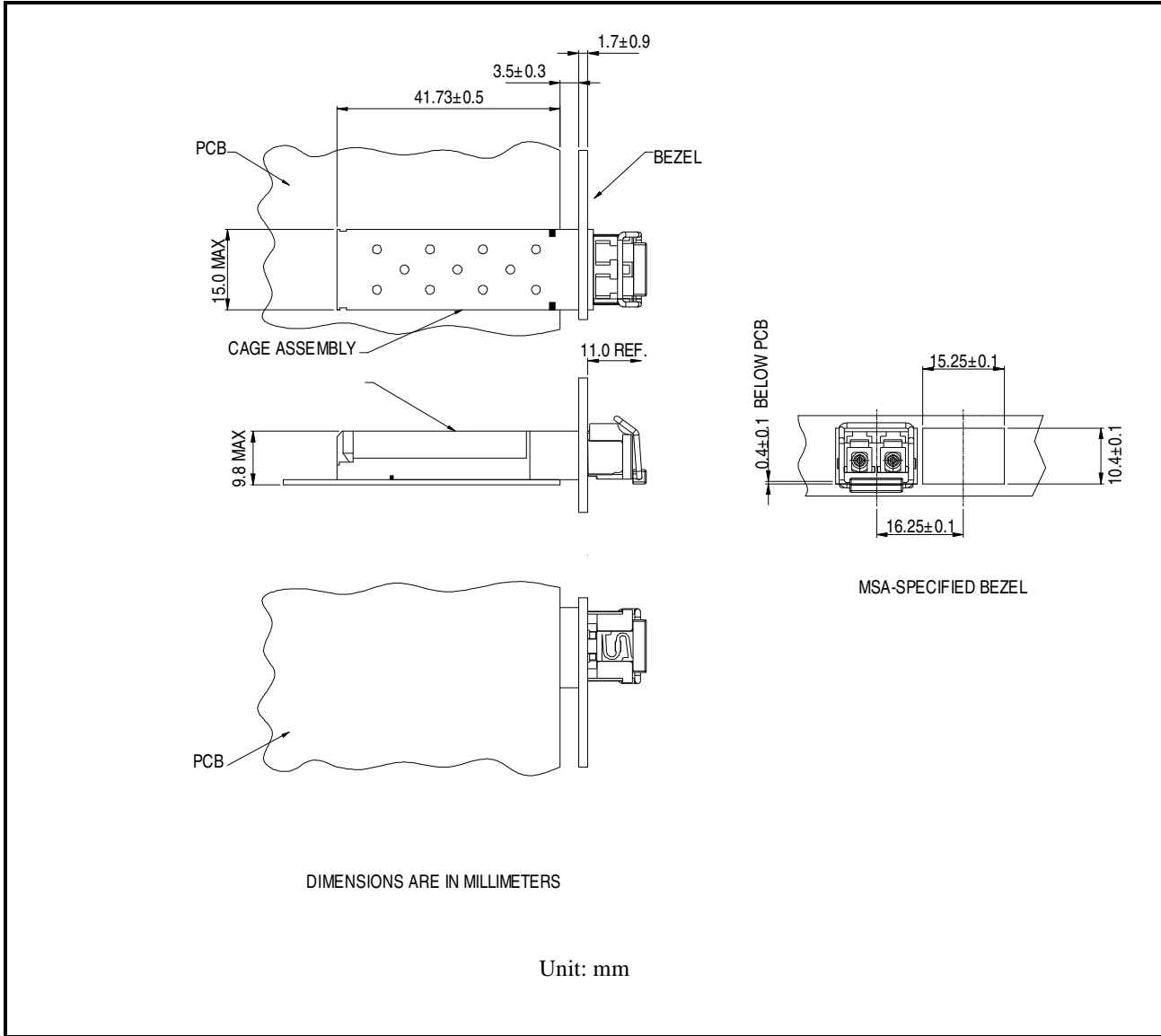



**RoHS Compliant 1550 nm Single-mode Transceiver
Small Form Pluggable (SFP+), with Diagnostic Monitoring
Fiber Channel 10G/ 10G BASE-ZW/ZR**

Pin Assignment

Pin-Out

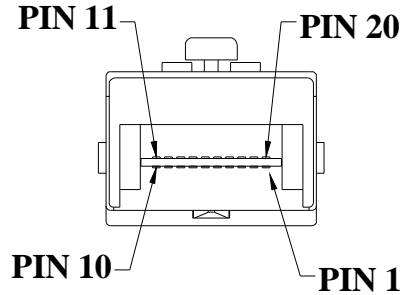

Pin	Signal Name	Description
1	T_{GND}	Transmit Ground
2	TX_FAULT	Transmit Fault
3	$TX_DISABLE$	Transmit Disable
4	$MOD_DEF (2)$	SDA Serial Data Signal
5	$MOD_DEF (1)$	SCL Serial Clock Signal
6	$MOD_DEF (0)$	TTL Low
7	$RATE_SELECT$	Open Circuit
8	RX_LOS	Receiver Loss of Signal, TTL High, open collector
9	R_{GND}	Receiver Ground
10	R_{GND}	Receiver Ground
11	R_{GND}	Receiver Ground
12	$RX-$	Receive Data Bar, Differential PECL, ac coupled
13	$RX+$	Receive Data, Differential PECL, ac coupled
14	R_{GND}	Receiver Ground
15	V_{CCR}	Receiver Power Supply
16	V_{CCT}	Transmitter Power Supply
17	T_{GND}	Transmitter Ground
18	$TX+$	Transmit Data, Differential PCEL, ac coupled
19	$TX-$	Transmit Data Bar, Differential PCEL, ac coupled
20	T_{GND}	Transmitter Ground



**RoHS Compliant 1550 nm Single-mode Transceiver
Small Form Pluggable (SFP+), with Diagnostic Monitoring
Fiber Channel 10G/ 10G BASE-ZW/ZR**

Eye Safety Mark

The SFP series multimode transceiver is a class 1 laser product. It complies with EN 60825-1 and FDA 21 CFR 1040.10 and 1040.11. In order to meet laser safety requirements the transceiver shall be operated within the Absolute Maximum Ratings.

Caution

All adjustments have been done at the factory before the shipment of the devices. No maintenance and user serviceable part is required. Tampering with and modifying the performance of the device will result in voided product warranty.

Required Mark

**Class 1 Laser Product
Complies with
21 CFR 1040.10 and 1040.11**

Note : All information contained in this document is subject to change without notice.