

**EXTRACT**  
**PRIME**  
*mini* **EC** **4in1**

*Bathroom Heater, Fan, Light & Exhaust*

Installation Manual

# IMPORTANT

We strongly recommend that you read this manual carefully before installation. Installation MUST be carried out by a qualified and licensed electrician. This unit must be installed to comply with the appropriate council regulations and the Australia and New Zealand wiring rules AS/NZS3000 and relevant amendments.

## For your safety

1. Use this heater only as described in this manual. The manufacturer does not recommend any other use as this may cause fire, electric shock, or injury to persons. If you have questions, contact Vencha.
2. Make sure the mains is off before the installation.
3. When cutting into the ceiling, do not damage electrical wiring and other hidden utilities.
4. The heater must be properly grounded.
5. The heating element is extremely hot when in use. Do not touch the heat element at any time during operation and if turned off, allow for one hour to pass, and element to cool down.
6. To avoid any dangerous gas leaking into your bathroom, the ventiduct of the heater must not be laid together with the ventiduct of air-fuelled water heater or other open-fire appliances into the same flue.
7. The power cable must stand a minimum 10A load. Cables required for installation of this unit are not included.
8. The appliance is not intended for use by persons (including children) with reduced physical, sensory or mental capabilities, or lack of experience and knowledge, unless under supervision by a person responsible for their safety. The heater must be installed where switches and control cannot be touched by a person in the bath or shower.
9. The appliance shall, under no circumstances, be covered with insulating material or similar material.
10. Regulations concerning the discharge of air must be fulfilled.
11. Joists, beams and rafters shall not be cut or notched to install the appliance.
12. This product has been designed for INDOOR domestic or similar uses and is not suitable for a commercial installation. It is not suitable for use in an environment heavily laden with dust and/or corrosive areas. Under these conditions the life of the fan motor can be significantly reduced.
13. Heat function should not be operated for more than 40 minutes continuously, turn off when not in use.

## IMPORTANT INFORMATION BEFORE INSTALLATION

1. The unit should not be installed directly above a shower or bathtub.
2. The unit must not be installed beneath a fixed socket or power outlet.
3. The unit must be installed on flat level surface. Do not mount it on a sloping ceiling or a vertical wall. The heat lamp is most effective when you are standing directly beneath them, so generally the unit would be mounted a place where you would stand to dry yourself.
4. In high steam conditions, use the heat function and exhaust function together to reduce humidity.
5. For the exhaust fan to work efficiently, replacement air of a volume equivalent to what is being extracted must be able to enter the room.

**NB: Generally, this air would be drawn under the door, or through a slightly open window.**

**If the room is airtight, the fan will function poorly.**

6. Before commencing any cutting, check in the ceiling space that there are no obstructions such as ceiling joists and that there is sufficient height clearance for the housing. Check that the electrical wiring can be routed from the wall switches to the mounting location.

Specifications	
Model	Extract Prime Mini
Code	5501024
Voltage	220-240v, 50Hz
Light	1 x 12w LED
Fan/Exhaust Power	20w
Total Power	2032w
Duct Outlet Size	100mm (D)
Protection Class	IPX4

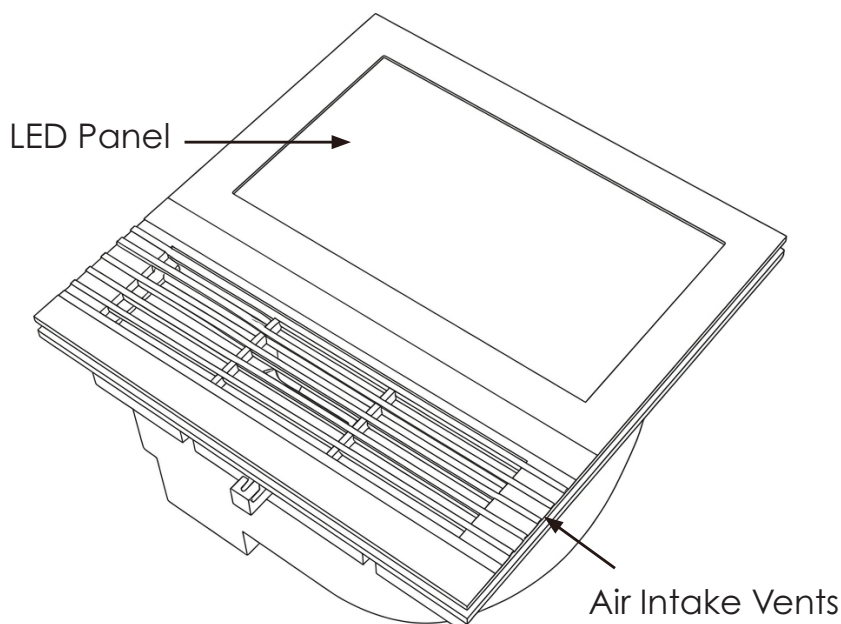

## Clearance Requirements

- This unit must be mounted at least 250mm away from vertical walls.
- This unit must have a minimum clearance of 100mm above the top of the unit.
- This unit must have a minimum clearance of 75mm between sides of unit and joists, walls or insulation.

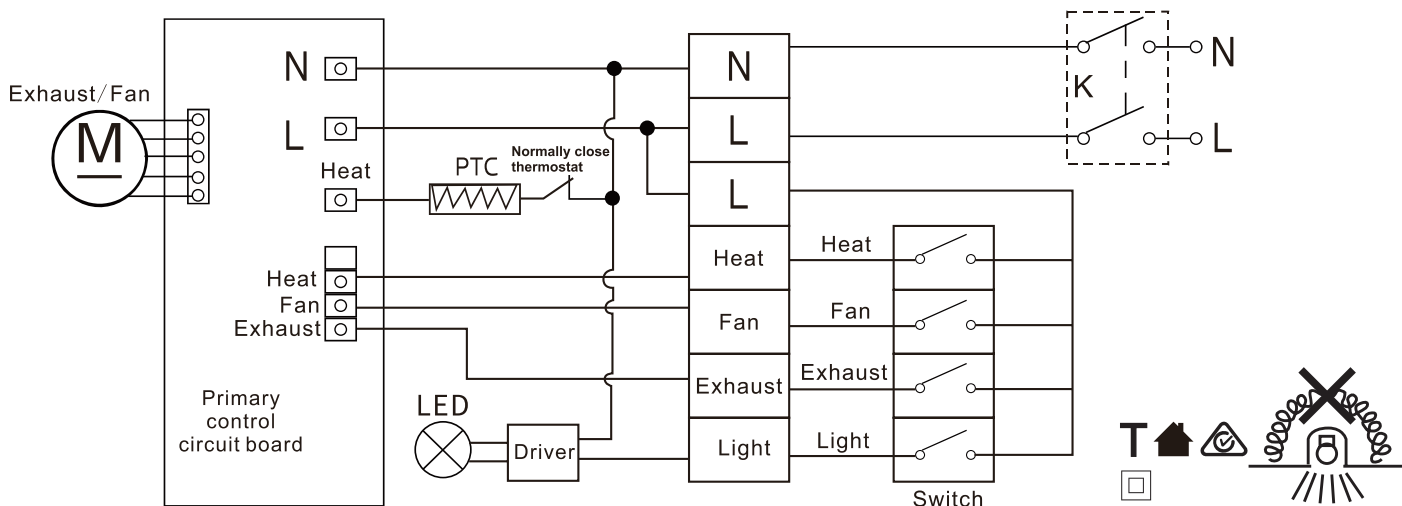

# Installation

1. Use a pencil and trace around the template supplied in the package

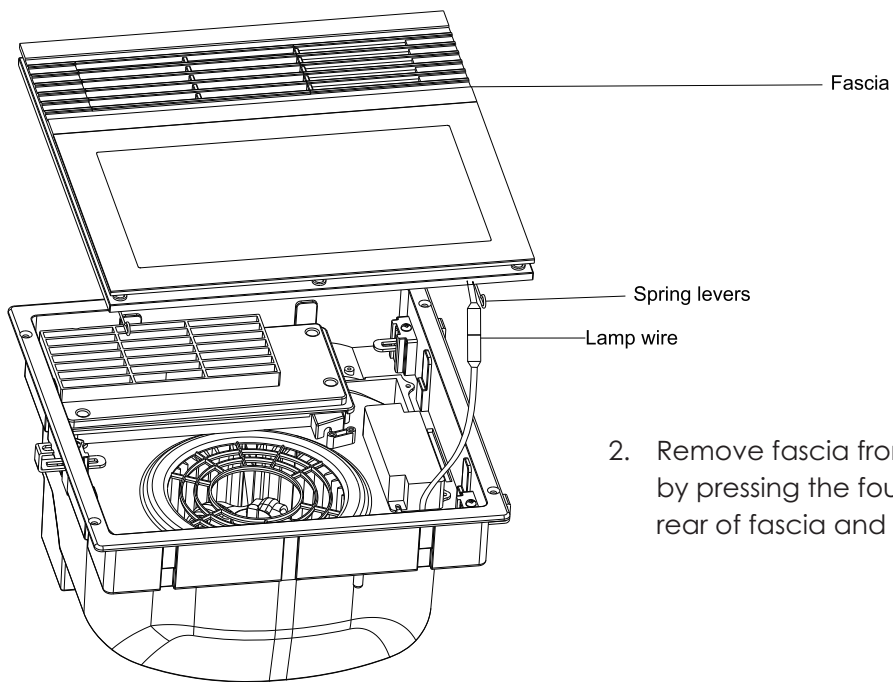
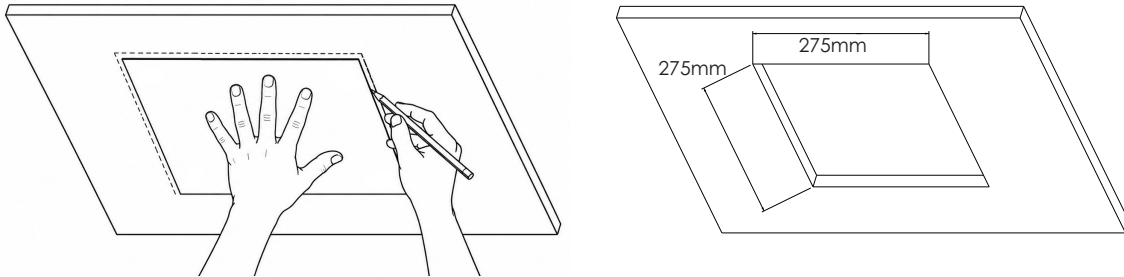

2. Remove fascia from the main unit with care by pressing the four spring levers attached to rear of fascia and disconnect lamp wire

3. Remove wiring box cover to access terminal block

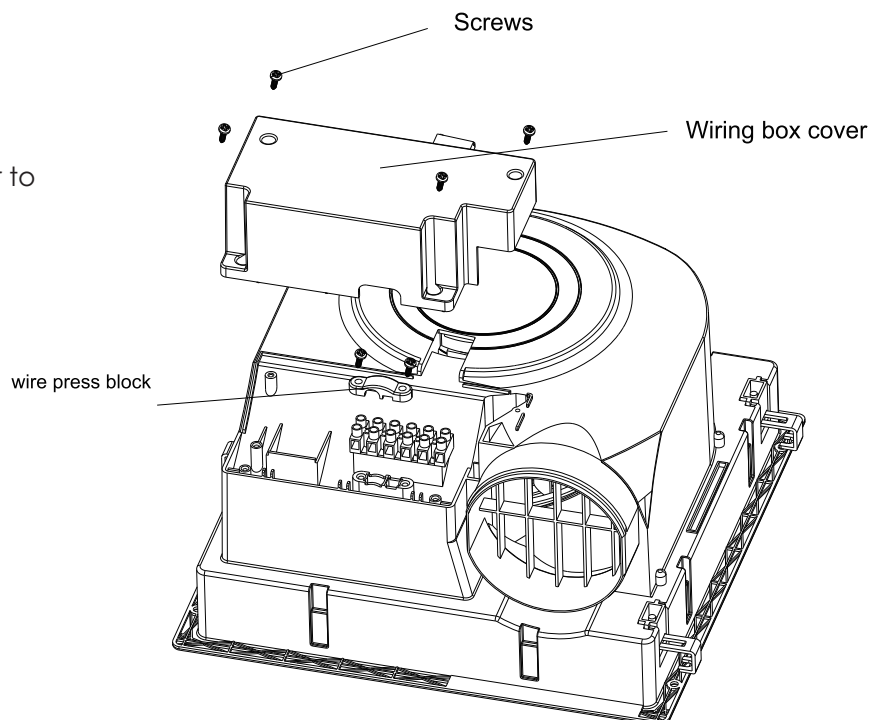

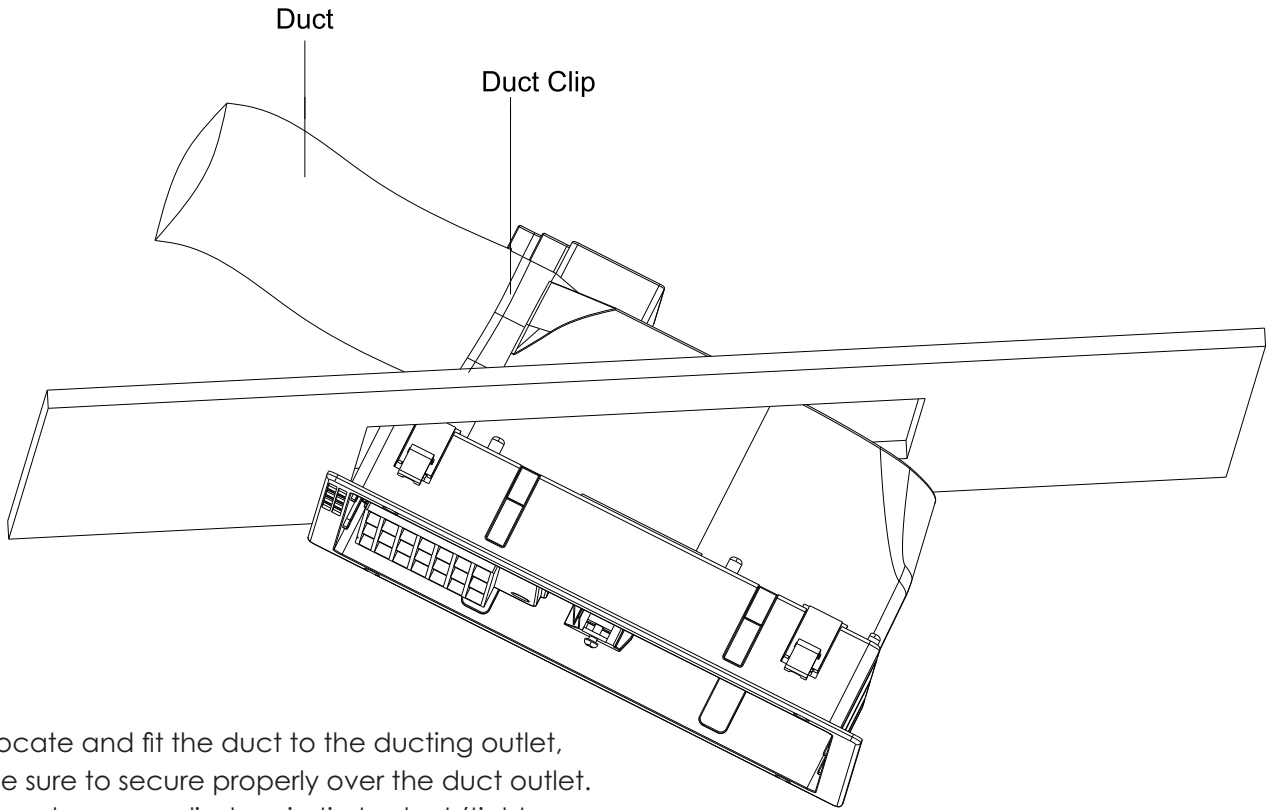

4. Locate and fit the duct to the ducting outlet, be sure to secure properly over the duct outlet. Use clamp supplied or zip tie to duct (tighten so that it will not come off during operation).

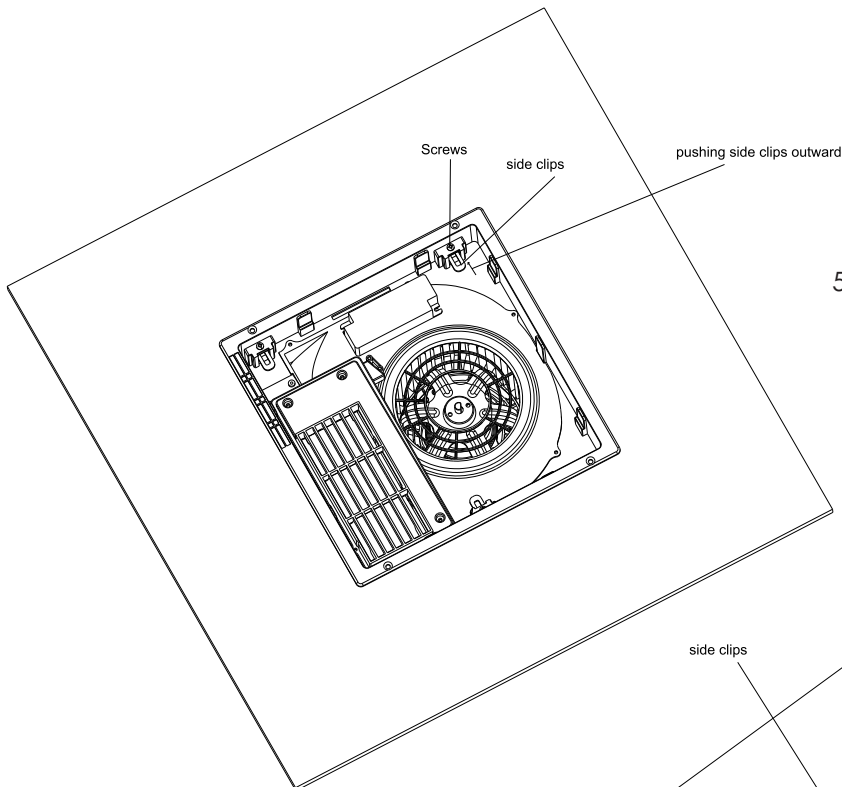

5. Ensure the unit is held securely in place by revolving side clips Clockwise and tighten the four screws until main unit rests flush to the ceiling

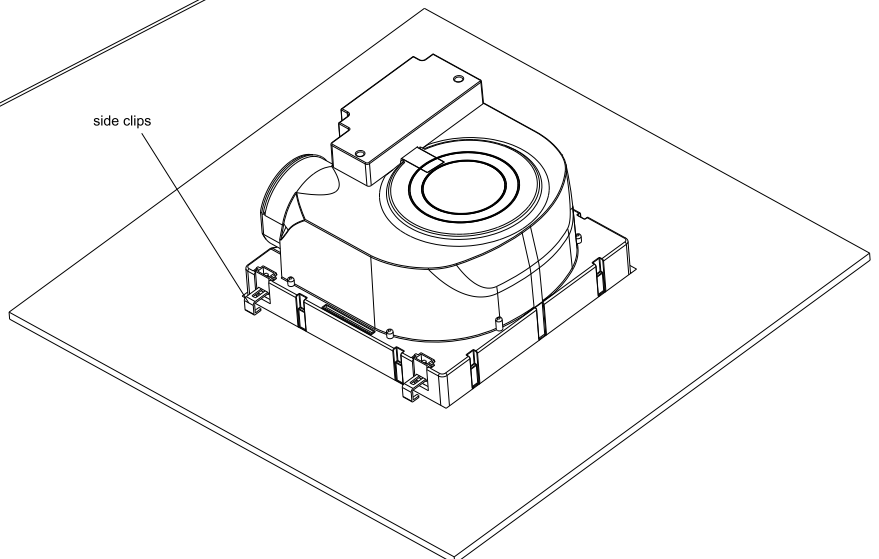

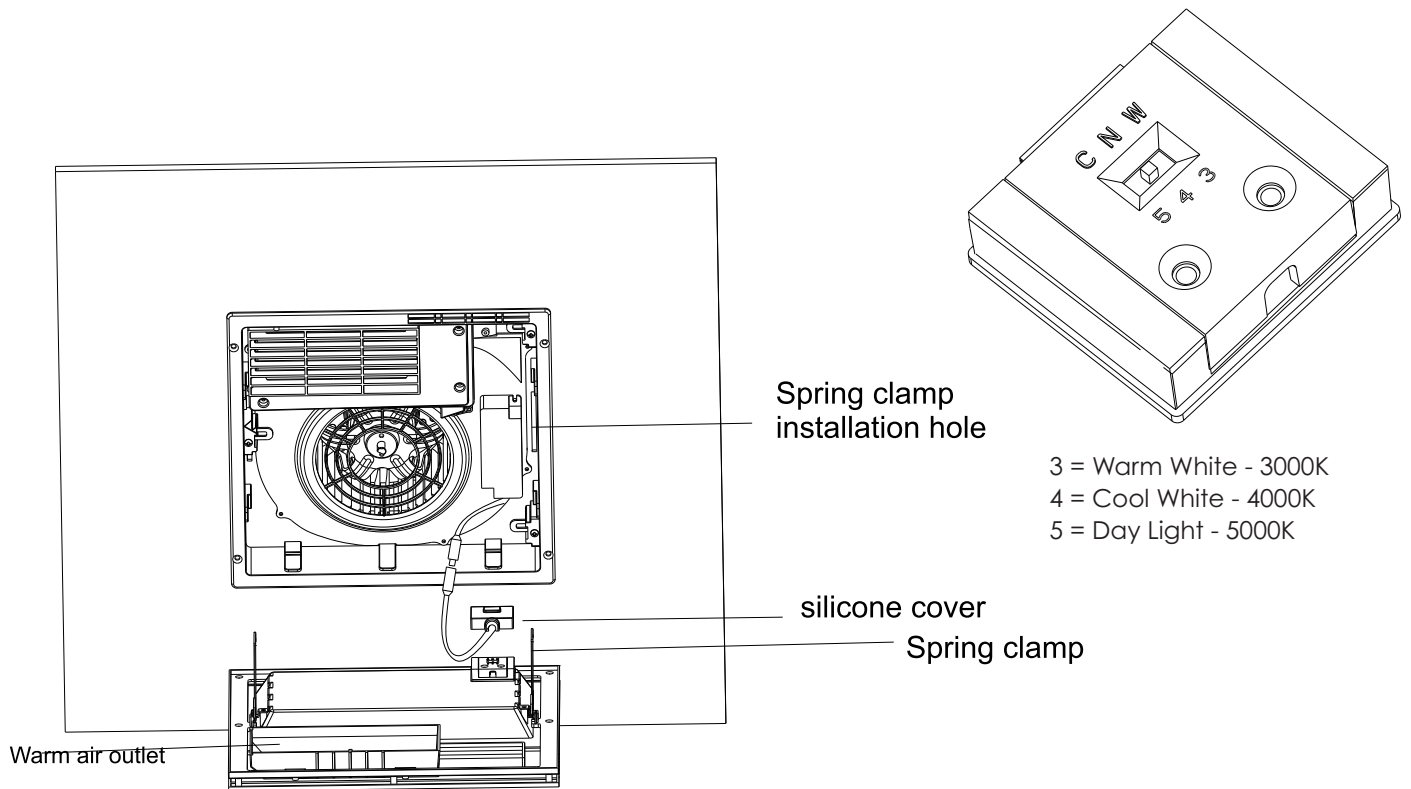

- Remove the silicone cover on the switch, select a light colour for LED panel by the sliding behind the panel, put the silicone cone cover back on the switch in same way. Connect LED light power connector with driver output connector.

**WARNING: Warm air outlet must align with the special grill with heat-resistant materials. Re-install fascia to main unit by squeezing four safety spring wires/clips together and slot them into the spring wire slow on main unit. Align fascia with main unit before pushing it in. Make sure the LED panel connector and cable are not pressed by other components. Place whole fascia securely with main unit. Before first use, turn on heater and fan for at least 5 minutes to eliminate any lingering odour**

# OPERATING INSTRUCTIONS

## Heat

- Press the Heat button to turn the heat function on or off.
- When the heat function is turned off, the heating element will switch off immediately. The fan will continue to run for approximately 20 seconds as part of the cool-down cycle.
- For safety, the heat function will automatically turn off after 45 minutes of continuous operation.
- If Heat button is selected while Exhaust is active, Heat will not work. Heat will only work when Exhaust button is turned off. If Exhaust has been turned off, it will need to complete 2-minute run on timer function before heat is activated.

## Fan

- Press the Fan button to turn the cooling fan on or off.
- When operating, air will blow out from the unit to provide cooling airflow.

## Light

- Press the Light button to turn the light on or off.
- The 3CCT colour temperature selector is located inside the unit. To change the light colour, remove the fascia and toggle the selector to the desired setting.

## Exhaust

- Press the Exhaust button to turn the exhaust function on or off.
- Exhaust will override Heat button, heat will stop, fan will still continue for 20 seconds, before stopping and converting to exhaust mode.
- For maximum performance, ensure there is sufficient air intake into the room, such as through a gap under the door, an open window, or an air vent.
- After being turned off, the exhaust fan will continue to run for approximately 2 minutes to help remove condensation and reduce the risk of mould growth.

# CARE AND MAINTENANCE

- Ensure the product is switched off before carrying out any maintenance.
- If the product has recently been used, allow sufficient time for it to cool down before cleaning or maintenance.
- To remove the fascia, gently pull it downwards. This will expose four retaining springs. Carefully press the springs together to release them from the slots.
- While removing the fascia, disconnect the LED light plug.
- Using a vacuum with a soft brush attachment, gently clean the fascia to remove any build-up of dust.
- Wipe the fascia with a damp cloth for final cleaning. Do not use abrasive cleaners, solvents, or harsh chemicals.
- While the fascia is removed, use the vacuum with a soft brush attachment to lightly clean inside the unit and remove any dust build-up.
- Ensure the fascia is completely dry before refitting.
- Reconnect the LED light plug, then carefully reattach the fascia to the unit, ensuring the retaining springs are securely positioned back into the slots.

# WARRANTY

This product is warranted against manufacturing defects and defects in workmanship for the following periods from the date of purchase:

- **Motor:** 5 years
- **Lighting components:** 2 years
- **In-home labour warranty:** 2 years

This product is intended for domestic use only and is not suitable for commercial applications. Use in a commercial setting may void the warranty.

This warranty covers manufacturing defects only. It does not cover damage or faults caused by incorrect installation, misuse, neglect, modification, normal wear and tear, accidental damage, use in unsuitable environments, failure to follow the instructions in this manual, or installation that does not comply with applicable electrical, building, or ventilation regulations.

The 2 year in-home labour warranty applies to approved domestic warranty claims only. Where a valid claim is accepted within the in-home labour warranty period, Vencha may arrange service at the installation address, where reasonably accessible. This labour warranty does not cover costs associated with gaining access to the product, removal or reinstatement of ceiling materials, damage caused by installation issues, or any work required to rectify non-product-related faults.

Before installation, check all components for visible damage. If any damage is found, do not install the product and contact Vencha or the place of purchase.

Installation must be completed by a licensed electrician in accordance with all applicable regulations. Proof of installation, including the relevant electrical safety certificate or certificate of compliance, may be required for warranty claims. Warranty claims may be rejected if the required installation documentation cannot be provided.

To submit a warranty claim, visit [www.vencha.net.au](http://www.vencha.net.au) and complete the Warranty Claim Form.

Warranty claims may require the following information:

- Proof of purchase
- Product model number and details
- Description of the fault
- Photos or videos showing the fault, where requested
- Owner's name, address, and contact details
- Installation address
- Electrical safety certificate or certificate of compliance, where applicable

Where a valid warranty claim is accepted, Vencha may, at its discretion, repair the product, supply replacement parts, arrange service under the in-home labour warranty, or provide a replacement product of the same or comparable model.

## **AUSTRALIAN CONSUMER LAW**

Our goods and services come with guarantees that cannot be excluded under the Australian Consumer Law. For major failures with the service, you are entitled to cancel your service contract with us and to a refund for the unused portion, or to compensation for its reduced value. You are also entitled to choose a refund or replacement for major failures with goods. If a failure with the goods or service does not amount to a major failure, you are entitled to have the failure rectified in a reasonable time. If this is not done, you are entitled to a refund for the goods and to cancel the service contract and obtain a refund of any unused portion. You are also entitled to compensation for any other reasonably foreseeable loss or damage from a failure in the goods or service.

The benefits provided under this warranty are in addition to any other rights and remedies available to you under the Australian Consumer Law.



1/6 Boden Rd

Seven Hills, NSW 2147

**P:** (02) 8811 1622

**E:** [warranties@vencha.net.au](mailto:warranties@vencha.net.au)

**W:** [www.vencha.net.au](http://www.vencha.net.au)