

Light Equipment Shelf

Product Information

This shelf mounts directly to the front of the 19" vertical rails and can support loads up to 10 kg. Ideal for smaller non-rack mountable devices.

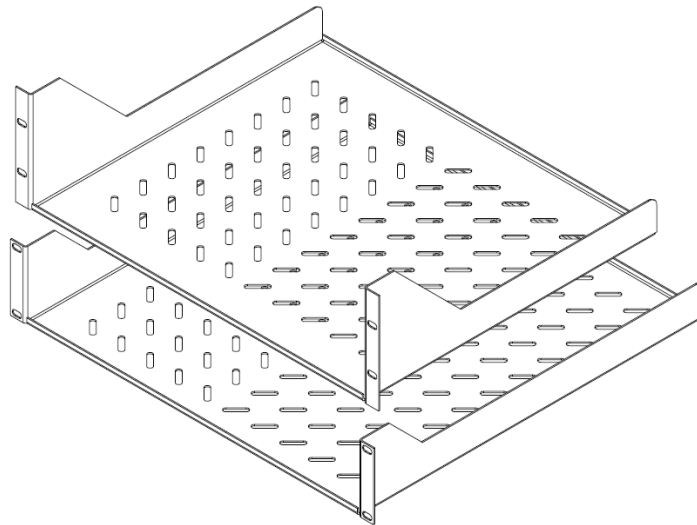

Part Number	Part Description
ERA006	Light Equipment Shelf

Features

- EIA - 310E 19" Standard
- Easy to install to the front of the 19" vertical rails
- RoHS compliant

Material / Finish

- High grade cold rolled steel 1.2mm thickness
- Powder coat finish preceded by 5 stage iron phosphate pre-treatment
- Standard colour is low gloss black.
- Special colours up on request

Dimensions (in mm.)

A – 330

B – 88

C – 76

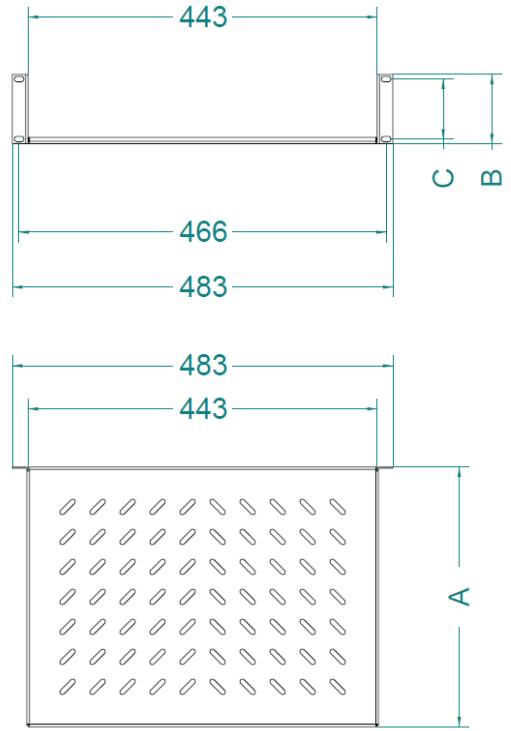

Application and Installation

Contents of KIT:

Item	Part Name	Qty
1	Light Equipment Shelf	1
2	Washer M6 Black (Plastic Cup)	4
3	Pan Head Screw M6-16	4
4	Caged Nut M6 14-16 SWG	4

