

Eaton 9PX Gen2

Advanced User Guide



9PX5KIRTG2
9PX6KIRTG2
9PX8KIRTG2
9PX11KIRTG2

9PXEBM180RT3UG2
9PXEBM240RT3UG2

MBP6KIG2
MBP11KIG2

Table of Contents

1	Special symbols.....	1
2	Introduction.....	2
2.1	Environmental protection	2
	Substances	2
	Packaging	2
	End of life	3
	Product.....	3
	Battery	3
2.2	Benefits.....	3
3	Presentation	4
3.1	Weights and dimensions	4
3.2	Rear panel	5
	UPS Rear Panels.....	5
	EBM Rear Panels	6
3.3	Optional accessories.....	8
4	Installation	9
4.1	Inspecting the equipment	9
	UPS Package content	9
	EBM Package content.....	9
4.2	Unpacking the UPS.....	11
4.3	Recommended positions.....	12
	Installation in tower position	12
	Installation in rack position.....	12
4.4	EBM connection	15
4.5	UPS connection	18
	Hardwired connection.....	18
4.6	Register warranty	24
4.7	Connection with MBP.....	24
	MBP electrical connection	28
	Recommended cable cross-sections for standard installation.....	29
	Connection between MPB and UPS.....	30
	Power up your installation	31
5	Interfaces and communication	32
5.1	Control panel.....	32
	Led indicator.....	32
5.2	LCD description	33
5.3	Display functions.....	34
5.4	User settings	35
5.5	Advanced Battery Management +	39

5.6	Communication ports.....	39
5.7	UPS remote control functions.....	41
	Programmable signal inputs.....	41
	Programmable signal outputs.....	43
5.8	Eaton Intelligent Power Software suite.....	44
5.9	Cybersecurity.....	44
6	Operation.....	45
6.1	Start-up and normal operation.....	45
6.2	Starting the UPS on battery.....	45
6.3	UPS start-up with HotSwap MBP.....	46
6.4	UPS shutdown.....	47
6.5	Operating modes.....	47
	Normal mode.....	47
	Battery mode.....	47
	Low-battery warning.....	47
	Low-battery warning.....	47
	End of battery backup time.....	47
	Bypass mode 	47
6.6	Return of AC input power.....	48
6.7	Configuring battery settings.....	48
6.8	Setting high efficiency mode.....	48
7	UPS maintenance.....	49
7.1	Equipment care.....	49
7.2	Storing the equipment.....	49
7.3	When to replace batteries.....	49
	Preventive Mode.....	49
	Predictive Mode (ABM+).....	49
7.4	UPS replacement with HotSwap MBP.....	50
	MBP6KiG2.....	50
	MBP11KiG2:.....	51
	Return to normal operation:.....	52
7.5	UPS Maintenance with HotSwap MBP.....	53
7.6	Recycling the used equipment.....	53
8	Troubleshooting.....	54
8.1	Typical alarms and faults.....	54
8.2	Silencing the alarm.....	56
8.3	Service and support.....	56
9	Specification and technical characteristics.....	57
9.1	UPS model list.....	57
9.2	Extended Battery Module model list.....	57
9.3	Electrical input.....	58

9.4	Electrical input connections.....	58
9.5	Electrical output	59
9.6	Electrical output connection	59
9.7	Battery	60
9.8	Environmental and safety.....	60
	China RoHS2-HST (Cd free).....	62
10	Glossary	63

1 Special symbols

The following are examples of symbols used on the UPS or accessories to alert you to important information:



DANGER: Dangerous voltage levels are present within the UPS. The UPS has its own internal power source (the battery). Consequently, the power outlets may be energized even if the UPS is disconnected from the AC power source.



Important instructions that must always be followed.

CAUTION: Batteries present a risk of energy or electrical shock or burn from high short circuit current. Observe proper precaution. Batteries may contain HIGH VOLTAGE and CORROSIVE, TOXIC and EXPLOSIVE substances.



Information, advice, help.



Read the documentation provided.



Disconnect input plug.



Before maintenance, first shut down the UPS then disconnect the AC power source, internal and external batteries then discharge capacitors by pressing the ON button and wait 5 minutes.



This equipment should only be used in a dry indoor environment.



Operating range of temperature.



Operating range of humidity.



The UPS and their batteries must be kept in a ventilated place.



USB Communication Port



Alternating Current (AC)



Direct Current (DC)

2 Introduction

Thank you for selecting an Eaton 9PX G2 product to protect your electrical equipment.

The Eaton 9PX G2 range has been designed with the utmost care. We recommend that you take the time to read this advanced user guide to take full advantage of the many features of your UPS (Uninterruptible Power System).

Before installing your Eaton 9PX G2, please read the information and safety instructions provided. Follow the instructions in the quick start guide and if necessary, refer to this advance user guide.

To discover the entire range of Eaton products, we invite you to visit our web site at eaton.com or contact your Eaton local representative.



Warning: Operation of this equipment in a residential environment could cause radio interference.



Warning: This is a category C2 UPS product. In a residential environment, this product may cause radio interference, in which case the user may be required to take additional measures.

2.1 Environmental protection

Eaton has implemented an environmental-protection policy. Products are developed according to an eco-design

approach.

Substances

This product contains no CFC, HCFC or asbestos. This product is compliant with regulations on the restriction of the use of substances in electrical and electronic equipment.

Packaging

To improve waste treatment and facilitate recycling, separate the various packing components.

- Packing materials are recyclable and bear the appropriate identification symbol. 
- The cardboard we use comprises over 50% of recycled cardboard.
- Plastic bags are made of polyethylene.

Materials	Abbreviations	Number in the symbols 
Polyethylene terephthalate	PET	01
High-density polyethylene	HDPE	02
Polyvinyl chloride	PVC	03
Low-density polyethylene	LDPE	04
Polypropylene	PP	05
Polystyrene	PS	06

Follow all local regulations for the disposal of packing materials.

End of life

Eaton will process products at the end of their service life in compliance with local regulations. Eaton works with companies in charge of collecting and eliminating our products at the end of their service life.

Product

The product is made from materials that can be recycled. Dismantling and destruction must take place in compliance with all local regulations concerning waste. At the end of its service life, the product must be transported to a processing center for electrical and electronic waste. eaton.com/recycling

Battery

The product contains lead-acid batteries that must be processed according to applicable local regulations concerning batteries. The battery may be removed to comply with regulations and in view of correct disposal.

2.2 Benefits

The Eaton 9PX Gen2 uninterruptible power system (UPS) protects your sensitive electronic equipment from the most common power problems, including power outages, voltage sags, impulsive transients, line noise, and long-term under and over voltage conditions, frequency variations, switching transients, and harmonic distortion.

With the Eaton 9PX Gen2, you can safely eliminate the effects of power disturbances and guard the integrity of your equipment. Providing outstanding performance and reliability, the Eaton 9PX Gen2's unique benefits include:

- True online double-conversion technology with high power density, utility frequency independence, and generator compatibility.
- ABM+ (Advanced Battery Management) implements a machine learning algorithm providing battery health status.
- Extended runtime with up to twelve Extended Battery Modules (EBMs) per UPS
- Remote on/off (ROO) and remote power off (RPO).

3 Presentation

3.1 Weights and dimensions

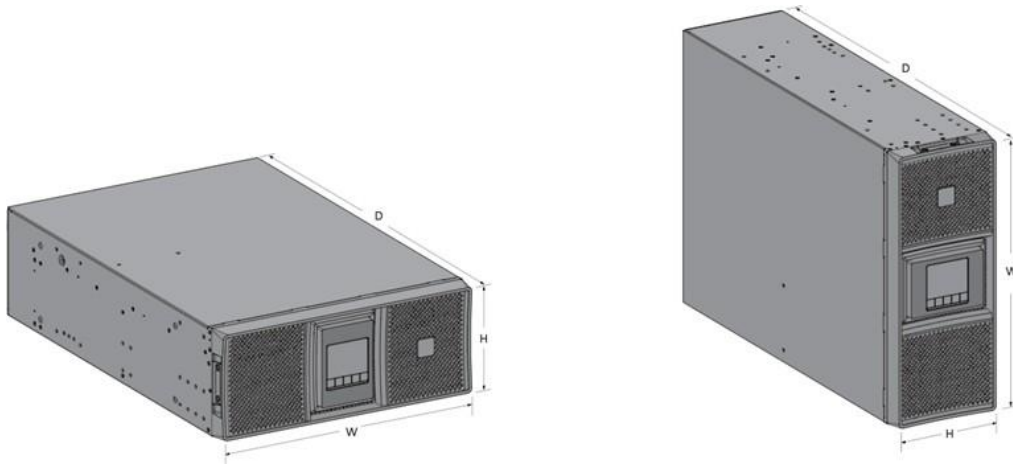

Dimensions and weight

Description (UPS)	Weights (kg / lb)	Dimensions (mm / inch) D x W x H
9PX5KIRTG2 9PX6KIRTG2	43.1 / 95	684x440x130 / 26.9x17.3x5.1
9PX8KIRTG2 9PX11KIRTG2	78.8 / 173.7	724x440x174 / 28.5x17.3x6.8
Description (EBM)	Weights (kg / lb)	Dimensions (mm / inch) D x W x H
9PXEBM180RT3UG2	65.7 / 143.8	636x440x130 / 25x17.3x5.1
9PXEBM240RT3UG2	62 / 136.7	670x440x130 / 26.4x17.3x5.1
Description (MBP)	Weights (kg / lb)	Dimensions (mm / inch) D x W x H
MBP6KIG2	2.0 / 4.4	125x177x130 / 4.9x7.0x5.1
MBP11KIG2	4.6 / 10.1	285x130x130 / 11.2x5.1x5.1

3.2 Rear panel

UPS Rear Panels

9PX5KIRTG2; 9PX6KIRTG2 (3U)

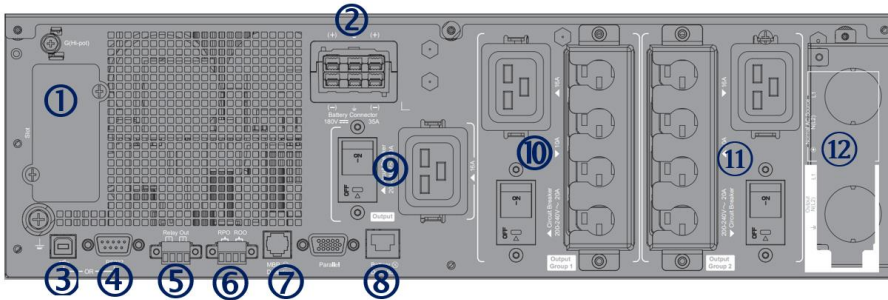

9PX8KIRTG2 ; 9PX11KIRTG2 (4U)

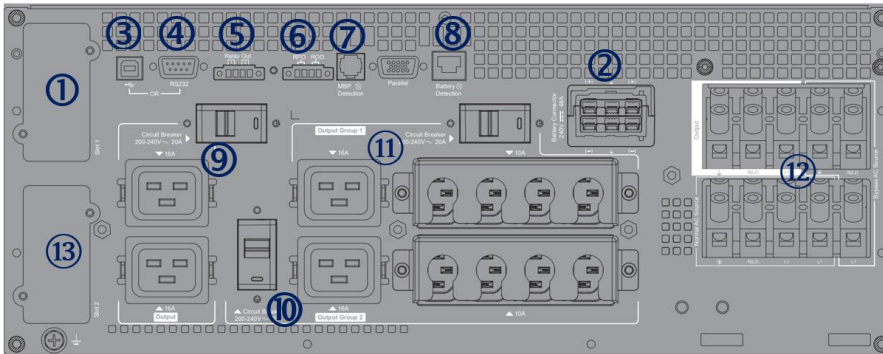

- ① Slot for communication card
- ② Battery connector
- ③ USB communication port
- ④ RS232 communication port
- ⑤ Relay output contact
- ⑥ Connectors for ROO (Remote On/Off) and RPO (Remote Power Off) control
- ⑦ Connector for HotSwap MBP detection
- ⑧ Connectors for automatic recognition of an additional battery module
- ⑨ Sockets: Primary group: outlets for connection of critical equipment:
5/6k UPS: 1xC19
8/11k UPS: 2xC19
- ⑩ Sockets Group 1:
5/6k UPS: 1xC19 + 4xC13
8/11k UPS: 1xC19 + 4xC13
- ⑪ Sockets Group 2:
5/6k UPS: 1xC19 + 4xC13
8/11k UPS: 1xC19 + 4xC13
- ⑫ Input/Output terminal blocks
- ⑬ Slot for optional communication card (8000VA and 11000VA only)

EBM Rear Panels

9PXEBM180RTG2 (3U)

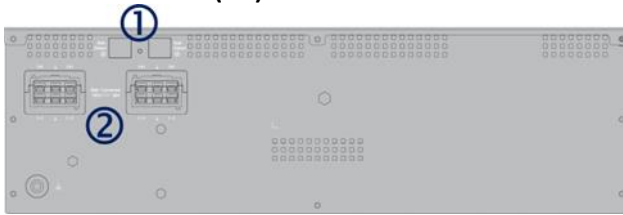

9PXEBM240RTG2 (3U)

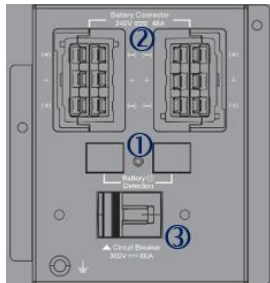

① Connectors for automatic recognition of battery modules

② Connectors for battery modules (to the UPS or to the other battery modules)

③ Circuit Breaker (240V EBM only)

MBP Rear Panels and description

The HotSwap MBP has a manual Bypass rotary switch with two positions:

- **UPS** => the load is supplied by the UPS
- **Bypass** => the load is supplied directly by the AC power source

2 lights indicate the Hotswap MBP power status:

- **"UPS supply"** green light: when active, the UPS output is available, the Bypass switch can be safely turned to UPS position
- **"Bypass mode"** red light: when active, indicates that the Hotswap MBP is on "Bypass mode" (Bypass switch turned to Bypass position)

Normal AC source switch:

Allow to safely switch off the AC source of the UPS, for UPS maintenance / replacing

MBP status detection:

A signal cable, with RJ11 connector to plug to the UPS, allows the communication to the UPS to manage the MBP status, and the indication on UPS display panel of both following status:

- MBP connection to UPS
- Bypass switch position

MBP6KiG2

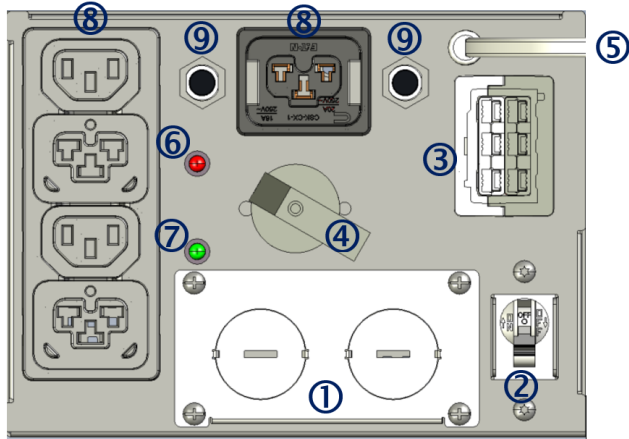

- ① Input/Output terminal blocks
- ② Normal AC source switch
- ③ Input/Output to UPS
- ④ Manual Bypass switch
- ⑤ MBP-Detection connector to the UPS
- ⑥ "Bypass" mode red light
- ⑦ UPS supply green light

MBP11KiG2



- ⑧ Sockets:
MBP6KiG2: 1 x C39 + 1 gang of 2 x C39 & 2x C13
MBP11KiG2: 4 x C39
- ⑨ Breakers

3.3 Optional accessories

Catalog Number	Description	Used With
Network-M3	Eaton Gigabit Network Card (SNMP v1/v3 and IPv4/v6 // Ethernet 10/100/1000BaseT)	All
INDGW-M2	Eaton Industrial Gateway Card (Modbus TCP / RTU)	All
Relay-MS	Eaton Relay card (1 x RS232 or 5 x Relay output)	All
INDRELAY-MS	Eaton Industrial relay card (5x relay outputs with dry contacts for remote alarm information)	All
EMPDT1H1C2	Environmental Monitoring Probe Gen2, Compatibility : Gigabit Network Card (Network-M2, Network-M3) / Industrial Gateway Card (INDGW-M2) / Eaton ePDU G3/G3+	All
9RK	Rack kit	All
BINTSYS	Battery Integration System	All
EBMCBL180RT	2m EBM cable for 180V solution	5000VA / 6000VA
EBMCBL240RT	2m EBM cable for 240V solution	8000VA / 11000VA
CBLADAPT180RT	9PX Gen1/Gen 2 EBM cable adaptor 180V 1 meter length	5000VA / 6000VA
CBLADAPT240RT	9PX Gen1/Gen 2 EBM cable adaptor 240V 1 meter length	8000VA / 11000VA
9PXEBM180RT3UG2	Eaton 9PX Extended Battery Module 180V G2	5000VA / 6000VA
9PXEBM240RT3UG2	Eaton 9PX Extended Battery Module 240V G2	8000VA / 11000VA
MBP6KIG2	Eaton HotSwap MBP 6000i G2	5000VA / 6000VA
MBP11KIG2	Eaton HotSwap MBP 11000i G2	8000VA / 11000VA

4 Installation

4.1 Inspecting the equipment

If any equipment has been damaged during shipment, keep the shipping cartons and packing materials for the carrier or place of purchase and file a claim for shipping damage. If you discover damage after acceptance, file a claim for concealed damage.

To file a claim for shipping damage or concealed damage:

1. File with the carrier within 15 days of receipt of the equipment
2. Send a copy of the damage claim within 15 days to your service representative



Check the battery recharge date on the shipping carton label. If the date has passed and the batteries were never recharged, do not use the UPS. Contact your local service representative.

UPS Package content

Verify that the following additional items are included with the UPS:

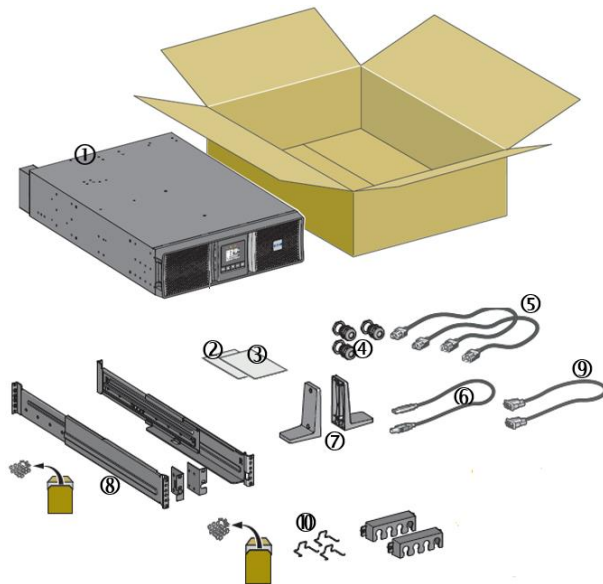

- ① UPS
- ② Quick start
- ③ Instructions and Safety Information
- ④ Cable glands (2 for 5/6K) (3 for 8/11K)
- ⑤ IEC 10A, 1,2m (2)
- ⑥ USB, 1.8m (1)
- ⑦ Stands for tower installation (2)
- ⑧ Rack kit and screws
- ⑨ RS232, 1.8m (1)
- ⑩ Cable locking system

EBM Package content

If you ordered an optional Extended Battery Module (EBM), verify that the following additional items are included with the EBM:

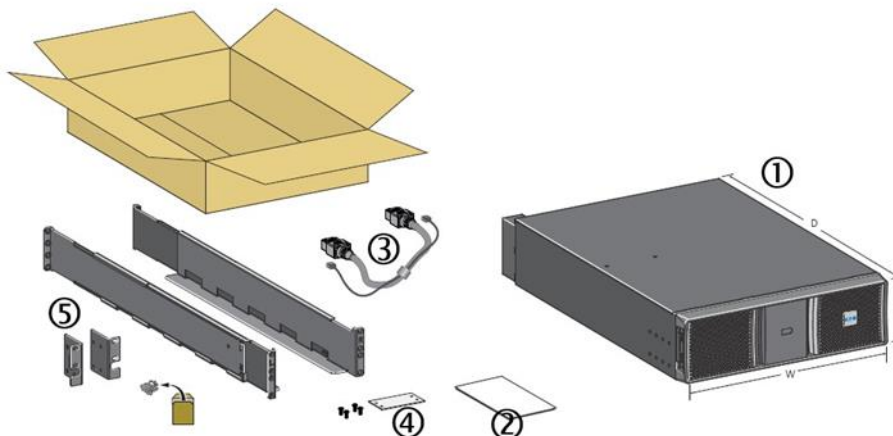

- ① EBM
- ② Quick start
- ③ Battery power cable, attached with battery detection cable
- ④ Stabilizer bracket (4 screws included)
- ⑤ Rack kit and screws

MBP package content

If you ordered an optional Maintenance ByPass (MBP), verify that the following additional items are included with the MBP:

MBP6KiG2

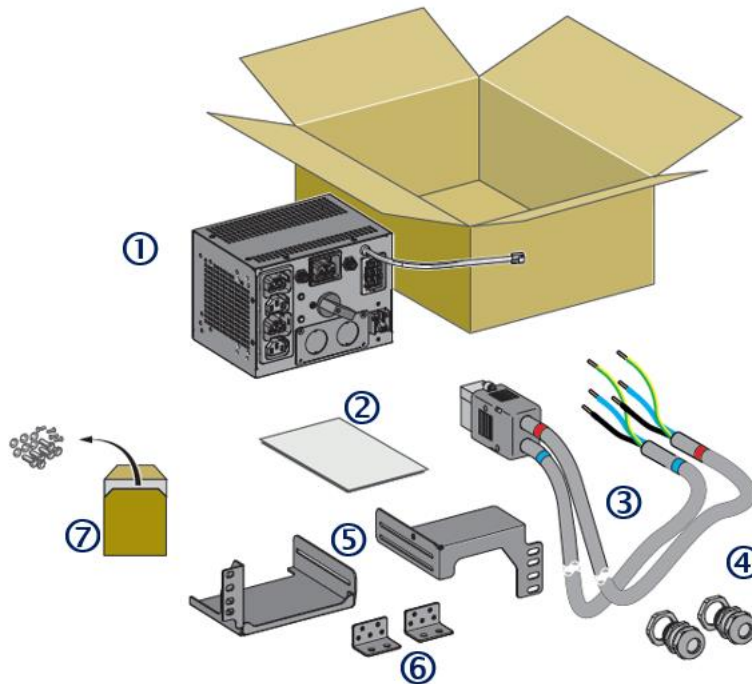

- ① MBP
- ② Quick start
- ③ MBP Cord set (Only for 6k MBP)
- ④ Cable glands
- ⑤ Ears for rack mounting
- ⑥ MBP fixation ears
- ⑦ Kraft envelop with screws

MBP11KiG2

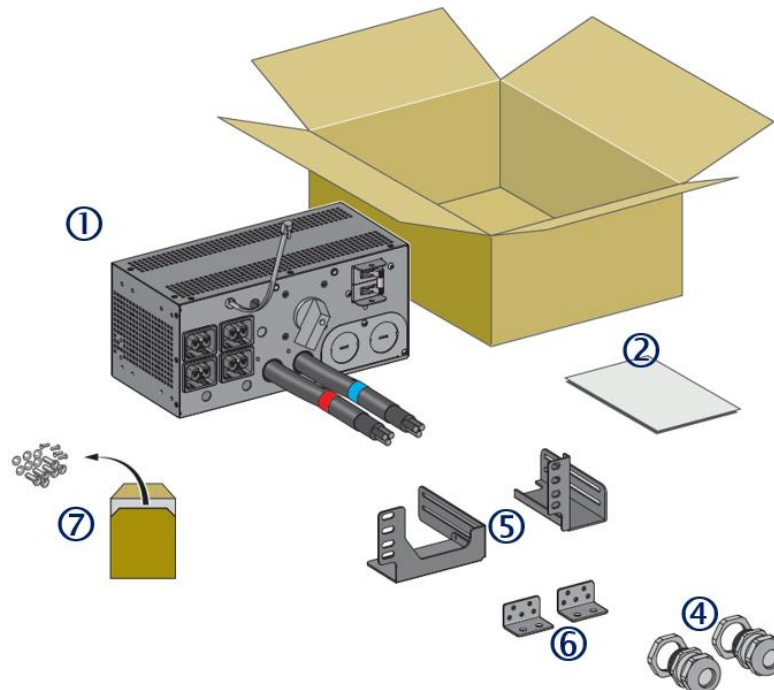

4.2 Unpacking the UPS

Unpacking without removing the batteries

The UPS is wrapped in a paper tray lifting system. It is prevented from slipping by the cardboard (blue circles) pasted on the paper tray. The UPS can be lifted by two people using the 2 "handles" per side (red circles).

Take care to carry the product horizontally.



The UPS is heavy, wear appropriate safety equipment.

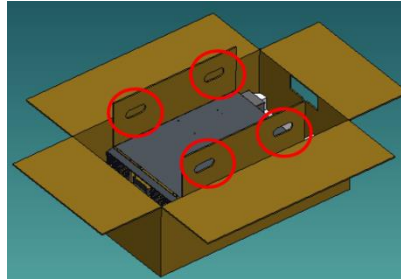
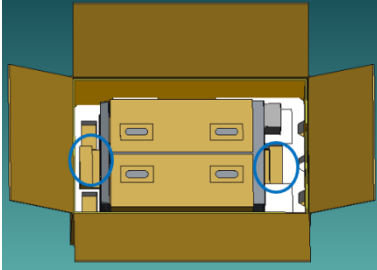

Removing the batteries before unpacking

The carton box is designed to give access to front panel without removing the UPS from the carton. Follow the steps below to get access to front panel and to remove the battery packs.

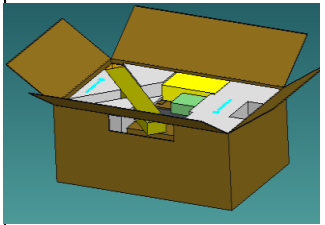
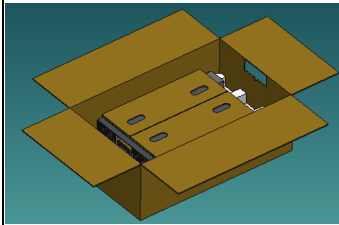
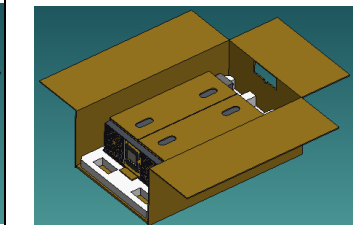
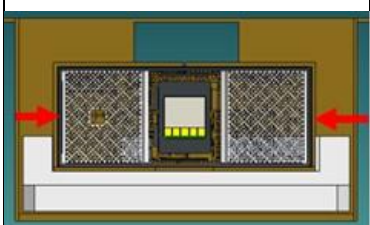
1) Open the carton box	2) Remove the rail kit and foam top of the product	3) Remove the cardboard board inside the carton, use knife to remove the carton cover front of the product	4) Remove the front panel and battery pack in the product.
			

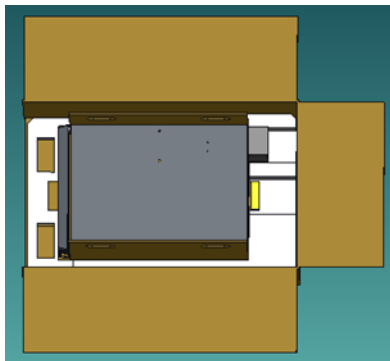

After having removed the battery pack, the product frame could be handled out by one person:

4.3 Recommended positions

Installation in tower position



If you ordered other UPS accessories, refer to specific user manuals to check the tower installation with the UPS. To install the UPS:

- Place the UPS on a flat, stable surface in its final location.
- Always keep 6" or 150 mm of free space behind the UPS rear panel 6" or for ventilation.
- If installing additional cabinets, place them next to the UPS in their final location.

Before installing the UPS in tower position, you can rotate the LCD. Follow steps to adjust the orientation of the LCD panel and of the logo.



Installation in rack position

Follow steps bellow for module mounting on the rails.



The rails and necessary hardware are supplied by Eaton



As UPS is heavy, the batteries can be removed before mounting the UPS on the rack. Refer to "Installation in rack position with batteries removed".

UPS installation in rack position without removing the battery

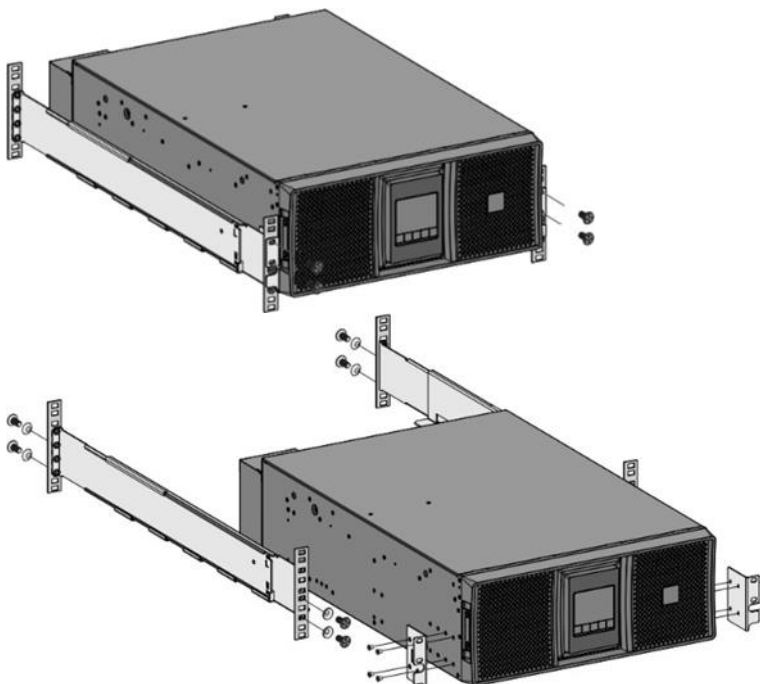

- ① Screw the rail on the back of the rack.
- ② Screw the rail on the front of the rack using the two holes at the bottom.
- ③ Screw the ears plate to the UPS.
- ④ Place the UPS on the rails and screw the ears plate to the top hole of the rail.

5000VA and 6000VA UPS: Installation in rack position by removing the battery

Follow steps 1 to 16.

Steps 1 to 6: Remove the battery

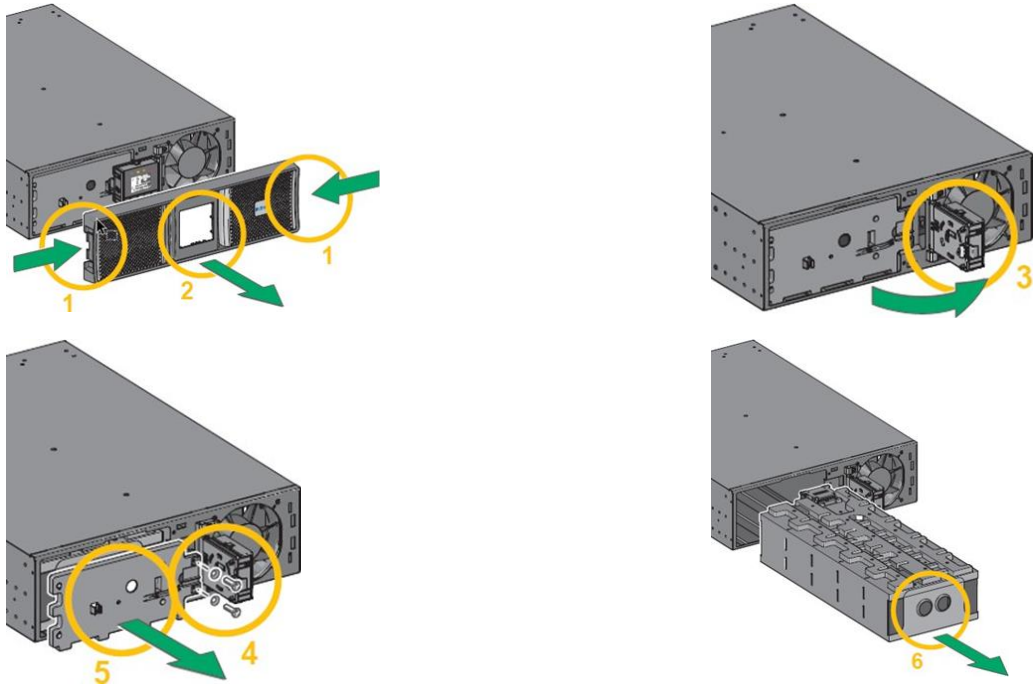

Steps 7 to 10: Install the Rack Kit and Fix the UPS cabinet (w/o battery)

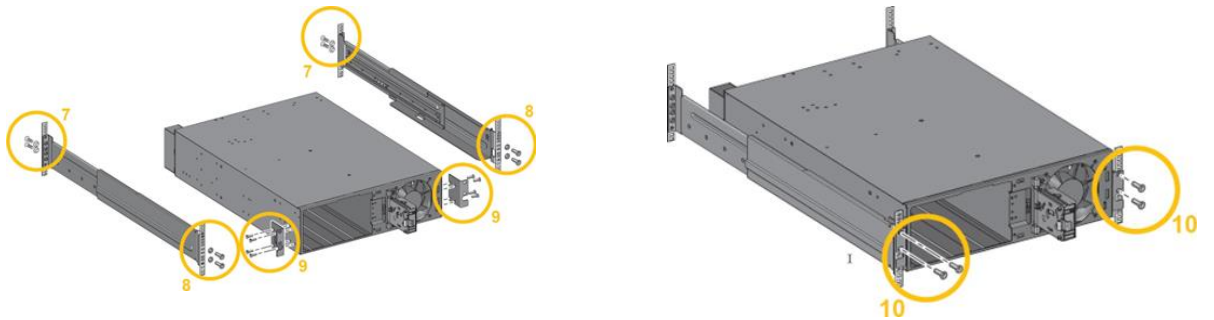

Steps 11 to 16: Replace the battery and the front panel

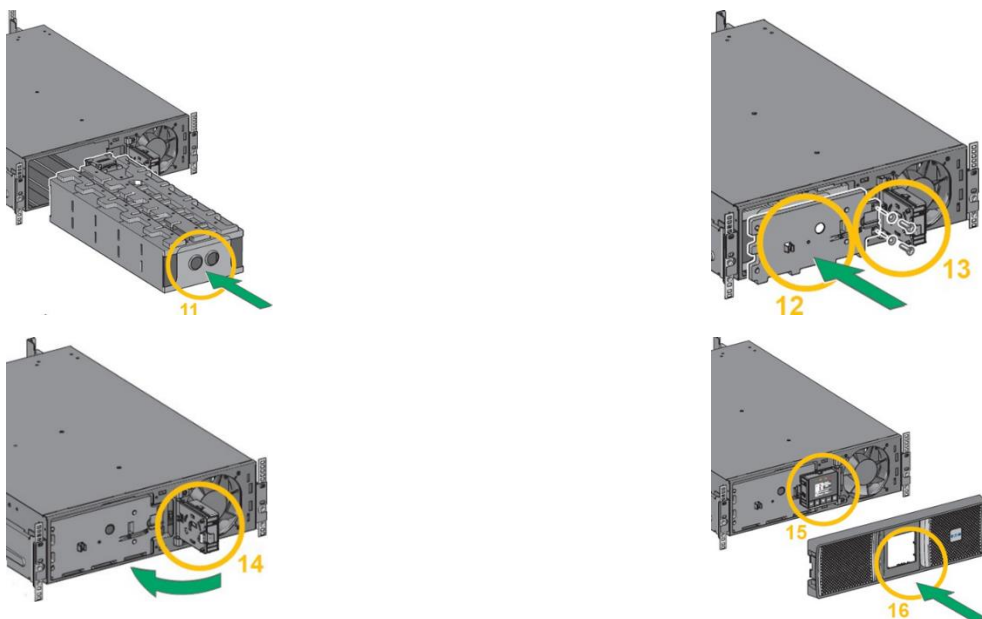

8000VA and 11000VA UPS: Installation in rack position by removing the battery

Follow steps 1 to 16.

Steps 1 to 7: Remove the battery

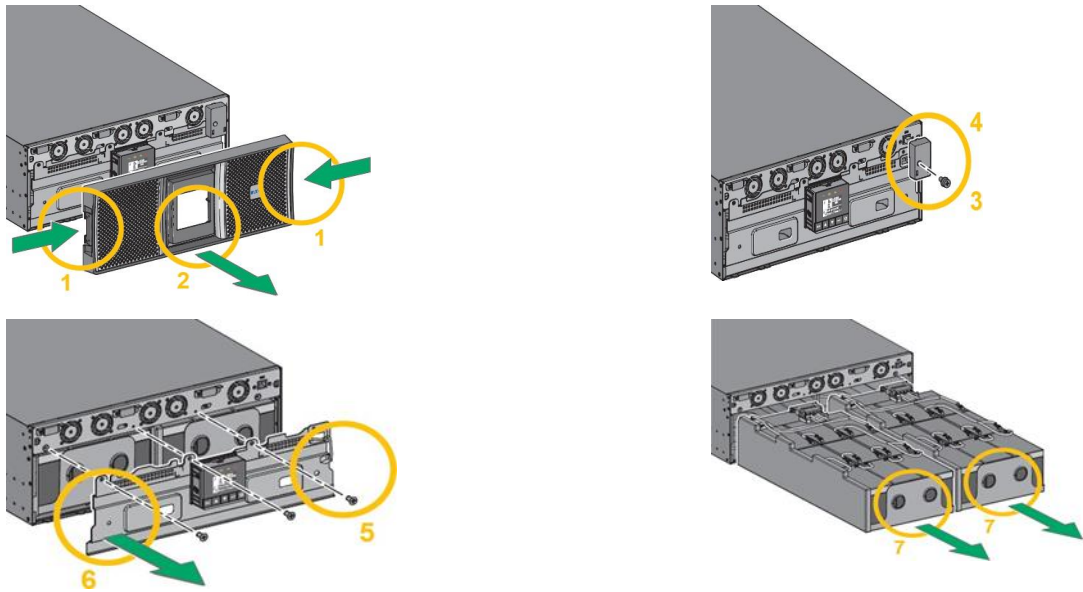

Steps 8 to 11: Install the Rack Kit and Fix the UPS cabinet (w/o battery)

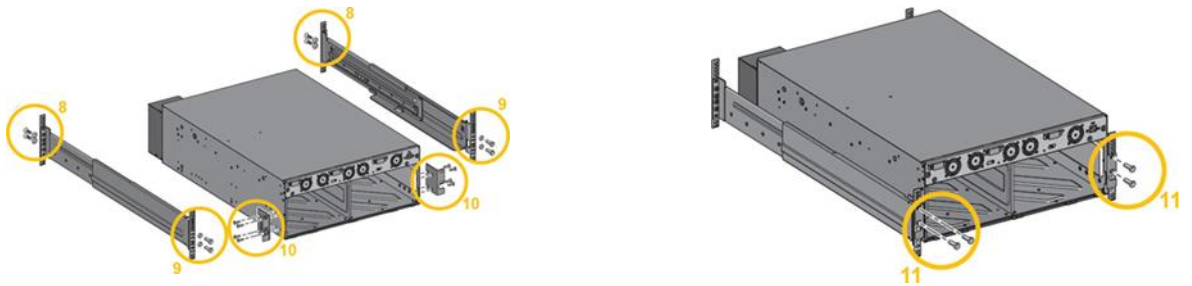

Steps 12 to 18: Replace the battery and the front panel

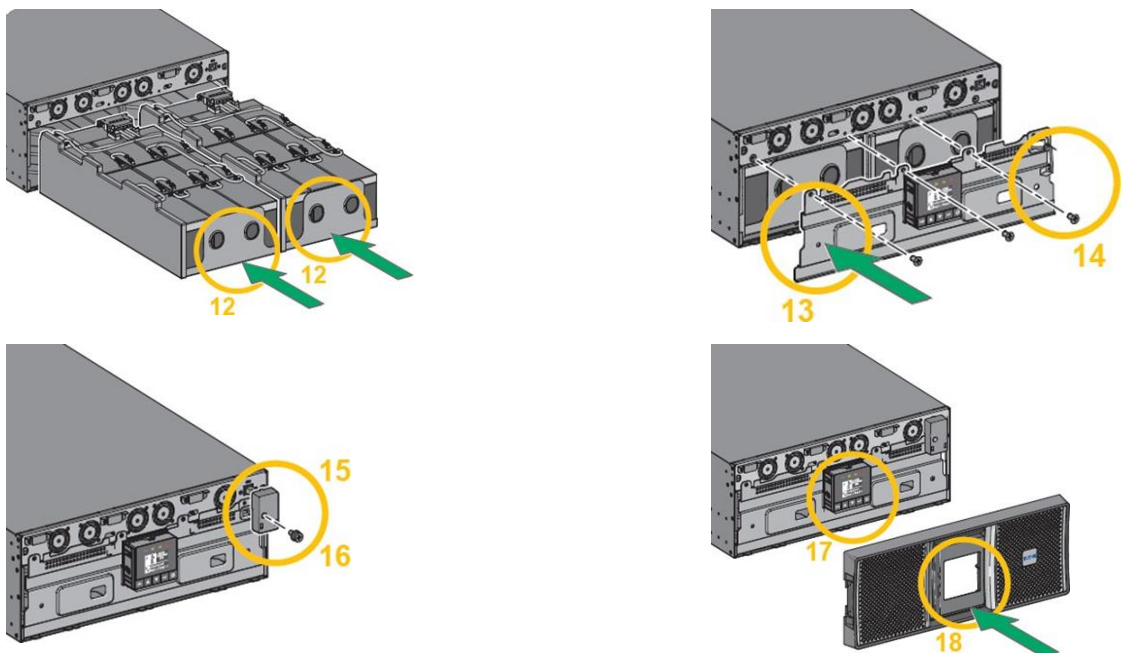

4.4 EBM connection



Extended runtime with up to twelve Extended Battery Modules (EBMs) per UPS



When 11KVA UPS is used with more than 8 EBMs (between 8 and 12), additional ground PE wires (Min 10AWG or 10mm² cross-sectional area identical to input) are required, see illustration below:

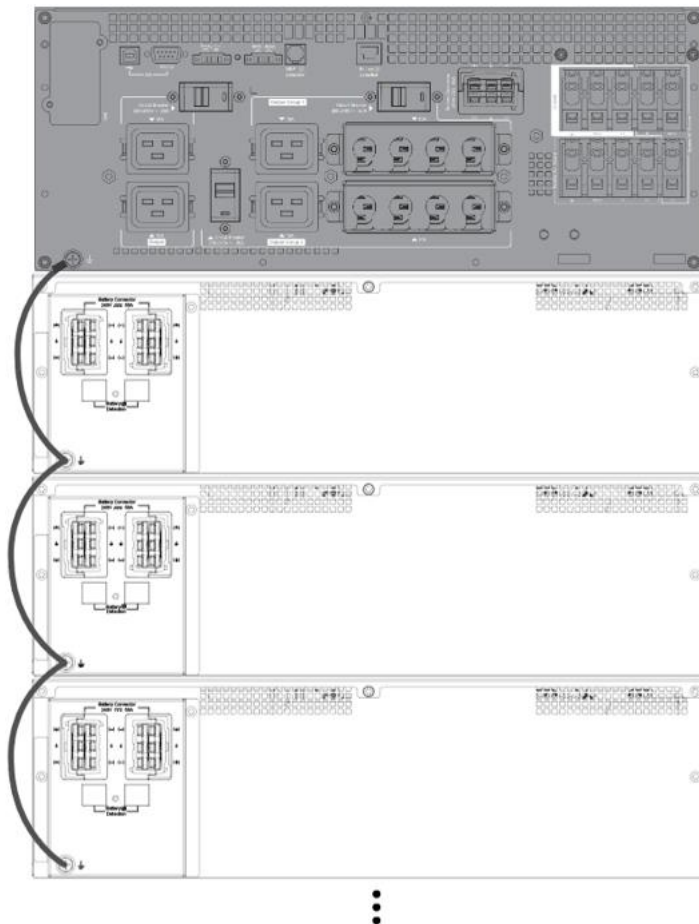

Tour installation

 A small amount of arcing may occur when connecting an EBM to the UPS. This is normal and will not harm personnel. Insert the EBM cable into the UPS battery connector quickly and firmly.

1. Attach the UPS and the EBMs to each other using the supplied mounting plate.
2. Connect the EBMs power cable and the attached battery detection cable as shown in the picture.
3. Verify that the EBM connections are tight and that adequate bend radius and strain relief exist for each cable
4. Switch On the EBM breaker (for 240V PX EBM only)

180V EBM for 5000VA and 6000VA UPS

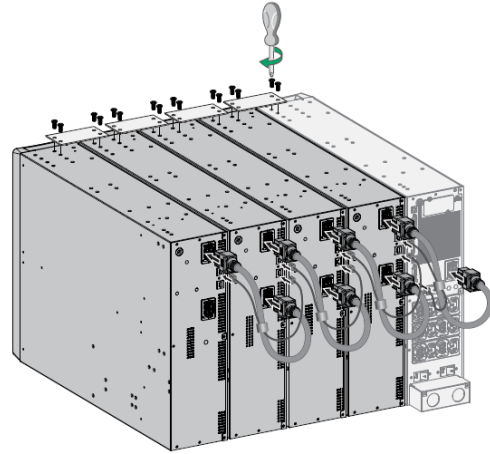
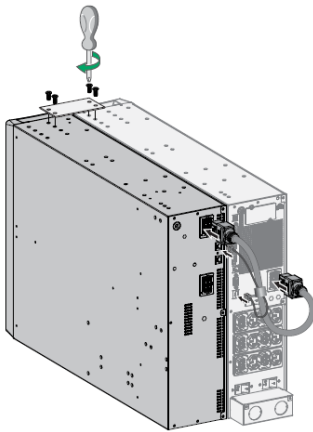

240V EBM for 8000VA and 11000VA UPS

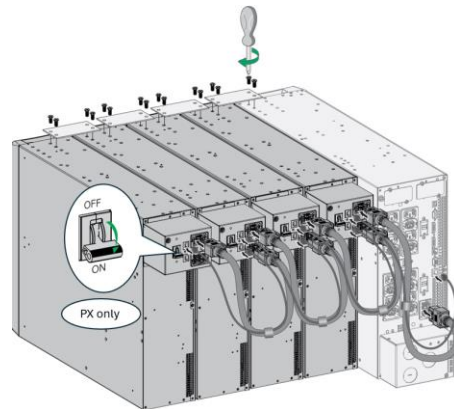
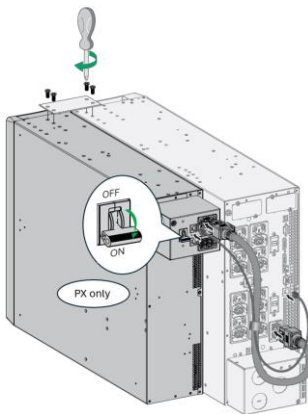

Rack installation



A small amount of arcing may occur when connecting an EBM to the UPS. This is normal and will not harm personnel. Insert the EBM cable into the UPS battery connector quickly and firmly.



To increase stability, it is preferable to place the EBM below the UPS.

1. Attach the UPS and the EBMs to each other using the supplied mounting plate.
2. Connect the EBMs power cable and the attached battery detection cable as shown in the picture.
3. Verify that the EBM connections are tight and that adequate bend radius and strain relief exist for each cable.
4. Switch On the EBM breaker (for 240V PX EBM only)

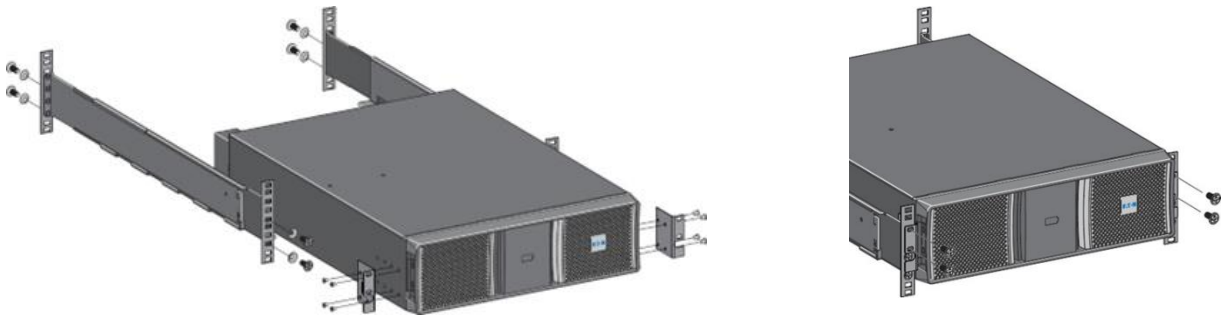

180V EBM for 5000VA and 6000VA UPS

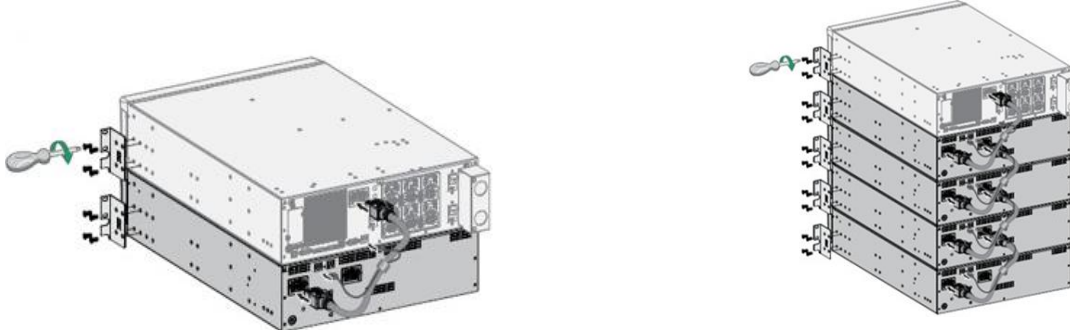

240V EBM for 8000VA and 11000VA UPS

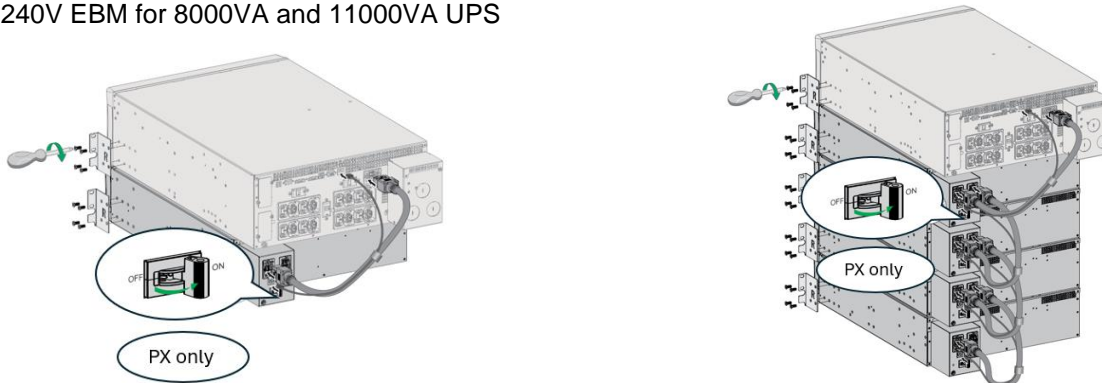

4.5 UPS connection

Hardwired connection

UPS connection without HotSwap MBP module

 Check that the indications on the name plate located on the back of the UPS correspond to the AC-power source and the true electrical consumption of the total load.

 Caution: switch off utility power to the distribution point where the UPS will be connected. Be absolutely sure there is no power.

Unscrew the I/O box

5000VA and 6000VA

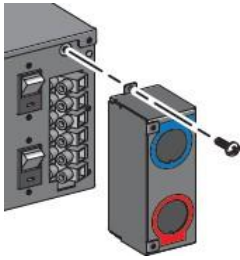

8000VA and 11000VA

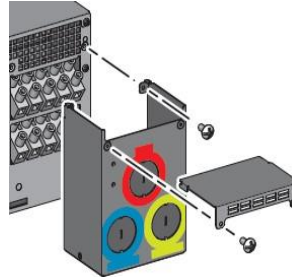

Remove the blue circular cover (Input) and screw the cable gland.

5000VA and 6000VA

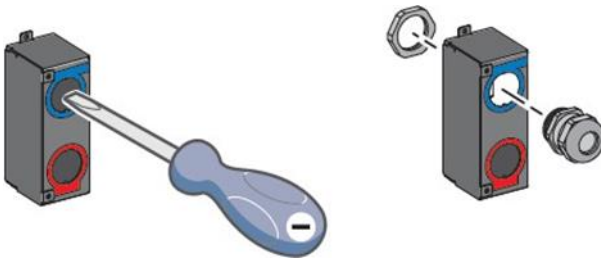

8000VA and 11000VA

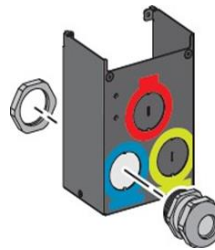

Strip the copper supply cable keeping the Earth cable longer for safety purpose

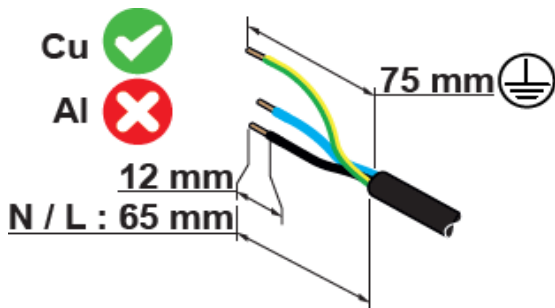

Insert the supply cable in the I/O box

5000VA and 6000VA

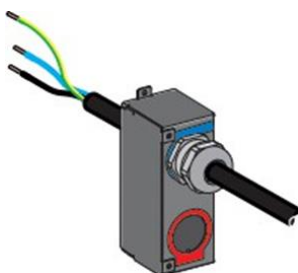

8000VA and 11000VA

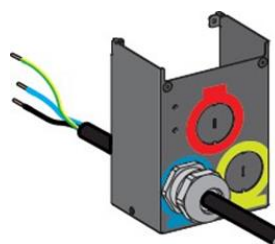

⚠ High leakage current: Earth connection essential before connecting supply

Recommended protective devices and cable cross-sections

3000VA, 5000VA and 6000VA

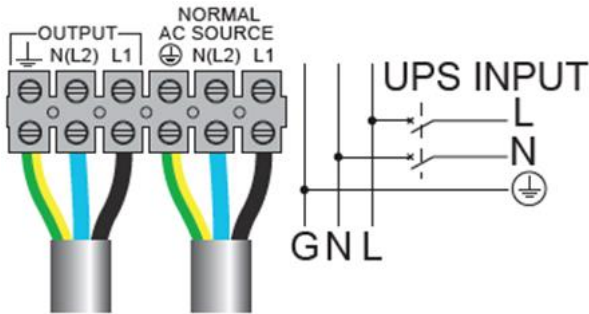

8000VA and 11000VA

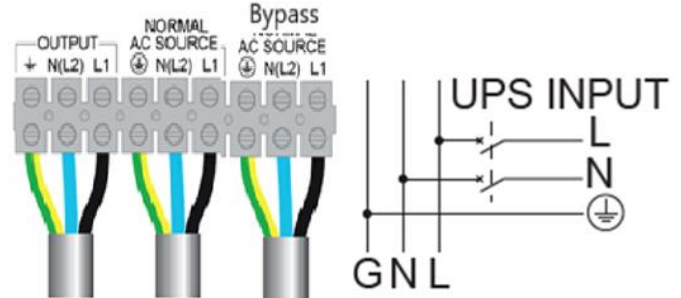

⚠ CAUTION, for 8000VA and 11000VA: there is a risk of voltage backfeed. Before working on this circuit, isolate the UPS, then check for Hazardous Voltage between all terminals including the protective earth. A suitable 2 poles AC contactor at the UPS input may be implemented as an external backfeed protection.

Recommended upstream protection

⚠ The upstream circuit breaker for Normal AC/Bypass AC must be easily accessible. The unit can be disconnected from AC power source by opening this circuit breaker.

UPS power rating	Upstream circuit breaker (CB)
5000VA	D curve 2 poles – 32A
6000VA	D curve 2 poles – 40A
8000VA	D curve 2 poles – 50A
11000VA (Standard installation*)	D curve 2 poles – 63A*
11000VA (Advanced installation)	D curve 2 poles – 80A

* If the UPS load is less than 90%; Or the total battery Ah less than 20Ah, the UPS will limit the charger current to 4A ($0.2 \times 20 = 4A$), in this case, you could select the 70A (in US/CSA) / 63A(others) upstream circuit breaker. (these conditions are not certificated)

Do not use 30 mA RCD/ELCB breaker upstream the UPS.

Recommended cable cross-sections for standard installation

UPS power rating	Maximum wire size	Minimum input wire size			Minimum output wire size			Min Tightening torque
		L1	N(L2)	⊕	L1	N(L2)	⊕	
5kVA	6 AWG / 16mm ²	10AWG / 6mm ²			10AWG / 6mm ²			10.6 lb-in
6kVA		8AWG / 10mm ²			8AWG / 6mm ²			
8kVA	4 AWG / 25 mm ²	6AWG / 10mm ²			8AWG / 10mm ²			22 lb-in
11kVA		4AWG / 10mm ²			6AWG / 10mm ²			

NOTE For Supply connections, use wires suitable for at least 90°C copper or equivalent AWG used in US/CSA, mm² used in other countries.

⚠ High leakage current, an additional connection point is available. The minimum cross-section of additional PE conductor shall be at least equal to Input wires.

Screw the electric cables, starting by the earth wire



Screw the I/O box and tighten the cable gland

5000VA and 6000VA

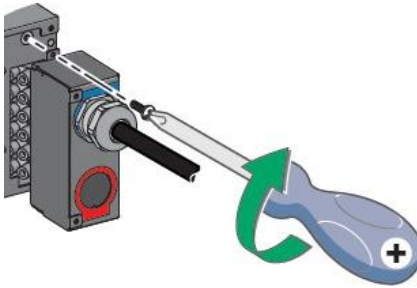

8000VA and 11000VA

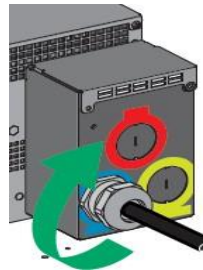
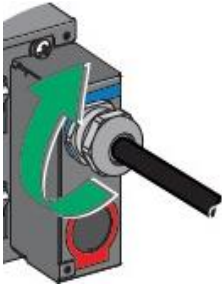
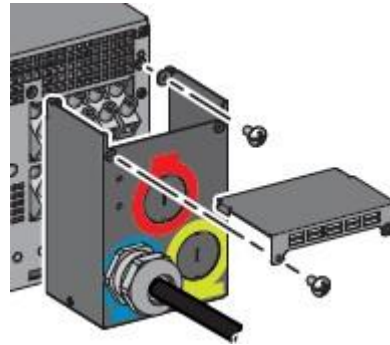

Connect the output cables, switch on the breaker and start the UPS

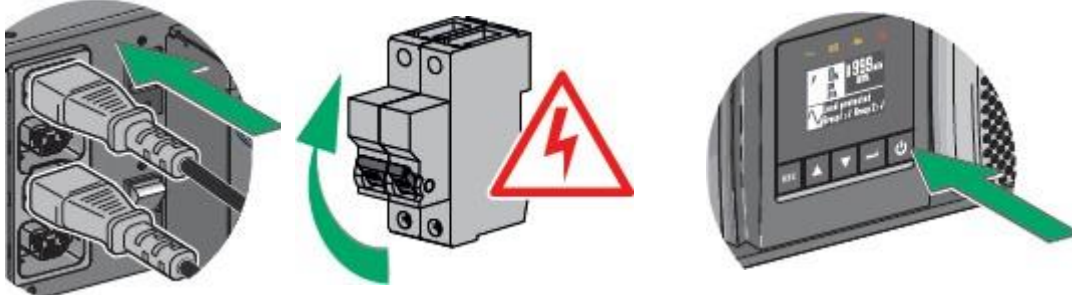

Installation depending on the system earthing arrangement (SEA)

For 5000VA and 6000VA

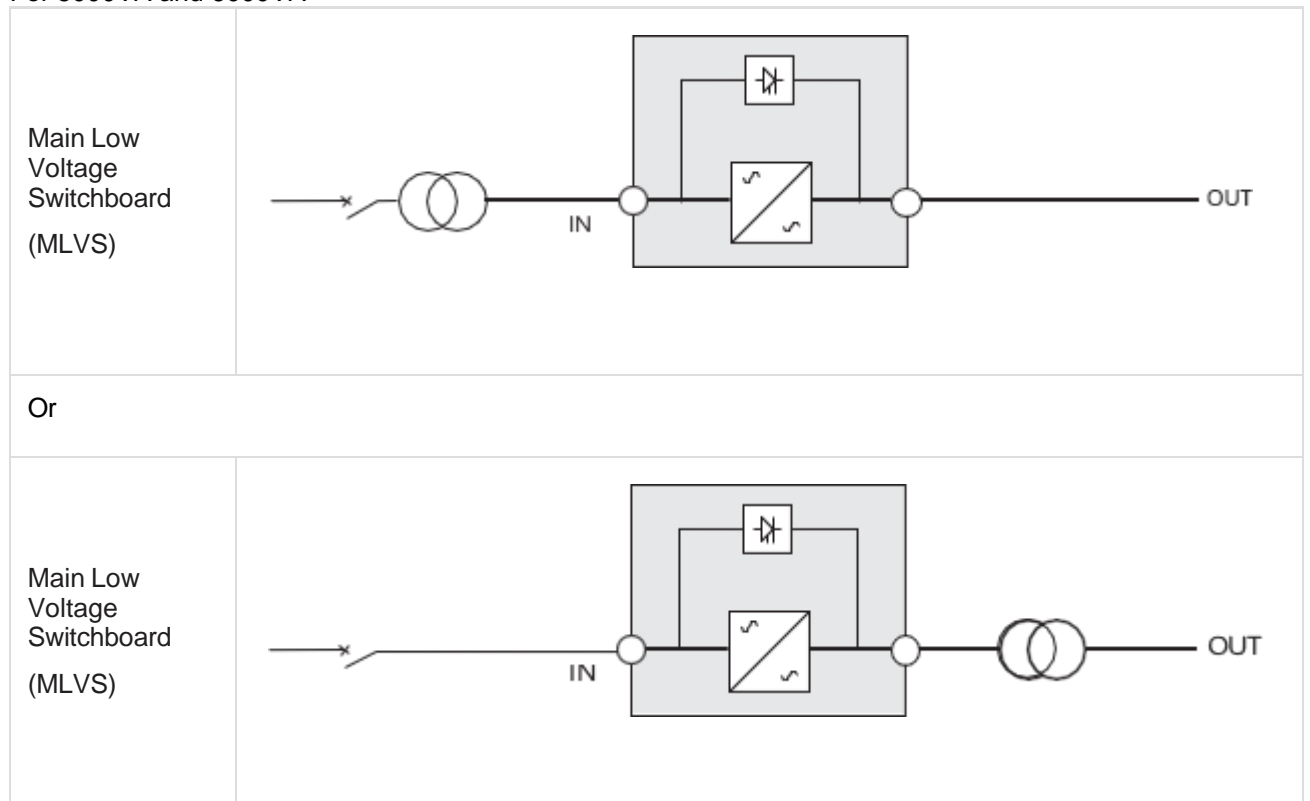

Because 8000VA and 11000VA have multiple sources of supply, below figure for 8000VA and 11000VA:

• **UPS with common Normal and Bypass AC inputs**

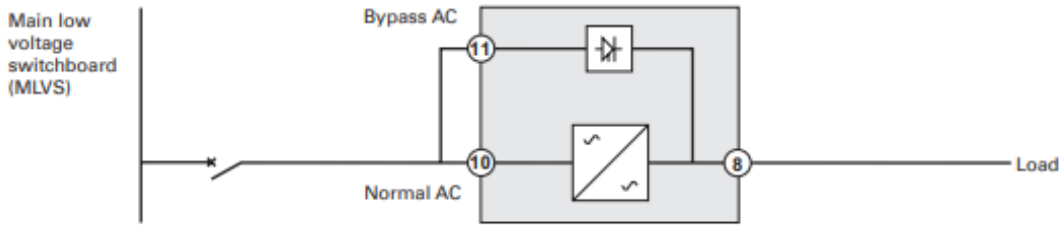

Change in SEA between upstream and downstream or galvanic isolation required

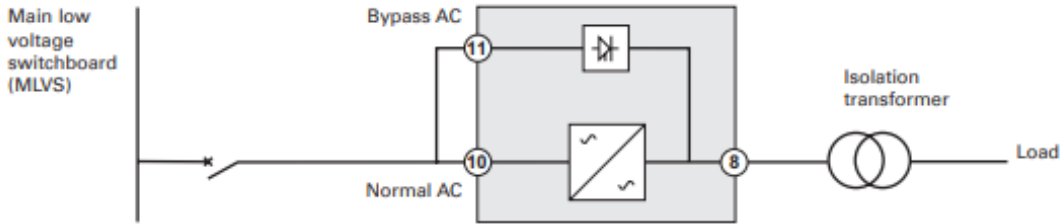

• **UPS with separate Normal and Bypass AC inputs**

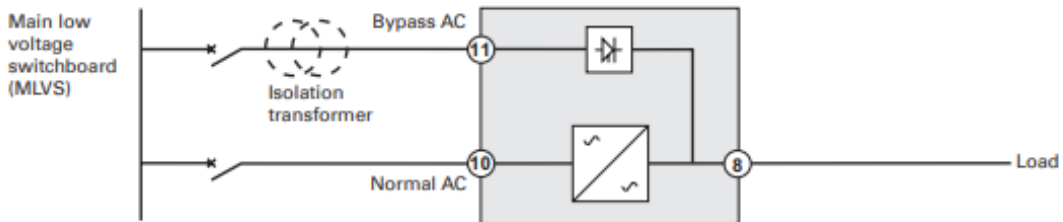

Change in SEA between upstream and downstream or galvanic isolation required

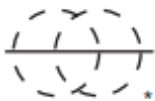
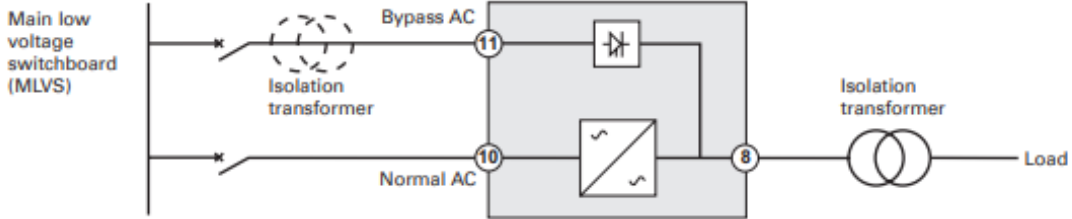

The transformer is not necessary if:

- Normal and Bypass inputs are connected to the same source,
- and wires cross-sections and lengths of Normal and Bypass inputs are identical,
- and upstream protection is provided by only one switch with RCD (Residual Current Device) for Normal and Bypass AC inputs.

- **UPS with separate Normal and Bypass AC inputs, supplied by separate sources**

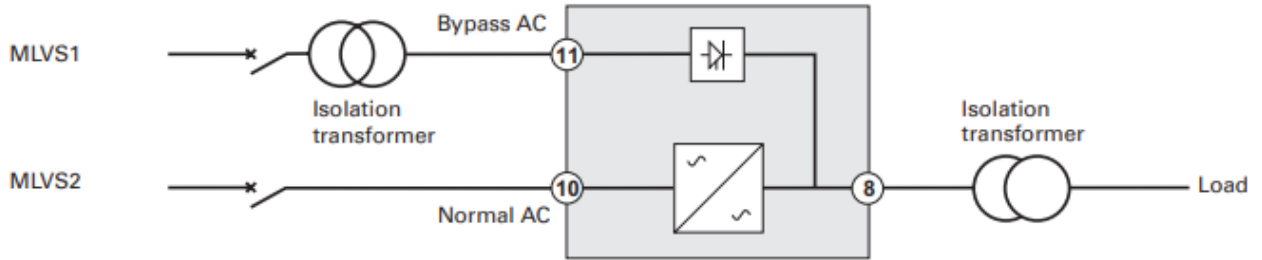
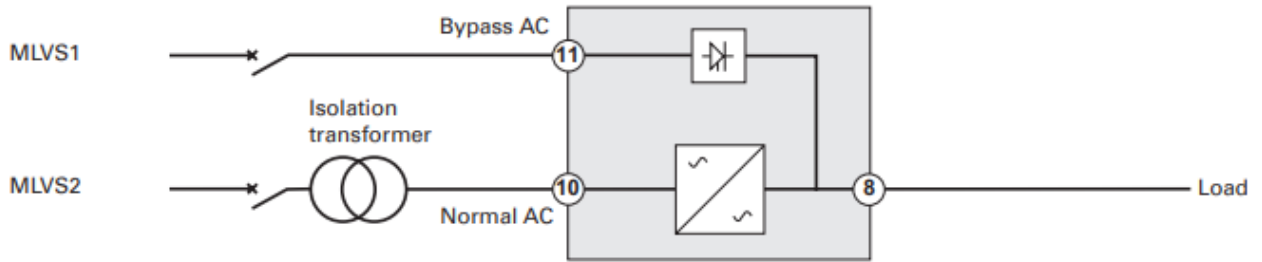

Change in SEA between upstream and downstream or galvanic isolation required

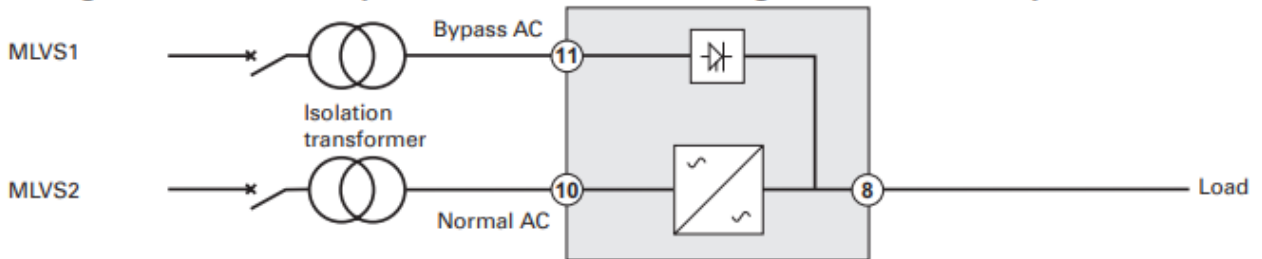

- **Hot standby**

Configuration used to provide N+1 redundancy to critical loads.

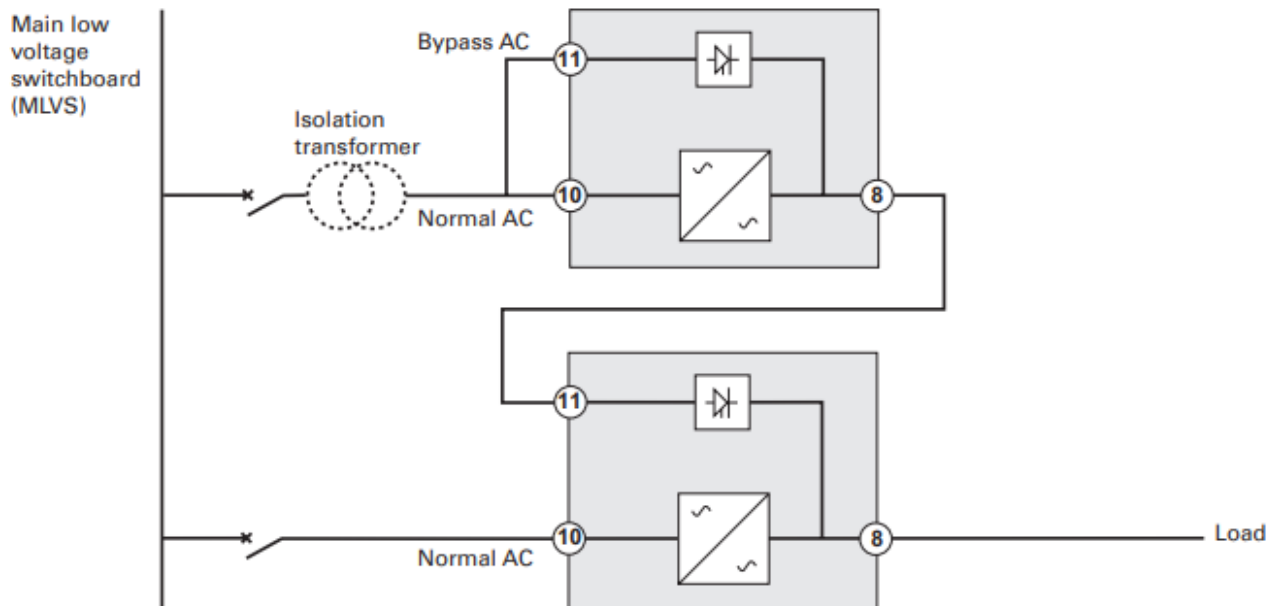

4.6 Register warranty

Register warranty at <https://www.pqproductregistration.eaton.com>

4.7 Connection with MBP

The Eaton® HotSwap MBP module makes it possible to service or even replace the UPS without affecting the connected loads (HotSwap function).

You can safely eliminate the effects of UPS maintenance and guard the integrity of your equipment.

Providing outstanding reliability, the Eaton HotSwap MBP unique benefits include:

- Easy and fast connection to UPS due to Input/Output and signal "all in one" patented connector (Hotswap MBP 5/6kVA range)
- "make before break" feature to allow full servicing (electrical power continuity) when switching from UPS position to Bypass (and vice versa)
- Communication feature with UPS*: detection of MBP connection and switch position (Normal or Bypass) (* works only with some approved EATON UPS - contact your Eaton reseller for more information)
- Load connection by both terminal blocks and IEC outlets
- Adjustable 19" Rack kit and multiple positions Tower installation kit provided
- Backed by worldwide agency approvals.



In the configuration "UPS + EBM", the MBP must be mounted at the back of EBM.

Mechanical installation in rack position

For the MBP used with 8000VA and 11000VA UPS, depending on the configuration, there are two different assemblies, identified with letters **A** (UPS only) and **B** (UPS+EBM)
Final assembly position:

MBP6KiG2 used with 5000VA and 6000VA UPS

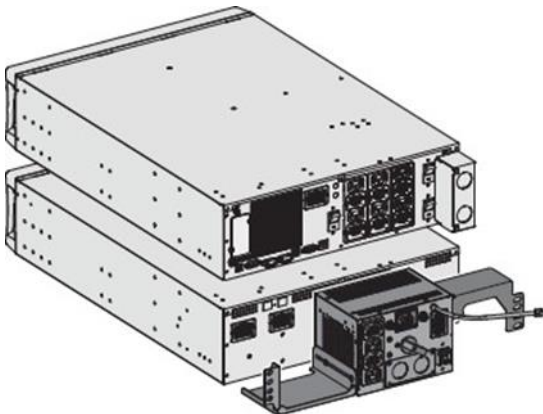
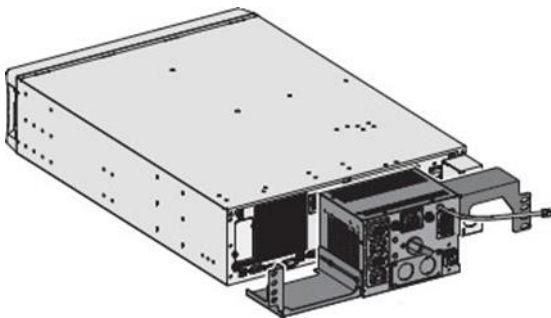

MBP11KiG2 used with 8000VA and 11000VA UPS

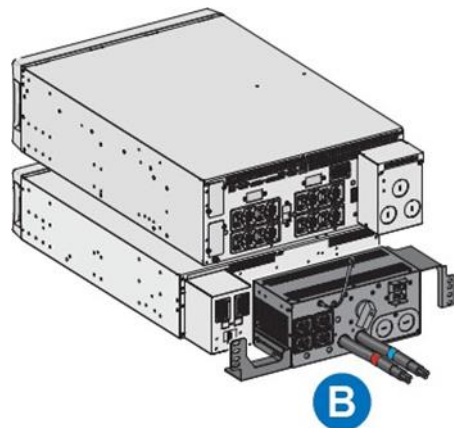
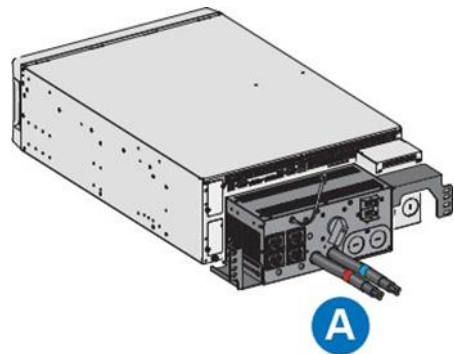

Follow the steps below to install the MBP in rack position.

1. Screw the ears on each MBP side.

MBP6KiG2 used with 5000VA and 6000VA UPS

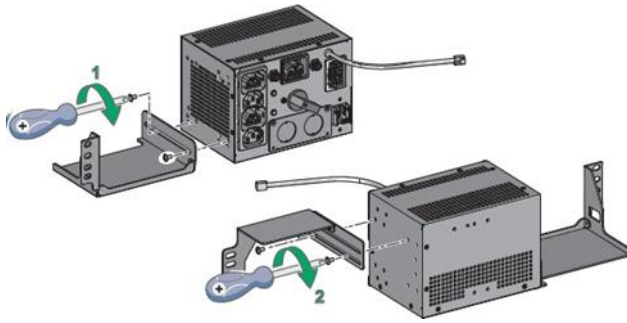

MBP11KiG2 used with 8000VA and 11000VA UPS

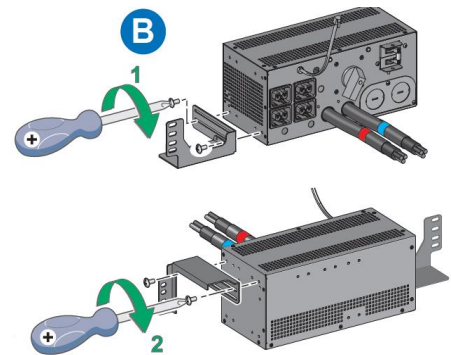
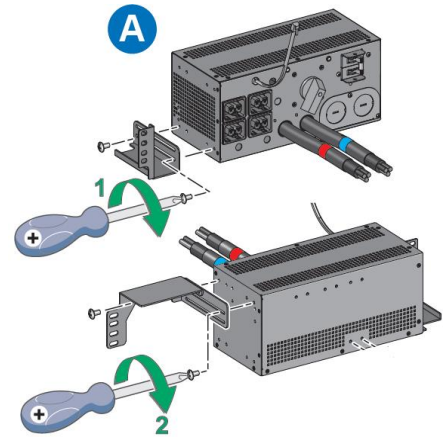

2. Mount the MBP with its ears on the UPS rack.

MBP6KiG2 used with 5000VA and 6000VA UPS

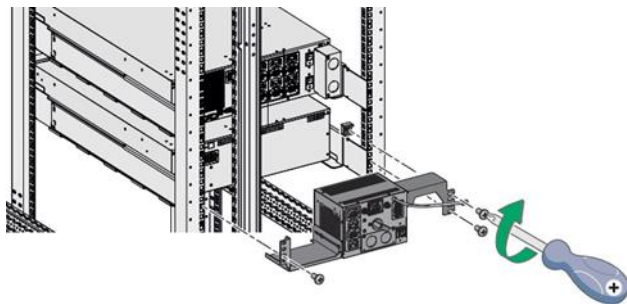

MBP11KiG2 used with 8000VA and 11000VA UPS

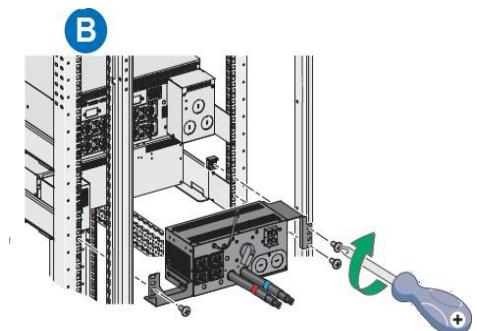
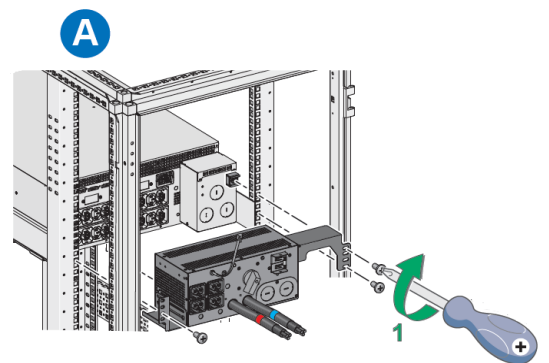

Mechanical installation in tower position

Depending on the configuration, there are four different assemblies, identified with letters A, B, C and D.

The different ways to mount the MBP with the UPS or the "UPS+EBM" are identified by the A, B, C & D letters.

Final assembly position:

MBP6KiG2 used with 5000VA and 6000VA UPS

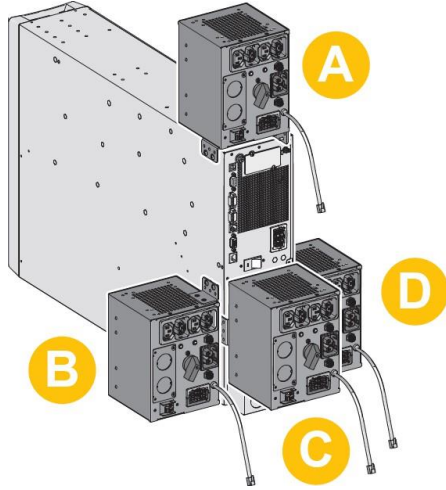

MBP11KiG2 used with 8000VA and 11000VA UPS

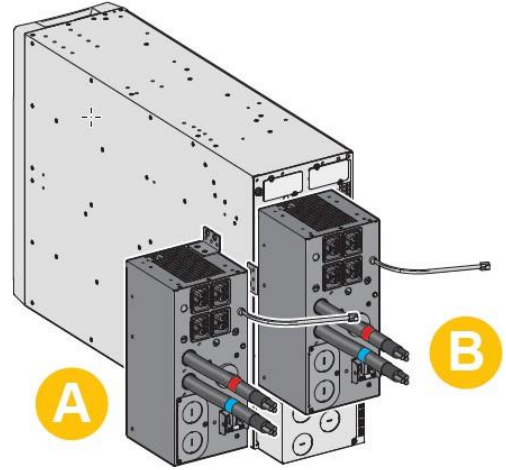

MBP6KiG2 used with 5000VA and 6000VA UPS + 180V EBM

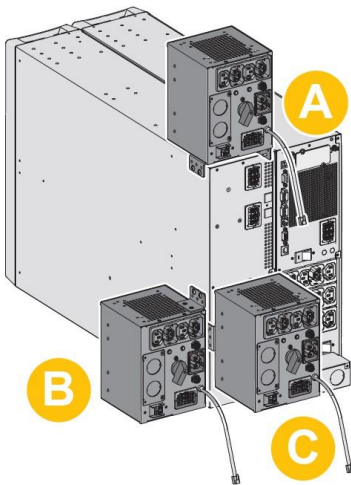

MBP11KiG2 used with 8000VA and 11000VA UPS + 240V EBM

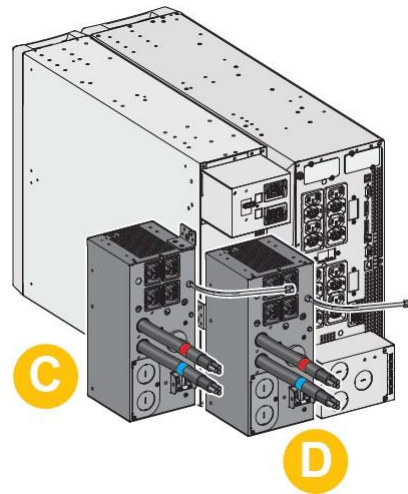

Follow the steps below to install the MBP in tower position.

Screw the ears on each MBP side.

MBP6KiG2 used with 5000VA and 6000VA UPS

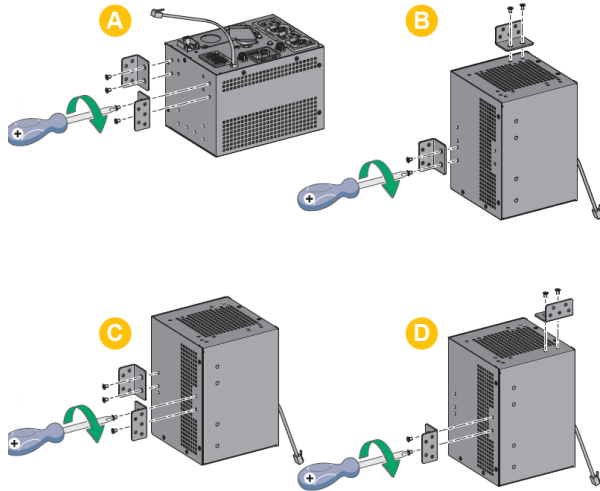

MBP11KiG2 used with 8000VA and 11000VA UPS

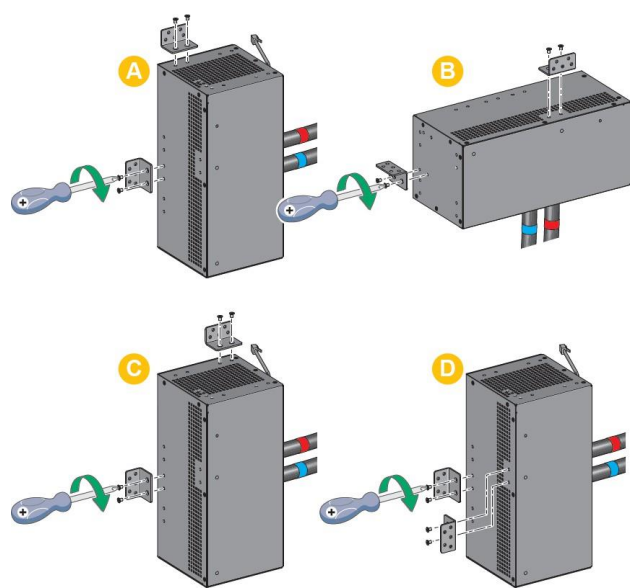

Mount the MBP with its ears on the UPS or EBM

MBP6KiG2 used with 5000VA and 6000VA UPS

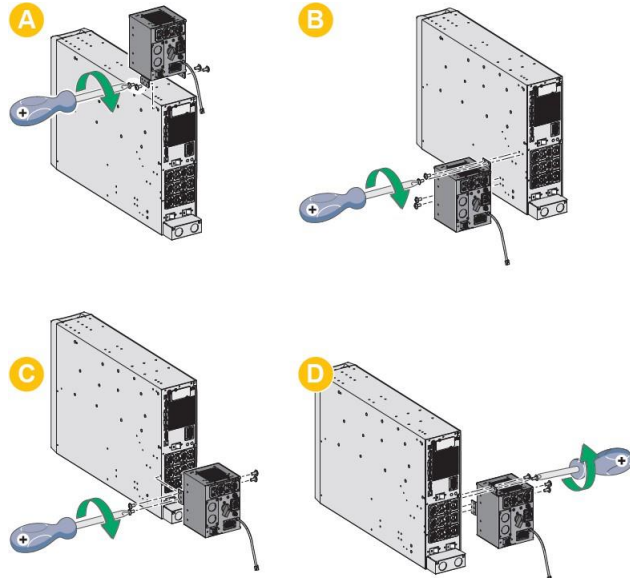

MBP11KiG2 used with 8000VA and 11000VA UPS

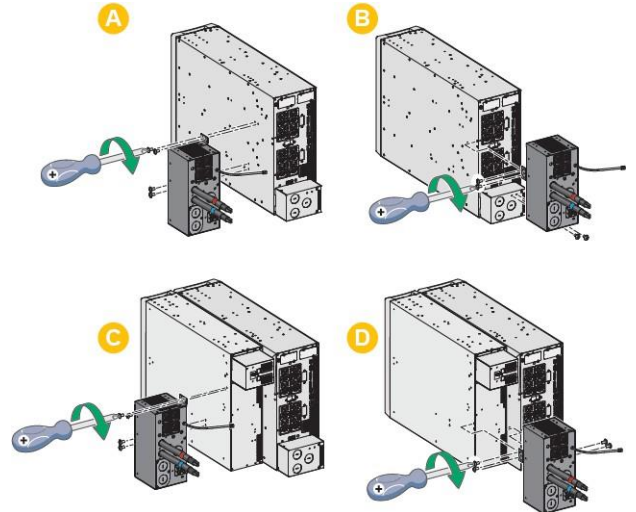

MBP electrical connection



Caution: Manually trip the input circuit breaker of your installation before connecting the supply cables.

Access to the terminal block, remove the circular covers and screw the cable glands.

MBP6KiG2 used with 5000VA and 6000VA UPS

MBP11KiG2 used with 8000VA and 11000VA UPS

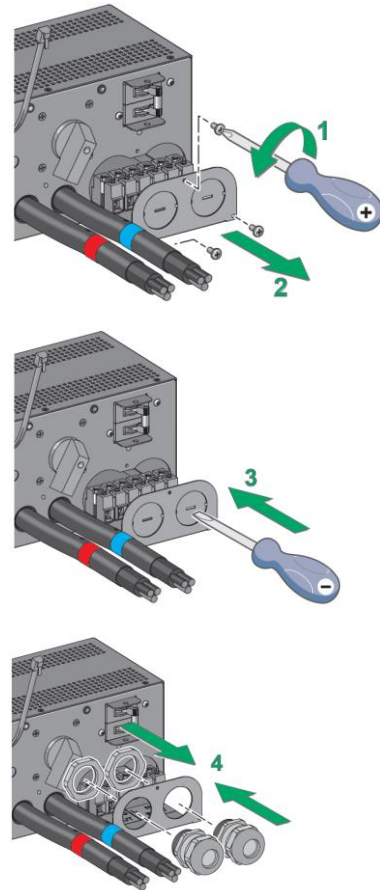

Insert the electrical cables.

 Follow below instructions for upstream protection and cable cross section.

 Use copper cable only, and not aluminum.

Recommended cable cross-sections

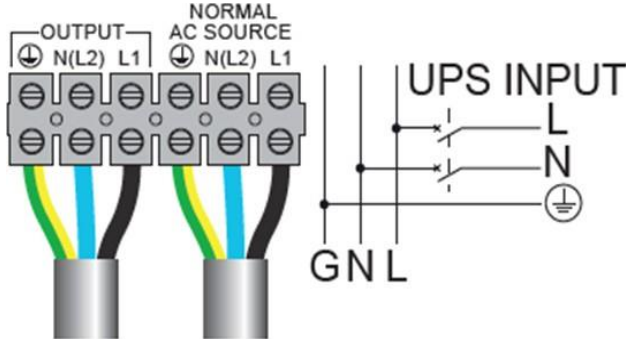

Recommended upstream protection

MBP used with	Upstream circuit breaker (CB)
5000VA and 6000VA UPS	D curve 2 poles – 32A
8000VA UPS	D curve 2 poles – 50A
11000VA UPS	D curve 2 poles – 63A

Recommended cable cross-sections for standard installation

Terminal position	Wire function	Terminal wire size rating	Minimum input wire size		Tightening torque
L1	Phase	4-16 mm ² (12-6 AWG)	5000VA 6000VA	6 mm ² (10 AWG) copper	6.9 lb in / 0.78 Nm
N(L2)	Neutral (Phase)		8000VA 11000VA		
	Protective Earth (PE)				

 Strip the copper supply cable keeping the Earth cable longer for safety purpose.

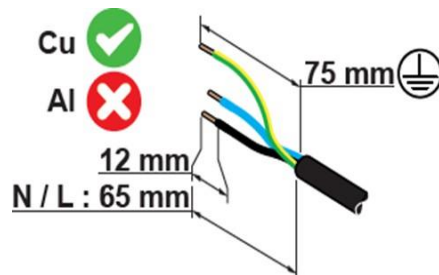

MBP6KiG2 used with 5000VA and 6000VA UPS

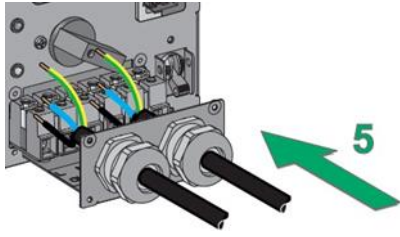

MBP11KiG2 used with 8000VA and 11000VA UPS

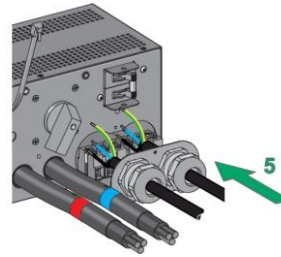

Tighten well the cable glands

MBP6KiG2 used with 5000VA and 6000VA UPS

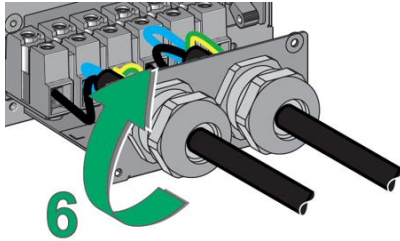

MBP11KiG2 used with 8000VA and 11000VA UPS

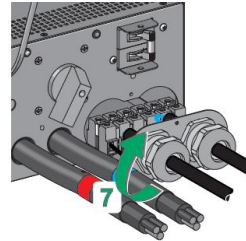

Close the I/O box terminal

MBP6KiG2 used with 5000VA and 6000VA UPS

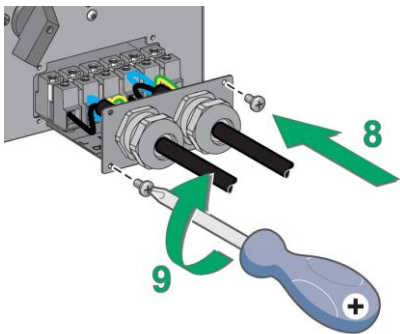

MBP11KiG2 used with 8000VA and 11000VA UPS

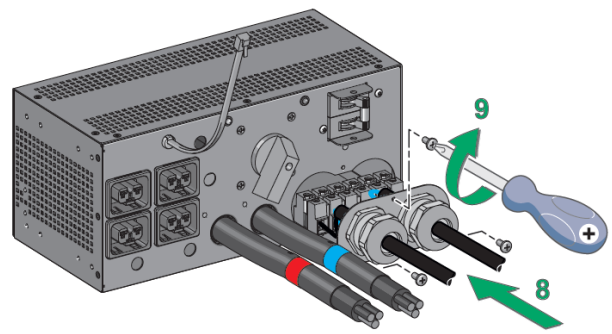

Connection between MPB and UPS

 For the electrical connection on the UPS side, follow the steps described in the chapter "Hardwired connection" Connect the MBP cord set (For 6k MBP only)

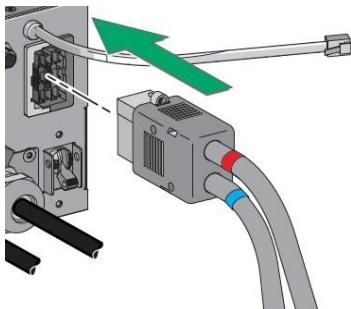

Connect the MBP detection cable to the UPS

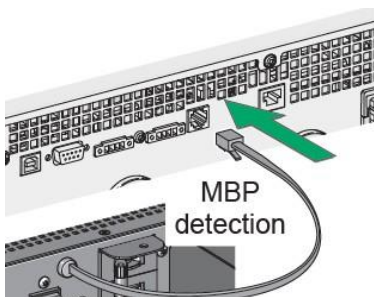

Power up your installation

Switch on the input circuit breaker of your installation. The installation is powered up and can be used.

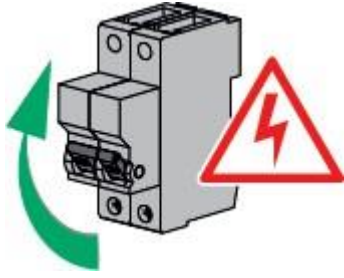

5 Interfaces and communication

5.1 Control panel

The screen provides useful information about the UPS itself, load status, events, measurements and settings.

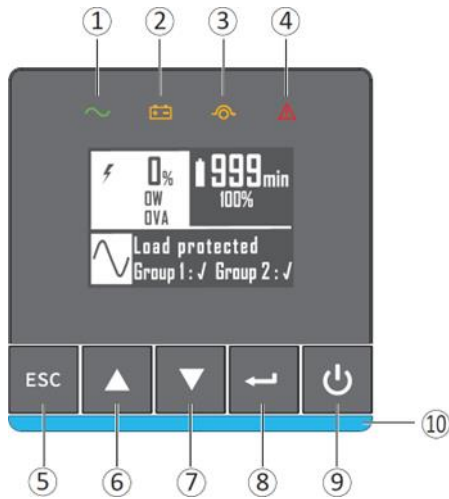





- ① Power ON indicator (green)
- ② On battery indicator (orange)
- ③ On bypass indicator (orange)
- ④ Alarm indicator (red)
- ⑤ Escape
- ⑥ Up
- ⑦ Down
- ⑧ Enter
- ⑨ On/Off button
- ⑩ Led bar

Led indicator

The following table shows the indicator status and description :

The LED bar ⑩ has been implemented to provide a quick visual reference of UPS status "at-a-glance".

Indicator	Status	Description
 Green	On	The UPS is "ON" and the load is protected.
 Orange	On	The UPS is in battery mode and the load is protected.
 Orange	On	The UPS is in bypass mode.
 Red	On	The UPS has an active alarm or fault. See troubleshooting page for additional information.
Led bar	Static blue	The UPS is "ON" and the load is protected.
	Flashing blue	The UPS is on battery or the battery service age warning is reached.
	Static red	The UPS has an active alarm or fault.
	Flashing red	The UPS output has stopped due to a fault.

5.2 LCD description

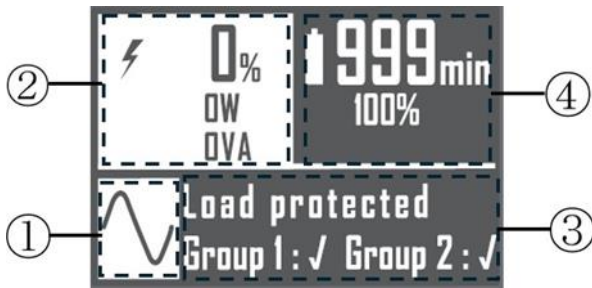







- ① Operation status
- ② Load/equipment status
- ③ Efficiency and load group information
- ④ Battery status

By default, or after 5 minutes of inactivity, the LCD displays the screen saver.

The backlight LCD automatically dims after 5 minutes of inactivity. Press any button to restore the screen.

i Note. If other indicator appears, see troubleshooting page for additional information.

The following table describes the status information provided by the UPS :

Operation status	Possible cause	Action
Standby mode 	The UPS is OFF, waiting for start-up command from user	Equipment is not powered until button  is pressed during start up and the green "normal mode" LED indicator is illuminated.
Normal mode 	The UPS is operating normally.	The UPS is powering and protecting the equipment.
On Battery  One beep every 10 seconds	A utility failure has occurred and the UPS is operating in Battery mode.	The UPS is powering the equipment with battery power. Prepare your equipment for shutdown.
End of backup time  1 beep every 3 seconds Single beep	The UPS is in Battery mode and the battery is running low.	This warning is approximate, and the actual time to shutdown may vary significantly. Depending on the UPS Load, the "Battery Low" warning may occur before the battery reaches 20% capacity remaining.
High Efficiency mode 	The UPS is operating in High Efficiency mode.	The UPS is powering and protecting the equipment.
Bypass mode 	An overload or a fault has occurred, or a command has been received, and the UPS is on Bypass mode.	Equipment is powered but not protected by the UPS.

5.3 Display functions

Press the Enter (↵) button to activate the menu options. Use the two middle buttons (▲ and ▼) to scroll through the menu structure. Press the Enter (↵) button to select an option. Press the (ESC) button to cancel or return to the previous menu.

Menu map for display functions

Main menu	Submenu	Display information or Menu function
Measurements		Load: W, A, VA, pF [Input/Output] : V, Hz [Efficiency] : % [Battery Info] : %, min, V, Age service, Age Warning, Replacement Battery Packs [Average power usage] : Total Wh [Cumulative power] : Total KWh, Since
Control	Go to Bypass	The user has the possibility to force the Ups to go to Bypass mode, only if the Ups mode is in Online or in battery mode.
	Load Segments	Group 1: ON / OFF Group 2: ON / OFF These commands overrule user settings for load segments.
	Start battery test	Starts a manual battery test (possible if load >10% and battery >80%)
	Change battery	Disable charger, Replace battery, Update settings
	Connectivity test	Dry contacts test, Relay card test, Line failure test, Battery low test
	Functions reset	Reset fault state, Reset power usage, Reset battery life, NMC Card reset, Restore factory settings
Settings	Local settings	Sets product general parameters, see User settings
	Input / output settings	Sets input and output parameters
	ON / OFF settings	Sets ON / OFF conditions
	Battery settings	Sets battery configuration
	Communication settings	Sets communication parameters
Event log	View Alarms	Displays the alarms stored
	View Events	Displays the events stored
	View All	Displays the faults, alarms and events stored
	Reset All	Clears the faults, alarms and events stored
Fault log	Fault list	Displays the faults stored
	Reset fault list	Clears faults
Identification		Type / Model / Part Number / Serial Number / UPS Firmware / NMC Firmware / IPV4 Address / IPV6 Address / Com card MAC Address /Detected accessories
Registration		Links to Eaton registration website

5.4 User settings

The following table displays the options that can be changed by the user.

Main Menu	Submenu	Available settings	Default settings
Local settings	Language	[English] [Français] [Deutsch] [Español] [Português] [Italiano] [Simplified Chinese] [Japanese] Menus, status, notices and alarms, UPS fault, Event Log data and settings are in all supported languages.	[English] Automatic message for user configuration when UPS is powered for the first time.
	Date / time	Format: [International] [US]	[International]
	LCD	Modify LCD screen brightness and contrast to be adapted to room light conditions.	[0]
	Audible alarm	[Enabled] [Disabled on battery] [Always disabled] Enable or disable the buzzer if an alarm occurs.	[Enabled]
		Level: [High] [Low]	[High]
Protected access	[Enabled] [Disabled] Allow the user to lock the settings modification.	[Disabled]	
In/Out settings	Output voltage	[200 V] [208 V] [220 V] [230 V] [240 V]	[230 V]
	Output frequency	Mode: [Normal] [Converter] [Marine] Frequency can be changed in Frequency [Converter] mode In [Marine] mode output frequency follows input frequency	[Normal]
	Output Mode	Mode: [Industrial] [IT] [Custom] Overload: [Inv>Stop] [Inv>BP] [Inv>BP>Inv] Short-circuit: [Inv>Stop] [Inv>BP] [Inv>BP>Inv]	[Industrial] [Inv>BP>Inv] [Inv>Stop]
	Input V hysteresis	Sets input voltage hysteresis from [1] to [10V]	[10V]
	High efficiency	[Enabled] [Disabled] Power the output from Bypass for high efficiency	[Disabled]
	Bypass settings	[Volt low] [Volt high] [Qualify] [Hz synch] [Unsynch]	[160V]; [276V]; [Always]; [5%]; [Half cycle]

Main Menu	Submenu	Available settings	Default settings
	Load segments	[Auto start delay]	UPS:[No delay]; Group1:[3s]; Group2:[6s]
		[Auto shutdown delay]	UPS:[Disabled]; Group1: [Disabled]; Group2: [Disabled]
	Overload prealarm	[10%] ... [102%] Load % when overload alarm occurs	[102%]
	Power Limit	[Enabled] [Disabled] Disabled/ Enabled UPS power limit mode on 5K/6K/ 8K/11K. If Enabled, nominal power change to 4000VA/4000watt	[Disabled]
	Dust Proofing	[Enabled] [Disabled] If set to Enabled, a 40% derating will be applied to allow functioning with a dust filter	[Disabled]
	Redundancy mode	[Unitary UPS] [Hot Standby]	[Unitary UPS]
ON/OFF settings	Start/Restart	[Cold start] [Auto restart] [Auto start] [Start on bypass]	[Cold start] : ON [Auto restart] : ON [Auto start] : OFF [Start on bypass] : OFF
	Forced reboot	[Yes] [No] [Timer] [10s] ... [180s] When mains recovers during a shutdown sequence: If set to Enabled, shutdown sequence will complete and wait 10 seconds prior to restart. If set to Disabled, shutdown sequence will not complete, UPS stays on.	[Yes] [10s]
	Energy saving (W,%, delay)	[Yes] [No] [Time] [0min] ... [15min] [Level] [10W] ... [1000W- Nominal Power] If Enabled, UPS will shut- down after defined duration of back-up time, if load is less than set value.	[No] [5min] [1000W]
	Sleep Mode	[Enabled] [Disabled] [Timer] [10min] ... [120min] If Disabled, LCD and communication will turn OFF immediately after UPS is OFF. If Enabled, LCD and communication stays ON for the set time period after UPS is OFF (default 90 min).	[Enabled] [90min]

Main Menu	Submenu	Available settings	Default settings
	Site Wiring Fault	[Enabled] [Disabled] Prevents the UPS from starting if the phase and neutral wires are swapped.	[Disabled]
	Power Off alert	[Enabled] [Disabled] If enabled, activates a confirmation screen that requires user confirmation after pressing the power button, before UPS shutdown occurs. Remote shutdown, ROO, RPO, Input signals will never request user confirmation, even if the setting is enabled	[Yes]
	Bypass standby	[Enabled] [Disabled]	[Enabled]
Battery settings	Auto battery test	In ABM® cycling mode: [No test] [Every ABM® cycle] In constant charge mode: [No test] [Daily] [Weekly] [Monthly]	[Every ABM® cycle] [Weekly]
	Battery age warning	[Disabled][Preventive] [6-120][Predictive] If Preventive, the UPS displays a battery replacement reminder through the front LCD and any installed network communication card after the indicated timeframe has elapsed (default 48 months).	[Predictive] Refer to Advanced Battery Management + section
	Low battery warning	[Capacity] [0%] ... [100%] [Runtime] [0min] ... [60min] The alarm triggers when the set percentage of battery capacity or remaining back-up time is reached.	[0%] [3min]
	Restart batt. level	[0%] ... [100%] Automatic restart will occur only when the set percentage of battery charge is reached, and "Auto Restart" is enabled and set to ON. A setting of 0% allows immediate automatic restart when utility returns after a UPS shutdown due to an extended power outage.	[0%]
	Battery charge mode	[ABM® cycling] [Constant charge]	[ABM® cycling]
	External battery	[Auto detection] [Manual EBM set.] [Manual battery set.][No Battery]	[Auto detection] Using standard EBM, UPS automatically detects the number of EBM connected

Main Menu	Submenu	Available settings	Default settings
	Charger current	[2A] [4A] [6A][8A] It is the maximum charging current. The UPS will adapt charger current to reduce charging time and maximize battery life.	[8A]
	Deep disch. protect.	[Enabled] [Disabled] If set to Enable, the UPS operates within the normal design range of the battery during discharge. If set to Disable, the UPS allows deeper battery discharge to extend battery runtime at the expense of long-term battery life (warranty is also void if set to disable).	[Enable]
Comm settings	Input signals	[ROO] [RPO] [DB9-4] Sets Input signals parameters (function, delay, operation) through external contact connectors or RS232 port.	
		ROO port: - [Function]: [No] [ROO] [RPO] [Building alarm] [Forced bypass] [On generator] [Remote shutdown] - [Delay]: [0s] ... [999s] [Active]: [Open] [Closed]	[No] [0s] [Closed]
		RPO port: - [Function]: [No] [ROO] [RPO] [Building alarm] [Forced bypass] [On generator] [Remote shutdown]	[No] [0s] [Open]
		- [Delay]: [0s] ... [999s] - [Active]: [Open] [Closed] DB9-4 port: [Function]: [No] [ROO] [RPO] [Building alarm] [Forced bypass] [On generator] [Remote shutdown]	[No] [0s] [High]
		- [Delay]: [0s] ... [999s] - [Active]: [Low] [High]	

5.5 Advanced Battery Management +

Eaton ABM+ (Advanced Battery Management) implements a machine learning algorithm providing battery health status.

When set to predictive mode, the UPS will be able to provide an accurate remaining service time prediction based on real UPS usage condition.

A battery replacement warning (that includes the battery P/N) will be triggered at the most appropriate time to help user keeping the UPS operating at its best performance.

5.6 Communication ports

Connection of RS232 or USB communication port

1. Connect the RS232 or USB communication cable to the serial or USB port on the computer equipment.
2. Connect the other end of the communication cable to the USB or RS232 communication port on the UPS



The UPS can now communicate with Eaton power management software.

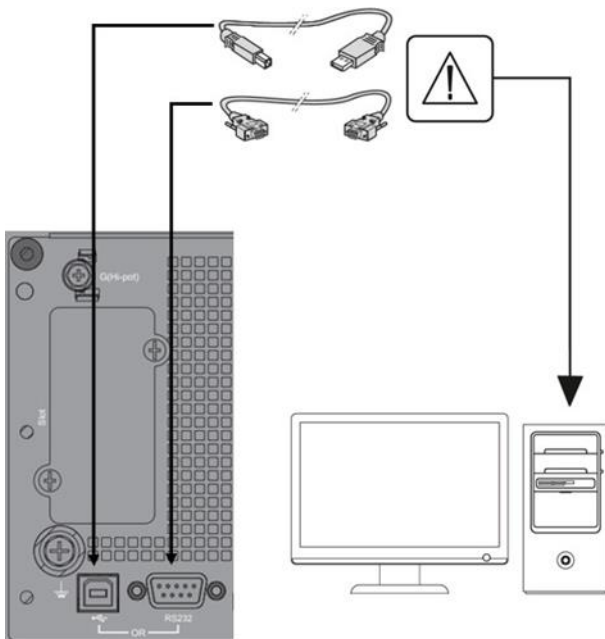

Characteristics of the contact RS232 communication port

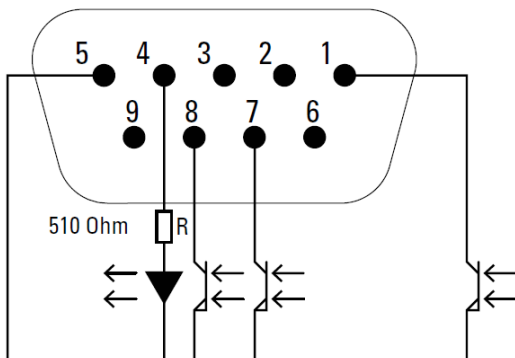

Contact characteristics (optocoupler):

- Voltage: 48 V DC max
- Current: 25 mA max
- Power: 1.2 W

Pin	Signal	Direction	Function
1	Bat low	Output	Low Battery Output
2	TxD	Output	Transmit to external device
3	RxD	Input	Receive from external device
4	I/P SIG	Input	-
5	GNDS	-	Signal common tied to chassis
6	NC		Not Connected
7	UPS OK	Output	UPS OK
8	BAT mode	Output	UPS on battery mode
9	+5V	Output	Power supply for external signal or options

Installation of the communication cards

The UPS is delivered with a Network-M3 card already mounted in the slot 1.

If you need to change the card or to add a second communication card (a second slot is available on the 8000VA and 11000VA only), follow the below instructions:

Note: It is not necessary to shutdown the UPS before installing a communication card.

5000 / 6000 VA

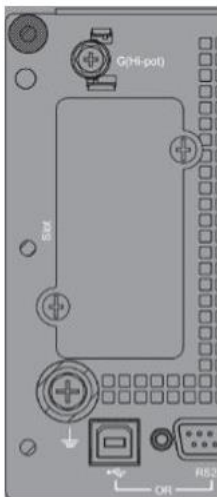

8000 / 11000 VA

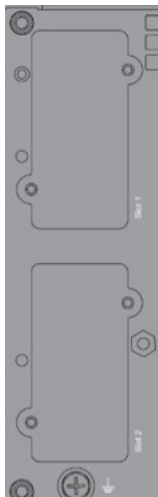

1. Remove the slot cover secured by screws
2. Insert the communication card in the slot.
3. Secure the card cover with the two screws to connect the comm card to the ground.

Connectivity cards

Connectivity cards allow the UPS to communicate in a variety of networking environments and with different types of devices. The 9PX G2 models have one available communication bay for the following connectivity cards:

- **Gigabit Network card (Network-M3)** : provides a Gigabit Ethernet connection and enables secure UPS monitoring over HTTPS web browser interface, SNMP v1/v3 protocol and email alarms. In addition, up to 3 Environmental Monitoring Probes can be attached to obtain humidity, temperature, smoke alarm, and security information.
- **Industrial Gateway card (INDGW-M2)** : Provides Modbus RTU and Modbus TCP communication support in addition to the same secure UPS monitoring, management and sensor capability as the Gigabit Network card.
- **Relay-MS card** : provides isolated dry contact (Form-C) relay outputs for UPS status: Utility failure, Battery low, UPS alarm/OK, or on Bypass.
- **INDRELAY-MS** : The Industrial relay Card-MS (INDRELAY-MS) provides a simple way to remotely input UPS information to an alarm system, PLC or a computer system via dry contacts. It offers five isolated dry contact outputs and one isolated dry contact input.

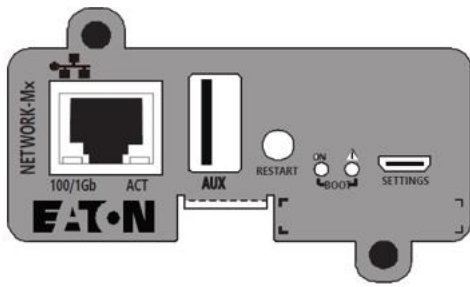

Network-M3



Relay-MS Card

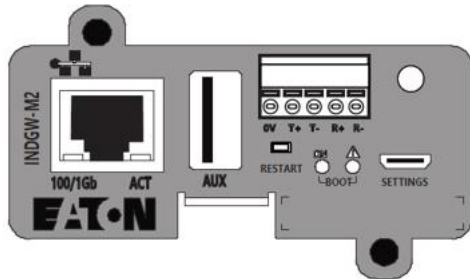

INDGW-M2

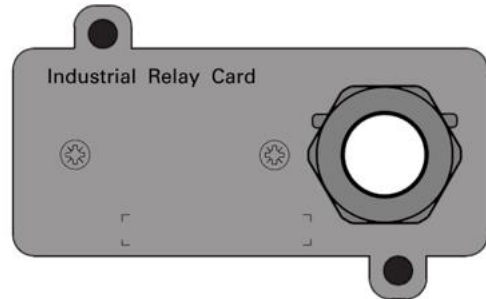

INDRELAY-MS

5.7 UPS remote control functions

Programmable signal inputs

The 9PX G2 incorporates several programmable signal inputs: one Remote Power Off (RPO) input terminal, one Remote On/Off (ROO) input terminal, one RS-232 input (pin-4).

Signal inputs can be configured (see Settings > Comm settings > Signal Input) to have one of the following functions:

Function	Description
No	No function. (Please choose a function if you want to use input signal.)
RPO	Remote Power off (RPO) is used to shutdown the UPS remotely.
ROO	Remote On/Off allows remote action of a button or other interface to switch On/ Off the UPS. (Cold start is prohibited while using the ROO function.)
Forced bypass	If feeding the load the unit goes to bypass operation and stays there regardless of the bypass state until the input is inactivated.
Building alarm	Active input generates an alarm "building alarm".
On generator	Active input disables synchronization and disable bypass output.
Shutdown commands	Active input turns UPS output (or outlet groups) off after a user defined shutdown delay but keeps on charging batteries according to a selected charging scheme; inactive input does not abort shutdown countdown. Depending on the "Restart" parameter (see Settings > Comm Settings > Shutdown commands) the unit may startup automatically.

 **Warning:** signal inputs have no function by default; please choose a function through the LCD (Settings > Com settings > Input signals).

See below 2 examples of configuration with RPO terminal used as RPO function and ROO terminal use as

ROO function:

Remote Power Off (RPO)

RPO is used to shutdown the UPS remotely when the contact is open. This feature can be used for shutting down the load and the UPS by thermal relay, for example, in the event of room over temperature. When RPO is activated, the UPS turns off the output and shuts down all power converters immediately (except for logic power). The UPS remains "ON" to alarm the fault.

The RPO circuit is a safety extra low voltage (SELV) circuit. This circuit must be separated from any hazardous voltage

circuits by reinforced insulation.

- The RPO must not be connected to any utility connected circuits. Reinforced insulation to the utility is required. The RPO switch must be a dedicated latching-type switch not tied into any other circuit. The RPO signal must remain active for at least 250 ms for proper operation.
- To ensure the UPS stops supplying power to the load during any mode of operation, the input power must be disconnected from the UPS when the Remote Power Off function is activated.

RPO connections:

Leave the RPO connector installed in the RPO port on the UPS even if the RPO function is not needed.

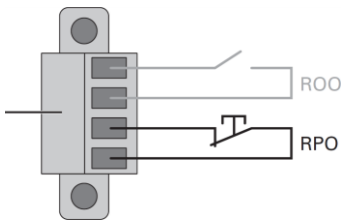

RPO	Comments
Connector type	Terminal, 14 AWG Maximum wires
Terminal rating	60 V DC/30 V AC 20 mA max

Remote On/Off (ROO)

- Remote On/Off allows remote action of button to switch On/Off the UPS.
- When contact changes from open to closed, the UPS is switched-on (or stays On).
- When contact changes from closed to open, the UPS is switched-off (or stays Off).
- On/Off control via button has priority over the remote control.

i The ROO function is only active after the first use of the "Remote OFF" function.

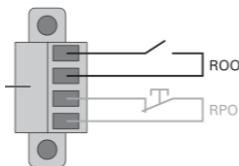

ROO	Comments
Connector type	Terminal, 14 AWG Maximum wires
Terminal rating	60 V DC/30 V AC 20 mA max

Remote control connection and test

⚠ Warning. This connector must only be connected to SELV (Safety Extra-Low Voltage) circuits.

1. Check the UPS is shut down and the electrical supply network disconnected.
2. Remove RPO connector from the UPS by removing the screws.
3. Connect a normally closed volt-free contact between the two pins of connector.

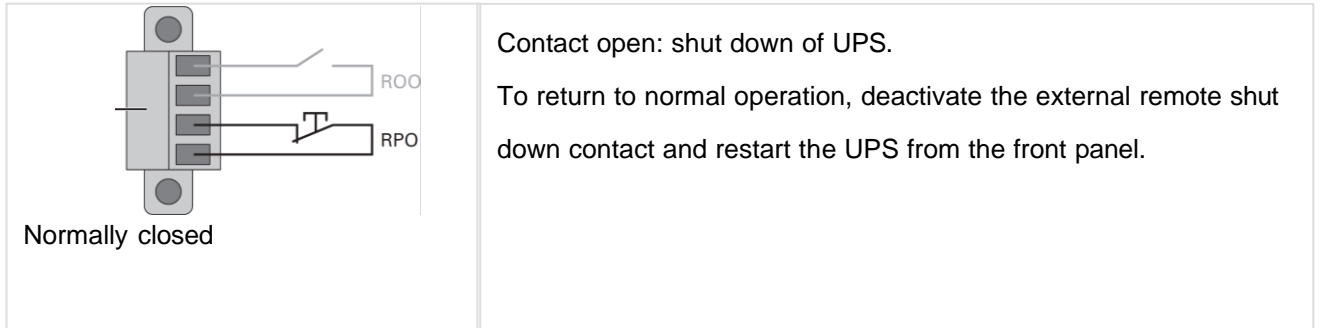

4. Plug the RPO connector into the back of the UPS and fix the screws.
5. Connect and restart the UPS according to the previously described procedures.
6. Activate the external remote shut down contact to test the function.

Always test the RPO function before applying your critical load to avoid accidental load loss.

Programmable signal outputs

The 9PX G2 incorporates several programmable signal outputs: Two relay outputs and two optocoupler outputs (DB9 pins 1, 7 and 8). Signal outputs can be configured (see Settings > Comm settings > Output Signals) to report the following information:

Signal	Default assignment	Description
On battery (On Bat)	DB9-Pin 8	UPS is in battery mode
Low battery (Low Bat)	DB9-Pin 1	UPS is in battery mode and has reached the low battery alarm threshold
Battery fault	Relay output (1)	Battery fault
UPS OK	DB9-Pin 7	Load is powered with no alarm (from inverter or bypass)
Load protected	-	UPS is on inverter, with no alarm and ready to go to battery
Load powered	-	Load is powered (from inverter or bypass)
General alarm	-	Choose events that will trigger this alarm through the LCD (Settings > Comm settings > General alarm). For more information on possible events please look at User settings
OVL pre-alarm	-	Overload pre-alarm
Bat disconnected	-	Battery is disconnected
Bypass	Relay output (1)	UPS is operating in Bypass mode

(1) Relay output:

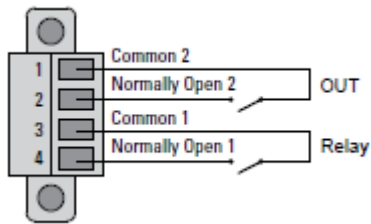

5.8 Eaton Intelligent Power Software suite

Eaton Intelligent Power Software suite is available from eaton.com/downloads.

Eaton Software suite provides up-to-date graphics of UPS power and system data and power flow.

It also gives you a complete record of critical power events, and it notifies you of important UPS or power information.

If there is a power outage and the 9PX Gen2 UPS battery power becomes low, Eaton Software suite can automatically shut down your computer system to protect your data before the UPS shutdown occurs.

5.9 Cybersecurity

Eaton is committed to minimizing the Cybersecurity risk in its products and employs cybersecurity best practices and the latest cybersecurity technologies in its products and solutions, making them more secure, reliable and competitive for our customers. Eaton also offers Cybersecurity Best Practices whitepapers to its customers, referenced at www.eaton.com/cybersecurity.

6 Operation

6.1 Start-up and normal operation







Check that the indications on the name plate located on the back of the UPS meets to the AC power source and the true electrical consumption of the total load.

Battery charge

The UPS charges the battery as soon as it is connected to the AC outlet, whether the ON/OFF button is pressed or not. It is recommended that the UPS be permanently connected to the AC power supply to ensure the best possible autonomy.





To start the UPS:

1. Verify that the UPS power cord is plugged in.
2. There is a single buzzer indication.
3. Press the  button on the UPS front panel for few seconds.
4. Check the UPS front panel display for active alarms or notices. Resolve any active alarms before continuing; if the  indicator illuminates in red, do not proceed until all alarms are clear (see "[Troubleshooting](#)" section). Check the UPS status from the front panel to view the active alarms. Correct the alarms and restart if necessary.
5. Verify that the  indicator illuminates in green, indicating that the UPS is operating normally and any loads are powered and protected. The UPS should be in Normal mode.
6. The UPS will make a first battery test, the  will blink for few seconds, this behavior is normal.



On the first startup of the UPS, you will need to configure the output voltage and time of the UPS.

To start the UPS:

1. Verify that the UPS power cord is plugged in.
2. The UPS front panel display illuminates and shows Eaton logo.
3. Verify that the UPS status screen shows .
4. Press the  button on the UPS front panel for at least few seconds.
5. Check the UPS front panel LED for active alarms or notices. Resolve any active alarms before continuing; if the  indicator is on, do not proceed until all alarms are clear (see "[Troubleshooting](#)" section). Check the UPS status from the front panel to view the active alarms. Correct the alarms and restart if necessary.
6. Verify that the  indicator illuminates solid, indicating that the UPS is operating normally and any loads are powered and protected. The UPS should be in Normal mode.

6.2 Starting the UPS on battery



Before using this feature, the UPS must have been powered by utility power with output enabled at least once.

Battery start can be disabled. See the "Cold start" setting in "[ON/OFF Settings](#)". To start the UPS on battery:

1. When the UPS is disconnected from the AC power source, press the  button on the UPS front panel. The UPS transfers from Standby mode to Battery mode.

The  indicator illuminates solid.

The  indicator blinking and the buzzer snooze.

The UPS supplies power to your equipment.

2. Check the UPS front panel display for active alarms or notices besides the "Battery mode" and related notifications that indicates missing utility power. Resolve any active alarms before continuing. See "[Troubleshooting](#)".

Check the UPS status from the front panel to view the active alarms. Correct the alarms and restart if necessary.

6.3 UPS start-up with HotSwap MBP



Verify that the total equipment ratings do not exceed the UPS capacity to prevent an overload alarm.

1. Check that the UPS is correctly connected to the HotSwap MBP.



If the UPS is equipped with outlets, those outlets can no longer be used (loads can only be connected to the MBP outlets or the MBP Output terminal blocks)

2. Verify that the MBP terminal blocks are connected to the AC source.
3. Check that the MBP manual Bypass switch is to the "**Bypass**" position.

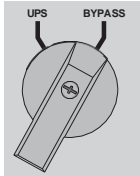

4. Set the upstream circuit breaker (not provided) to the "I" (On) position to switch on the utility power.
5. Verify that the "**Bypass mode**" red light of the MBP goes On, indicating that the load is now powered by the AC source.
6. Set the Normal AC source switch of the MBP to the "I" (On) position.
7. Verify that the UPS is correctly powered (UPS display panel illuminates).
8. Press the UPS "**ON**" button to start the UPS.
9. Put the UPS in "**Bypass mode**" ("Control -> Go to bypass").
10. Verify that the UPS is on Bypass mode by checking UPS display panel.
11. Verify that the "**UPS mode**" green light of the MBP goes On, indicating that the UPS output power is available on the MBP.



Important: do not continue to next step if the "UPS mode" green light of the MBP is still Off (the load will be lost).

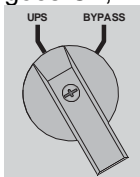

12. Set the MBP manual Bypass switch to the "**UPS**" position: the "**Bypass mode**" red light of the MBP goes Off, indicating that the load is now powered by the UPS.



13. Put the UPS in "**Normal mode**". ("Control -> Go back normal")
14. Check that the UPS is in Online mode by checking UPS display panel. The load is now protected by the UPS.

6.4 UPS shutdown

To shut down the UPS:

Press the  button on the front panel for two seconds. A confirmation message will appear. When confirmed, the UPS starts to beep and shows a status of "UPS shutting OFF...". The UPS then transfers to Standby mode, and the  indicator turns off. The UPS starts to beep and the indicator is blinking. The UPS then transfers to Standby mode, and the indicator turns off.

6.5 Operating modes

The Eaton 9PX Gen2 front panel indicates the UPS status through the UPS indicators located above the LCD screen.

LED indicator:

Normal mode

When the green  symbol is illuminated, the UPS is providing protected AC power output. The LED bar is illuminated in static blue. The UPS monitors and charges the batteries as needed and provides power protection to your

equipment. Optional High Efficiency and Energy Saving settings minimize heat contribution to the rack environment. See user settings.

Battery mode

When the UPS is operating during a power outage, the alarm beeps once every ten seconds and the indicator  illuminates solid. The LED bar is flashing blue.

The necessary energy is provided by the battery.

When the utility power returns, the UPS transfers to Normal mode operation while the battery recharges. If battery capacity becomes low while in Battery mode, the audible alarm beeps faster.

This warning is approximate, and the actual time to shutdown may vary significantly; shutdown all applications on connected equipment due to imminent UPS shutdown.

When utility power is restored after the UPS shuts down, the UPS automatically restarts.

Low-battery warning

- The  indicator illuminates solid.
- The audio alarm beeps every three seconds.
- The LED bar illuminates red

The remaining battery power is low. Shut down all applications on the connected equipment because automatic UPS shutdown is imminent.

Low-battery warning

- The  indicator blinking quickly.
- The audio alarm beeps every 1.5 seconds.

The remaining battery power is low. Shut down all applications on the connected equipment because automatic UPS shutdown is imminent.

End of battery backup time

- LCD displays "End of backup time".
- All the LEDs go OFF.
- The audible alarm stops.

Bypass mode

In the event of a UPS overload or internal failure, the UPS transfers your equipment to utility power. Battery mode is not available and your equipment is not protected; however, the utility power continues to be

passively filtered by the UPS. The by-pass indicator illuminates in orange.

Depending on overload conditions, the UPS remains in Bypass mode for at least five seconds and will stay in this mode if three transfers to Bypass occur within 20 minutes.

The UPS transfers to Bypass mode when:

- the user activates Bypass mode through the front panel,
- the UPS detects an internal failure,
- the UPS has an overtemperature condition,
- the UPS has an overload condition listed.

The UPS shuts down after a specified delay for overload conditions listed.

6.6 Return of AC input power

Following an outage, the UPS restarts automatically when AC input power returns (unless the restart function has been disabled) and the load is supplied again.

6.7 Configuring battery settings

Automatic battery test

Automatic battery tests are done every in constant charging mode and at each cycle in ABM® mode. The tests frequency can be modified.

During the test, the UPS transfers to Battery mode and discharges the batteries for 10 seconds under load. Battery mode is not displayed and battery low alarm is not activated during a battery test.

The battery test may be postponed due to bad conditions or failed if battery is not ok.

Low battery warning

During discharge, the low battery alarm is activated if the remaining runtime goes below 3 minutes or less than the setting capacity threshold (0% by default).

This threshold can be modified.

External battery setting

The number of Extended Battery Module is automatically detected, or can be set manually in number of EBM or in Ah.

Deep discharge protection

This setting is recommended to avoid damaging the battery. Warranty is void if deep discharge protection is disabled.

6.8 Setting high efficiency mode

In High Efficiency mode, the UPS operates normally on Bypass and transfers to Online (or Battery) mode in less than ten ms when utility fails. Transfers to High Efficiency mode will be active after five minutes of Bypass voltage monitoring: if Bypass quality is not in tolerance, then the UPS will remain in Online mode.



Eaton recommends using the HE mode only to protect IT equipment.

To set the High Efficiency mode:

1. Select Settings, In/Out settings, and High Efficiency mode.
2. Select Enabled and Enter to confirm.
3. The UPS transfers to High Efficiency mode after five minutes.

7 UPS maintenance

7.1 Equipment care

For the best preventive maintenance, keep the area around the equipment clean and dust free. If the atmosphere is very dusty, clean the outside of the system with a vacuum cleaner.

For full battery life, keep the equipment at an ambient temperature of 25 °C (77 °F).

The batteries are rated for a 3-5 year service life. The length of service life varies, depending on the frequency of usage and ambient temperature (life divided by 2 each 10 °C above 25 °C).

If the UPS requires any type of transportation, verify that the UPS is turned off.

Batteries used beyond expected service life will often have severely reduced runtimes. Replace batteries at least every 4 years to keep units running at peak performance.

Batteries runtime will be reduced at low temperature (below 10 °C).

7.2 Storing the equipment

If you store the equipment for a long period, recharge the battery every 6 months by connecting the UPS to utility power. The internal batteries charge to 90% capacity in less than 3 hours. However, Eaton recommends that the batteries charge for 48 hours after long-term storage.

Check the battery recharge date on the shipping carton label. If the date has passed and the batteries were never recharged, do not use them. Contact your service representative.

7.3 When to replace batteries

Eaton 9PX Gen2 batteries have an expected life span of 3-5 years.

Preventive Mode

After 4 years of operation, the UPS will provide a battery replacement notification reminding you that your batteries are nearing the end of their useful life. You should take proactive steps to ensure you replace your batteries for optimal operation and reliability.

Predictive Mode (ABM+)

Based on real UPS usage condition, a battery replacement warning (that includes the battery P/N) will be triggered at the most appropriate time to help you keeping the UPS operating at its best performance. When battery he "Battery Age Status" will change from "Healthy" to "Warning and Replace". You will have 2 months to replace your batteries for optimal operation and reliability.

i Contact your service representative to order new batteries.

Battery reference can be accessed through the LCD (Measurements > Battery).

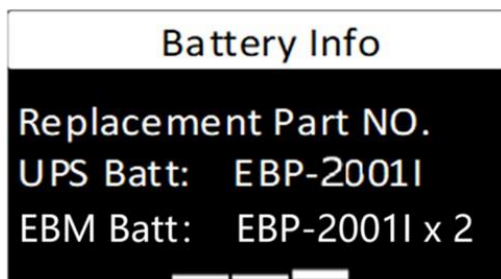

7.4 UPS replacement with HotSwap MBP

 UPS Removing (please follow the MANDATORY step below).

 UPS replacement must be performed by qualified person only.

MBP6KiG2



1. Put the UPS in "**Bypass mode**"

2. Verify that the UPS is on Bypass mode by checking UPS display panel

3. Set the MBP manual Bypass switch to "**Bypass**" position. The "**Bypass mode**" red light of the MBP goes On, indicating that the load is supplied directly by AC source

4. Switch the Normal AC source switch of the MBP to the "0" (Off) position and wait 30 seconds

5. UPS stops, the UPS can now be disconnected, as described below:

- First disconnect the I/O cord Set from the MBP, after removing the 2 screws.

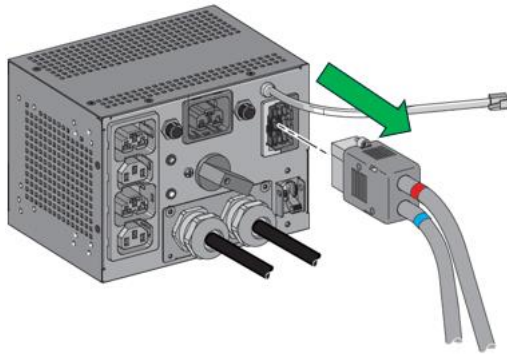

- After opening the UPS I/O terminal blocks cover, check if hazardous voltage is no longer present on UPS terminal blocks by using a voltage absence tester.

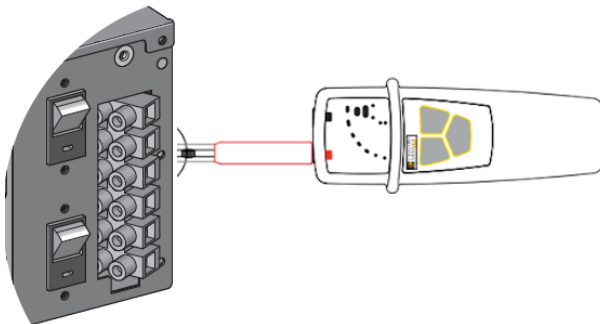

- Disconnect the 2 power cables, and the MBP detection cable, of the MBP I/O cord Set
- Replace the UPS.



Hazardous voltage and lost load risk: do not manipulate the MBP manual Bypass switch without UPS connected via the I/O cord Set.

MBP11KiG2:

 UPS replacement must be performed by qualified person only.

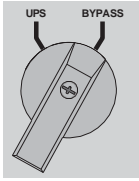

1. Put the UPS in "**Bypass mode**"
2. Verify that the UPS is on Bypass mode by checking UPS display panel
3. Set the MBP manual Bypass switch to "**Bypass**" position. The "**Bypass mode**" red light of the MBP goes On, indicating that the load is supplied directly by AC source, or Bypass AC source
4. Switch the Normal AC source switch and the Bypass AC source switch (*) of the MBP to the "0" (Off) position and wait 30 seconds
5. UPS stops, the UPS can now be disconnected, as described below:
 - First lock the Normal AC source switch of the MBP to the "0" (Off) position (the switch protection frames are able to fit a cable tie or a metallic locker).

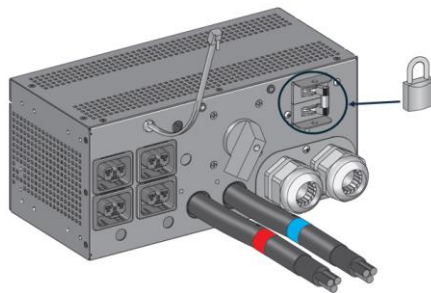

- After opening the UPS I/O terminal blocks cover, check if hazardous voltage is no longer present on UPS terminal blocks by using an electrical safety tester.

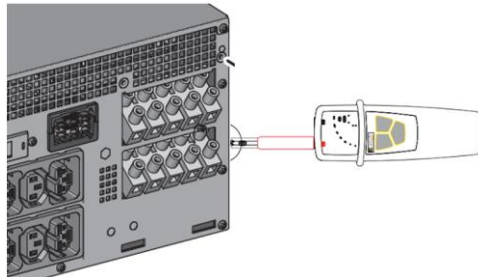

- Disconnect the MBP power cables, and the MBP detection cable.
- On each MBP power cables just disconnected from the UPS, link the wires together (line and neutral wires linked to ground wire).

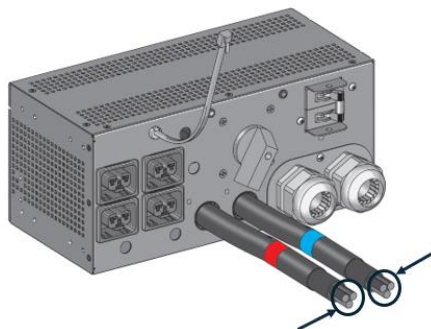

- Replace the UPS



Hazardous voltage and lost load risk: do not manipulate the MBP manual Bypass switch without UPS connected to the MBP power cables.

Return to normal operation:

1. Check that the new UPS is correctly connected to the MBP, as described below:

MBP6KiG2:

- After opening the UPS I/O terminal blocks cover, connect to UPS the 2 power cables, and the MBP detection cable.
- Connect the I/O cord Set connector to the MBP, and secure it by fixing the 2 locking screws

MBP11KiG2:

- First check that the Normal AC source switch of the MBP is still locked to the "0" (Off) position
- Remove the previously installed safety wires links on each MBP power cables
- After opening the UPS I/O terminal blocks cover, connect to UPS the MBP power cables, and the MBP detection cable
- Unlock the Normal AC source switch of the MBP.

2. Set the Normal AC source switch of the MBP to the "I" (On) position

3. Verify that the UPS is correctly powered (UPS display panel illuminates)

4. Press the UPS **"ON"** button to start the UPS

5. Put the UPS in **" Bypass mode"**

6. Verify that the UPS is on Bypass mode by checking UPS display panel

7. Verify that the **"UPS mode" green light** of the MBP goes On, indicating that the UPS output power is available on the MBP.



Important: do not continue to next step if the **"UPS mode" green light** of the MBP is still Off (the load will be lost)

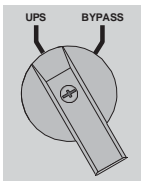

8. Set the **MBP** manual Bypass switch to the **"UPS" position**: the **"Bypass mode" red light** of the MBP goes Off, indicating that the load is now powered by the UPS

9. Put the UPS in **"normal mode"**

Check that the UPS is in Online mode by checking UPS display the load is now protected by the UPS

7.5 UPS Maintenance with HotSwap MBP

Go to maintenance Bypass operation (please follow the MANDATORY steps below):

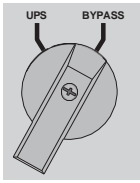

1. Put turn to normal
2. Verify that the UPS is on Bypass mode by checking UPS display panel
3. Set the MBP manual Bypass switch to "**Bypass**" position. The "**Bypass mode**" **red light** of the MBP goes On, indicating that the load is supplied directly by AC source
4. Proceed to maintenance operations on UPS

Return to normal operation:

1. Verify that the UPS is on Bypass mode by checking UPS display panel
2. Verify that the "**UPS mode**" **green light** of the MBP is On, indicating that the UPS output power is available on the MBP



Important: do not continue to next step if the "**UPS mode**" **green light** of the MBP is Off (the load will be lost)

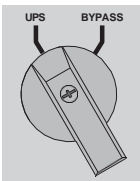

3. Set the MBP manual Bypass switch to the "**UPS**" **position**: the "**Bypass mode**" **red light** of the MBP goes Off, indicating that the load is now powered by the UPS
4. Put the UPS in "**normal mode**"
5. Check that the UPS is in Online mode by checking UPS display panel the load is now protected by the UPS

7.6 Recycling the used equipment

Contact your local recycling or hazardous waste center for information on proper disposal of the used equipment.

eaton.com/recycling

Do not dispose the battery or batteries in a fire. Batteries may explode. Proper disposal of batteries is required. Refer to your local codes for disposal requirements.

Do not open or mutilate the battery or batteries. Released electrolyte is harmful to the skin and eyes. It may be toxic.



Do not discard the UPS or the UPS batteries in the trash. This product contains sealed, lead acid batteries and must be disposed of properly. For more information, contact your local recycling/ reuse or hazardous waste center.



Do not discard waste electrical or electronic equipment (WEEE) in the trash. For proper disposal, contact your local recycling/reuse or hazardous waste center.

8 Troubleshooting

The Eaton 9PX Gen2 is designed for reliable, autonomous operation while providing you with notifications and alerts whenever a potential operational or performance issue occurs.

Usually the alarms shown by the control panel do not mean that the output power is affected. Instead, they are preventive alarms intended to alert the user.

- Events are silent status information that are recorded into the Event log. Example = "AC freq in range".
- Alarms are recorded into the Event log and displayed on the LCD status screen with the logo blinking. Some alarms may be announced by a beep every 3 seconds. Example = "Battery low".
- Faults are announced by a continuous beep and red LED, recorded into the Fault log and displayed on the LCD with a specific message box. Example = Out. short circuit.

Use the following troubleshooting chart to determine the UPS alarm condition.

Usually the alarms shown by the product do not mean that the output power is affected. Instead, they are preventive alarms intended to alert the user.

- Some alarms may be announced by a beep in a regular way. Example = "Battery low".
- Faults are announced by a continuous beep and red LED.



Use the following troubleshooting chart to determine the UPS alarm condition.





8.1 Typical alarms and faults

To check the Event log or Fault log:

1. Press any button on the front panel display to activate the menu options.
2. Press the down button to select Event log or Fault log.
3. Scroll through the listed events or faults.

The following table describes typical conditions:

Conditions	Possible cause	Action
Battery mode  LED is On. 1 beep every 10 seconds	A utility failure has occurred and the UPS is in battery mode.	The UPS is powering the equipment with battery power. Prepare your equipment for shutdown.
Battery low  LED is On. 1 beep every 3 seconds	The UPS is in Battery mode and the battery is running low.	This warning is approximate, and the actual time to shutdown may vary significantly. Depending on the UPS load and number of Extended Battery Modules (EBMs), the "Battery Low" warning may occur before the batteries reach 20% capacity.
No battery  LED is On Beep continuous	The batteries are disconnected.	Verify that all batteries are properly connected. If the condition persists, contact your service representative.

Conditions	Possible cause	Action
Battery fault  LED is On. Beep continuous	The battery test is failed due to bad or disconnected batteries.	Verify that all batteries are properly connected. If the condition persists, contact your service representative.
The UPS does not provide the expected backup time.	The batteries need charging or service.	Apply utility power for 48 hours to charge the batteries. If the condition persists, contact your service representative.
Bypass mode  LED is on.	An overload or a fault has occurred, or a command has been received and the UPS is in Bypass mode.	Equipment is powered but not protected by the UPS. Check for one of the following alarms: overtemperature, overload or UPS failure.
Power Overload  LED is On	Power requirements exceed the UPS capacity (greater than 100% of nominal; see "User Settings" for specific output overload ranges).	Remove some of the equipment from the UPS. The UPS continues to operate, but may shut down if the load increases. The alarm resets when the condition becomes inactive.
UPS overtemperature  LED is On Beep continuous	The UPS internal temperature is too high or a fan has failed. At the warning level, the UPS generates the alarm but remains in the current operating state. If the temperature rises another 10°C, the UPS shuts down.	Clear vents and remove any heat sources. Allow the UPS to cool. Ensure the airflow around the UPS is not restricted. Restart the UPS. If the condition continues to persist, contact your service representative.
The UPS does not start	The input source is not connected correctly.	Check the input and battery connections.
	The Remote Power Off (RPO) switch is active or the RPO connector is missing.	If the UPS Status menu displays the "Remote Power Off" notice, deactivate the RPO input.
Input bad wiring / Output bad wiring  LED is On Beep continuous	Input/Output cables are not connected to the correct terminal blocks.	Connect correctly the Input/Output cables.
MBP disconnected	The HotSwap MBP is no more connected to the UPS.	If the HotSwap MBP is connected to the UPS, check that the detection connector is correctly plugged.

8.2 Silencing the alarm

Press the ESC (Escape) button on the front panel display to silence the alarm. Check the alarm condition and perform the applicable action to resolve the condition. If the alarm status changes, the alarm beeps again, overriding the previous alarm silencing.

8.3 Service and support

If you have any question or problem with the UPS, call Eaton or your local service representative in your country / region. Please have the following information ready when you call for service:

- Model number
- Serial number
- Firmware version number
- Date of failure or problem
- Symptoms of failure or problem
- Customer return address and contact information

If repair is required, you will be given a Returned Material Authorization (RMA) number. This number must appear on the outside of the package and on the Bill Of Lading (if applicable). Use the original packaging or request packaging from the Help Desk or distributor. Units damaged in shipment as a result of improper packaging are not covered by warranty. A replacement or repair unit will be shipped freight prepaid for all warrantied units.



For critical applications, immediate replacement may be available. Call the Help Desk for the dealer or distributor nearest you.

9 Specification and technical characteristics

9.1 UPS model list

Description	Catalog Number	Power rating	Configuration
Eaton 9PX 5000i RT3U Netpack G2 Eaton 9PX 5000i RT3U HotSwap Netpack G2	9PX5KIRTG2 9PX5KIRTNBPG2	5000W/5000VA	Rack / Tower
Eaton 9PX 6000i RT3U Netpack G2 Eaton 9PX 6000i RT3U HotSwap Netpack G2	9PX6KIRTG2 9PX6KIRTNBPG2	6000W/6000VA	Rack / Tower
Eaton 9PX 8000i RT4U Netpack G2 Eaton 9PX 8000i RT4U HotSwap Netpack G2	9PX8KIRTG2 9PX8KIRTNBPG2	8000W/8000VA	Rack / Tower
Eaton 9PX 11000i RT4U Netpack G2 Eaton 9PX 11000i RT4U HotSwap Netpack G2	9PX11KIRTG2 9PX11KIRTNBPG2	11000W/11000VA	Rack / Tower

9.2 Extended Battery Module model list

Model	Catalog Number	Configuration	Battery voltage	Use with
Eaton 9PX EBM 180V RT3U G2	9PXEBM180RT3 UG2	Rack / Tower	180Vdc	9PX5KIRTG2, 9PX6KIRTG2,
Eaton 9PX EBM 240V RT3U G2	9PXEBM240RT3 UG2	Rack / Tower	240Vdc	9PX8KIRTG2, 9PX11KIRTG2,

Function block Diagram of 5~6K models

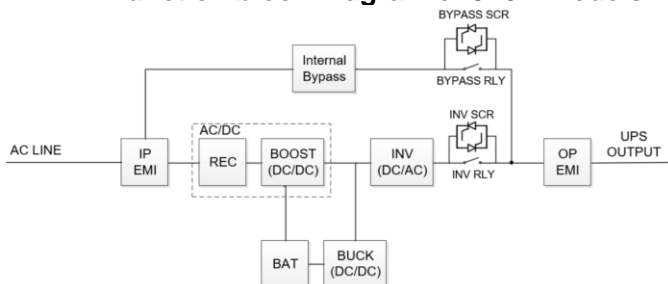

Function block Diagram of 8~11K models

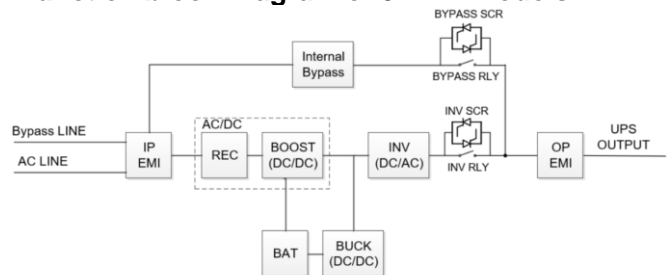

9.3 Electrical input

Default frequency	50Hz
Nominal frequency	50/60Hz
Frequency range	40-70Hz
Protective class	Protective class I

Catalog Number	Default input (Voltage/Current)	Input nominal voltages	Input voltage window
9PX5KIRTG2 9PX5KIRTNBPG2 9SX5KIRT3UG2 9PX5KIRTG2	230V/23A	200V, 208V, 220V, 230V , 240V	at 100% load: 176-276V at ≤40% load: 100-276V
9PX6KIRTG2 9PX6KIRTNBPG2 9SX6KIRT3UG2 9PX6KIRTG2	230V/27.6A		
9PX8KIRTG2 9PX8KIRTNBPG2	230V/36.5A		
9PX11KIRTG2 9PX11KIRTNBPG2	230V/50.2A		

9.4 Electrical input connections

Catalog Number	Input connection	Input cable
9PX5KIRTG2 9PX5KIRTNBPG2	Hardwired	Not provided
9PX6KIRTG2 9PX6KIRTNBPG2		
9PX8KIRTG2 9PX8KIRTNBPG2	Hardwired	Not provided
9PX11KIRTG2 9PX11KIRTNBPG2		

9.5 Electrical output

All models	Normal mode	High Efficiency mode	Battery mode
Voltage regulation	±1%		±1%
Efficiency	5000/6000 VA: Up to 96.7% 8000/11000 VA: Up to 97.2%	5000/6000 VA: Up to 98.9% 8000/11000 VA: Up to 99.5%	5000/6000 VA: Up to 95% 8000/11000 VA: Up to 96.1%
Frequency regulation	Sync with line ±5% of nominal line frequency (outside this range: ±0.5% of auto-selected nominal frequency)		±0.5% of auto-selected nominal frequency
Nominal output	200/208/220/230/240V		
Nominal Frequency	50Hz or 60Hz, autosensing or configurable as a frequency converter		
Output overload	[102-125%*] 10 mins [125-150%] 30 sec >150% 0.5s		[102-130%] 5mins >130% 100ms
Short circuit current limitation	Depend on the external fuse or breaker in the upstream of UPS 5000/6000 VA : 90A 8000 VA : 120A 11000 VA : 150A < 5 cycles		
Voltage waveform	sin wave		
Harmonic distortion	< 1% THDV on linear load < 5% THDV on non-linear load		
Power Factor	up to 1		
Load crest ratio	3:1		

9.6 Electrical output connection

Catalog Number	Output connection	Output cable
9PX5KIRTG2 9PX5KIRTNBPG2 9PX6KIRTG2 9PX6KIRTNBPG2	Hardwired (1) IEC 16A Primary group (1) IEC 16A + (4) IEC 10A Group 1 (1) IEC 16A + (4) IEC 10A Group 2	(2) IEC 10A 1.2m
9PX8KIRTG2 9PX8KIRTNBPG2 9PX11KIRTG2 9PX11KIRTNBPG2	Hardwired (2) IEC 16A Primary group (1) IEC 16A + (4) IEC 10A Group 1 (1) IEC 16A + (4) IEC 10A Group 2	(2) IEC 10A 1.2m

9.7 Battery

	Internal batteries	EBM
Specifications	5000/6000VA: 180Vdc – 1x15x12V, 5Ah 8000/11000VA: 240Vdc - 1x20x12V, 9Ah	9PXEBM180RT3UG2: 180Vdc - 2x 15x12V, 2x5Ah=10Ah 9PXEBM240RT3UG2: 240Vdc – 1x20x12V, 9Ah
Type	Sealed, maintenance-free, valve-regulated, lead-acid, with minimum 3-5 year float service life at 25°C (77°F).	
Monitoring	Advanced Battery Management for earlier failure detection and warning (ABM+)	
EBM battery cable length	180V DC : 330mm 240V DC : 400mm	

9.8 Environmental and safety

Standards	IEC/EN 62040-1 Safety IEC/EN 62040-2 Electromagnetic Compatibility EMC IEC/EN 62040-3 Performance FCC part 15 Class A UL 1778ENERGY STAR Program Requirements for uninterruptible Power Supplies (UPSs) Version 2.0
EMC (Emissions)	CISPR32 Class A FCC part 15 Class A IEC/EN 62040-2 C1 IEC/EN 61000-3-2 or IEC/EN 61000-3-12 Harmonics IEC/EN 61000-3-3 or IEC/EN 61000-3-11 Flickers
EMC (Immunity)	IEC 61000-4-2, (ESD): 8 kV Contact Discharge / 15 kV Air Discharge IEC 61000-4-3, (Radiated field): 10 V/m IEC 61000-4-4, (EFT): 4 kV Power Port / 2 kV Network Port IEC 61000-4-5, (Surges): 2 kV Differential Mode / 4 kV Common Mode / 1 kV Network Port IEC 61000-4-6, (Electromagnetic field): 10 V IEC 61000-4-8, (Conducted magnetic field): 30 A/m IEC 61000-4-11, (Voltage Dips) Class 2 IEC 61000-4-12, (Ring Wave): 2 kV Differential Mode / 2kV Common Mode
UPS enclosure IP rating	IP20
Earthing system	This UPS can be connected to TN, TT, IT electrical supply system, same system is supplied to the load.
Overvoltage Category	Category II
Pollution degree	PD2
Operating temperature	0 to 40 °C (32 to 104 °F)
Storage temperature	-15 to 40°C (5 to 104 °F) with battery -25 to 55°C (-13 to 131 °F) without battery

Transit temperature	-25°C to 55°C (-13 °F to 131 °F)	
Relative humidity	0 to 95 % (without condensation)	
Operating altitude	Up to 3,000 meters (9,842ft) above sea level (without derating).	
Transit altitude	Up to 10,000 meters (32,808 ft) above sea level	
Audible noise	Line mode (load <72%, T<30°C) : 11000/8000 VA < 36 dB 6000/5000 VA < 38 dB	Batt. Mode (T<30°C) : 11000/8000 VA < 59 dB 6000/5000 VA < 49 dB

Name and content of hazardous substances in products

部件名称 Component name	有害物质 Hazardous substance					
	铅 (Pb) Lead (Pb)	汞 (Hg) Mercury (Hg)	镉 (Cd) Cadmium (Cd)	六价铬 (Cr(VI)) Hexavalent chromium (Cr (VI))	多溴联苯 (PBB) Polybrominated biphenyls (PBB)	多溴二苯醚 (PBDE) Polybrominated diphenyl ethers (PBDE)
电池类 Battery	X	○	○	○	○	○
印刷电路组件 PCBA	X	○	○	○	○	○
电源线插座端子 Wire terminal	X	○	○	○	○	○
箱体五金类 Hardware	X	○	○	○	○	○
开关 / 断路器类 Switch, breaker, etc.	○	○	○	○	○	○

本表格依据 SJ/T 11364 的规定编制。

○：表示该有害物质在该部件所有均质材料中的含量均在GB/T 26572规定的限量要求以下。

X：表示该有害物质至少在该部件的某一均质材料中的含量超出GB/T 26572规定的限量要求。

环保使用期限的免责条款：环保使用期限规定的具体期限仅为符合中华人民共和国的相应的法律规定，并非代表我司向客户提供保证或负有任何义务。环保使用期限中假定客户按照操作手册在正常情况下使用本产品。

对于本产品中配备的某些组合件（例如，装有电池的组合件）的环保使用期限，可能低于本产品的环保使用期限。

This table was developed according to the provisions of SJ/T 11364.

O: The content of such hazardous substance in all homogeneous materials of such component is below the limit required by GB/T 26572

X: the content of such hazardous substance in a certain homogeneous material of such component is beyond the limit required by GB/T 26572

Environmental Protection Use Period (EPUP) Disclaimer: The number provided as the EPUP is provided solely to comply with applicable laws of the People's Republic of China. It does not create any warranties or liabilities on behalf of our company to customers. The EPUP assumes that the product will be used under normal conditions in accordance with the operating manual. Certain assemblies inside this product (for example, assemblies that contain a battery) may have an EPUP which is lower than the EPUP on this product.



本产品的环保使用期限为20年

10 Glossary

Backup time	Time during which the load can be supplied by the UPS operating on battery power.
Low-battery warning	This is a battery-voltage level indicating that battery power is low and that the user must take action before the UPS shuts down.
Load	Devices or equipment connected to the UPS output.
Normal mode(double conversion)	The normal UPS operating mode in which the AC source supplies the UPS which, in turn, provides AC power to the connected loads. (after electronic double conversion).
Normal AC source	Normal source of power for the UPS.
OVL	Overload. When the load exceeds 100% of the maximum load of the UPS.
UPS	Uninterruptible Power System.
Relay contacts	Contacts supplying information to the user in the form of signals.
Bypass AC source	Source supplying the bypass line. The equipment can be transferred to the by-pass line if an overload occurs on the UPS output, for maintenance or in the event of a malfunction.
EBM	Extended Battery Module
Frequency converter	Operating mode used to convert the AC power frequency between the UPS input and output (50Hz -> 60Hz or 60Hz -> 50Hz).
HE Mode	Operating mode by which the load is supplied directly by the AC source if it is within the tolerances defined by the user. This mode reduces the consumption of electrical power.