

DP3-VA VOLT / CURRENT Indicator (24x48)

Miniature Indicator(24x48mm)



DESCRIPTION

DP3-VA Voltage/Current Indicator has been designed in miniature size(24 x 48mm), and provides high accuracy measurement, display and communication of 0~300V or 0~20mA for DC/AC(average).

They also have the option of 2 Relay outputs, 1 External Control Input, 1 Analogue output or 1 RS485(Modbus RTU Mode) interface with versatile functions such as control, alarm, re-transmission or communication.

FEATURE

- Measuring Voltage 0~300V or Current 0~20mA for DC / AC(average)
- 2 relay can be programmed individual to be a Hi / Lo / Hi Latch / Lo Latch energized with Start Delay / Hysteresis / Energized & De-energized Delay functions, or to be a remote control.
- Analogue output or RS 485 communication port options available
- 1 external control input can be programmed to be Relative PV(Tare) / PV Hold / DI (remote monitoring) / Reset for Maximum or Minimum Hold / Reset for Relay Energized Latch....
- CE Approved

APPLICATIONS

- Testing Equipments for Volt/Current Measuring, Alarm, Control and Communication with PC/PLC
 - ☑ Flexible 1 DI functions such as Maximum/Minimum hold, PV hold and Relative PV.
 - ☑ 2 Relay functions such as Hi / Lo with on and off delay time from 0.0(s)~ 9(m):59.9(s)
- MCC panel, Machinery, Switch gear... for Voltage or Current Measuring, Alarm and Remote I/O with PC/PLC
 - ☑ Fantastic 2 Relay functions such as Hi / Lo / Hi latch / Lo latch / DO(Remote control by PC/PLC).
 - ☑ Flexible 1 DI functions such as Reset for Relay energized and Remote monitoring by PC/PLC.

ORDERING INFORMATION

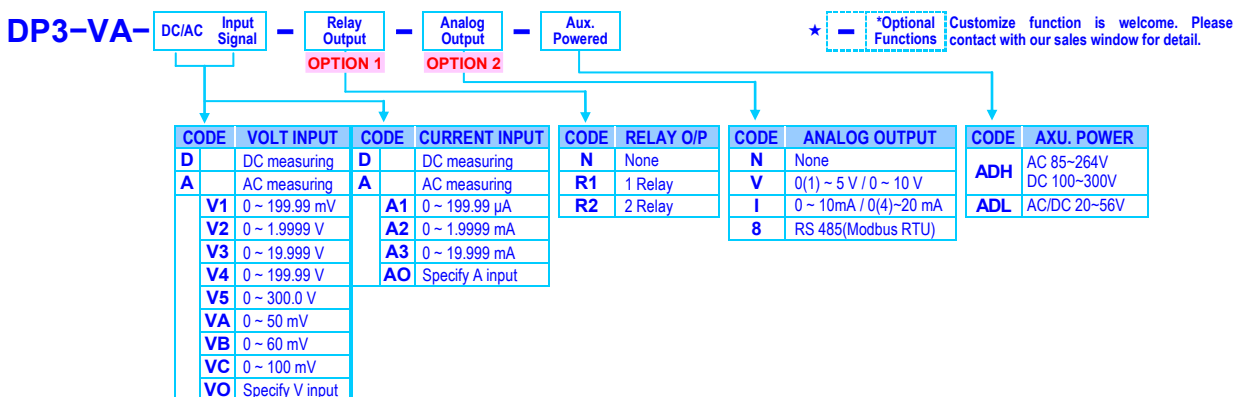

TECHNICAL SPECIFICATIONS

Input Signal

Measuring Range DC / AC(average)	Input Impedance	Measuring Range DC / AC(average)	Input Impedance
Voltage	0~50/~100 mV	Current	0~199.99 μ A
	0~199.99 mV		0~1.9999 mA
	0~1.9999 V		0~19.999 mA
	0~19.999 V		
	0~199.99 V		
0~300.0 V			

Input range:

Input High and Low programmable
ahi: Settable range: 0.00~100.00% of input range
allo: Settable range: 0.00~100.00% of input range

Max. Input over capability:

Voltage: 2 x rated continuous;
 4 x rated for 2 seconds;
Current: 3 x rated continuous;
 10 x rated for 10 seconds;
 50 x rated for 1 second(for 20mA input type)

Calibration:

Digital calibration by front key

A/D converter:

16 bits resolution

Accuracy:

DC: $\pm 0.04\%$ of FS $\pm 1C$
 AC: $\pm 0.1\%$ of FS $\pm 1C$

Sampling rate:

15 cycles/sec

Response time:

≤ 100 msec.(when the avg = "1") in standard

Display & Functions

LED:

Numeric: 5 digits, 0.4"(10.0mm)H red high-brightness LED
 Relay output indication: 2 square red LED
 RS 485 communication: 1 square orange LED
 E.C.I. function indication: 1 square green LED



University
 UNIVERSITY PATON INSTRUMENTS - THE EDUCATED CHOICE



Display range:	-19999~29999;
Scaling function:	IOsc: Low Scale; Settable range: -19999~+29999 hIsc: High Scale; Settable range: -19999~+29999 Programmable from 0 / 0.0 / 0.00 / 0.000 / 0.0000
Decimal point:	
Over range indication:	ovfl , when input is over 20% of input range Hi
Under range indication:	-ovfl , when input is under -20% of input range Lo
Max / Mini recording:	Maximum and Minimum value storage during power on.
Display functions:	PV / Max(Mini) Hold / RS 485 Programmable
Front key functions:	Up key can be set to be a function as ECI.
Low cut:	Settable range: -19999~29999 counts
Digital fine adjust:	pVzro: Settable range: -19999~+29999 pVspn: Settable range: -19999~+29999

Reading Stable Function

Average:	[avg]: Settable range: 1~99 times
Moving average:	[Mavg]: Settable range: 1(Non)/~10 times
Digital filter:	[Dflt]: Settable range: 0(Non)/1~99 times

Control Functions(option)

Set-points:	Two set-points, setting range : -19999~+29999
Control relay:	2 Relays FORM-C, 1A/230Vac, 3A/115V
Relay energized mode:	Energized levels compare with set-points: Hi / Lo / Hi.HLd / Lo.HLd; programmable DO function: Energized by RS485 command of master.
Energized functions:	Start delay / Energized & De-energized delay / Hysteresis / Energized Latch Start band(Minimum level for Energizing): 0~999counts Start delay time: 0:00.0~9(Minutes):59.9(Second) Energized delay time: 0:00.0~9(Minutes):59.9(Second) De-energized delay time: 0:00.0~9(Minutes):59.9(Second) Hysteresis: 0~5000 counts

External Control Inputs(ECI)

Input mode:	1 ECI points, Contact or open collect input, Level trigger
Functions:	Relative PV(Tare) / PV Hold / Reset for Max or Mini. Hold / DI / Reset for Relay Energized latch
Debouncing time:	Settable range 5 ~255 x (8mseconds)

Analogue output(option)

Accuracy:	$\pm 0.1\%$ of F.S.; 16 bits DA converter
Ripple:	$\pm 0.1\%$ of F.S.
Response time:	≤ 100 m-sec. (10~90% of input)
Isolation:	AC 1.5 KV between input and output
Output range:	Specify either Voltage or Current output in ordering Voltage: 0~5V / 0~10V / 1~5V programmable Current: 0~10mA / 0~20mA / 4~20mA programmable Voltage: 0~10V: $\geq 1000\Omega$; Current: 4(0)~20mA: $\leq 600\Omega$ max
Output capability:	
Functions:	[a0hs] (output range high): Settable range: -19999~29999 [a0ls] (output range Low): Settable range: -19999~29999 [a0lmt] (output High Limit): 0.00~110.00% of output High [a0zro] Settable range: -38011~+27524 [a0spn]: Settable range: -38011~+27524
Digital fine adjust:	

RS 485 Communication(option)

Protocol:	Modbus RTU mode
Baud rate:	1200/2400/4800/9600/19200/38400 programmable
Data bits:	8 bits
Parity:	Even, odd or none (with 1 or 2 stop bit) programmable
Address:	1 ~ 255 programmable
Remote display:	to show the value from RS485 command of master
Distance:	1200M
Terminate resistor:	150 Ω at last unit.

Electrical Safety

Dielectric strength:	AC 1.5 KV for 1 min, Between Power / Input / Output / Case
Insulation resistance:	≥ 100 M ohm at 500Vdc, Between Power / Input / Output
Isolation:	Between Power / Input / Relay / Analogue / RS485 / E.C.I.
EMC:	EN 55011:2002; EN 61326:2003
Safety(LVD):	EN 61010-1:2001

Environmental

Operating temp.:	0~60 °C
Operating humidity:	20~95 %RH, Non-condensing
Temp. coefficient:	≤ 100 PPM/°C
Storage temp.:	-10~70 °C
Enclosure:	Front panel: IEC 529 (IP52); Housing: IP20

Mechanical

Dimensions:	48mm(W) x 24mm(H) x 102mm(D)
Panel cutout:	44mm(W) x 22.5mm(H)
Case material:	ABS fire-resistance (UL 94V-0)
Mounting:	Panel flush mounting
Terminal block:	Plastic NYLON 66 (UL 94V-0) 5A 300Vac, M2.0, 0.5~1.3mm ² (22~16AWG)
Weight:	About 110g

Power

Power supply:	AC 85~264V / DC 100~300V, DC 20~56V
Power consumption:	4.5VA max.
Back up memory:	By EEPROM

FRONT PANEL

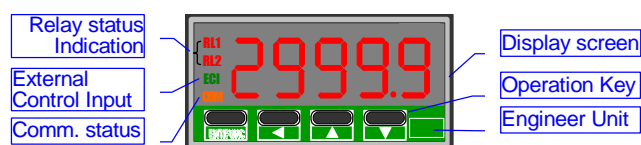

DIMENSIONS

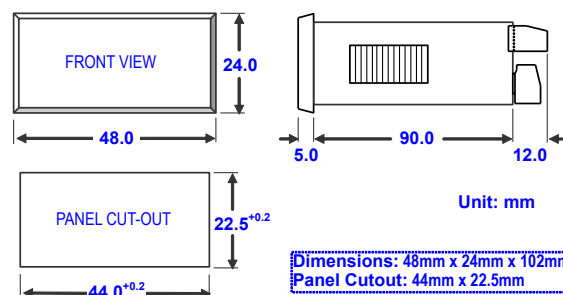

INSTALLATION

The meter should be installed in a location that does not exceed the maximum operating temperature and provides good air circulation.

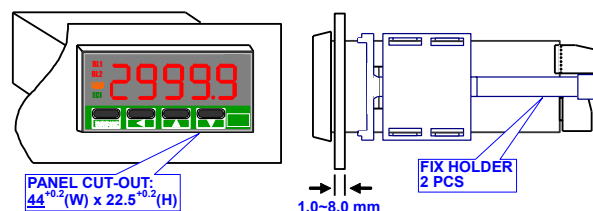

CONNECTION DIAGRAM

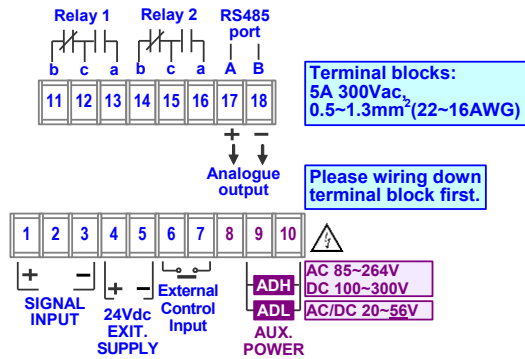

Please check the voltage of power supplied first, and then connect to the specified terminals. It is recommended that power supplied to the meter be protected by a fuse or circuit breaker.

Power Supply

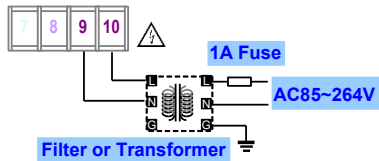

Voltage Input connection

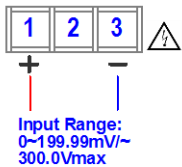

Remark:
PT can not short in secondary.

Current Input connection

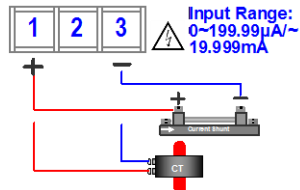

Remark:
CT can not open in secondary.

RS485 Communication Port

