

EFL2503-HV-12

HIGH CAPACITY ELECTRIC COUNTERBALANCED FORKLIFT 25T

📏 25000 kg 📏 5000 mm 🔋 618.24 V Li-Ion



With its 618V high-voltage Li-ion system and robust 135 kW PMSM motor, the EFL2503-HV sets a new standard in the high-capacity forklift segment. Capable of lifting 25,000 kg at a 1,200 mm load center, it combines diesel-like power with electric precision. Designed for maximum uptime, the truck features advanced thermal management, high-grade hydraulics, and a full AC cabin for operator comfort and safety.

SPECIFICATION	REF	UNIT	VALUE
Battery type			Li-Ion
Battery nominal capacity K5		Ah	618.24/456
Battery voltage		V	618.24
Rated capacity	Q	kg	25000
Load centre distance	c	mm	1200
Service weight		kg	38700
Height, mast lowered	h ₁	mm	3950
Lift	h ₃	mm	4000
Height, mast extended	h ₄	mm	5890
Overall length	l ₁	mm	8860
Overall width	b ₁ /b ₂	mm	3080
Length to face of forks	l ₂	mm	6420
Fork dimensions	s/e/l	mm	110×250×2400
Turning radius	Wa	mm	6350
Manufacturer			EP
Model designation			EFL2503-HV-12

Features

High Performance: High speed and high gradeability

High-voltage Li-ion batteries enable more power delivery to motors, improving acceleration and travel speeds for high-capacity trucks. PMSMs complement this with rapid response times, swiftly reaching required speeds and torques. This combination of PMSM and high voltage can provide stable and strong power output, which further gives high-capacity trucks excellent climbing capabilities ensuring that the forklift can cope with various applications with ease.

The high-voltage model offers a 1.5-2 times performance improvement over the low-voltage model. Taking the 10-ton model as an example:

100% improvement in travel speed for high voltage models in laden and unladen conditions.

The high-voltage model demonstrates a 45% faster lifting speed.

100% improvement in gradeability when unladen, 45% improvement when laden for high voltage models.

Energy Efficiency: extended runtime and fast charging

High-voltage Li-ion batteries have high energy density and can store more electrical energy within a compact volume. High-voltage systems consume less energy and provide longer battery running time comparing low-voltage systems. Notably, these high-voltage Li-ion batteries boast an impressive cycle life of up to 4000 cycles, ensuring long-term durability and minimizing the need for battery replacements.

The PMSMs incorporate advanced control technology to optimize motor efficiency. Unlike traditional AC motors, PMSMs have higher energy conversion efficiency and reduce energy waste. This means that high-capacity trucks can work continuously for prolonged hours at lower costs.

Equipped with fast charging capabilities, high-capacity trucks offer a remarkable charging experience. The high-voltage models are compatible with vehicle-grade charging stations and support 1C charging rating, allowing them to be fully charged in as fast as 1-1.2 hours. This minimizes downtime and maximizes productivity, making it ideal for multi-shift operations

Lithium batteries present considerably lower charging costs than fuel expenses. The integration of high-voltage and PMSM technology achieves up to 15% greater electricity savings versus traditional lithium and AC technology configurations. This significantly reduces long-term energy consumption costs.



Safety Assured: Battery, motor protection, monitoring and mast buffering

Both high-voltage lithium batteries and PMSM employ multiple protective measures to ensure safe operations including overcharge protection, over-temperature monitoring, short-circuit protection, etc. minimizing the risk of potential hazards and maximizing operational safety.

The central controlling module- VCU (Vehicle Control Unit) extends the safety of the high-voltage forklifts. VCU provides precise control and real-time monitoring of critical parameters to ensure the truck operates within safe limits.

It also features turn speed control, which adjusts the forklift's speed based on the turning angle, ensuring stability during turns. An over-speed alarm alerts the operator if the forklift exceeds the safe speed limit.*

The high-capacity forklift mast is equipped with a hydraulic buffering system that ensures smooth lifting and lowering of loads. With controlled deceleration, the fork movement is smooth with no abrupt stops that could damage the load or cause operator discomfort. This feature enhances operational safety and prolongs the lifespan of the mast components.



Smart and reliable strategy for thermal management

The high-capacity trucks utilize three distinct cooling systems to ensure optimal performance and reliability. Specifically, two water cooling systems are employed for the motor and the battery, while an oil cooling system is dedicated to the hydraulics system.

The water cooling systems provide superior cooling performance, preventing the truck from overheating even under the most demanding conditions or in the heat of summer. Water's higher heat transfer capacity compared to air allows it to dissipate heat more efficiently from critical components like the motor and battery. This efficient heat dissipation helps maintain the battery temperature around 30~35 °C , protecting these vital components from overheating and potential damage or failure. Consequently, this enhances the overall reliability and longevity of the high-capacity trucks.

Additionally, water cooling systems typically operate with less noise compared to air cooling systems that rely on high-speed fans. This noise reduction is particularly beneficial in applications where a quieter operation is desirable, such as in urban areas or indoor facilities.

The oil cooling system, on the other hand, is used for the hydraulics system. This system ensures that the hydraulic components remain within optimal temperature ranges, thereby maintaining their efficiency and preventing overheating. By effectively managing the temperature of the hydraulics system, the oil cooling system contributes to the smooth and reliable operation of the truck's hydraulic functions.

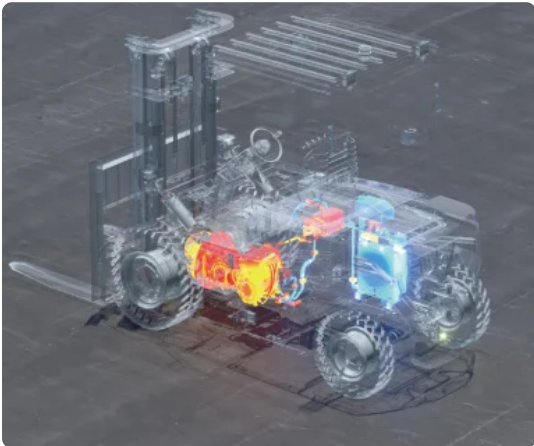

Low maintenance: Longer battery life span

Operating at a higher voltage allows the battery to be designed with fewer individual cells. With fewer components and a simpler design, the risk of battery failure is lowered.

Thanks to advanced BMS (Battery Management System) which helps to regulate and monitor high-voltage battery, these batteries tend to have a longer life than low-voltage lithium batteries, reducing the need of battery replacement.

The brushless, simple rotor design of PMSM eliminates mechanical wear from brushes and commutators. This durable, low-friction construction requires minimal periodic maintenance, reducing associated labor costs and downtime.

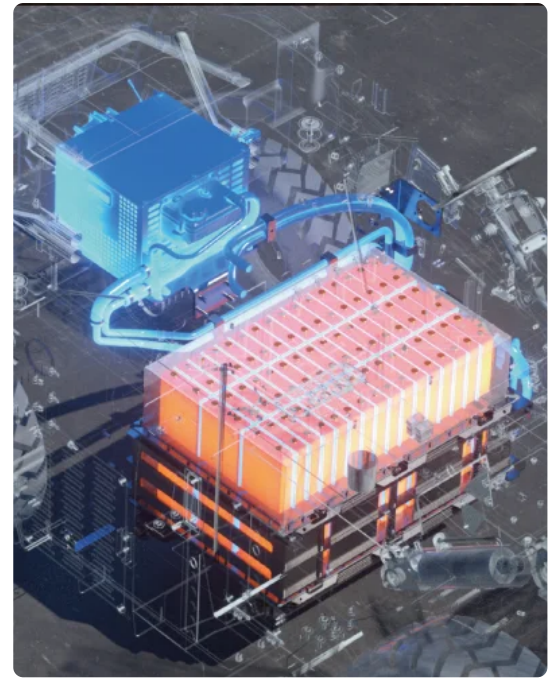

Sustainability : Zero emissions for cleaner environment

As fully electric trucks powered by lithium-ion batteries, these forklifts produce zero emissions during operation, eliminating exposure to toxic fumes like carbon monoxide and nitrogen oxides. Unlike lead-acid batteries which can leak corrosive acid, lithium-ion batteries do not risk hazardous spills. The high-capacity li-ion trucks contribute to a cleaner and safer indoor working environment without compromising handling capabilities.

Strong adaptability adaptable to harsh outdoor weather conditions

Experience uninterrupted productivity through rain, puddles, and damp conditions with the overall IPX4 rating. Plus an exceptional IP67 rating for high-voltage components. Engineered to withstand harsh temperature, high-capacity trucks offer an ambient temperature range of -20 °C ~40 °C allowing them to perform no matter climate.

Battery heating when charging comes as a standard function for high capacity models, which is activated when the surrounding temperature is below zero to always offer an optimal temperature range for efficient and safe charging even in cold weather conditions.



The dual front wheels is a standard configuration on several models offering a wider base of support, which greatly improves the forklift's stability. Considering the capacity loads of the high-capacity trucks, the weight of the load is more evenly distributed across a larger surface area. The increased ground contact area provided by the dual wheels enhances traction. This is particularly beneficial in environments where the floor may be slippery or uneven while operating outdoors, ensuring that the forklift can maintain a firm grip and operate safely. This not only helps in maintaining balance but also minimizes the stress on individual tires, extending the lifespan of the tires.

Great support for clients' investment: After-sales Service

Remote/Online Services:

Telematics technology enables remote monitoring of battery conditions, performance status, and other critical parameters for forklifts. Additionally, production, technical, and after-sales experts are available around the clock to provide prompt and comprehensive solutions for any maintenance issues through virtual support.

Physical Services:

Comprehensive manuals and supporting documents are provided for all forklift models. In case of breakdowns or replacements, spare parts are swiftly delivered to the clients' locations by global subsidiaries or domestic inventory, minimizing operational disruptions caused by equipment downtime.

VDI Chart

SPECIFICATION	REF	UNIT	VALUE
1.1	Manufacturer		EP

SPECIFICATION		REF	UNIT	VALUE
1.2	Model designation			EFL2503-HV-12
1.3	Drive			Electric
1.4	Operator type			Seated
1.5	Rated capacity	Q	kg	25000
1.6	Load centre distance	c	mm	1200
1.8	Load distance, centre of drive axle to fork	x	mm	1130
1.9	Wheelbase	y	mm	4300
2.1	Service weight		kg	38700
2.2	Axle loading, laden front/rear		kg	57800/5900
2.3	Axle loading, unladen front/rear		kg	18900/19800
3.1	Tyres			Pneumatic
3.2	Tyre size, front		mm	14.00-24-28PR
3.3	Tyre size, rear		mm	14.00-24-28PR
3.5	Wheels, number front/rear (x=drive wheels)			4×/2
3.6	Tread width, front	b ₁₀	mm	2200
3.7	Tread width, rear	b ₁₁	mm	2460
4.1	Tilt of mast/fork carriage forward/backward		°	6/10
4.2	Height, mast lowered	h ₁	mm	3950
4.3	Free lift	h ₂	mm	125
4.4	Lift	h ₃	mm	4000
4.5	Height, mast extended	h ₄	mm	5890
4.7	Height of overhead guard (cabin)		mm	3380
4.8	Seat height relating to SIP/stand height		mm	2465
4.12	Coupling height		mm	390
4.19	Overall length	l ₁	mm	8860
4.20	Length to face of forks	l ₂	mm	6420
4.21	Overall width	b ₁ /b ₂	mm	3080
4.22	Fork dimensions	s/e/l	mm	110×250×2400
4.23	Fork carriage ISO 2328, class/type A, B			-
4.24	Fork carriage width		mm	3080
4.31	Ground clearance, laden, below mast		mm	220
4.32	Ground clearance, centre of wheelbase	m ₂	mm	370
4.34.1	Aisle width for pallets 1000×1200 crossways	Ast	mm	10120
4.34.2	Aisle width for pallets 800 × 1200 lengthways	Ast	mm	10120

SPECIFICATION		REF	UNIT	VALUE
4.35	Turning radius	Wa	mm	6350
5.1	Travel speed, laden/unladen		km/h	22/22
5.2	Lift speed, laden/unladen		m/s	0.3/0.35
5.3	Lowering speed, laden/unladen		m/s	0.48/0.4
5.5	Drawbar pull, laden/unladen			140000/140000
5.6	Max. drawbar pull, laden/unladen			160000/160000
5.8	Max. gradeability, laden/unladen		%	20/30
5.10	Service brake			Mechanical/Hydraulic
5.11	Parking brake			Mechanical/Hydraulic
6.1	Drive motor rating S2 60 min		kW	135
6.2	Lift motor rating at S3 15%		kW	90
6.4	Battery nominal capacity K5		Ah	618.24/456
6.4	Battery voltage		V	618.24
6.4.1	Battery type			Li-Ion
6.5	Battery weight		kg	1864
6.6	Energy consumption according to DIN EN 16796		kWh/h	26 ¹⁾
6.7	Turnover output according to VDI 2198			/
6.8	Turnover efficiency according to VDI 2198			/
8.1	Type of drive unit			PMSM
10.1	Operating pressure for attachments		bar	180
10.2	Oil volume for attachments		ℓ/min	80
10.5	Steering design			Hydraulic
10.7	Sound pressure level at the driver's seat		dB(A)	< 75
15.1	Charger output current		A	115

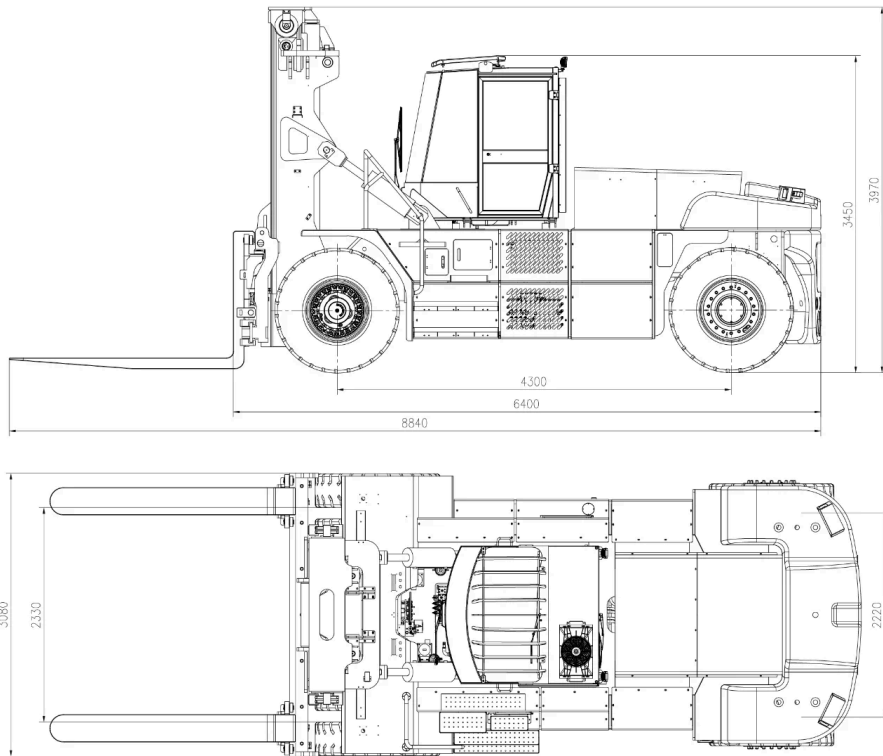

RATED CAPACITIES AND LOAD CENTERS GRAPH

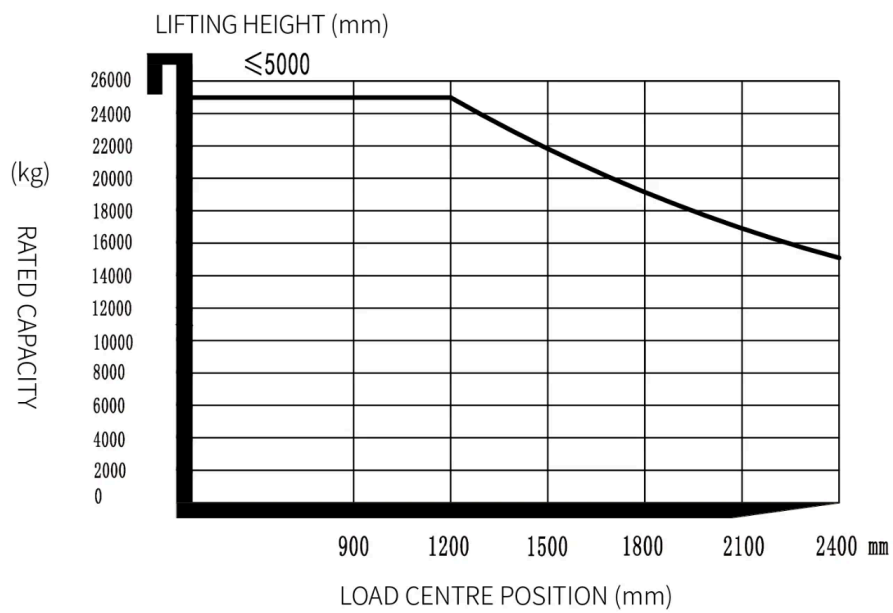

Mast Options

MAST TYPE	LIFT HEIGHT (H3, MM)	MAST LOWERED HEIGHT (H1, MM)	MAST EXTENDED HEIGHT, NO BACKREST (H4, MM)	FREE LIFT HEIGHT, NO BACKREST (H2, MM)	FORWARD TILT (A, DEG)	BACKWARD TILT (B, MM)	LOAD DISTANCE (X, MM)
2-Standard Mast	3600	3750	5490	125	6	10	1130
2-Standard Mast	4000	3950	5890	125	6	10	1130
2-Standard Mast	4500	4200	6390	125	6	10	1130
2-Standard Mast	5000	4450	6890	125	6	10	1130

Options

ITEM	OPTIONS (optional items marked in yellow)
Fork dimension	12500*1200, 5A, 250*110*2440 12500*1200, 5A, 300*120*2440
Fork lowered height	125
Fork carriage width option	3080
Load wheel type	Double
Load wheel material	Rubber
Drive wheel material	Rubber
Front wheel type	Double
Front wheel material	Pneumatic Solid
Rear wheel material	Pneumatic Solid
Battery capacity	614.4V/460Ah
Charger	200V-750V/60KW External (national standard) 300V-1000V/80KW External (national standard) 200V-750V/20KW External (European standard)
Battery display indicator (BDI)	With time
Seat type	Suspension + safety belt logic switch
Attachments	Adjustable fork
Safe hook	No
Traction pin	Yes and not customized
Anti-static chain	No
Handle head type	One-handed big handle head

ITEM	OPTIONS (optional items marked in yellow)
Castor wheels	No
Water auto-filling system	No
Front lamp	LED
Rear lamp	LED
Warning lamp	Yes and not customized
Steering lamp	LED
Blue lamp	Yes and not customized
Area warning lamp	Yes and not customized
Rearview mirror	Yes and not customized
Buzzer	Yes and not customized
Camera	Yes and not customized
Fire extinguisher	Yes and not customized
Vertical handler working	No
OPS system	Yes and not customized
Guide wheel	No
USB interface	Yes and not customized
Telematics	No Yes and not customized
Charging interlock-UK standard	Yes and not customized
Battery side pull function	No
Cold storage	No
Cabin	Fully enclosed cabin;front, rear and top wipers; With electric fan;Heating and cooling air conditioning system
Proportional lift system	Yes and not customized
Forks tilt forward and backward	Yes and not customized
Overhead guard	Yes and not customized
Battery side pull attachment	No
Turn speed control	Yes
Heating system during lithium battery charging	Yes