



# EFL1203-HV-6

## HIGH CAPACITY ELECTRIC COUNTERBALANCED FORKLIFT 12T

 12000 kg  7000 mm  309 V Li-Ion



The EFL1203-HV is ideal for heavy industries such as steel, construction materials, mining, and port logistics. Built for lifting loads up to 12 tons with a 600 mm load center, it performs seamlessly on rough terrain and in outdoor environments. With a high ground clearance, robust IC-style chassis, and a choice of masts up to 7,000 mm lift height, it supports intensive operations with precision and stability. Optional full cabins, telematics, and specialized attachments such as fork positioners and sidershifters make it adaptable to various industrial applications.

SPECIFICATION	REF	UNIT	VALUE
Battery type			Li-Ion
Battery nominal capacity K5		Ah	304
Battery voltage		V	309
Rated capacity	Q	kg	12000
Load centre distance	c	mm	600
Service weight		kg	15500
Height, mast lowered	$h_1$	mm	3175
Lift	$h_3$	mm	3000
Height, mast extended	$h_4$	mm	4645
Overall length	$l_1$	mm	5832
Overall width	$b_1/b_2$	mm	2350
Length to face of forks	$l_2$	mm	4462
Fork dimensions	s/e/l	mm	88x175x1370
Turning radius	Wa	mm	4290
Manufacturer			EP
Model designation			EFL1203-HV-6

# Features

---

## High Performance: High speed and high gradeability

High-voltage Li-ion batteries enable more power delivery to motors, improving acceleration and travel speeds for high-capacity trucks. PMSMs complement this with rapid response times, swiftly reaching required speeds and torques. This combination of PMSM and high voltage can provide stable and strong power output, which further gives high-capacity trucks excellent climbing capabilities ensuring that the forklift can cope with various applications with ease.

The high-voltage model offers a 1.5-2 times performance improvement over the low-voltage model. Taking the 10-ton model as an example:

100% improvement in travel speed for high voltage models in laden and unladen conditions.

The high-voltage model demonstrates a 45% faster lifting speed.

100% improvement in gradeability when unladen, 45% improvement when laden for high voltage models.

## Energy Efficiency: extended runtime and fast charging

High-voltage Li-ion batteries have high energy density and can store more electrical energy within a compact volume. High-voltage systems consume less energy and provide longer battery running time comparing low-voltage systems. Notably, these high-voltage Li-ion batteries boast an impressive cycle life of up to 4000 cycles, ensuring long-term durability and minimizing the need for battery replacements.

The PMSMs incorporate advanced control technology to optimize motor efficiency. Unlike traditional AC motors, PMSMs have higher energy conversion efficiency and reduce energy waste. This means that high-capacity trucks can work continuously for prolonged hours at lower costs.

Equipped with fast charging capabilities, high-capacity trucks offer a remarkable charging experience. The high-voltage models are compatible with vehicle-grade charging stations and support 1C charging rating, allowing them to be fully charged in as fast as 1-1.2 hours. This minimizes downtime and maximizes productivity, making it ideal for multi-shift operations

Lithium batteries present considerably lower charging costs than fuel expenses. The integration of high-voltage and PMSM technology achieves up to 15% greater electricity savings versus traditional lithium and AC technology configurations. This significantly reduces long-term energy consumption costs.



## Safety Assured: Battery, motor protection, monitoring and mast buffering

Both high-voltage lithium batteries and PMSM employ multiple protective measures to ensure safe operations including overcharge protection, over-temperature monitoring, short-circuit protection, etc. minimizing the risk of potential hazards and maximizing operational safety.

The central controlling module- VCU (Vehicle Control Unit) extends the safety of the high-voltage forklifts. VCU provides precise control and real-time monitoring of critical parameters to ensure the truck operates within safe limits.

It also features turn speed control, which adjusts the forklift's speed based on the turning angle, ensuring stability during turns. An over-speed alarm alerts the operator if the forklift exceeds the safe speed limit.\*

The high-capacity forklift mast is equipped with a hydraulic buffering system that ensures smooth lifting and lowering of loads. With controlled deceleration, the fork movement is smooth with no abrupt stops that could damage the load or cause operator discomfort. This feature enhances operational safety and prolongs the lifespan of the mast components.



## Smart and reliable strategy for thermal management

The high-capacity trucks utilize three distinct cooling systems to ensure optimal performance and reliability. Specifically, two water cooling systems are employed for the motor and the battery, while an oil cooling system is dedicated to the hydraulics system.

The water cooling systems provide superior cooling performance, preventing the truck from overheating even under the most demanding conditions or in the heat of summer. Water's higher heat transfer capacity compared to air allows it to dissipate heat more efficiently from critical components like the motor and battery. This efficient heat dissipation helps maintain the battery temperature around 30~35 °C , protecting these vital components from overheating and potential damage or failure. Consequently, this enhances the overall reliability and longevity of the high-capacity trucks.

Additionally, water cooling systems typically operate with less noise compared to air cooling systems that rely on high-speed fans. This noise reduction is particularly beneficial in applications where a quieter operation is desirable, such as in urban areas or indoor facilities.

The oil cooling system, on the other hand, is used for the hydraulics system. This system ensures that the hydraulic components remain within optimal temperature ranges, thereby maintaining their efficiency and preventing overheating. By effectively managing the temperature of the hydraulics system, the oil cooling system contributes to the smooth and reliable operation of the truck's hydraulic functions.

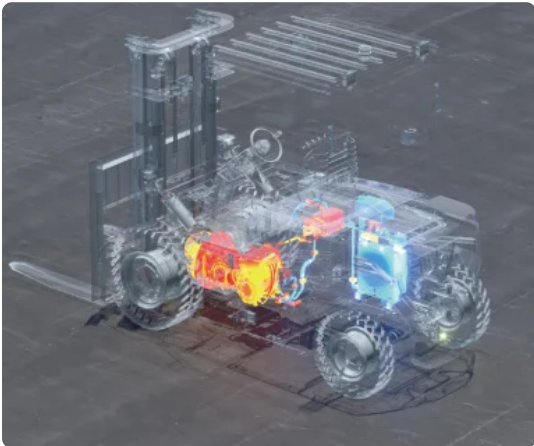

## Low maintenance: Longer battery life span

Operating at a higher voltage allows the battery to be designed with fewer individual cells. With fewer components and a simpler design, the risk of battery failure is lowered.

Thanks to advanced BMS (Battery Management System) which helps to regulate and monitor high-voltage battery, these batteries tend to have a longer life than low-voltage lithium batteries, reducing the need of battery replacement.

The brushless, simple rotor design of PMSM eliminates mechanical wear from brushes and commutators. This durable, low-friction construction requires minimal periodic maintenance, reducing associated labor costs and downtime.

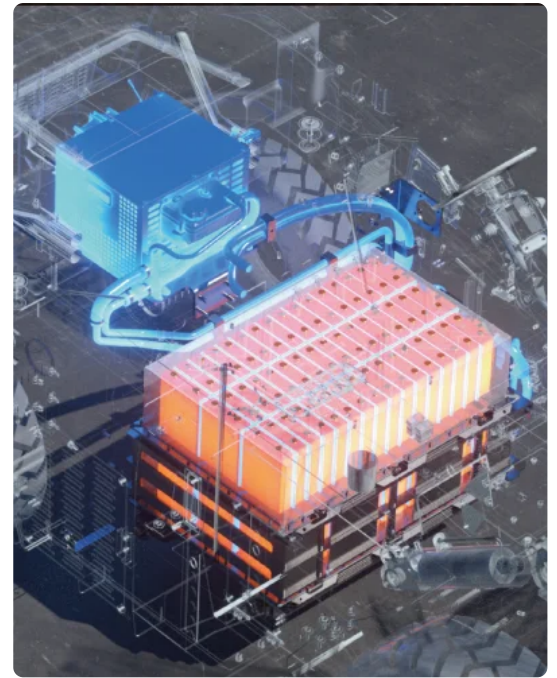

## Sustainability : Zero emissions for cleaner environment

As fully electric trucks powered by lithium-ion batteries, these forklifts produce zero emissions during operation, eliminating exposure to toxic fumes like carbon monoxide and nitrogen oxides. Unlike lead-acid batteries which can leak corrosive acid, lithium-ion batteries do not risk hazardous spills. The high-capacity li-ion trucks contribute to a cleaner and safer indoor working environment without compromising handling capabilities.

## Strong adaptability adaptable to harsh outdoor weather conditions

Experience uninterrupted productivity through rain, puddles, and damp conditions with the overall IPX4 rating. Plus an exceptional IP67 rating for high-voltage components. Engineered to withstand harsh temperature, high-capacity trucks offer an ambient temperature range of -20 °C ~40 °C allowing them to perform no matter climate.

Battery heating when charging comes as a standard function for high capacity models, which is activated when the surrounding temperature is below zero to always offer an optimal temperature range for efficient and safe charging even in cold weather conditions.



The dual front wheels is a standard configuration on several models offering a wider base of support, which greatly improves the forklift's stability. Considering the capacity loads of the high-capacity trucks, the weight of the load is more evenly distributed across a larger surface area. The increased ground contact area provided by the dual wheels enhances traction. This is particularly beneficial in environments where the floor may be slippery or uneven while operating outdoors, ensuring that the forklift can maintain a firm grip and operate safely. This not only helps in maintaining balance but also minimizes the stress on individual tires, extending the lifespan of the tires.

## Great support for clients' investment: After-sales Service

Remote/Online Services:

Telematics technology enables remote monitoring of battery conditions, performance status, and other critical parameters for forklifts. Additionally, production, technical, and after-sales experts are available around the clock to provide prompt and comprehensive solutions for any maintenance issues through virtual support.

Physical Services:

Comprehensive manuals and supporting documents are provided for all forklift models. In case of breakdowns or replacements, spare parts are swiftly delivered to the clients' locations by global subsidiaries or domestic inventory, minimizing operational disruptions caused by equipment downtime.

## VDI Chart

SPECIFICATION	REF	UNIT	VALUE
1.1	Manufacturer		EP

SPECIFICATION		REF	UNIT	VALUE
1.2	Model designation			EFL1203-HV-6
1.3	Drive			Electric
1.4	Operator type			Seated
1.5	Rated capacity	Q	kg	12000
1.6	Load centre distance	c	mm	600
1.8	Load distance, centre of drive axle to fork	x	mm	737
1.9	Wheelbase	y	mm	3000
2.1	Service weight		kg	15500
2.2	Axle loading, laden front/rear		kg	24760/2740
2.3	Axle loading, unladen front/rear		kg	7410/8090
3.1	Tyres			Pneumatic
3.2	Tyre size, front		mm	10.00-20-18PR
3.3	Tyre size, rear		mm	10.00-20-18PR
3.5	Wheels, number front/rear (x=drive wheels)			4x/2
3.6	Tread width, front	b <sub>10</sub>	mm	1748
3.7	Tread width, rear	b <sub>11</sub>	mm	1950
4.1	Tilt of mast/fork carriage forward/backward		°	6/12
4.2	Height, mast lowered	h <sub>1</sub>	mm	3175
4.3	Free lift	h <sub>2</sub>	mm	88
4.4	Lift	h <sub>3</sub>	mm	3000
4.5	Height, mast extended	h <sub>4</sub>	mm	4645
4.7	Height of overhead guard (cabin)		mm	2755
4.8	Seat height relating to SIP/stand height		mm	1700
4.12	Coupling height		mm	490
4.19	Overall length	l <sub>1</sub>	mm	5832
4.20	Length to face of forks	l <sub>2</sub>	mm	4462
4.21	Overall width	b <sub>1</sub> /b <sub>2</sub>	mm	2350
4.22	Fork dimensions	s/e/l	mm	88x175x1370
4.23	Fork carriage ISO 2328, class/type A, B			-
4.24	Fork carriage width		mm	2336
4.31	Ground clearance, laden, below mast		mm	240
4.32	Ground clearance, centre of wheelbase	m <sub>2</sub>	mm	260
4.34.1	Aisle width for pallets 1000×1200 crossways	Ast	mm	6597
4.34.2	Aisle width for pallets 800 × 1200 lengthways	Ast	mm	6597

SPECIFICATION		REF	UNIT	VALUE
4.35	Turning radius	Wa	mm	4290
5.1	Travel speed, laden/unladen		km/h	20/21
5.2	Lift speed, laden/unladen		m/s	0.38/0.44
5.3	Lowering speed, laden/unladen		m/s	0.42/0.4
5.5	Drawbar pull, laden/unladen			/
5.6	Max. drawbar pull, laden/unladen			/
5.8	Max. gradeability, laden/unladen		%	20/25
5.10	Service brake			Hydraulic
5.11	Parking brake			Mechanical
6.1	Drive motor rating S2 60 min		kW	55
6.2	Lift motor rating at S3 15%		kW	2x38
6.4	Battery nominal capacity K5		Ah	304
6.4	Battery voltage		V	309
6.4.1	Battery type			Li-Ion
6.5	Battery weight		kg	860
6.6	Energy consumption according to DIN EN 16796		kWh/h	/ <sup>1)</sup>
6.7	Turnover output according to VDI 2198			/
6.8	Turnover efficiency according to VDI 2198			/
8.1	Type of drive unit			PMSM
10.5	Steering design			Hydraulic
10.7	Sound pressure level at the driver's seat		dB(A)	/
15.1	Charger output current		A	/

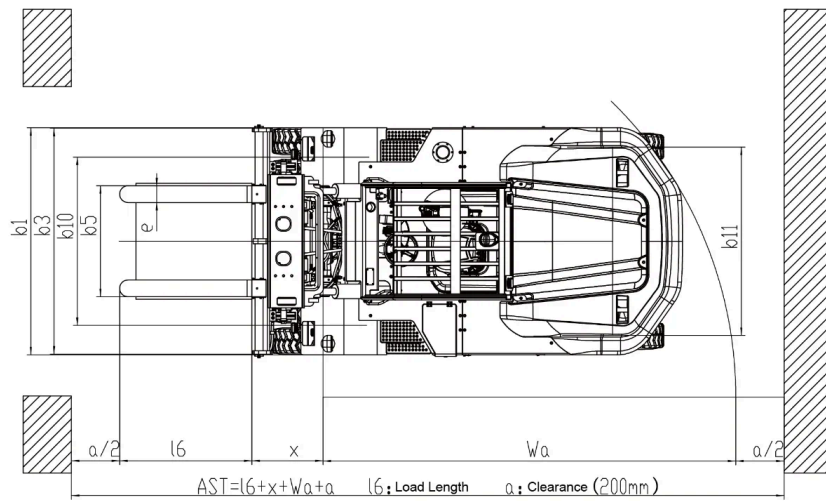
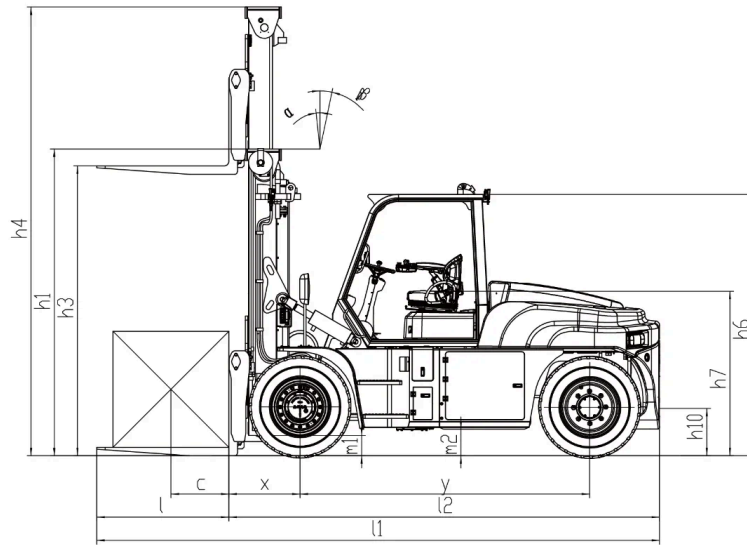

**RATED CAPACITIES AND LOAD CENTERS GRAPH**

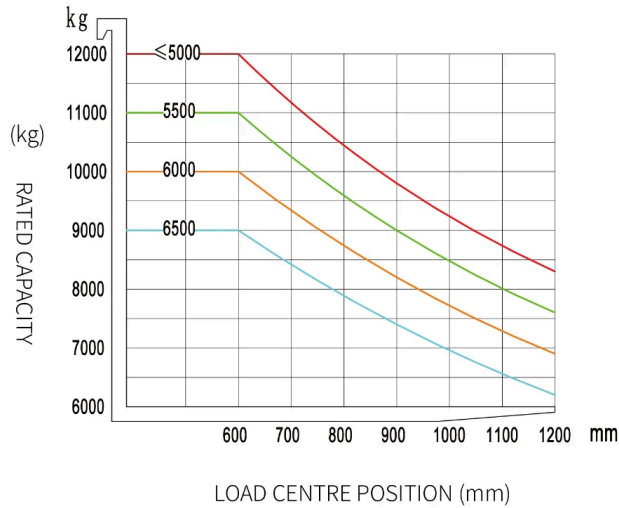

## Mast Options

MAST TYPE	LIFT HEIGHT (H3, MM)	MAST LOWERED HEIGHT (H1, MM)	MAST EXTENDED HEIGHT, NO BACKREST (H4, MM)	MAST EXTENDED HEIGHT, WITH BACKREST (H4, MM)	FREE LIFT HEIGHT, NO BACKREST (H2, MM)	FREE LIFT HEIGHT, WITH BACKREST (H2, MM)
2-Standard Mast	3000	3175	4645	-	88	-
2-Standard Mast	3500	3425	5145	-	88	-
2-Standard Mast	4000	3675	5645	-	88	-
2-Standard Mast	4000	3350	5310	-	200	-
2-Standard Mast	4500	3925	6145	-	88	-
2-Standard Mast	5000	4225	6695	-	88	-
2-Standard Mast	5500	4475	7195	-	88	-
2-Standard Mast	6000	4775	7745	-	88	-
2-Free Mast	3000	3175	4645	-	1500	-
2-Free Mast	3500	3425	5145	-	1750	-
2-Free Mast	4000	3675	5645	-	2000	-
2-Free Mast	4500	3925	6145	-	2250	-
2-Free Mast	5000	4225	6695	-	2500	-

MAST TYPE	LIFT HEIGHT (H3, MM)	MAST LOWERED HEIGHT (H1, MM)	MAST EXTENDED HEIGHT, NO BACKREST (H4, MM)	MAST EXTENDED HEIGHT, WITH BACKREST (H4, MM)	FREE LIFT HEIGHT, NO BACKREST (H2, MM)	FREE LIFT HEIGHT, WITH BACKREST (H2, MM)
2-Free Mast	5500	4475	7195	-	2750	-
2-Free Mast	6000	4775	7745	-	3000	-
2-Free Mast	6500	5025	8245	-	3250	-
2-Free Mast	7000	5325	8795	-	3500	-
3-Free Mast	4500	3225	6215	-	1550	-
3-Free Mast	5000	3392	6715	-	1715	-
3-Free Mast	5500	3608	7265	-	1880	-
3-Free Mast	6000	3775	7765	-	2150	-
3-Free Mast	6500	3992	8315	-	2215	-
3-Free Mast	7000	4208	8865	-	2380	-

## Options

ITEM	OPTIONS (optional items marked in yellow)
Fork dimension	Fork positioner with pin type forks   Customized fork length/non-standard accessories   1370mm forks
Fork carriage width option	Customized fork carriage width   2336 fork carriage
Backrest height	Customized fork backrest
Battery capacity	309V304Ah LFP battery   309V228Ah LFP battery
Charger	20kw (3 phase AC 370V-460V, 50-60HZ, 32A plug)   40kw (3 phase AC 370V-460V, 50-60HZ, 63A plug)
Seat type	Upgraded suspension seat with armrest + headrest + safety seat-belt switch   Grammer MSG65-531 (suspension seat with armrest + safety belt switch)
Attachments	Fork positioner with sideshift: Forks with terminal west   Fork positioner with sideshift: Roller-guided forks
Buzzer	Yes
Camera	Reversing radar/reversing camera/reversing radar and camera
OPS system	Yes
USB interface	USB interface 24V
Telematics	Yes

ITEM	OPTIONS (optional items marked in yellow)
Cabin	Basic half-cabin: front windshield, front wiper (including sprinkler), roof   Upgrade half-cabin: basic half-cabin, rear windshield, rear wiper   Basic full cabin: upgrade half-cabin, left and right doors, defogging function   Upgrade full cabin: basic full cabin, air conditioner
Overhead guard	Standard overhead guard
Turn speed control	Yes
Heating system during lithium battery charging	Yes
Options	Fingertips   Cigarette lighter socket 12V5A
Tyres type	Pneumatic   Solid tyres / non-marking tyres
Mast lifting and lowering buffer	Yes
Mechanical lever	Yes
Rear grab handle with horn	Yes
Lighting package	LED front working light, turn signal light, market light, LED rear working light, strobe warning light   LED working lights on mast   Rotating warning light / rotating buzzer warning light   Rear/rear and front blue lamp   Front fog light   Customized area warning lamp
Adjustable overspeed alarm	Yes