



EFL603-HV-6

HIGH CAPACITY ELECTRIC COUNTERBALANCED FORKLIFT 6.0T

 6000 kg  7000 mm  309 V Li-Ion



The EFL503–703HV Series is purpose-built for industries that demand strength, reliability, and safety in extreme working conditions — such as steel production, construction materials, ports, and heavy logistics. Its dual-wheel front axle enhances traction and balance when transporting bulky materials on uneven or slippery ground. With its fast 1C charging capability and long battery life (up to 4000 cycles), it is the ideal solution for multi-shift operations that require continuous power and minimal downtime.

SPECIFICATION	REF	UNIT	VALUE
Battery type			Li-Ion
Battery nominal capacity K5		Ah	228
Battery voltage		V	309
Rated capacity	Q	kg	6000
Load centre distance	c	mm	600
Service weight		kg	9250
Height, mast lowered	h_1	mm	2480
Lift	h_3	mm	3000
Height, mast extended	h_4	mm	4470/3965
Overall length	l_1	mm	4720
Overall width	b_1/b_2	mm	2028
Length to face of forks	l_2	mm	3500
Fork dimensions	s/e/l	mm	60×150×1220
Turning radius	wa	mm	3235
Manufacturer			EP
Model designation			EFL603-HV-6

Features

High Performance: High speed and high gradeability

High-voltage Li-ion batteries enable more power delivery to motors, improving acceleration and travel speeds for high-capacity trucks. PMSMs complement this with rapid response times, swiftly reaching required speeds and torques. This combination of PMSM and high voltage can provide stable and strong power output, which further gives high-capacity trucks excellent climbing capabilities ensuring that the forklift can cope with various applications with ease.

The high-voltage model offers a 1.5-2 times performance improvement over the low-voltage model. Taking the 10-ton model as an example:

100% improvement in travel speed for high voltage models in laden and unladen conditions.

The high-voltage model demonstrates a 45% faster lifting speed.

100% improvement in gradeability when unladen, 45% improvement when laden for high voltage models.

Energy Efficiency: extended runtime and fast charging

High-voltage Li-ion batteries have high energy density and can store more electrical energy within a compact volume. High-voltage systems consume less energy and provide longer battery running time comparing low-voltage systems. Notably, these high-voltage Li-ion batteries boast an impressive cycle life of up to 4000 cycles, ensuring long-term durability and minimizing the need for battery replacements.

The PMSMs incorporate advanced control technology to optimize motor efficiency. Unlike traditional AC motors, PMSMs have higher energy conversion efficiency and reduce energy waste. This means that high-capacity trucks can work continuously for prolonged hours at lower costs.

Equipped with fast charging capabilities, high-capacity trucks offer a remarkable charging experience. The high-voltage models are compatible with vehicle-grade charging stations and support 1C charging rating, allowing them to be fully charged in as fast as 1-1.2 hours. This minimizes downtime and maximizes productivity, making it ideal for multi-shift operations

Lithium batteries present considerably lower charging costs than fuel expenses. The integration of high-voltage and PMSM technology achieves up to 15% greater electricity savings versus traditional lithium and AC technology configurations. This significantly reduces long-term energy consumption costs.



Safety Assured: Battery, motor protection, monitoring and mast buffering

Both high-voltage lithium batteries and PMSM employ multiple protective measures to ensure safe operations including overcharge protection, over-temperature monitoring, short-circuit protection, etc. minimizing the risk of potential hazards and maximizing operational safety.

The central controlling module- VCU (Vehicle Control Unit) extends the safety of the high-voltage forklifts. VCU provides precise control and real-time monitoring of critical parameters to ensure the truck operates within safe limits.

It also features turn speed control, which adjusts the forklift's speed based on the turning angle, ensuring stability during turns. An over-speed alarm alerts the operator if the forklift exceeds the safe speed limit.*

The high-capacity forklift mast is equipped with a hydraulic buffering system that ensures smooth lifting and lowering of loads. With controlled deceleration, the fork movement is smooth with no abrupt stops that could damage the load or cause operator discomfort. This feature enhances operational safety and prolongs the lifespan of the mast components.



Low maintenance: Longer battery life span

Operating at a higher voltage allows the battery to be designed with fewer individual cells. With fewer components and a simpler design, the risk of battery failure is lowered.

Thanks to advanced BMS (Battery Management System) which helps to regulate and monitor high-voltage battery, these batteries tend to have a longer life than low-voltage lithium batteries, reducing the need of battery replacement.

The brushless, simple rotor design of PMSM eliminates mechanical wear from brushes and commutators. This durable, low-friction construction requires minimal periodic maintenance, reducing associated labor costs and downtime.

Strong adaptability adaptable to harsh outdoor weather conditions

Experience uninterrupted productivity through rain, puddles, and damp conditions with the overall IPX4 rating. Plus an exceptional IP67 rating for high-voltage components. Engineered to withstand harsh temperature, high-capacity trucks offer an ambient temperature range of -20 °C ~40 °C allowing them to perform no matter climate.

Battery heating when charging comes as a standard function for high capacity models, which is activated when the surrounding temperature is below zero to always offer an optimal temperature range for efficient and safe charging even in cold weather conditions.

The dual front wheels is a standard configuration on several models offering a wider base of support, which greatly improves the forklift's stability. Considering the capacity loads of the high-capacity trucks, the weight of the load is more evenly distributed across a larger surface area. The increased ground contact area provided by the dual wheels enhances traction. This is particularly beneficial in environments where the floor may be slippery or uneven while operating outdoors, ensuring that the forklift can maintain a firm grip and operate safely. This not only helps in maintaining balance but also minimizes the stress on individual tires, extending the lifespan of the tires.



VDI Chart

	SPECIFICATION	REF	UNIT	VALUE
1.1	Manufacturer			EP
1.2	Model designation			EFL603-HV-6
1.3	Drive			Electric
1.4	Operator type			Seated
1.5	Rated capacity	Q	kg	6000
1.6	Load centre distance	c	mm	600
1.8	Load distance, centre of drive axle to fork	x	mm	603.5
1.9	Wheelbase	y	mm	2300
2.1	Service weight		kg	9250
2.2	Axle loading, laden front/rear		kg	13755/1495
2.3	Axle loading, unladen front/rear		kg	4610/4640

SPECIFICATION		REF	UNIT	VALUE
3.1	Tyres			Pneumatic
3.2	Tyre size, front		mm	8.25-15-14PR
3.3	Tyre size, rear		mm	8.25-15-14PR
3.5	Wheels, number front/rear (x=drive wheels)			4x/2
3.6	Tread width, front	b_{10}	mm	1498
3.7	Tread width, rear	b_{11}	mm	1718
4.1	Tilt of mast/fork carriage forward/backward		°	6/12
4.2	Height, mast lowered	h_1	mm	2480
4.2.1	Overall height		mm	4470
4.3	Free lift	h_2	mm	160
4.4	Lift	h_3	mm	3000
4.5	Height, mast extended	h_4	mm	4470/3965
4.6	Initial lift		mm	160
4.7	Height of overhead guard (cabin)		mm	2590
4.8	Seat height relating to SIP/stand height		mm	1490
4.12	Coupling height		mm	600
4.15	Height, lowered	h_{13}	mm	2480
4.16	Length of loading surface			3500
4.19	Overall length	l_1	mm	4720
4.20	Length to face of forks	l_2	mm	3500
4.21	Overall width	b_1/b_2	mm	2028
4.22	Fork dimensions	s/e/l	mm	60×150×1220
4.23	Fork carriage ISO 2328, class/type A, B			4A
4.24	Fork carriage width		mm	1845 (1995)
4.26	Distance between wheel arms/loading surfaces			600
4.31	Ground clearance, laden, below mast		mm	160
4.32	Ground clearance, centre of wheelbase	m_2	mm	265
4.34.1	Aisle width for pallets 1000×1200 crossways	A_{st}	mm	5260
4.34.2	Aisle width for pallets 800 × 1200 lengthways	A_{st}	mm	5260
4.35	Turning radius	W_a	mm	3235
4.36	Internal turning radius			3235
5.1	Travel speed, laden/unladen		km/h	25/26
5.2	Lift speed, laden/unladen		m/s	0.51/0.53
5.3	Lowering speed, laden/unladen		m/s	0.48/0.42

	SPECIFICATION	REF	UNIT	VALUE
5.8	Max. gradeability, laden/unladen		%	30/34
5.10	Service brake			Hydraulic
5.11	Parking brake			Mechanical
6.1	Drive motor rating S2 60 min		kW	60
6.2	Lift motor rating at S3 15%		kW	2x27.8
6.4	Battery nominal capacity K5		Ah	228
6.4	Battery voltage		V	309
6.4.1	Battery type			Li-Ion
6.5	Battery weight		kg	693
8.1	Type of drive unit			PMSM
10.5	Steering design			Hydraulic
10.7	Sound pressure level at the driver's seat		dB(A)	/

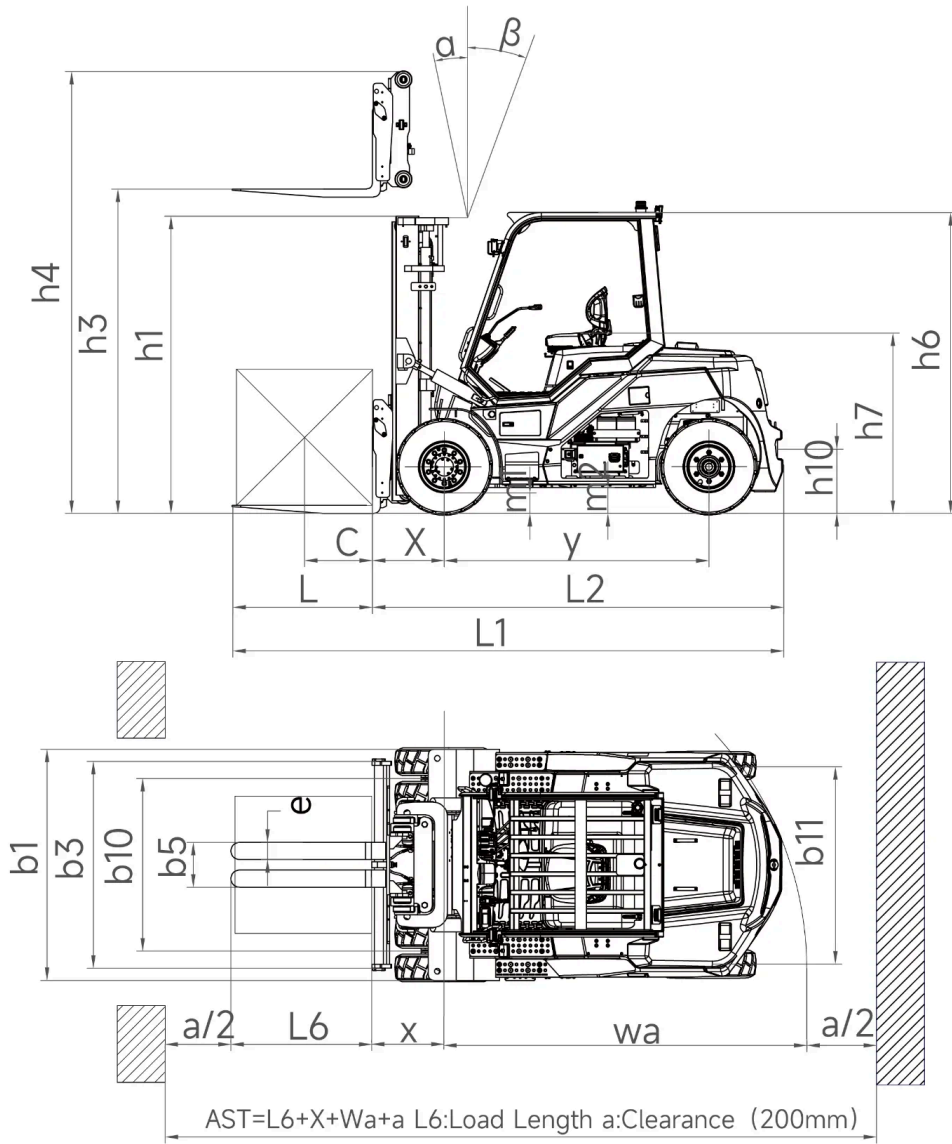

EFL603-HV-6 RATED CAPACITIES AND LOAD CENTERES GRAPH



Mast Options

MAST TYPE	LIFT HEIGHT (H3, MM)	MAST LOWERED HEIGHT (H1, MM)	MAST EXTENDED HEIGHT, NO BACKREST (H4, MM)	MAST EXTENDED HEIGHT, WITH BACKREST (H4, MM)	FREE LIFT HEIGHT, NO BACKREST (H2, MM)	FREE LIFT HEIGHT, WITH BACKREST (H2, MM)
2-Standard Mast	3000	2480	3960	4470	160	160
2-Standard Mast	3500	2730	4460	4970	160	160
2-Standard Mast	4000	2980	4960	5470	160	160
2-Standard Mast	4500	3280	5460	5970	160	160
2-Standard Mast	5000	3530	5960	6470	160	160
2-Standard Mast	5500	3830	6460	6970	160	160
2-Standard Mast	6000	4080	6960	7470	160	160

MAST TYPE	LIFT HEIGHT (H3, MM)	MAST LOWERED HEIGHT (H1, MM)	MAST EXTENDED HEIGHT, NO BACKREST (H4, MM)	MAST EXTENDED HEIGHT, WITH BACKREST (H4, MM)	FREE LIFT HEIGHT, NO BACKREST (H2, MM)	FREE LIFT HEIGHT, WITH BACKREST (H2, MM)
2-Standard Mast	6500	4380	7460	7970	160	160
2-Free Mast	3000	2480	4310	4470	1495	1313
2-Free Mast	3500	2730	4810	4970	1700	1580
2-Free Mast	4000	2980	5310	5470	1995	1813
3-Free Mast	4500	2660	5636	5976	1560	1220
3-Free Mast	4800	2760	5936	6276	1660	1320
3-Free Mast	5000	2810	6086	6476	1760	1370
3-Free Mast	5500	3010	6686	6976	1860	1570
3-Free Mast	6000	3160	7136	7476	2060	1720
3-Free Mast	6500	3310	7586	7976	2260	1870
3-Free Mast	7000	3610	8286	8476	2360	2170

Options

ITEM	OPTIONS (optional items marked in yellow)
Fork dimension	1220mm Hook-on forks Customized fork length/non-standard accessories
Fork carriage width option	Customized fork carriage width
Backrest height	1995mm load backrest
Battery capacity	309V228Ah LFP battery 309V304Ah LFP battery
Charger	20kw (AC 370V-460V, 50-60HZ, 32A plug) 40kw (AC 370V-460V, 50-60HZ, 63A plug)
Seat type	Upgraded suspension seat with armrest + headrest + safety seat-belt switch Grammer MSG65-531 (suspension seat with armrest + safety belt switch)
Attachments	Hook on type sideshift Hook on type fork positioner with sideshift Fork positioner with pin type forks
Buzzer	Yes
Camera	Reversing radar/reversing camera/reversing radar and camera
OPS system	Yes
USB interface	USB interface 24V
Overhead guard	Standard overhead guard

ITEM	OPTIONS (optional items marked in yellow)
Turn speed control	Yes
Heating system during lithium battery charging	Yes
Mast lifting and lowering buffer	Yes
Mechanical lever	Yes
Rear grab handle with horn	Yes
Lighting package	LED front working light, turn signal light, market light, LED rear working light, strobe warning light LED working lights on mast Rotating warning light / rotating buzzer warning light Rear/rear and front blue lamp Front fog light Customized area warning lamp
Options	Fingertips Cigarette lighter socket 12V5A
Tyres type	Pneumatic Solid tyres / non-marking tyres