



# CQD15SS

## Electric Standing Reach Truck 1.5t

Best choice for narrow aisle and high shelf stacking condition;  
Standing operation get wide vision, convenient entry and get off;  
EPS control makes steering operation more efficient and comfortable.

EP EQUIPMENT CO.,LTD  
[www.ep-ep.com](http://www.ep-ep.com)

# Electric Standing Reach Truck 1.5t CQD15SS

Distinguishing mark				
1.1	Manufacturer			EP
1.2	Model designation			CQD15SS
1.3	Drive unit			Battery
1.4	Operator type			standing
1.5	rated capacity	Q	t	1.5
1.6	Load center distance	c	mm	600
1.9	Wheelbase	y	mm	1513
Weight				
2.1	Service weight (include battery)		kg	①2285
2.2	Axle loading, fork advanced, unladen driving side/loading side		kg	1437/880
2.3	Axle loading, fork retracted, unladen driving side/loading side		kg	1517/800
2.4	Axle loading, fork advanced, laden driving side/loading side		kg	780/3100
2.5	Axle loading, fork retracted, laden driving side/loading side		kg	1435/2415
Types,Chassis				
3.1	Tyre type driving wheels/loading wheels			polyurethane/polyurethane
3.2	Tyre size, driving wheels (diameter×width)		mm	Φ260× 105
3.3	Tyre size, loading wheels (diameter×width)		mm	Φ102× 73
3.4	Tyre size, caster wheels (diameter×width)		mm	Φ178×73
3.5	Wheels, number driving, caster/loading (x=drive wheels)		mm	1×, 2/4
3.6	Track width, front,driving side	b10	mm	520
3.7	Track width,rear,loading side	b11	mm	978
Dimensions				
4.1	Tilt of mast/fork carriage forward/backward	α/ β	°	2/4
4.2	Height, mast lowered	h1	mm	2245②
4.3	Free lift (load backrest)	h2	mm	0②
4.4	Lift height	h3	mm	3000②
4.5	Height, mast extended	h4	mm	3960②
4.7	Height of overhead guard (cabin)	h6	mm	2245
4.8	Seat height/standing height	h7	mm	340
4.10	Height of wheel arms	h8(mm)	mm	135
4.19	Overall length (minimum)	l1	mm	2415③
4.20	Length to face of forks	l2	mm	1345
4.21	Overall width	b1/ b2	mm	1078
4.22	Fork dimensions	s/ e/ l	mm	40/100/1070
4.23	Fork carriage class/type A, B		mm	A
4.24	Fork carriage width	b3	mm	800
4.25	Outside width of the forks	b5	mm	200-780
4.26	Distance between wheel arms/loading surfaces	b4	mm	878
4.28	Reach distance	l4	mm	590
4.31	Ground clearance, laden, below mast	m1	mm	70
4.32	The minimum ground clearance of frame	m2	mm	70
4.34.1	Aisle width for pallets 1000 × 1200 crossways	Ast	mm	③2805
4.34.2	Aisle width for pallets 800 × 1200 lengthways	Ast	mm	③2845
4.35	turning radius	Wa	mm	1785
4.37	Length across wheel arms (exclusive fork)	l7	mm	1920
Performance data				
5.1	Travel speed, laden/ unladen		km/ h	8.5/9
5.2	Lifting speed, laden/ unladen		m/ s	0.26/0.39
5.3	Lowering speed, laden/ unladen		m/ s	0.47/0.47
5.4	Reaching speed, laden / unladen		m/ s	0.18/0.18
5.8	Max. gradeability, laden/unladen		%	8/10
5.10	Service brake type			Electromagnetic
	Park brake type			Electromagnetic
Electric-engine				
6.1	Drive motor rating S2 60 min		kW	4
6.2	Lift motor rating at S3 15%		kW	8.2
6.3	The maximum allowed size battery		mm	1030×353×784
6.4	Battery voltage/nominal capacity K5		V/ Ah	48V/420Ah④
6.5	Battery weight		kg	739④
Addition data				
8.1	Park brake type			AC
10.5	Steering type			Electronic
10.7	Sound pressure level at the driver's ear		dB (A)	75

1.The parameters in the table are of the standard model. For more information, please contact us.

2.The parameters are subject to change without notice.

①Service weight (include battery)

Mast height (mm)	Service weight (kg)
2-stage mast	
2700	2275
3000	2285
3300	2295
3600	2305
4000	2315
4300	2325

3-stage mast	
4000	2515
4500	2530
4800	2540
5000	2545
5500	2560

②Mast

2-stage mast			
Lift height	Lowered mast height	Free lift	Extended mast height
h3	h1	h2	h4
2700	1940	0	3660
3000	2090	0	3960
3300	2240	0	4260
3600	2390	0	4560
4000	2590	0	4960
4300	2740	0	5260

3-stage mast			
Lift height	Lowered mast height	Free lift	Extended mast height
h3	h1	h2	h4
4000	1960	1000	4955
4500	2130	1170	5455
4800	2230	1270	5760
5000	2295	1335	5960
5500	2460	1500	6460

③Dimensions(mm)

		2-stage mast	3-stage mast
Overall length (minimum)	l1	2415	2430
Aisle width for pallets 1000×1200 crossways	Ast	2805	2820
Aisle width for pallets 800×1200 lenthways	Ast	2845	2860
Aisle width for pallets 1000×1200 lenthways	Ast	2895	2910
Aisle width for pallets 800×1200 crossways	Ast	2685	2695

④Battery

	Capacity(Ah)	Battery weight (kg)
1	345	560
2	360	620
3	420	739
4	450	739
5	465	739

**RATED CAPACITIES GRAPH**

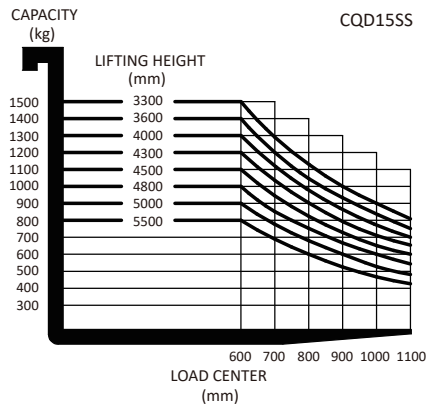

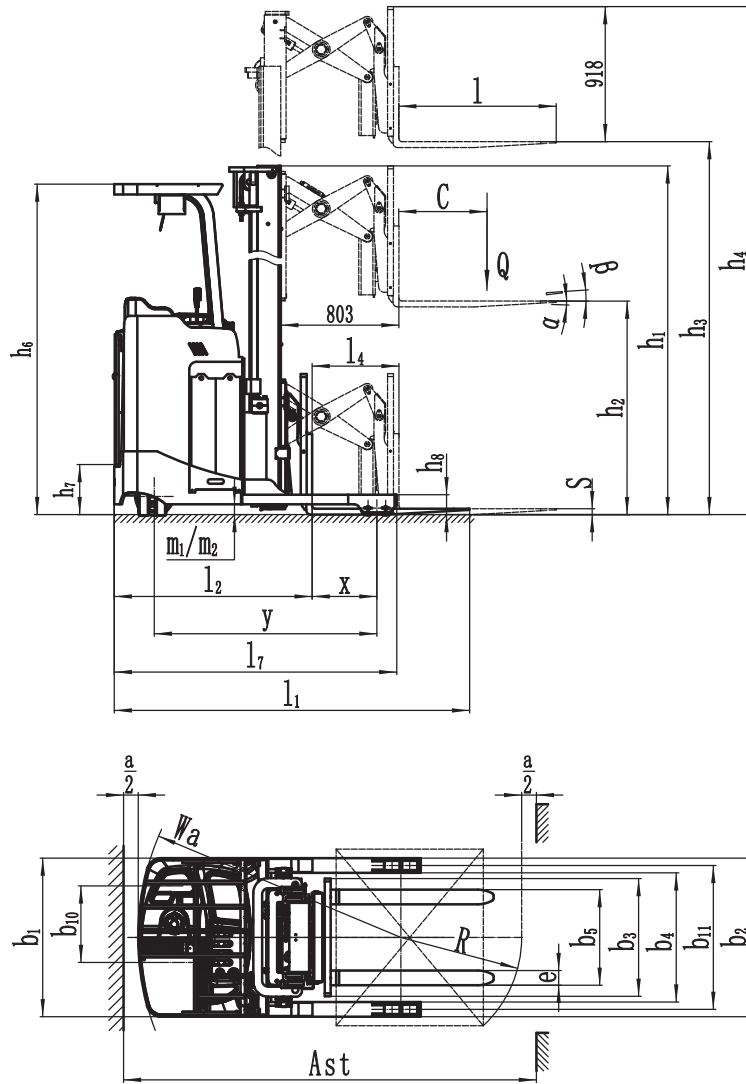

## Option

Options	CQD15SS
Driving pedal	—
Electronic Power steering	•
Battery capacity	•420Ah ○300/345/360/465Ah
Lateral change battery	•
Cold storage	○
Side shift	○
Front light and warning light	•
Rearview mirror	•
Hummer	○
Height display	—
Camera	○
Fire extinguisher	○
The front wheel side guard	—
Drive-in Rack	○
Seat switch	—
Water auto-fillingsystem	○

Note: • standard ○ option — NA