



EFL35 PRO

4-WHEEL LI-ION COUNTERBALANCE FORKLIFT 3.5T

 3500 kg  6000 mm  80 V Li-Ion



Built to perform across diverse environments, the EFL Pro Series excels in warehouses, factories, logistics centers, ports, and construction yards. Its high ground clearance, large tires and IPX4 water resistance enable operation on uneven outdoor terrain, while its compact turning radius and quiet, emission-free power make it ideal for indoor use as well. Designed to replace traditional diesel forklifts, the EFL Pro provides high performance with reduced operating costs

SPECIFICATION	REF	UNIT	VALUE
Battery type			Li-Ion
Battery nominal capacity K5		Ah	280
Battery voltage		V	80
Rated capacity	Q	kg	3500
Load centre distance	c	mm	500
Service weight		kg	5250
Height, mast lowered	h_1	mm	2065
Lift	h_3	mm	3000
Height, mast extended	h_4	mm	4130
Overall length	l_1	mm	3682
Overall width	b_1/b_2	mm	1210
Length to face of forks	l_2	mm	2612
Fork dimensions	s/e/l	mm	50×122×1070
Turning radius	Wa	mm	2395
Manufacturer			EP
Model designation			EFL 35 PRO

Features

Unmatched Performance and experience

Powered by a 17kW AC driving motor and 30kW PMS pump motor system, the EFL PRO achieves performance, gradeability and residual capacity in line with the best electric forklift with the advantage of the high ground clearance, the big size tires and robust chassis.

EFL PRO hydraulic system feature:

- Full-proportion solenoid valve for a more accurate micro-control
- PMS pump motor and screw type pump for precise and silent hydraulic operation
- Big diameter hydraulic tubing for high oil flow also on the attachments

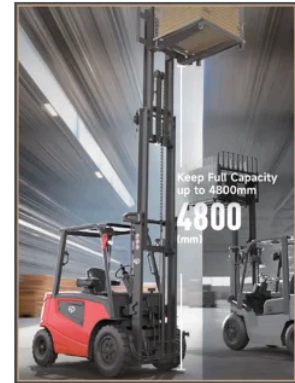

Sleek Appearance with Enhanced Versatility

The EFL PRO Series combines a sleek, fully-molded design with outstanding stability, thanks to its extended 1753 mm wheelbase. Despite its robust stance, key dimensions—such as width and turning radius—remain comparable to standard electric forklifts, ensuring versatility in any application. Modern LED lighting enhances visibility and reinforces its contemporary look, while the electric parking brake and automatic stop on ramp further elevate safety and control

State of the art controls on the armrest

Multiple functions are integrated at the palm-size end with fingertip or joystick and includes:

forward/reverse direction switch, lifting/lowering, tilting, sideshift and 4th way, horn, turning light switch, Storage box and USB port, emergency switch

Optional: fork leveling button, clamp interlock button, 5th way button switch can complete the operator controls





Multi-functional Full-touch Display

The new OLED touchscreen display provides real-time monitoring of all key forklift operating parameters, including battery state of charge, driving speed, travel direction, wheel angle, operating hours, date and time. Optional functions such as mast tilt angle, lift height and load weight indicators can also be integrated. Thanks to its touch interface, the operator can easily control all auxiliary systems, including the lighting system, wipers, and cabin heater.

Ergonomic Cabin for Fatigue-free Operation

The EFL PRO's ergonomic design begins the moment the operator steps aboard, thanks to the largest access step in its class. Once inside, the EFL PRO features a offering a spacious driving area with a standard suspended seat with armrest. A reduced-size steering wheel, a tempered glass roof for enhanced visibility, and practical storage compartments further elevate the operator experience. For ease of service, power and auxiliary controllers are housed in a protected area accessible through removable panels.



Revolutionary Li-ion Battery and Charging System

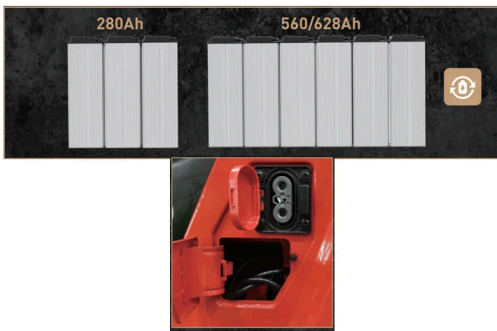

At the core of the EFL PRO Series is EP's breakthrough Li-ion technology — a new Li-ion battery system composed of three independent battery modules operating in series to achieve 80V. Each module functions autonomously, ensuring consistent performance and enhanced reliability. This battery architecture enables power from 280Ah to 560Ah or 628Ah, allowing the EFL PRO to adapt its endurance to a wide range of applications. Furthermore, through a dedicated upgrade kit, the dealer is able to adjust such battery power capacity to meet evolving customer requirements.

Additionally, each battery module can be repaired or replaced individually, eliminating the costly full-pack replacements typically required when single cells fail. For further charging convenience, both integrated charging and external charging port are available on one truck making EFL PRO flexible for all kinds of applications needs.

Telematic and innovative options

EFL PRO comes standard with ergonomic armrest equipped with fingertip or joystick hydraulic controls, automatic speed reduction on turns and with telematic system that allows to manage the fleet and the rental activities in an effective and efficient manner. The system tracks data for truck and battery usage, like uptime, battery status and real-time location. It allows dealers to monitor and analyze assets conditions, providing remote diagnostics and improving the efficiency of fleet management.

The following items are available as optional equipment:

Full cabin with integrated heater on the dashboard and operator feet; Load-leveling function activated at the press of a single button; Load height indicator; Load weight indicator; Panoramic OHG with glass roof; 360°Panorama System with human recognition and collision warning (no CE); Ambient-noise Adaptive Buzzer(no CE)



VDI Chart

	SPECIFICATION	REF	UNIT	VALUE
1.1	Manufacturer			EP
1.2	Model designation			EFL 35 PRO
1.3	Drive			Electric
1.4	Operator type			Seated

	SPECIFICATION	REF	UNIT	VALUE
1.5	Rated capacity	Q	kg	3500
1.6	Load centre distance	c	mm	500
1.8	Load distance, centre of drive axle to fork	x	mm	486
1.9	Wheelbase	y	mm	1753
2.1	Service weight		kg	5250
2.2	Axle loading, laden front/rear		kg	7748/1002
2.3	Axle loading, unladen front/rear		kg	2267/2983
3.1	Tyres			Pneumatic
3.2	Tyre size, front		mm	28X9-15-14PR
3.3	Tyre size, rear		mm	6.50-10-10PR
3.5	Wheels, number front/rear (x=drive wheels)			2x/ 2
3.6	Tread width, front	b ₁₀	mm	1010
3.7	Tread width, rear	b ₁₁	mm	980
4.1	Tilt of mast/fork carriage forward/backward		°	6/ 6
4.2	Height, mast lowered	h ₁	mm	2065
4.3	Free lift	h ₂	mm	135
4.4	Lift	h ₃	mm	3000
4.5	Height, mast extended	h ₄	mm	4130
4.7	Height of overhead guard (cabin)	h ₆	mm	2170
4.8	Seat height relating to SIP/stand height	h ₇	mm	1138
4.12	Coupling height	h ₁₀	mm	510
4.19	Overall length	l ₁	mm	3682
4.20	Length to face of forks	l ₂	mm	2612
4.21	Overall width	b ₁ /b ₂	mm	1210
4.22	Fork dimensions	s/e/l	mm	50×122×1070
4.23	Fork carriage ISO 2328, class/type A, B			3A
4.24	Fork carriage width		mm	1100
4.31	Ground clearance, laden, below mast		mm	130
4.32	Ground clearance, centre of wheelbase	m ₂	mm	165
4.34.1	Aisle width for pallets 1000×1200 crossways	Ast	mm	4081
4.34.2	Aisle width for pallets 800 × 1200 lengthways	Ast	mm	4281
4.35	Turning radius	Wa	mm	2395
5.1	Travel speed, laden/unladen		km/h	19/20
5.2	Lift speed, laden/unladen		m/s	0.49/0.52

	SPECIFICATION	REF	UNIT	VALUE
5.3	Lowering speed, laden/unladen		m/s	0.43/0.44
5.5	Drawbar pull, laden/unladen			5924
5.6	Max. drawbar pull, laden/unladen			22350
5.8	Max. gradeability, laden/unladen		%	20/28
5.10	Service brake			Mechanical/Hydraulic
5.11	Parking brake			Electromagnetic
6.1	Drive motor rating S2 60 min		kW	17
6.2	Lift motor rating at S3 15%		kW	30
6.4	Battery nominal capacity K5		Ah	280
6.4	Battery voltage		V	80
6.4.1	Battery type			Li-Ion
6.5	Battery weight		kg	184
6.6	Energy consumption according to DIN EN 16796		kWh/h	9.34
6.7	Turnover output according to VDI 2198			217
6.8	Turnover efficiency according to VDI 2198			22.96
8.1	Type of drive unit			AC
10.1	Operating pressure for attachments		bar	180
10.2	Oil volume for attachments		ℓ/min	35
10.5	Steering design			Hydraulic
10.7	Sound pressure level at the driver's seat		dB(A)	70

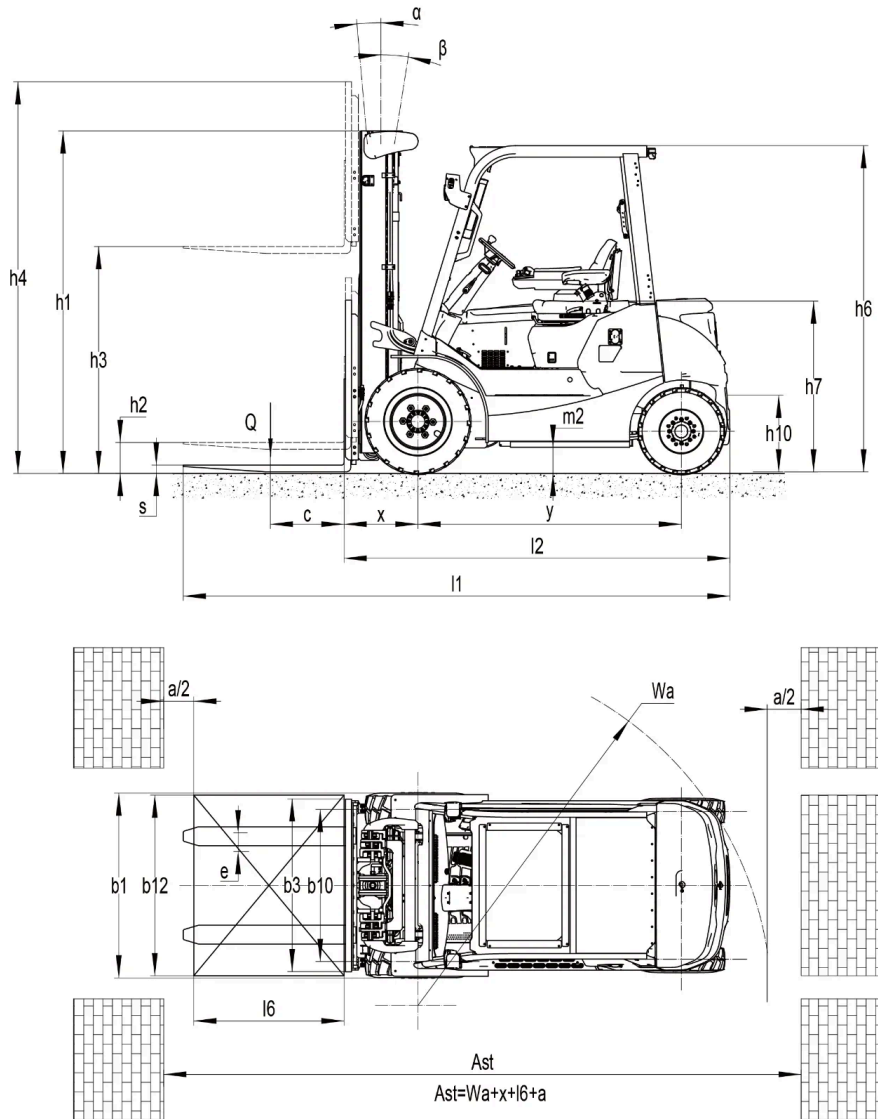

EFL 35 PRO

RATED CAPACITIES GRAPH

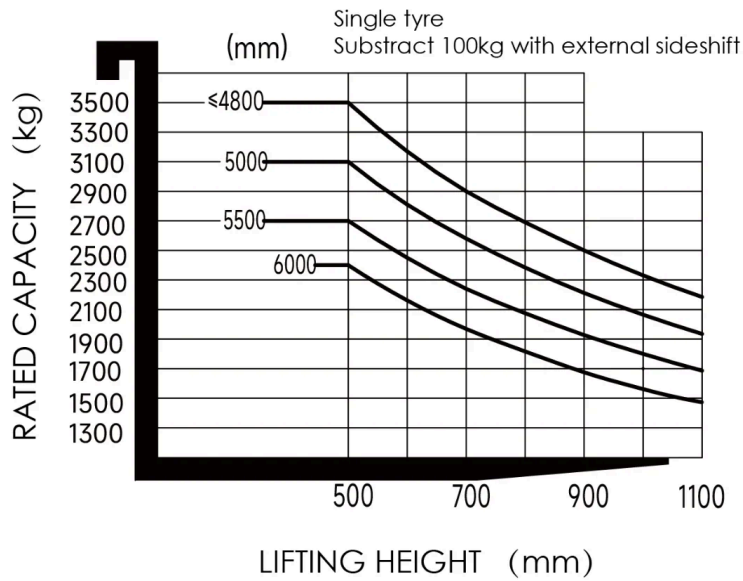

Mast Options

MAST TYPE	LIFT HEIGHT (H3, MM)	MAST LOWERED HEIGHT (H1, MM)	MAST EXTENDED HEIGHT, NO BACKREST (H4, MM)	MAST EXTENDED HEIGHT, WITH BACKREST (H4, MM)	FREE LIFT HEIGHT, NO BACKREST (H2, MM)	FREE LIFT HEIGHT, WITH BACKREST (H2, MM)
2-Standard Mast	2700	1915	3365	3830	135	135
2-Standard Mast	3000	2065	3665	4130	135	135
2-Standard Mast	3300	2215	3965	4430	135	135
2-Standard Mast	3500	2315	4165	4630	135	135
2-Standard Mast	3600	2365	4265	4730	135	135
2-Standard Mast	4000	2615	4665	5130	135	135
2-Standard Mast	4500	2865	5165	5630	135	135
2-Free Mast	3000	2045	3715	4175	1410	950
2-Free Mast	3300	2195	4015	4475	1560	1100
2-Free Mast	3600	2345	4315	4775	1710	1250
3-Free Mast	4300	2080	5030	5435	1390	985
3-Free Mast	4500	2160	5270	5675	1470	1065

MAST TYPE	LIFT HEIGHT (H3, MM)	MAST LOWERED HEIGHT (H1, MM)	MAST EXTENDED HEIGHT, NO BACKREST (H4, MM)	MAST EXTENDED HEIGHT, WITH BACKREST (H4, MM)	FREE LIFT HEIGHT, NO BACKREST (H2, MM)	FREE LIFT HEIGHT, WITH BACKREST (H2, MM)
3-Free Mast	4800	2265	5570	5975	1575	1170
3-Free Mast	5000	2350	5720	6125	1660	1255
3-Free Mast	5500	2600	6220	6625	1910	1505
3-Free Mast	6000	2850	6720	7125	2160	1755

Options

ITEM	OPTIONS (optional items marked in yellow)
Fork dimension	122*50*1070 122*50*1150 122*50*1220 122*50*1370 122*50*1520
Front wheel material	Pneumatic Normal solid Traceless solid
Rear wheel material	Pneumatic Normal solid Traceless solid
Battery capacity	80V280AH 80V560AH 80V628AH (NON-CE)
Charger	80V65A (NON-CE) 80V60A (CE) 80V35A integrated 80V60A integrated 80V130A 80V150A 80V200A (560/628AH)
Battery display indicator (BDI)	With time (Bluetooth)
Seat type	Comfortable + safety belt switch (41) Suspension seat with armrest and safety belt swich GRAMMER-MSG65
Attachments	Built-in sideshifter External shifter Fork positionr with sideshift External shifter with adjustable forks Clamp
Traction pin	Yes and not customized
Anti-static chain	Yes and not customized
Front lamp	LED
Rear lamp	No LED
Warning lamp	Yes and not customized
Steering lamp	LED
Blue lamp	No Rear Front and rear
Area warning lamp	No Both sides Both sides and rear
Rearview mirror	One in front Two on sides and one in front
Buzzer	Regular buzzer Ambient-noise adaptive buzzer (NON-CE)
OPS system	Yes and not customized

ITEM	OPTIONS (optional items marked in yellow)
USB interface	Cigarette lighter+USB with A and C type
Telematics	Yes and not customized No
Cabin	No Basic semi-cabin Upgraded semi-cabin Full cabin
Overhead guard	Strip glass with anti-explosion film Panoramic glass roof (NON-CE)
Clamp interlock	No Yes and not customized
Special AUS/NZ options	No Yes and not customized
Turn speed control	Yes and not customized No
Heating system during lithium battery charging	No Yes and not customized
Operator identification device	No Card reader
Lifting electronic limit	No Yes and not customized
Hydraulic control	Joystick Fingertip
Rear armrest horn	Yes and not customized
Area Speed Limit System	No Yes and not customized
Weighing system	No Yes and not customized
Wiper water unit	Yes only with Cabin
Automatic Parking Brake	Yes and not customized
Height display+Forward tilt speed limit+High-position lateral shift speed control	No Yes and not customized
Surround View System+Human recognition system	No Yes and not customized (NON-CE)
Automatic fork leveling	No Yes and not customized