

JMA[®]



MÁQUINA DUPLICADORA KEY CUTTING MACHINE

MULTICODE

V.04



www.jma.es

KEY CUTTING MACHINE
MULTICODE
USER MANUAL

1.- PRESENTATION AND GENERAL ASPECTS	57
1.1 GENERALITIES	57
1.2 TRANSPORT AND PACKAGING.....	57
1.3 IDENTIFICATION LABEL.....	57
2.- INSTALLATION AND CHARACTERISTICS OF THE MACHINE	58
2.1 MAIN ELEMENTS OF THE MULTICODE	58
2.1.1 Multicode.....	58
2.1.2 Tablet support and tablet	58
2.1.3 Power unit and power cable	60
2.2 INSTALLATION	62
2.3 MACHINE DESCRIPTION	62
2.4 FAMILY AND TERMINOLOGY OF KEYS.....	63
2.5 TECHNICAL DATA.....	64
2.6 ACCESSORIES BOX.....	65
3.- CLAMPS.....	66
3.1 CLAMP FOR FLAT KEYS.....	66
3.1.1 Use of the standard clamp "MP1".....	66
3.1.2 Special clamps.....	68
3.2 CLAMP FOR POINTS AND CHANNEL KEYS.....	70
3.2.1 The clamp.....	70
3.2.2 Type of limit	70
3.2.3 Jaw model	71
3.3 ADJUSTMENT OF DIFFERENT CLAMPS.....	72
3.3.1 Adjust the clamps, flat keys	72
3.3.2 Adjust safety clamp	73
4.- COPY OF A KEY.....	75
5.- USE OF THE TABLET	76
5.1 CHARGING AND STARTING THE TABLET.....	76
5.2 CHOOSE LANGUAGE.....	76
6.- CLEANING AND SAFETY.....	78
7.- MAINTENANCE	78
7.1 ACCESS TO THE REAR PART.....	79
7.2 CONTROL REPLACEMENT	79
7.3 CLEAN SWARF TRAY AREA.....	80
7.4 REPLACE PRISMATIC CUTTER.....	80
7.5 REPLACEMENT CYLINDRICAL CUTTER.....	81
7.6 REPLACEMENT TRACER.....	81
8.- WASTE ELIMINATION.....	82
8.1 PACKAGING.....	82
8.2 SWARF.....	82
8.3 MACHINE.....	82
9.- SERVICE	83
10.- SOFTWARE OPERATIONAL GUIDE	83
10.1 BLUETOOTH LINK	84
10.2 CHANGE OF LANGUAGE	86
10.3 KEY SCALE 1:1.....	86
10.4 SEARCHES.....	88
10.4.1 Searches by lock manufacturer (Standard Areas).....	88
10.4.2 Search by automation, by type, by brand, model and year (Automation Area).....	91
10.4.3 Search for keys by equivalents with another manufacturer (Equivalents Area).....	92
10.5 CUTTING INFORMATION (FILE).....	93
10.5.1 Toothed key files.....	93
10.5.2 Point key file	97
10.5.3 Channel / Slot key File.....	100
10.6 JAW SETTINGS.....	102
10.6.1 Adjust Toothed Jaw.....	103
10.6.2 Points/Channel jaw adjustment	103
10.7 UPDATE FIRMWARE.....	104
10.8 DIAGNOSTICS	106

1.- PRESENTATION AND GENERAL ASPECTS

1.1 GENERALITIES

The MULTICODE duplicating machine has been designed taking into account current safety regulations in force in the E.E.C.

Personal safety involved in the use of this type of machine is only attained with a well designed programme for personal safety, like the implementation and following of the recommended suggestions as well as compliance with the safety regulations contemplated in this manual.

Although the installation of the machine is not difficult, we recommend carefully reading this manual before trying to install, adjust or handle the machine.

The machine has left our factory ready for use and only needs calibrating operations for the tools to be used.

1.2 TRANSPORT AND PACKAGING

The machine is inside a package with the following dimensions:

Width = 610 mm, length = 510 mm, height = 520 mm.

Machine weight plus packaging = 32 Kg.

When unpacking the machine, carefully inspect it to see if it has been damaged during transport. If you discover any anomaly, immediately notify the transporter and do not do anything with the machine until the transporter agent has made the corresponding inspection.

1.3 IDENTIFICATION LABEL

The MULTICODE duplicating machine has an identification label (Fig. 1), indicating the serial or registration number of the machine, name and address of the manufacturer, EC marking and year of manufacturing.

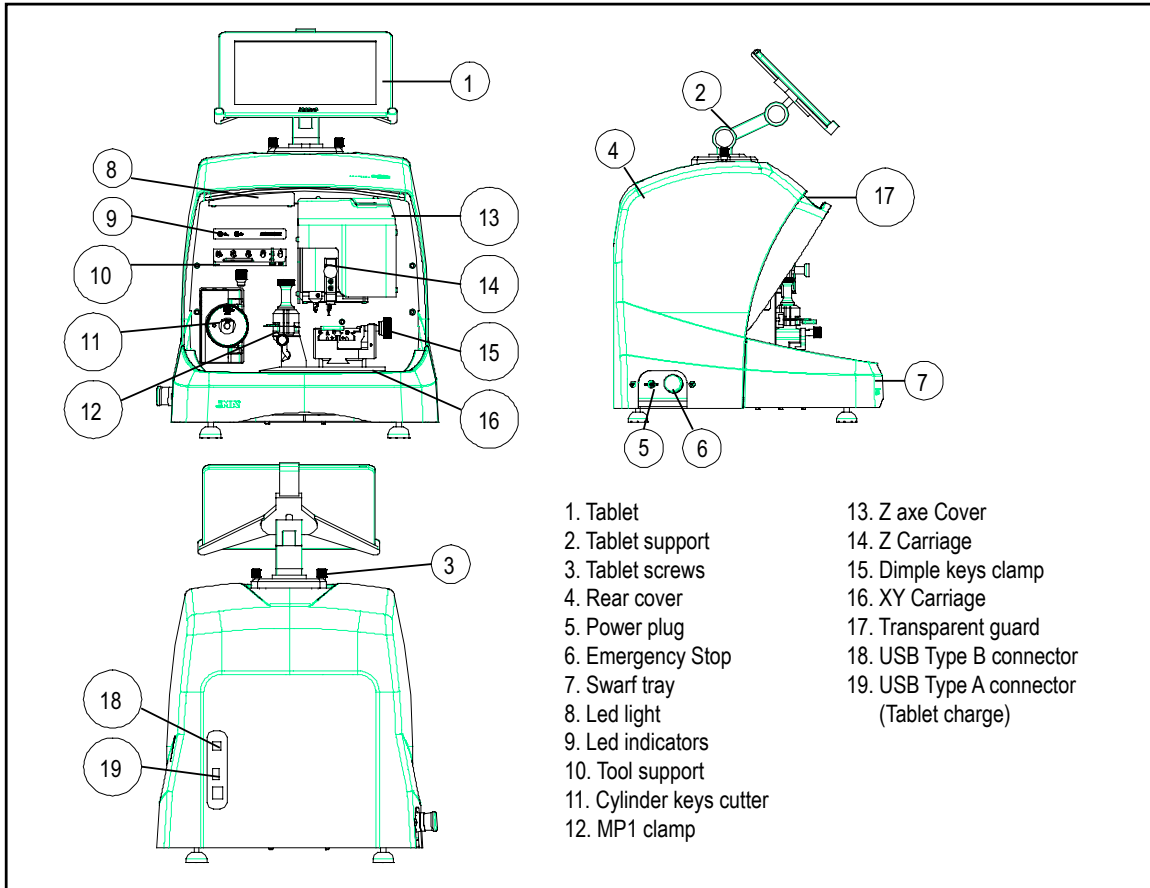

FIG. 1

2.- INSTALLATION AND CHARACTERISTICS OF THE MACHINE

2.1 MAIN ELEMENTS OF THE MULTICODE

2.1.1 MULTICODE



2.1.2 TABLET SUPPORT AND TABLET

The following components are separately packaged in the box of the machine:

- Tablet support and tablet

These two components should be installed on the machine as follows (Fig. 2):

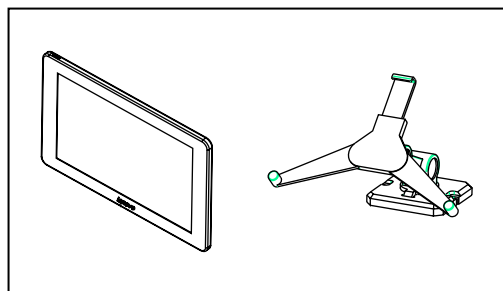

FIG. 2

1. Unthread the knobs (T1) located on the machine. (Fig. 3)
2. Install the tablet support.
3. Thread and tighten the knob to fix the tablet support on the top part of the machine.
4. Introduce the tablet into the support.

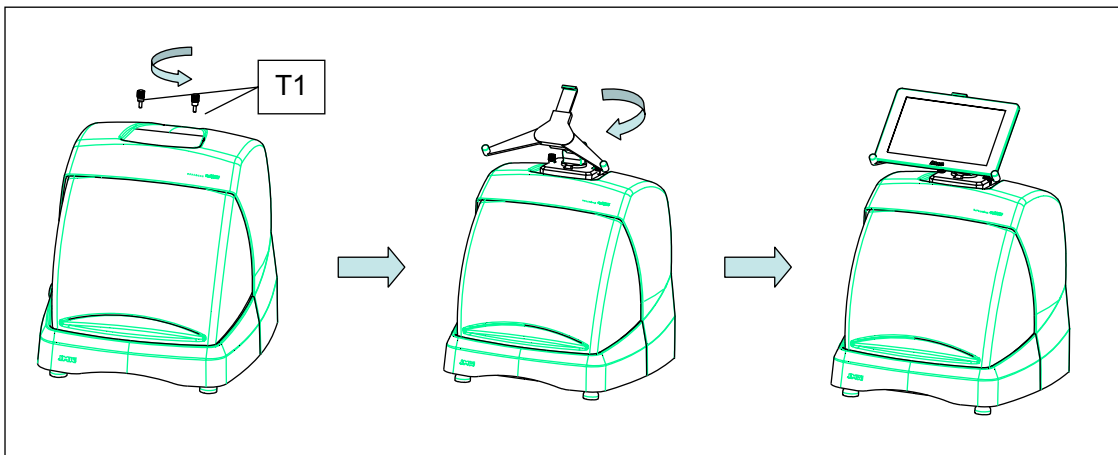

FIG. 3

- Use and settings of the tablet support

The tablet support has different settings:

1. Height setting of the upper clamp. Turning the lever (A) clockwise, you can adjust the height of the clamp (B) to introduce the tablet. After adjustment, block it by turning the lever anticlockwise. Clamps (C) and (D) are adjusted to adapt to the size of the tablet.

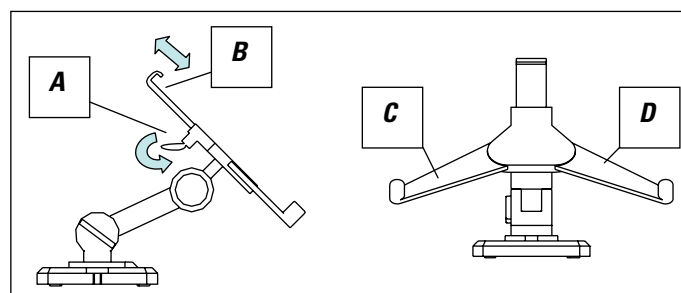

FIG. 4

2. Height setting of the tablet support (E) Turning knob (F) anticlockwise, adjusts the height of the tablet clamps. After adjustment, block knob (F) by turning it clockwise.

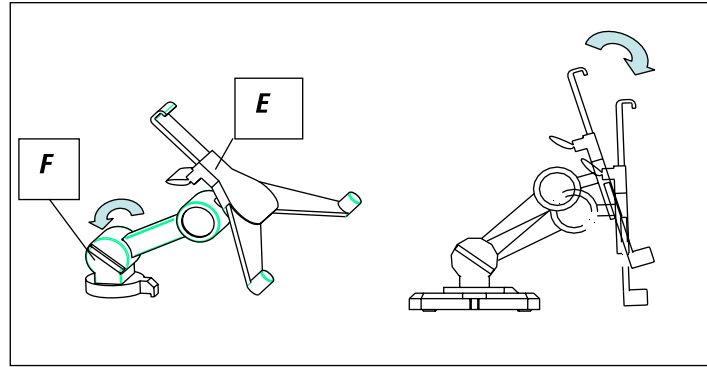

FIG. 5

3. Turning the tablet support (E). Unlocking the clamp (F), you can turn the tablet support. After setting the position, block it again.

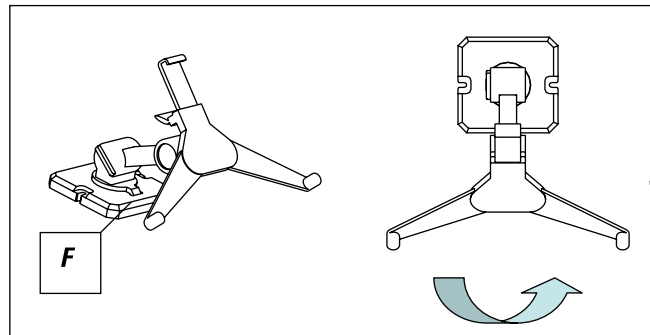

FIG. 6

2.1.3 POWER UNIT AND POWER CABLE

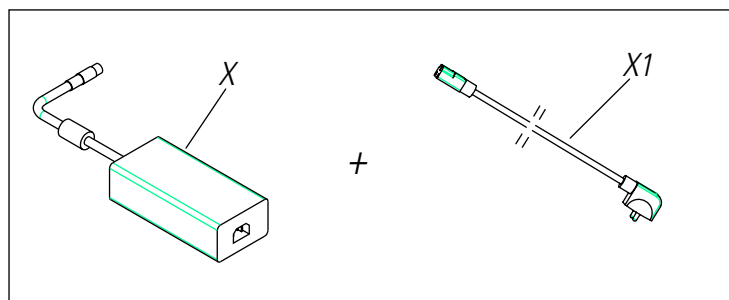

FIG. 7

Connect the MULTICODE to the power unit (X) and connect this latter to a power outlet using the power cable (X1).

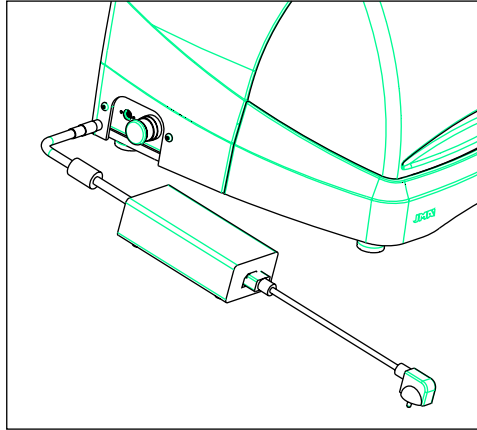

FIG. 8

Note: Connect the 24V DC 4 pin connector with the flat face looking downwards.

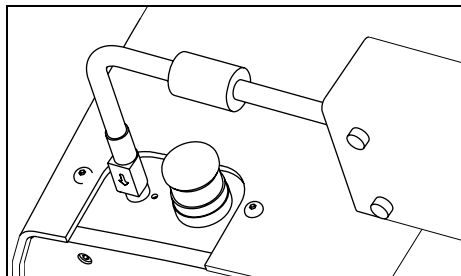

FIG. 9

2.2 INSTALLATION

The machine is assembled, calibrated and controlled ready for use and does not need any assembly operations. In all cases, before the first start-up, the following controls should be made:

- Connect the MULTICODE machine to adequate voltage power supply (220V 50Hz or 110V 50/60 Hz) using the supplied power unit (See section 2.1.3)
- It is very important that the electrical installation of the establishment has an earth connection. Make sure that the machine is connected to earth.

After having unpacked the machine and connected the supplied cable to the power outlet, the machine is ready for use.

Make sure the emergency button is not pressed, if it is, unblock it.

After starting the machine, the carriages will move to the start position (if they are not there already) and a green light will show on the display. (Fig. 10)

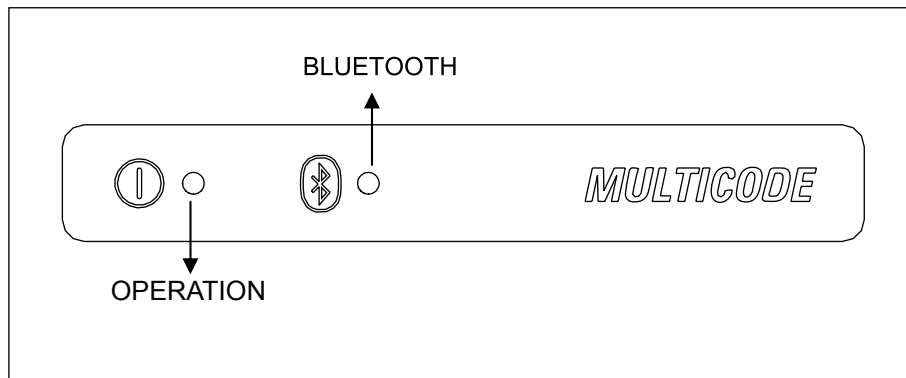

FIG. 10

The MULTICODE machine, will only work if it is connected to the TABLET with the JMAKeyPro program. The communication between the software and the machine is via Bluetooth.

This said, switch the tablet on and then activate the software. After having activated the program, a blue light will show on the display. (Fig. 10) The machine is now prepared to operate.

2.3 MACHINE DESCRIPTION

The MULTICODE machine has been designed to cut flat, points/channel type keys. During the design phase, the minimal details have been analysed to manufacture a compact machine, easy to use and that is very precise. This is a Mecatronics machine, with three stepper motors for displacement of the carriages.

In other words, we are before a very versatile machine that can be used for both flat, pointed or channel keys.

It reads and/or decodes flat keys with standard coding and point/channel keys using a feeler with electronic contact.

2.4 FAMILY AND TERMINOLOGY OF KEYS

The MULTICODE machine duplicates the following types of keys:

- Flat (A) and vehicle (B) type keys.
- Point (D), channel / groove (vehicles) (E) type keys.

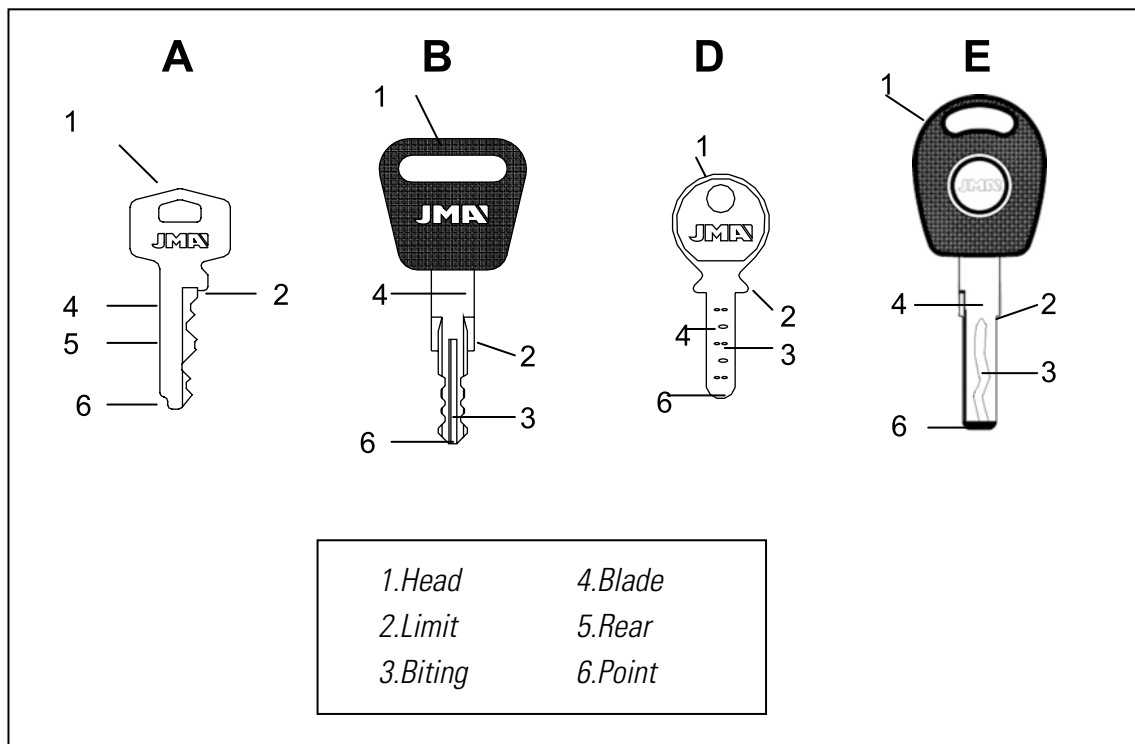

FIG. 11

2.5 TECHNICAL DATA

The main technical data is shown below:

Power supply

24V d.c.-7.5 Amp.-180W
Power unit: 100/240V a.c.- 50/60HZ-180W

Cutter Prismatic (Flat keys)

High speed steel. Turning speed 1100 rpm

**Cutter Cylindrical
(Point/channel or groove keys)**

Hardened steel. Turning speed 12000 rpm

Standard jaw (MP1) for flat keys

With four sides

Jaw for dimple/channel keys

With interchangeable jaws

Displacement

With flexball (ball screw) activated by stepper motors on rectified roller guides.

Tool tracks

X= 45mm..

Y= 45mm.

Z= 30mm.

Illumination

LED diode

Dimensions

Depth: 413mm

Width: 427mm

Height with support + tablet: 612mm

Height without support + tablet: 431mm

Tablet

Mass

27Kg.

2.6 ACCESSORIES BOX

The MULTICODE machine is equipped with a box for accessories for maintenance and settings (Fig. 12). The accessories are as follows:











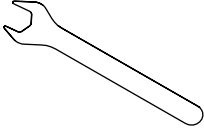

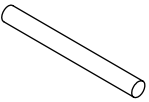
<p>Spanner 18 mm DX-69</p> 	<p>Allen key 2mm EC-19</p> 	<p>Allen key 5mm DX-75</p> 
<p>Cutter blocking rod Ø4x30 MC-118</p> 	<p>Allen key 2.5mm DX-78</p> 	<p>Fuse: T6.3A 250V MC-133</p> 
<p>Brush DX-154</p> 	<p>Allen Key in 'T' 3 mm DK-338</p> 	<p>Adjustment lever CRG CRG</p> 
<p>Point limit set DX-181</p> 	<p>Allen key 4mm DX-76</p> 	<p>03F Cutter 3F</p> 
<p>01F Cutter 1F</p> 	<p>Jaw setting tracer RP RP</p> 	<p>Jaws C and D MC-114/MC-115</p> 
<p>2F Cutter 2F</p> 	<p>Adjustment plate RPC RPC</p> 	<p>Pen AVN-259</p> 

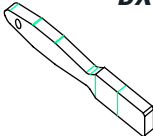
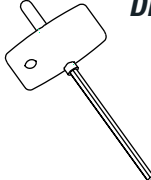
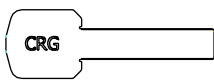
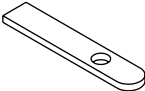
FIG. 12

3.- CLAMPS

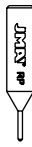
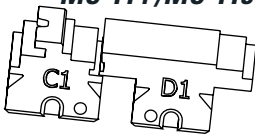
The machine consists of two clamps, one for machining flat keys and another for point and/or channel keys. The use of the two clamps for correct operation is detailed below.

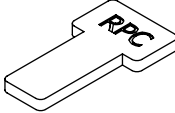
3.1 CLAMP FOR FLAT KEYS

3.1.1 USE OF THE STANDARD CLAMP "MP1"

The standard clamp "MP1" is designed for reading and machining flat keys. When attaching the key, consider two aspects: Side and key limit.

- Sides 1, 2, 3 and 4 of the standard clamp "MP1".

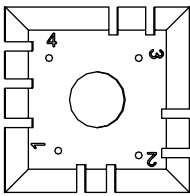

The standard clamp has 4 sides, (numbers engraved on the top part of the clamp) that allow closing the attached keys on the rear and profile. The clamp is designed to hold different models of keys. The side change is simple, leave the clamp slightly open, and manually turn the key to the desired side.

The different sides and characteristics of the key to be attached are indicated below:

- Copying a key with rear support.
 - Side 1: keys with normal blade
 - Side 2: keys with narrow blade
- Copying of keys by means attaching the key by its profile
 - Side 3: Key with guide in lower part
 - Side 4: Key with guide in upper part

Representation of standard clamp with images of different attaching (Fig. 13)

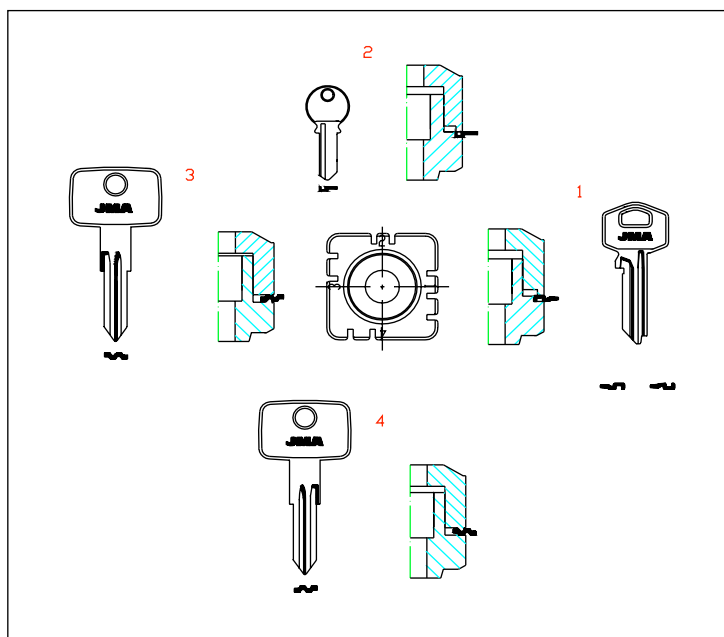

FIG. 13

- Key limit.

After having chosen a side of the clamp, then you have to position the key lengthwise, to do that you have to take into account the limit of the key. Depending on the model of the key, there are two types of limit:

1. Neck limit (C): This is the most common. The key is limited by means of a mechanical limit of the clamp. (Fig. 14)

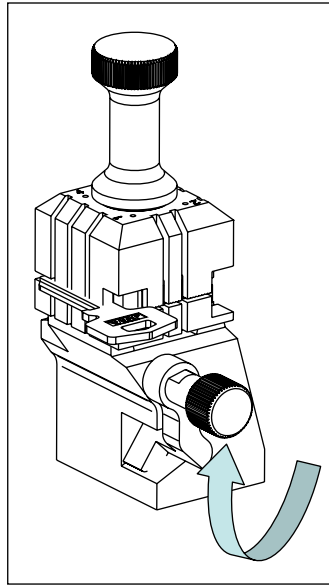

FIG. 14

2. Point limit (1, 2, and 3): The key is limited by means of the point limit supplied in the accessory box and this is placed together with the key in the standard clamp slot.

Example of key positions in side 1 and limit 2 (Fig. 15)

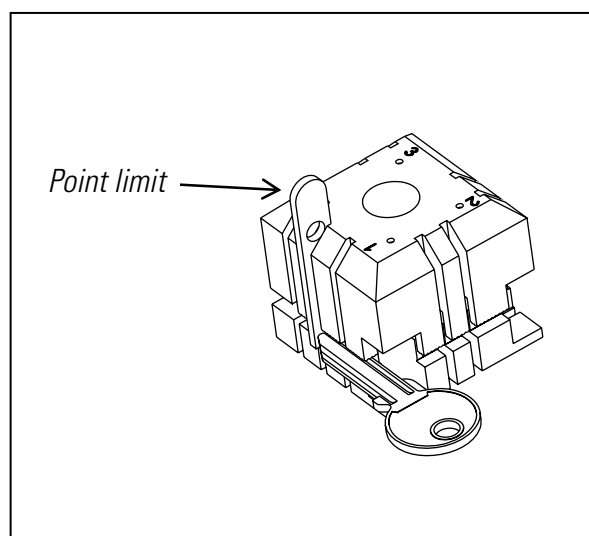

FIG. 15

Image of a clamp with the numbering of the slots to make the limits. (Fig. 16)

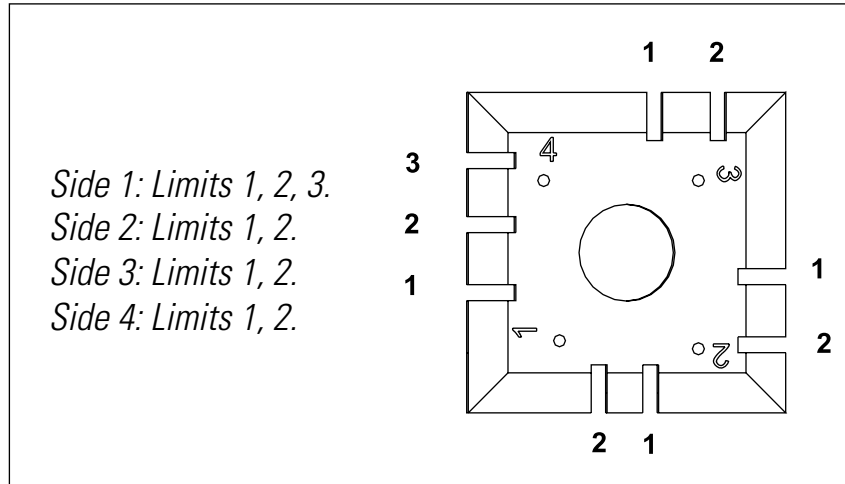

FIG. 16

All the necessary information about attaching the key from the **JMAKeyPro** software in the tablet will appear when the key code is introduced.

3.1.2 SPECIAL CLAMPS

• MP1-RS8

Clamp RS8 has 4 sides to duplicate the following key models (Fig. 1):

- Side 1: Key with normal bit (Standard).
- Side 2: RS8 model key.
- Side 3: Key with guide on the bottom.
- Side 4: Key with guide on the top.

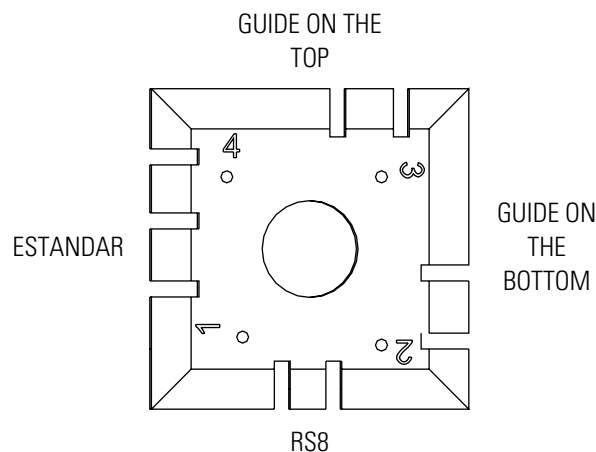

• MP1-D12

Clamp ASSA D12 has 4 sides to duplicate the following key models:

- Side 1: Key with normal bit (Standard).
- Side 2: Key with narrow bit (Standard).
- Side 3: Key with guide on the bottom and top.
- Side 4: ASSA D12 key model.

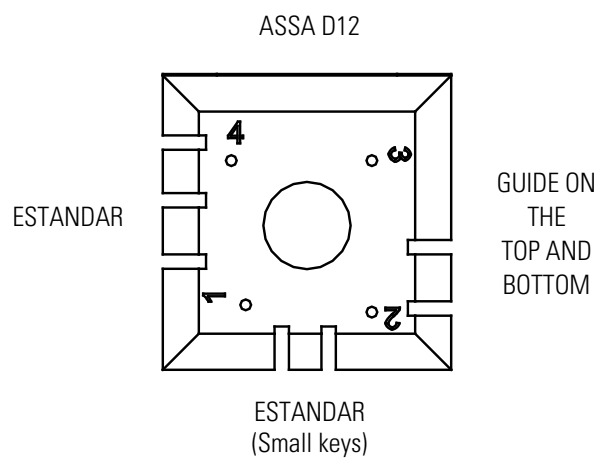

• MP1-ABP

Clamp ABUS –PFAFFENHAIN has 4 sides to duplicate the following key models:

- Side 1: Key with normal bit (Standard).
- Side 2: Key with narrow bit (Standard).
- Side 3: V14 Y14 model key.
- Side 4: W14 model key (Wavy Line).

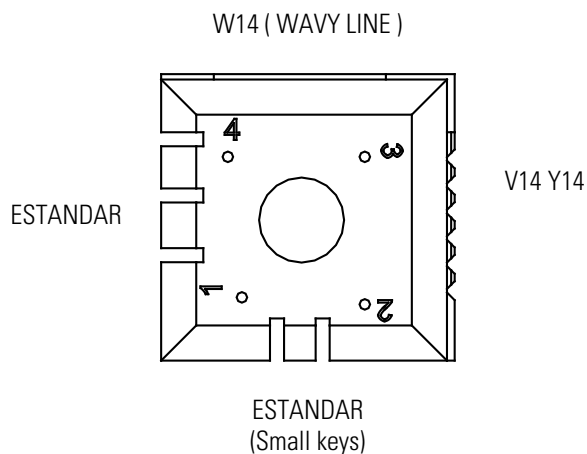

3.2 CLAMP FOR POINTS AND CHANNEL KEYS

According to the key to be machined or coded, follow the indications that appear in the JMAKeyPro software in the tablet. The main indications refer to the following:

3.2.1 THE CLAMP

It indicates which model of clamp you should use.

Both point and channel keys can be introduced into the clamp. In the case that the clamp has to be removed, follow these steps:

- 1) Raise the transparent guard.
- 2) Loosen screw (T2) and remove the clamp by moving it toward the operator.
- 3) Introduce the clamp (previously cleaning the housing) into the dovetail and raise it to the top.
- 4) Lock the clamp by turning screw (T2).

FIG. 17

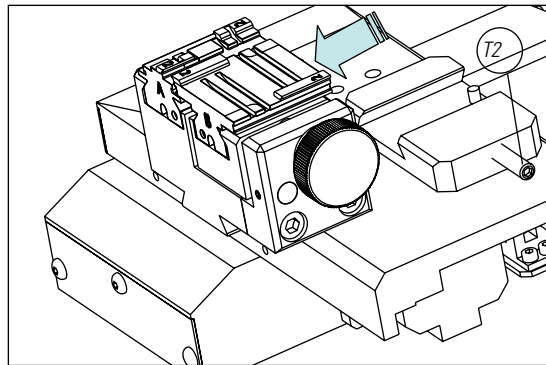

3.2.2 TYPE OF LIMIT

Both point and channel keys can be introduced into the clamp, with neck limit or with point reference. The first (with C limit) have to be supported against the jaws while the others (point limit) have to be supported with reference in one of the channels (1-2-3), as indicated in the JMAKeyPro software. For this operation use the point limit that is in the accessory box, after having positioned the key, remove it.

- Neck limit

FIG. 18

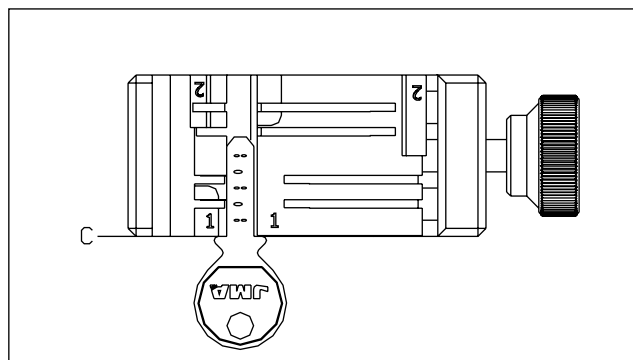

- Point limit (1-2-3)

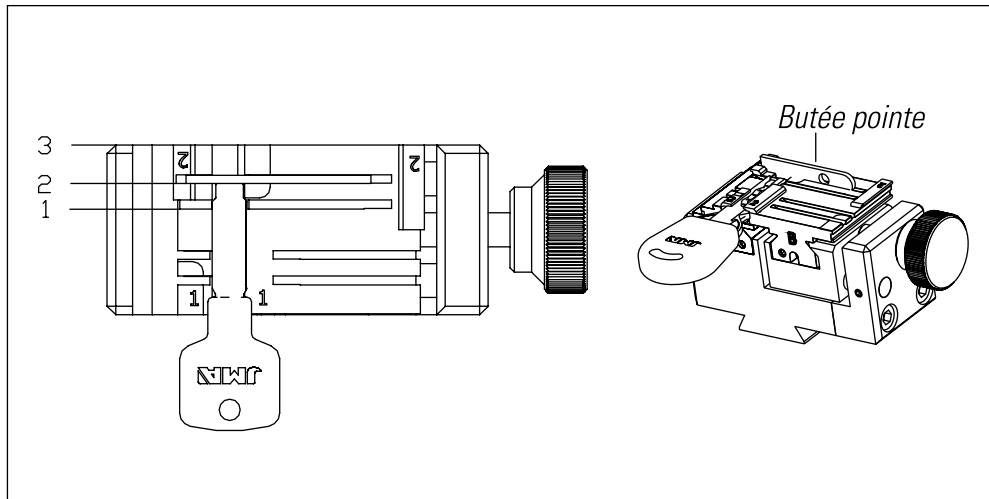

FIG. 19

3.2.3 JAW MODELS

The clamp has two standard jaws, a fixed one (A) and a mobile one (B). One of the important characteristics of the jaws is that they have two sides to attach different models of keys. Both the fixed jaw and the mobile one, have two sides, 1 and 2.

The following steps are to change the jaw or the side of the jaw:

- 1) Unscrew the knob (T3) to the end
- 2) Push the jaw(s) with your fingers from its rear part removing it towards the operator. (Fig. 20)
- 3) Clean the jaw housing area with the brush.
- 4) Change the jaw of the side and fully introduce it.

FIG. 20

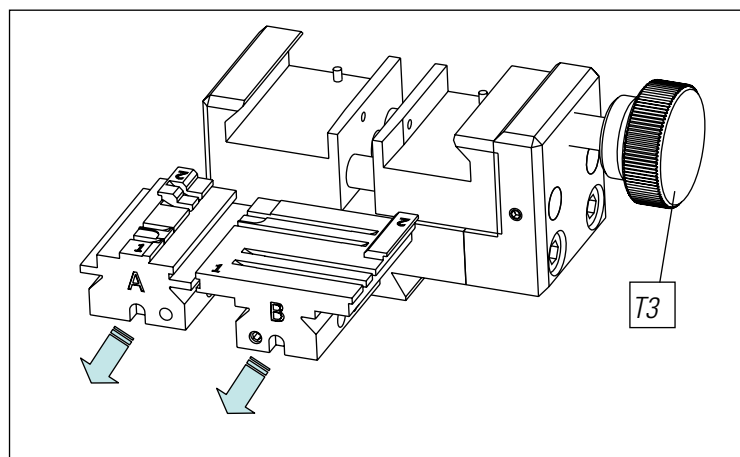

Note: The information about the jaws to be used appears in the **JMAKeyPro** software in the tablet.

3.3 ADJUSTMENT OF DIFFERENT CLAMPS

The machine has different areas (flat and safety) to adjust the clamps and take readings.

3.3.1 ADJUST THE CLAMPS, FLAT KEYS

This can be used both for adjusting the cutter or the reader. After adjustment, it can be used to take key readings.

The following steps are for adjusting the cutter:

- 1) Place the CRG (T4) in the clamp MP1 on side 1.(Fig.21)

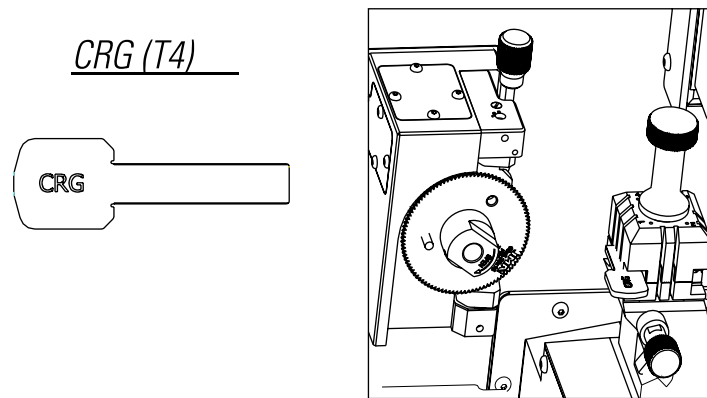

FIG. 21

- 2) Go to the SETTINGS menu, select settings -> adjust zero-machines (flat key) -> Cutter.
- 3) Select the clamp and then press the cutter adjustment button.

To adjust the reader of flat keys.

- 1) Place the CRG (T4) in the clamp MP1 on side 1.(Fig.21) (Fig. 22)
- 2) Place the tracer in the testing position by turning the axis (T5)

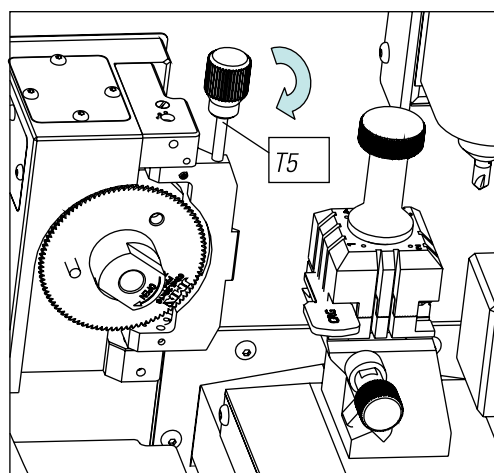

FIG. 22

- 3) Go to the **SETTINGS** menu, select settings -> adjust zero-machines (flat key) -> Reader.
- 4) Select the clamp and then press the reader adjustment button.

To take readings of flat keys:

1. Place the flat key in the corresponding side of the clamp MP1.
2. Place the tracer in the testing position by turning the axis (T5)

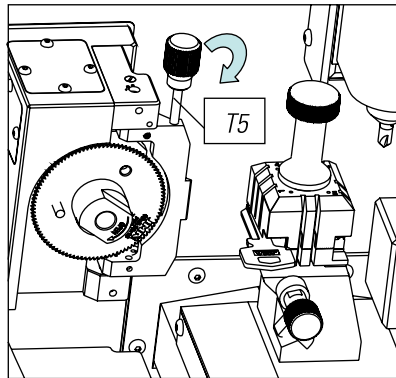

FIG. 23

3. In the technical specification of the key, press the key reading button.

3.3.2 ADJUST SAFETY CLAMP

3.3.2.1 RP TRACER

The RP tracer is used to adjust the cutter, it should be used when changing the jaws or the clamps. Follow these steps:

- 1) Place the RP tracer on the cutter support (T6)
- 2) Fix the tracer turning the 3 mm Allen key (T7)
- 3) Position the RPC adjustment plate in the clamp, from the back side of the clamp (Fig.24).
- 4) Go to the **SETTINGS** menu, select settings -> adjust zero-machines (safety key) -> Cutter.
- 5) Select the clamp and then press the cutter adjustment button.

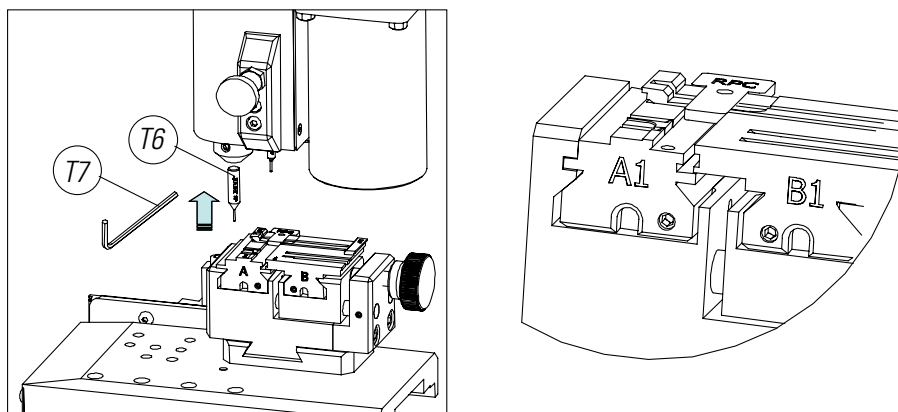

FIG. 24

3.3.2.2 TRACER 1P

The 1P tracer is used to adjust the reader and to code the point or channel keys.

To adjust the reader:

- 1) Remove the lever (T8) and let it drop to its position.
- 2) Position the RPC adjustment plate in the clamp, from the back side of the clamp (Fig.25).
- 3) Go to the SETTINGS menu, select settings -> adjust zero-machines (safety key) -> Reader.
- 4) Select the clamp and then press the cutter adjustment button.
- 5) After having performed the cycle, return the tracer to its rest position.

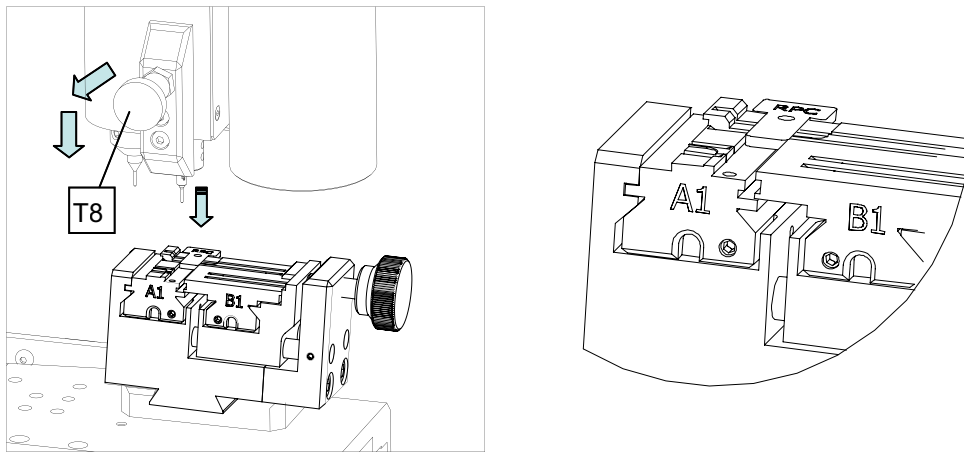

FIG. 25

To code point or channel keys

- 1) Remove the lever (T8) and let it drop to its position.
- 2) In the technical specification of the key, press the key reading button.

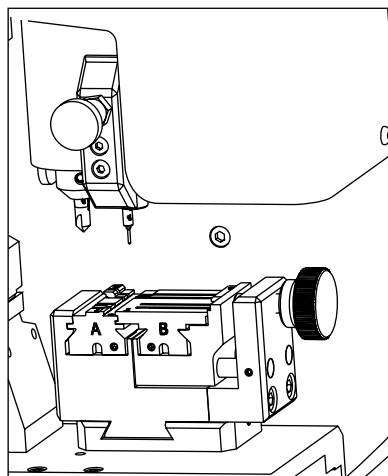

FIG. 26

4.- COPY OF A KEY

This option is used to make a copy of a key when no information about it can be found (model, file, etc.). The key reading process is based on electrical contact. **It is therefore very important for the feeler and the key to both be clean, with no burrs.**

Follow the steps below:

1. Open the transparent protective shield.
2. Place the key to be copied in clamp MP1.
3. Move the feeler to the testing position by rotating the axis.
4. Open the menu and select the copy of a copy reading option. The depth (X) and lateral (Y) values can be adjusted.

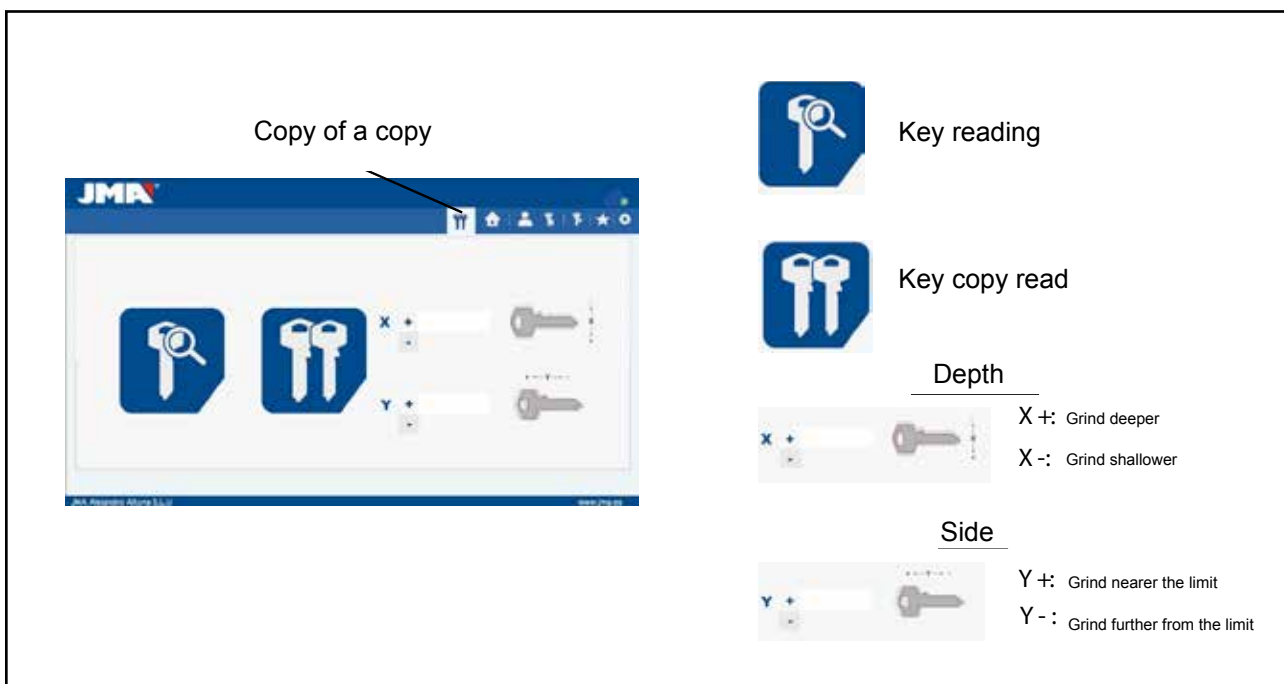

Once the key has been read,

1. Return the feeler to its initial position.
2. Remove the key that has been read and insert a key blank.
3. Close the transparent protective shield.
4. Select the read copy option.

(Please note: it is not possible to read anodised aluminium keys, plastic keys or keys made from other non-conductive materials).

5.- USE OF THE TABLET

The tablet, USB/micro USB cable and power plug are separately packed inside the box of the machine.

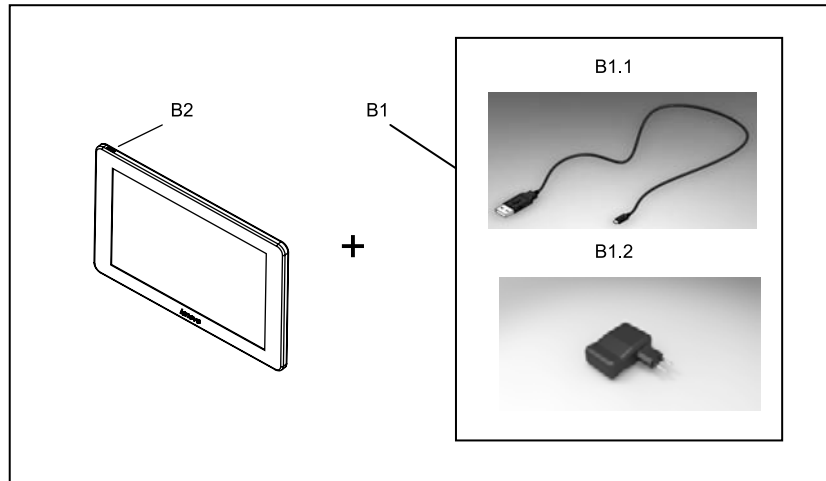

FIG. 27

5.1 CHARGING AND STARTING THE TABLET

It may be necessary to charge the battery before using the tablet . Two ways to charge the battery:

- 1) Connecting the power supply (B1) of the tablet to 220V mains.
- 2) Connecting the USB/microUSB (B1.1) to the machine. (SEE 2.1.1)

The first time the tablet is connected, a complete charge should be made.

Switch the tablet on, by pressing the corresponding button for a few seconds (B2).

5.2 CHOOSE LANGUAGE

- 1) Select "Settings".



2) Select "Language and text introduction".

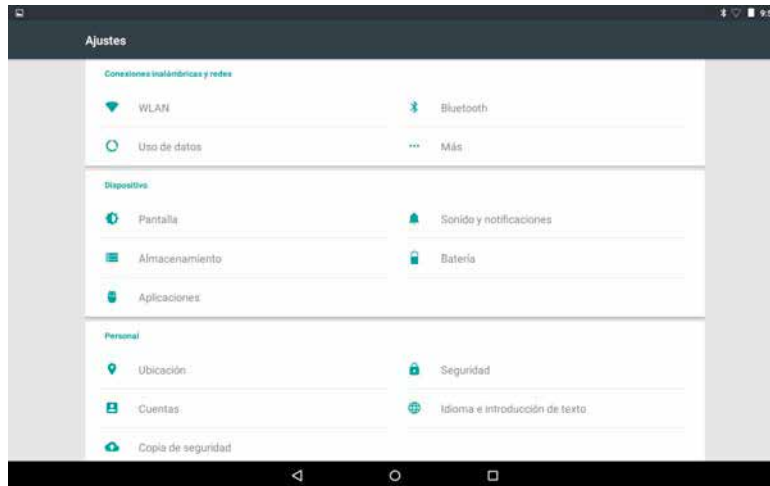

3) Select "Language".

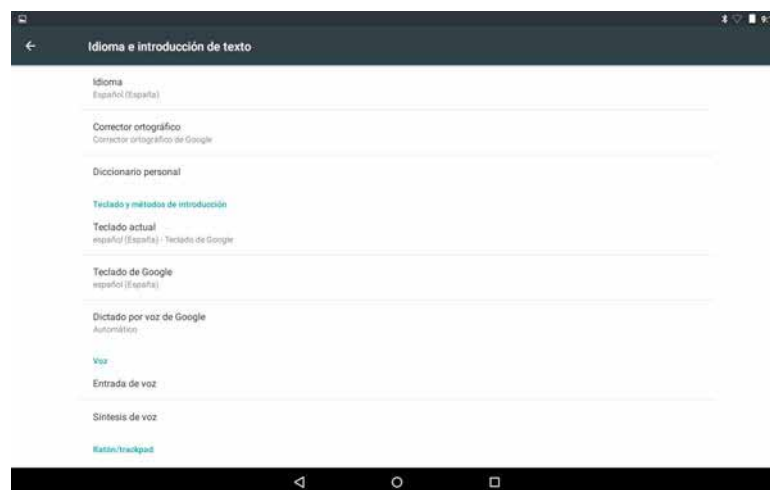

4) Move down the menu and select your language.

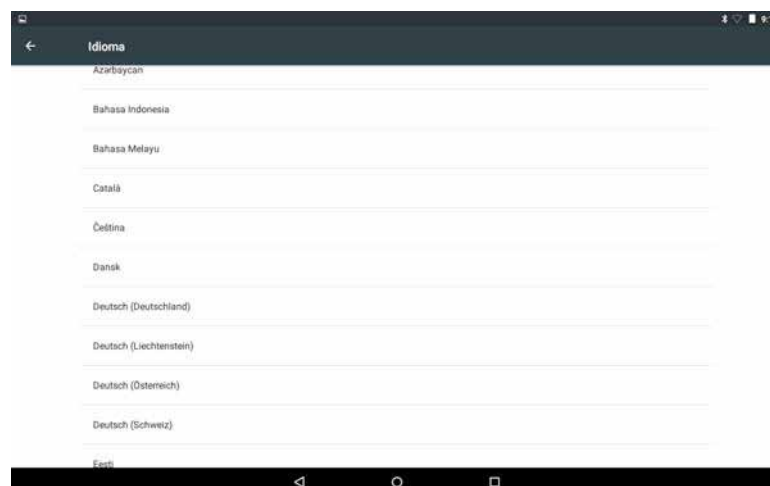

5) To finish, press the circle.



Note: For all the MULTICODE functions, follow that indicated in the JMAKeyPro software and in the manual.

For all other indications, follow that indicated the quick guide of the tablet.

6.- CLEANING AND SAFETY

We recommend following these guidelines for the cleaning:

- Maintain all functional parts of the machine as clean as possible, removing with the brush all machining swarf.
- Never use compressed air to clean the work area of swarf, this could enter the operational parts.

We recommend following these guidelines for your safety:

- Do not try to start or manipulate the machine until all safety measures, installation instructions, operator guide and maintenance procedures have been completed and understood.
- Always disconnect from the power supply, before performing any cleaning or maintenance.
- Work with dry hands.
- Make sure the machine is earthed.

7.- MAINTENANCE

Before starting any type of maintenance operation, the following requirements should be completed.

- You should never carry out any operation while the machine is running.
- You should disconnect the cable from the power supply.
- The indications in the manual should be strictly followed.
- Only use original spare parts.

The machine does not need any special maintenance, only revise and if applicable, replace worn pieces, for example, cutters, jaws, feelers...

Note: Use lubrication products, for preventive maintenance of the machine. Avoid the product from making contact with electronic parts.

7.1 ACCESS TO THE REAR PART

To have access to the rear part, you should do the following:

- 1) Switch the machine off using the emergency stop and disconnect the cable from the power supply.
- 2) Remove the Tablet from the support.
- 3) Release 7 screws (T10) with a 3mm Allen key (Fig. 28)

Note: Do not touch the zinc-plated screws

- 4) Remove the rear guard (T11) moving it upwards.

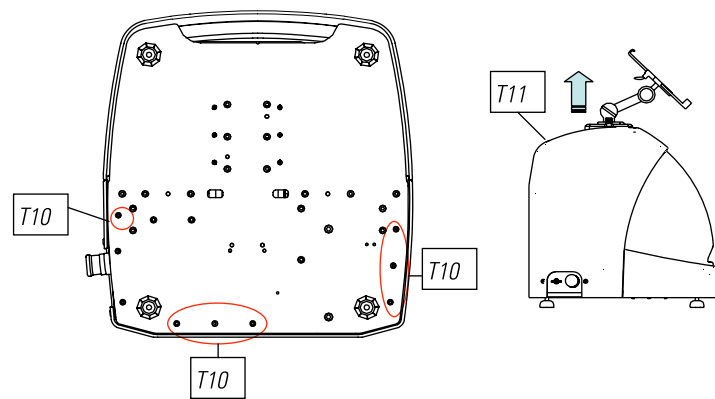

FIG. 28

7.2 CONTROL REPLACEMENT

To replace the control, follow these steps:

- 1) Remove the rear guard. (See 6.1)
- 2) Remove the cables connected to the control.
- 3) Release the two screws (T12) with a 5mm Allen key (Fig. 29)
- 4) Replace the control.
- 5) Re-assemble all the components again.

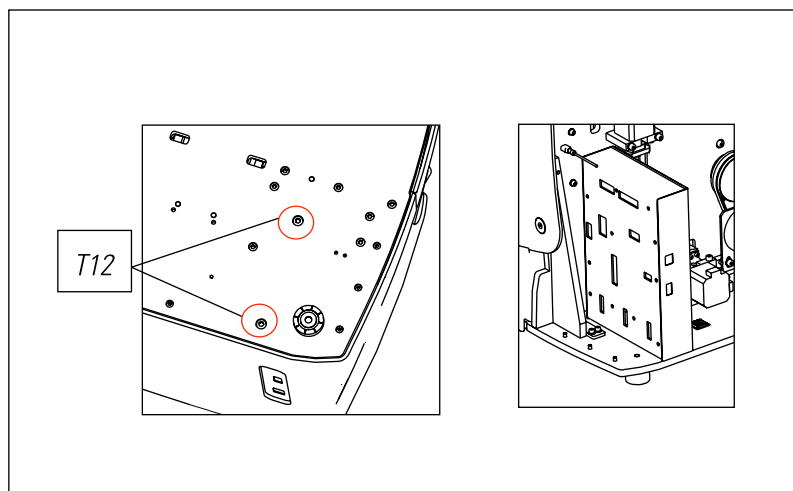

FIG. 29

7.3 CLEAN SWARF TRAY AREA

To remove the swarf tray, do the following:

- 1) Remove the swarf box, pulling it outwards.
- 2) Remove the swarf, using the brush.
- 3) Re-introduce the tray taking it to the bottom following the two lines (T13) marked in black on the chassis (Fig. 30)

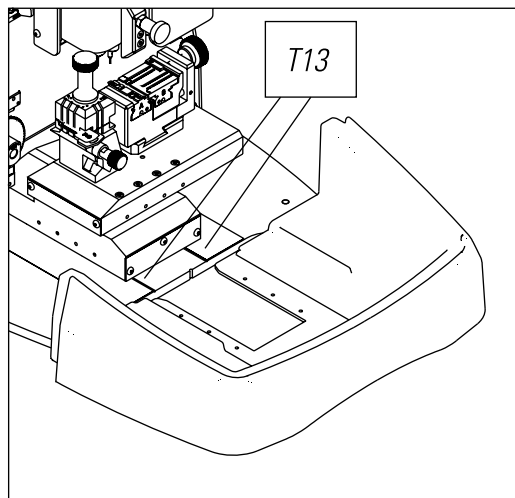

FIG. 30

7.4 REPLACE PRISMATIC CUTTER.

To replace the cutter, do the following:

- 1) Switch the machine off using the emergency stop and disconnect the cable from the power supply.
- 2) Raise the front plastic guard.
- 3) Introduce the blocking rod (T14), which is in the accessory box (Fig. 31)
- 4) Unscrew the cutter fixing screw (T15) with the 18mm spanner.

Note: Thread to the left

- 5) Replace the cutter, block the nut, remove the rod from the hole and place the protection cover.

NOTE: In the case of installing a new cutter, the cutter will have to be adjusted

(See sect. 3.3.1)

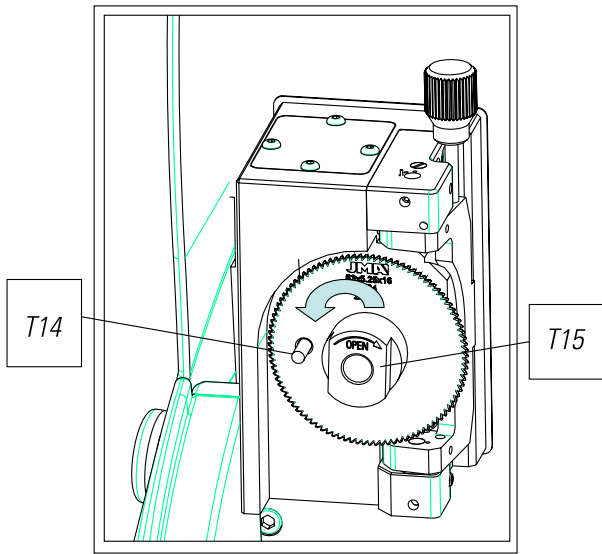

FIG. 31

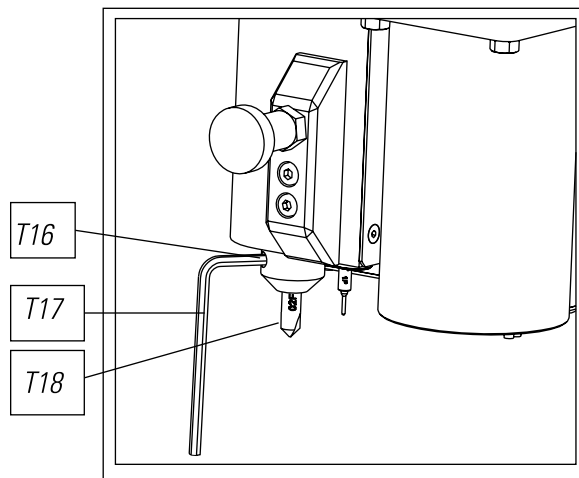

FIG. 32

7.5 REPLACEMENT CYLINDRICAL CUTTER

- 1) Switch the machine off using the emergency stop and disconnect the cable from the power supply.
- 2) Raise the front plastic guard.
- 3) Unscrew the prisoner screw (T16) with a 3mm spanner (T17) and remove the cylindrical cutter (T18). Fig. 32
- 4) Replace the cutter, pushing upwards to the limit.
- 5) Tighten the prisoner screw. (T16)

7.6 1P FEELER REPLACEMENT

- 1) Switch off the machine using the master switch and unplug the power cord.
- 2) Raise the front plastic shield.
- 3) Loosen the holder (T19) using a 2 mm Allen key (T20) and remove the 1P feeler (T21). Fig. 33
- 4) Replace the feeler, pushing it in as far as it will go.
- 5) Tighten the holder. (T19)

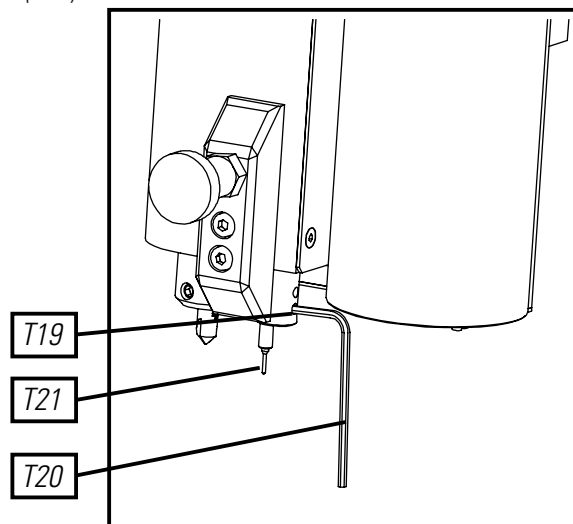
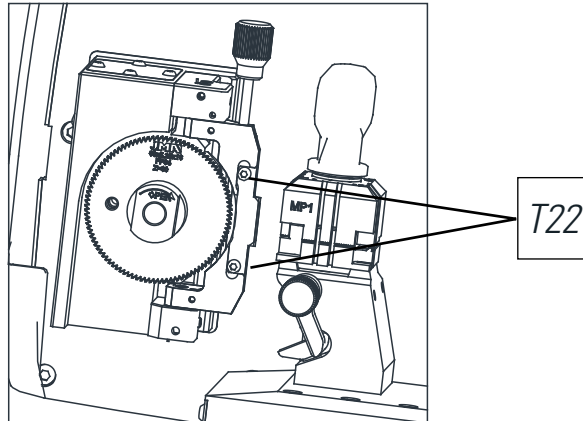

FIG. 33

7.7 REPLACEMENT TRACER.

- 1) Switch the machine off using the emergency stop and disconnect the cable from the power supply.
- 2) Raise the front plastic guard.
- 3) Unscrew the two screws (T22).
- 4) Replace the tracer and tighten again the screws.

FIG. 34



(NOTE: In the case of installing a new tracer, the tracer will have to be adjusted) (see section 3.2.1)

8.- WASTE ELIMINATION

Waste is understood to be any substance or object originating from human activities or natural cycles, abandoned or designed to be abandoned.

8.1 PACKAGING

- Because the packaging of the MULTICODE machine is made from cardboard, it can be recycled as packaging.
- As waste, it is classified as solid urban waste and therefore can only be deposited in special containers for cardboard.
- The moulds that protect the machine inside the cardboard box, are made from polymer also classified as solid urban waste and therefore, can only be eliminated in normal installations for the elimination of solid waste.

8.2 SWARF

- The residues originating from the copying of key are classified as special waste, but are included in the group of solid urban waste, for example like a metal washing pad.
- This waste is eliminated according to the classification of the laws in force in the EU, and should be taken to the special waste elimination companies.

8.3 MACHINE

- Before scrapping the machine, it should be put out of service, cutting the power supply and separating the pieces of plastic from the pieces of metal.
- After doing this, all the waste can be eliminated, according to the laws in force in the country where the machine is used.

9.- SERVICE

Alejandro Altuna has a technical service for all clients of the MULTICODE machine.

To assure complete safety for the operator and the machine, any work not indicated in this manual, should be carried out only by the manufacturer or technical service. If there is any doubt about handling the machine, consult the address indicated at the end of this manual.

10.- SOFTWARE OPERATIONAL GUIDE

The JMAKeyPro software is used for the complete control of the Multicode machine. To access this software you only have to press the icon.



After executing the program, we have the following main menu.

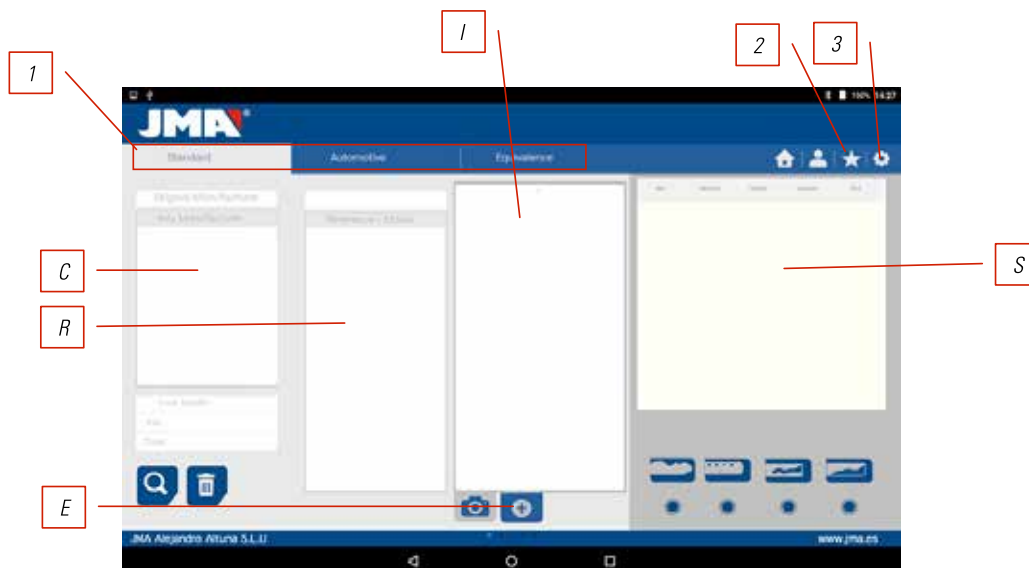

1) The program is divided into 3 different areas according to the type of search required.

- Search by manufacturers of locks.
- Search by automation, by type, by brand, model and year
- Search for keys by equivalents with another manufacturer

2) Favourites Here we can find the series of commonly used keys that we have stored as favourites.

3) Settings

The program always shows us the image (I) of the blank key, information of the lock manufacturer (C), references (R) of blank keys manufacturer, additional information like references of equivalents (E) of other manufacturers of keys and lastly we have information related to the series (S) assigned to that manufacturer or key model, according to as the search is made.

10.1 BLUETOOTH LINK

The Multicode machine comes with a Tablet, with the application so the Multicode can function, but the JMAKeyPro application can be installed in any Tablet with a screen of 8" or more and with Android 4.4.2 "Kitkat" or later. In the case of changing the Tablet, and using another Tablet to control the Multicode, first you will have to couple the Tablet and the Multicode machine. To do that, proceed as follows. Switch on the Multicode machine and see if the green diode comes on steady, this means that the machine is initialized and ready. Make sure the Bluetooth diode is not on, this means that the machine is already connected to a Tablet and therefore it cannot be coupled to another Tablet. If the blue Bluetooth diode is off, we can continue with the coupling.

- Enter into the settings section (A) of the Android Tablet.

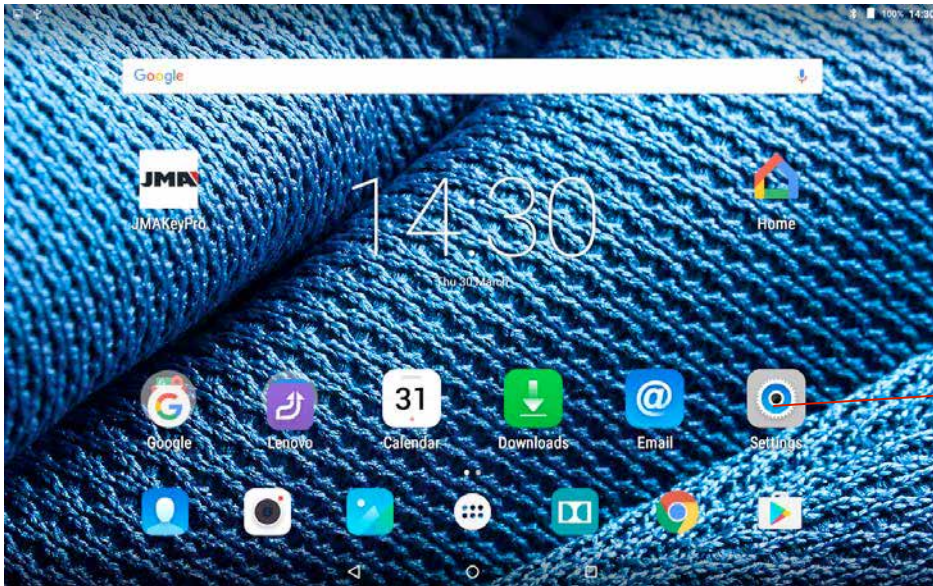

- In settings, we go to Bluetooth (B) in the section of wireless connections and networks:

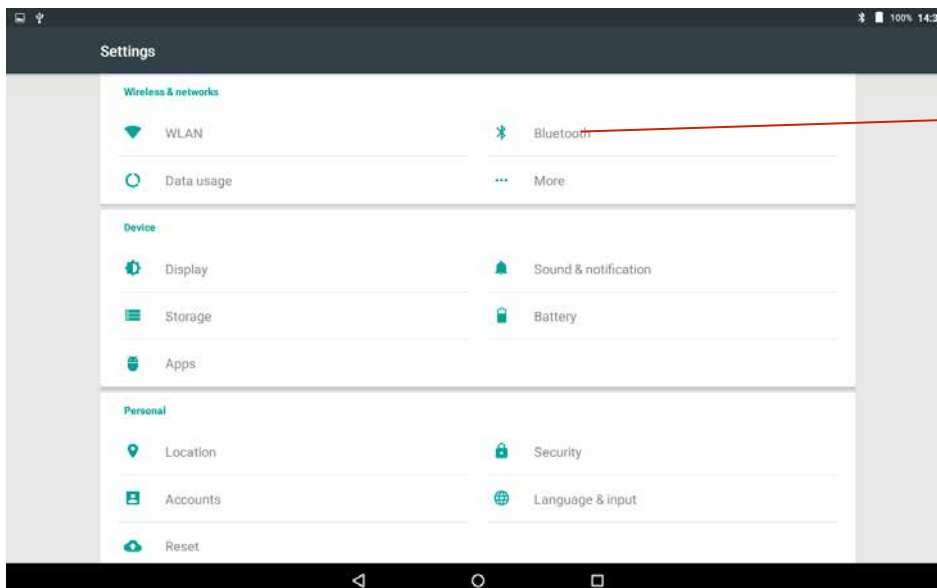

In the next screen of Bluetooth devices, we assure that the Bluetooth of the Tablet is activated, so we can search all the devices within its reach, (the scope is 15 metres, without any type of obstacle, if there is an obstacle this scope is reduced). Search for the Bluetooth device named "JMA Multicode".

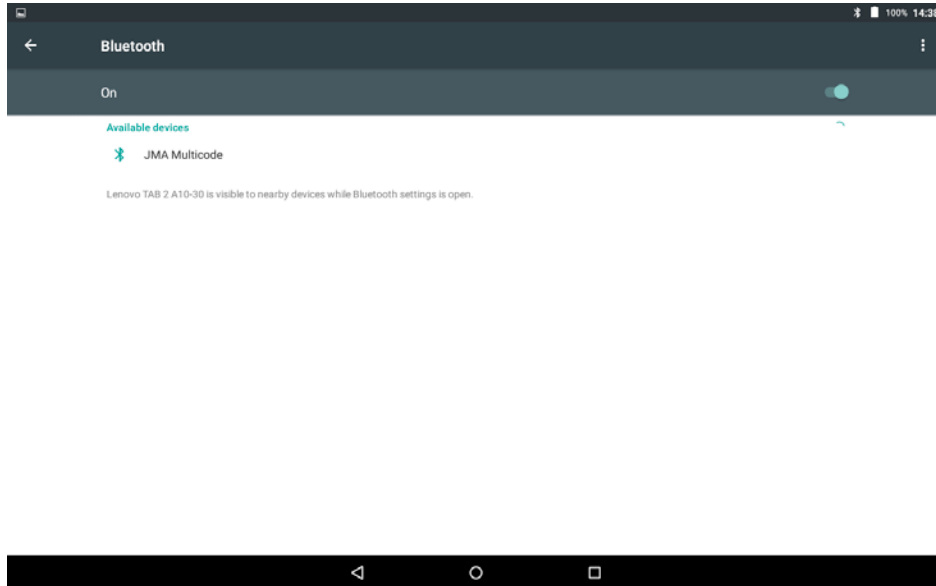

After choosing the device we will see the message of "Coupling Device" on the screen, it is an automatic process, there is no need to introduce any code or password for coupling. After the coupling process has finalized "JMA Multicode" should appear in "Synchronized Devices".

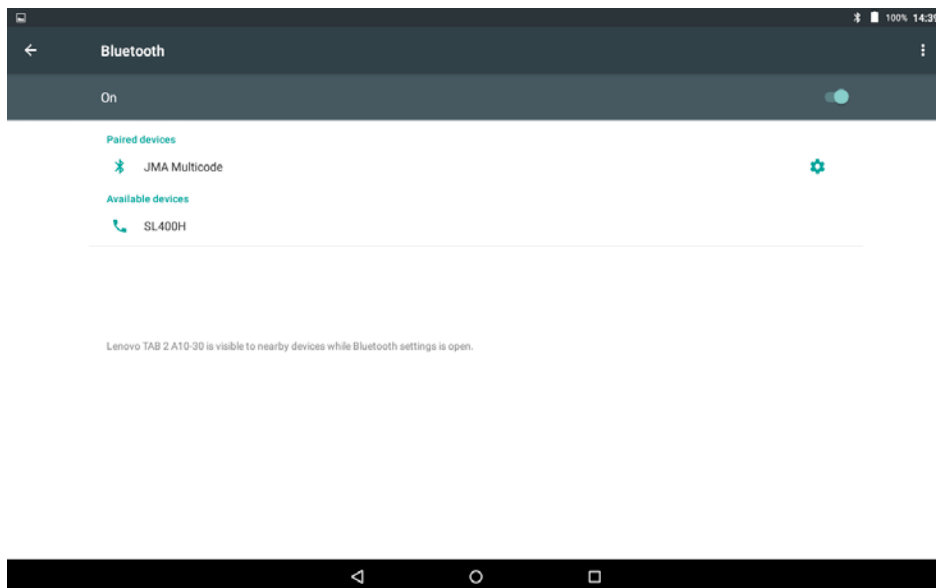

Once we have "JMA Multicode" in synchronized devices, we can enter the "JMAKeyPro" application and once we enter the application, after a few seconds, the blue connection diode of the machine will come on to indicate that the communication between the program and Multicode is re-established.

10.2 CHANGE OF LANGUAGE

The language can be changed in the "JMAKeyPro" program, to do that go to the settings section.

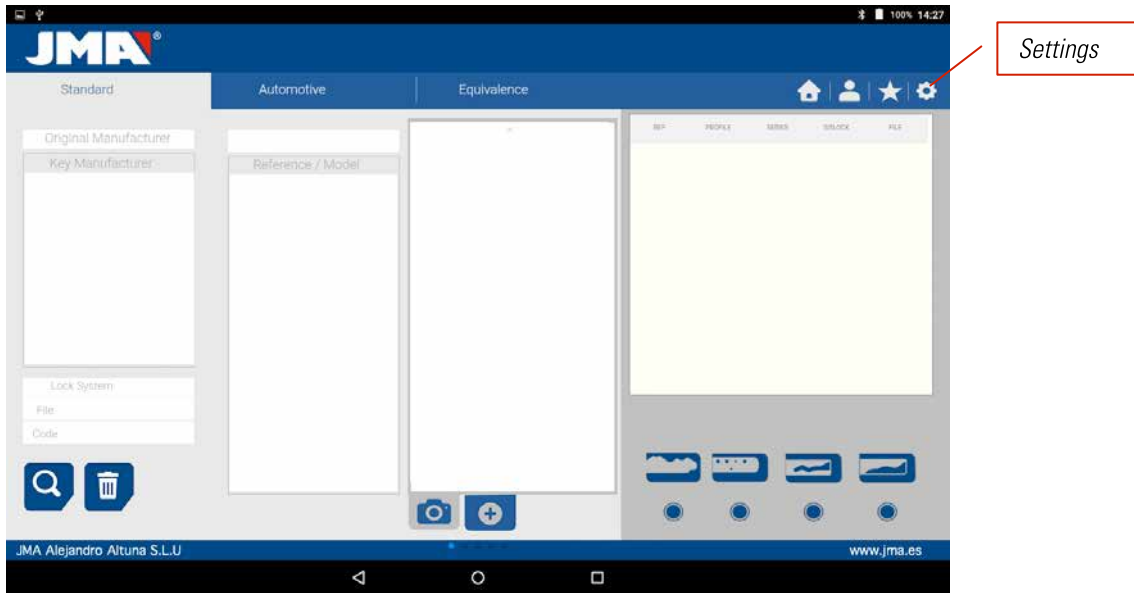

In settings, we choose the language in which we want the program to work and wait for the language to appear automatically.

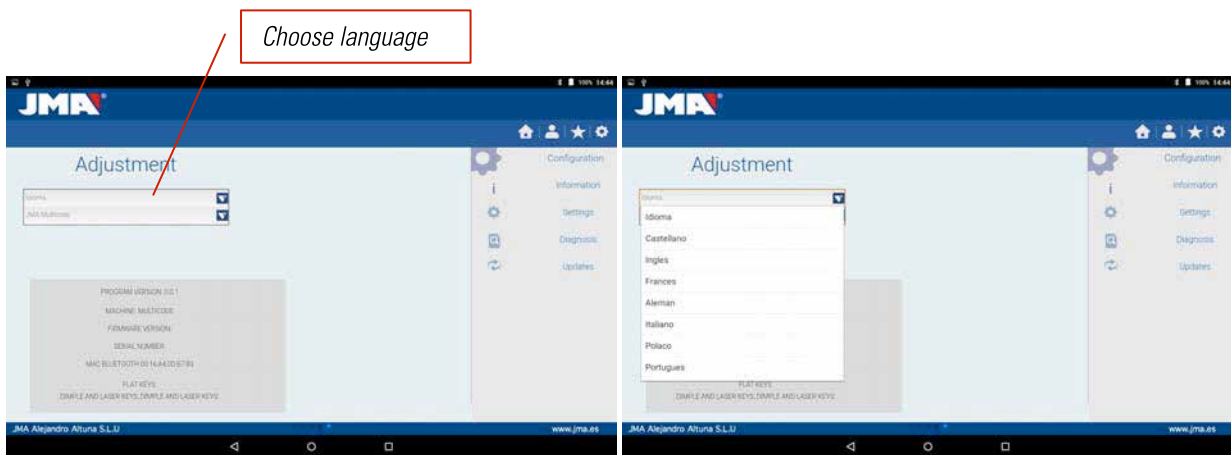

10.3 KEY SCALE 1:1

The program allows us to see the key in scale 1:1 at any time during a search, this allows us to check the physical key we have on the image generated by the program at 1:1 scale. To obtain the image of the key at 1:1 scale, click or touch the image of the key (1).

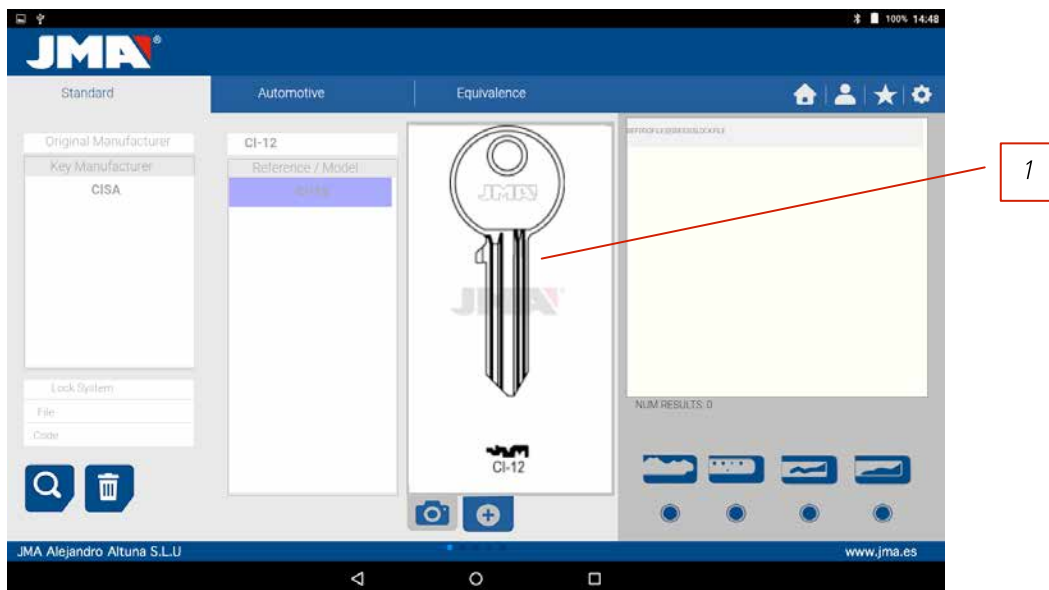

After pressing on the image a window appears on the screen with the 1:1 scale image of the key. This window has the peculiarity that the entire screen is no sensitive to the touches by the hand or the key, which allows us to position the physical key over the 1:1 scale image. The only area sensitive to touch is the cancel button (C) that allows us to return to the main search menu.

NOTE: Remember that the image of the main menu is not 1:1 scale and depends on the size of the Tablet screen, while after pressing the image you will obtain a 1:1 scale image.

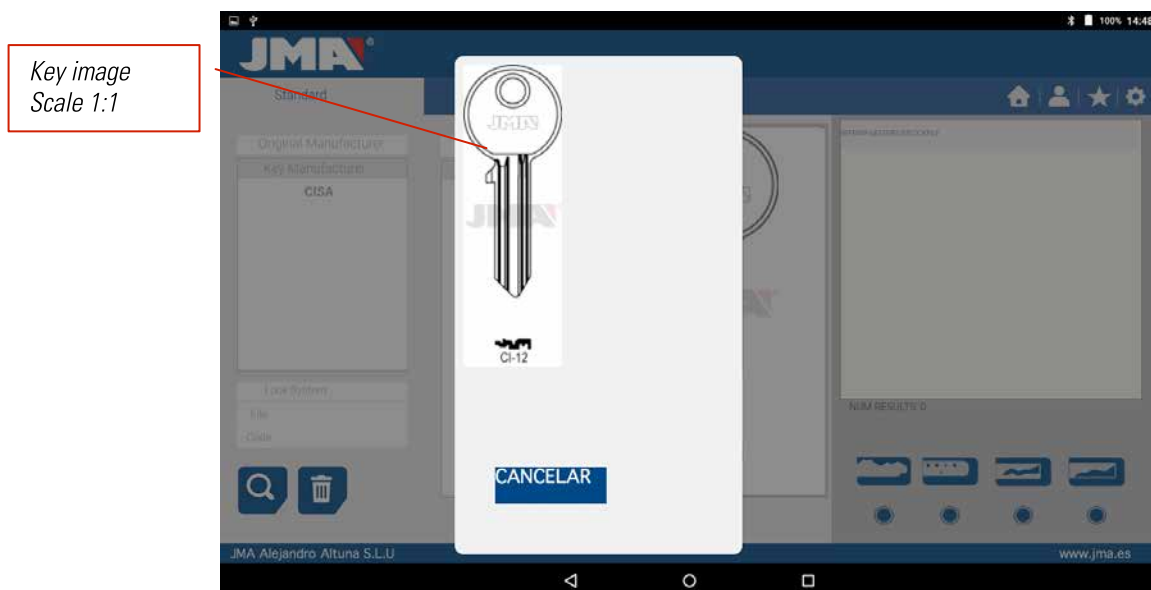

10.4 SEARCHES

10.4.1 SEARCHES BY LOCK MANUFACTURER (STANDARD AREAS)

This screen is the most versatile because it allows us to make different types of searches according to the criteria we choose. We are going to define the different types of searches we can perform.

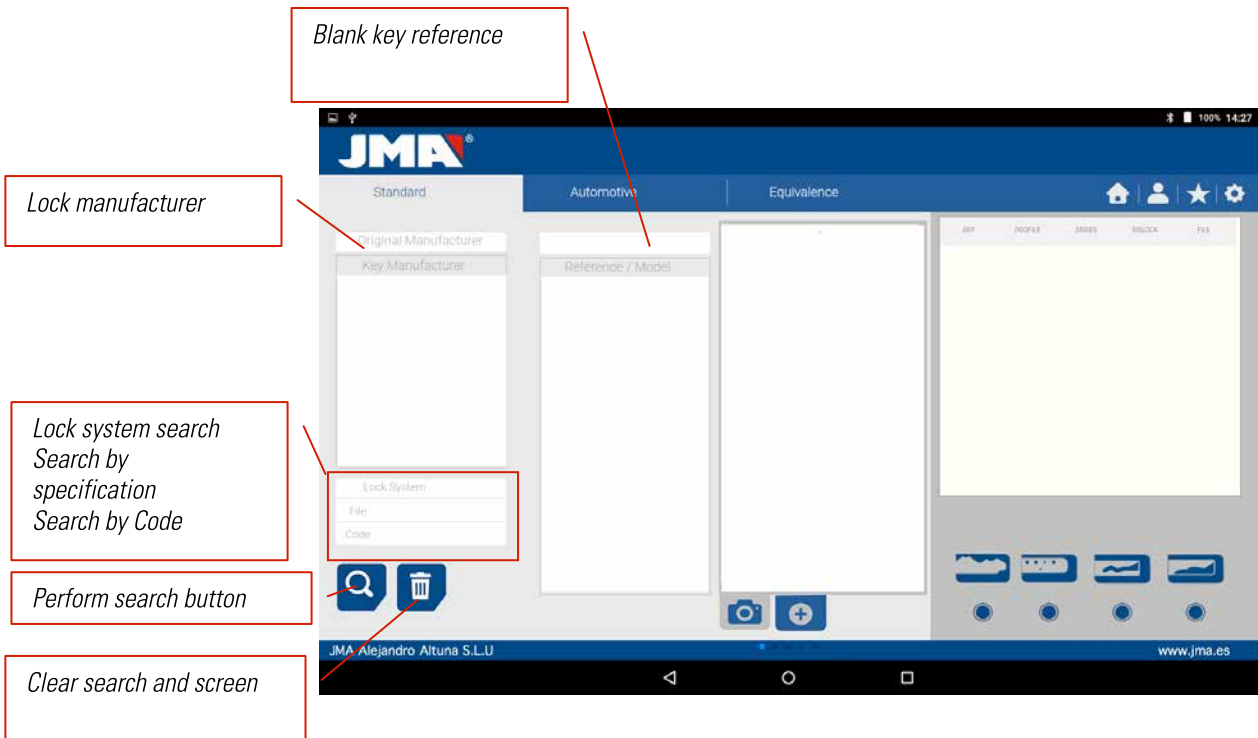

Case 1: The most general search is introducing the lock manufacturer and press search.

When we enter or select a lock manufacturer, the system makes an automatic search. The search is made by introducing the name into the box corresponding to manufacturer search, as we type the letters, the system will filter the possible manufacturers with those letters.

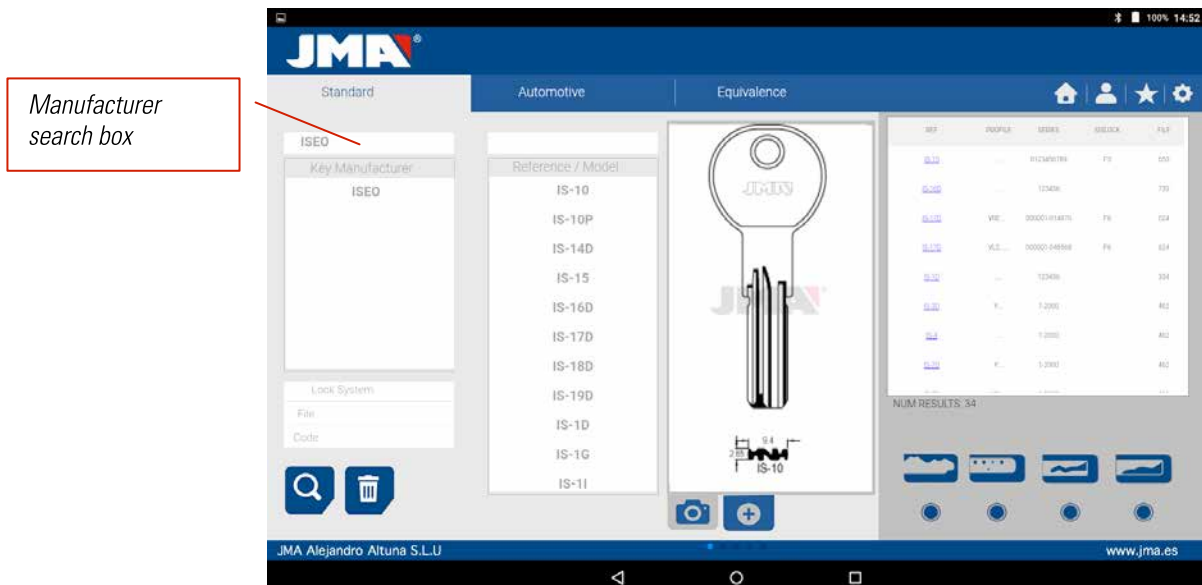

Case 2: Define a JMA key blank and see, which the series, related to that key is.

When we enter or select a JMA key reference, the system makes an automatic search. The search is made by introducing the name into the box corresponding to the JMA blank key reference, as we type the letters, the system will filter the possible manufacturers with those letters.

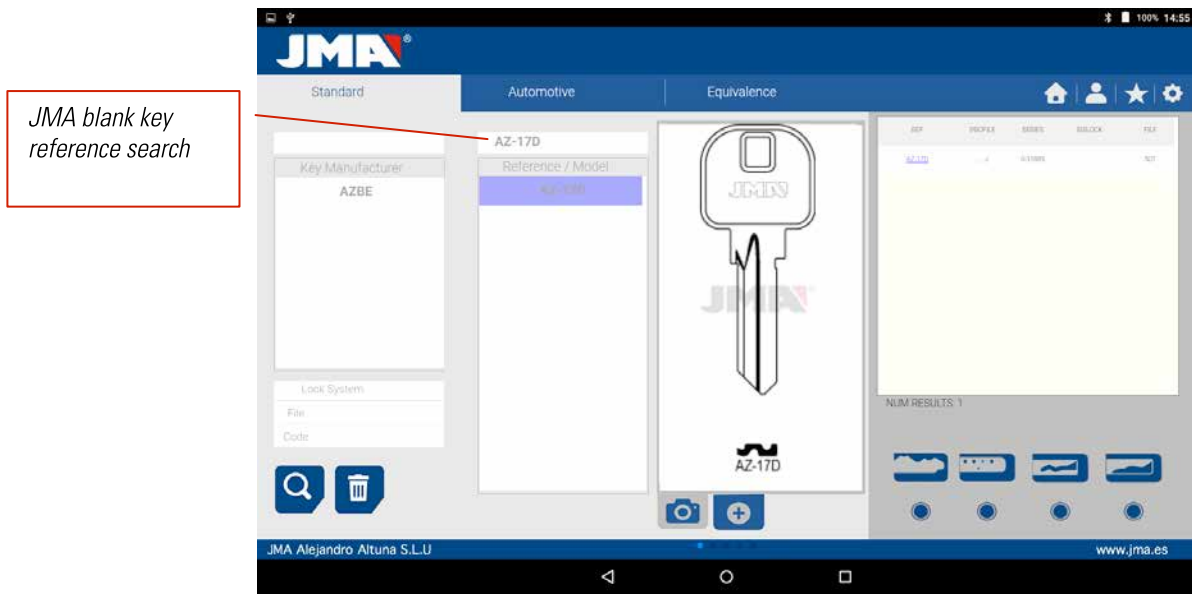

Case 3: The lock system is defined in the software, introduce part of this name and press search. This search will give you all the possibilities containing that word.

In the search by lock system, we should press the search button (F) to make the search and later press the erase button (D) to make any other search with another word.



Case 4: Directly search for a file we want to use for machining.

This search for the series that contain the exact file we have introduced in the file search box.

In the search by lock system, we should press the search button (F) to make the search and later press the erase button (D) to make any other search with another word.



Case 5: In the case we have the key code, either the direct or the indirect code, we can make a search by only introducing the code.

This searches the series that coincide with the code of the key.

In the search by lock system we should press the search button (F) to make the search and later press the erase button (D) to make any other search with another word.

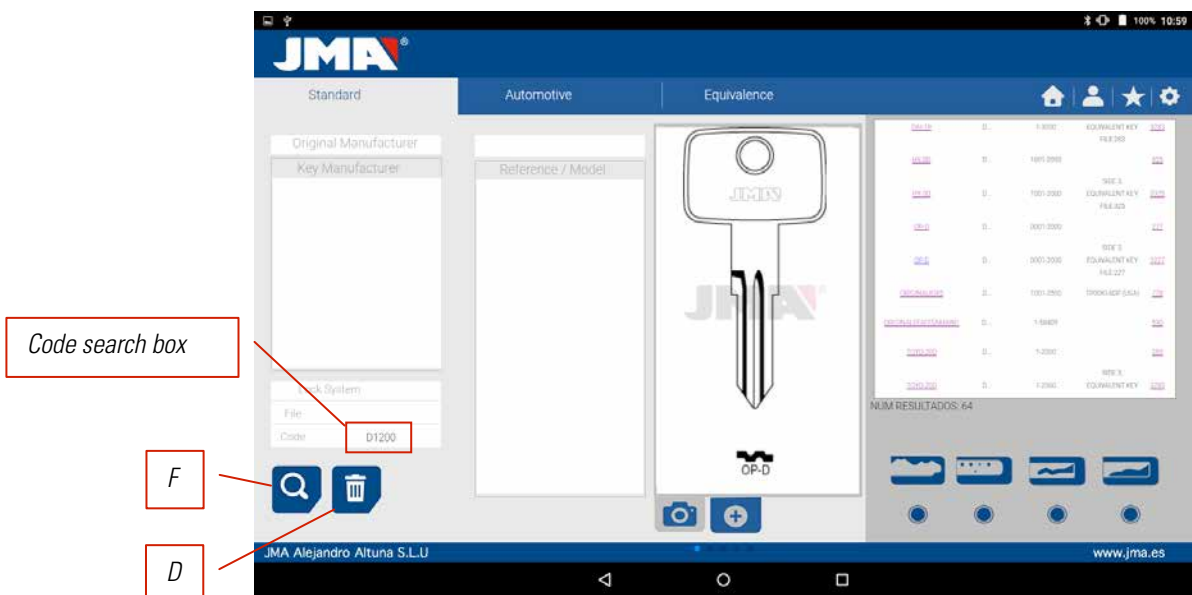

Indirect code: There is no relation with the biting.

e.g. key OP-D file 227 code D1200 -> biting 3344443123

The dots (.) in D series... 0001-2000 indicate the digits of the key series

Direct code: There is a direct relation with the biting.

e.g. key TE-81 file 476 code 12345A -> biting 12345

The dots (.) in A series... 1234567890 indicate the biting of the key

10.4.2 SEARCH BY AUTOMATION, BY TYPE, BY BRAND, MODEL AND YEAR (AUTOMATION AREA)

This search allows us to know the JMA key model used by an automation vehicle model (Car, Truck or Motorbike), in many cases the client can come with the original key of the vehicle and identifying the profile can be a difficult task, we can simply see which JMA key model is compatible with that model of automobile by the year of construction of that model.

The screenshot shows the JMA mobile application interface. On the left, there are filter options: Type (CAR), Branch (FORD), Model (FOCUS), and Year (2010). Below these filters are icons for search (F) and clear/erase (D). The main area displays a search result table with columns: REF, MODELO, MARCA, MODELO, AÑO, TP. The results table shows two entries for FORD FOCUS cars from 2005-2010. To the right, there is a large image of a key (I) with the JMA logo and a table (S) showing key details. The bottom of the screen displays 'JMA Alejandro Altuna S.L.U' and 'www.jma.es'.

To do that, all you need do is to define the search fields and press the search button (F) to perform the search and the clear/erase button (D) to make a new search. In this case, we have two boxes with results. The information box of the key (I) used by the selected vehicle, also giving information about the transponder system it uses.

In the following example, we can see how the FOCUS® car model of the brand FORD®, from the years 2005-2010 has a key similar to the JMA TPX2FO-24P, which includes the TPX2 transponder and blade profile FO-24P, which is cloneable on an original key, which includes a Texas® Crypto chip.

REF	MODELO	MARCA	MODELO	USO	TP
ORIGINALFO-24TL	FOCUS C-MAX	FORD	2003-2010	IGNITION	TEX/CR
TP20FO-24P	FOCUS	FORD	2005-2010	IGNITION	TEX/CR
TP20FO-24P	FOCUS C-MAX	FORD	2003-2010	IGNITION	TEX/CR
TPX2FO-24P	FOCUS	FORD	2005-2010	IGNITION	TEX/CR
TPX2FO-24P	FOCUS C-MAX	FORD	2003-2010	IGNITION	TEX/CR

On the other hand, the software notifies when we have all the necessary information to cut the key, in the series box (S). In this case, it notifies that with file 255P we can cut this key.

REF	PROFILE	SERIES	BILOCK	FILE
TE2FO-24P	---	0001-0000	---	255P
TE2FO-24P	---	10001-11500	FORD (USA)	255P
TE2FO-24P	---	0001-01500	FORD (USA)	255P

10.4.3 SEARCH FOR KEYS BY EQUIVALENTS WITH ANOTHER MANUFACTURER (EQUIVALENTS AREA)

This section of the program allows us to introduce references of keys that are not JMA references and will tell us the JMA equivalent and on the other hand it will give tell us if the key can be cut or not in the Multicode.

The selector include (P) allows us to search those words that include the wanted reference, if it is chosen, it will only show the keys that start with that reference.

In the search by key reference system we should press the search button (F) to make the search and later press the erase button (D) to make any other search with another word.

Filter of Manufacturers of blank keys

Manufacturers of keys that have that key reference

Key reference box

Result of key containing that reference.

Information about the lock manufacturer corresponding to that key reference.

P

F

D

10.5 CUTTING INFORMATION (FILE)

Once the program is connected to the Multicode in the JMAKeyPro program, we have access to see the technical information for cutting the key. If there is no link with the Multicode machine, this information is not accessible. We can differentiate the files into two families, according to the attaching area and the cutting tool to be used, therefore, we can denominate the following divisions:

- Toothed key files** Keys cut with the horizontal tool and where we have the MP1 jaw with four sides, the possibility of changing to other jaws, personalization of special key profiles.
- Point or channel key files** Keys cut with vertical tool, the jaw of this area has interchangeable clamps according to the model of key, the software will notify us of the clamp needed at all times. The machine will have to be adjusted each time the clamps are changed.

10.5.1 TOOTHED KEY FILES

When searching for a key (AZBE) or a biting code (e.g. 15000J) we can see its mechanical data by clicking on top of the file (in this case 507).

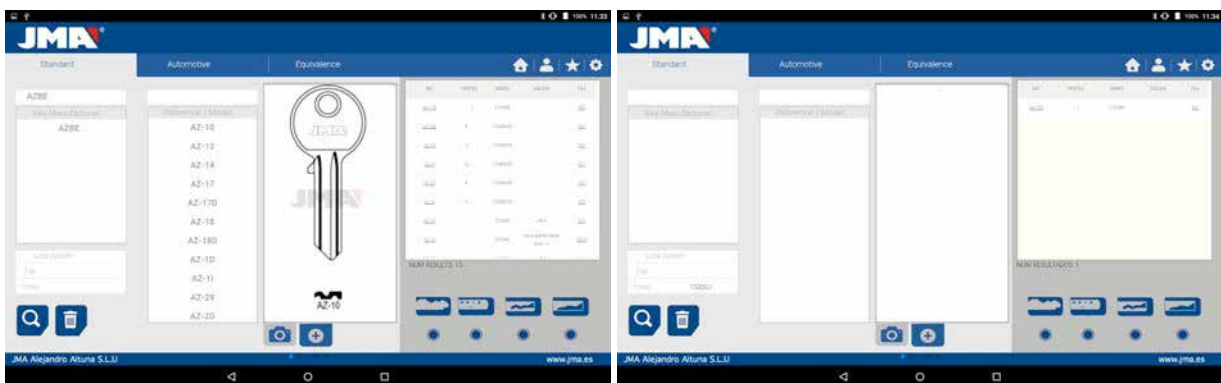

When clicking on the file we enter the file screen where we can see the technical data of the key and it will tell us how to attach the key, (side of the jaw, limit...).

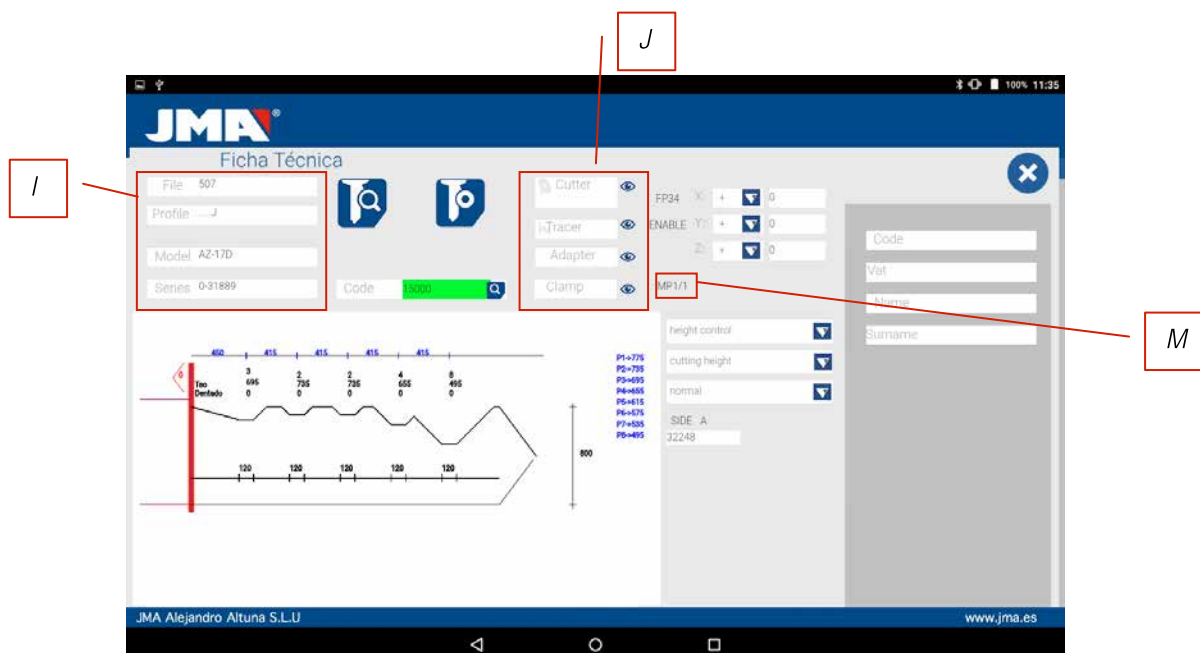

On one hand we have the information part (I) related to the key, the name of the file, the information of the cutting of the key in profile.

On the other hand, we have the code introduced, in this case 15000 and the biting related to this code 32248.

On another hand, we have essential information (J) about the cutter, feeler and jaw for this key, initially they are the standards already set in the machine. Clicking on the icon to view (👁️) we will have an image of each element.

Cutter FP34

Feeler-Reader toothed key

Jaw MP1

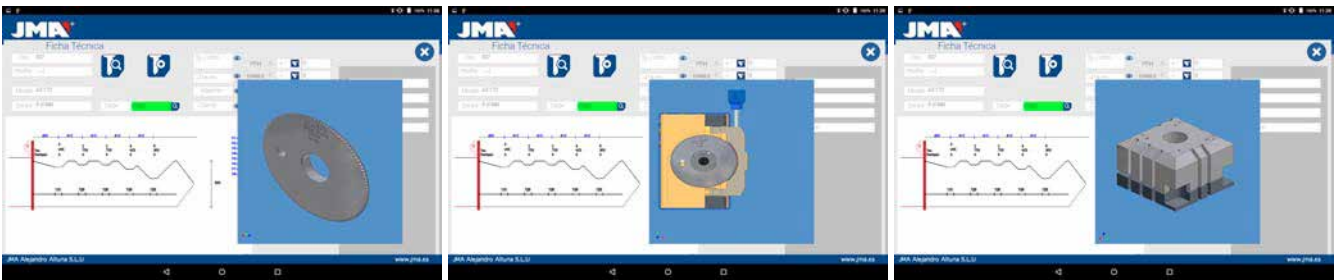

To remove the pre-visualization of each element, click on the image again.

Where and how to attach the key?

In jaw (see reference M in the drawing above) it gives us two details, on one hand the jaw in which the key is attached and on the other the side of the jaw. In this example MP1/1 indicates Jaw=MP1 and side of the jaw=1. If in this box it shows MP1/2, then Jaw=MP1 and side of the jaw=2.



The limit is referenced by the red line drawn on the representation of the cut of the key. That way, in this example it indicates Limit 0 and in the neck of the key. In the cases 1, 2 or 3 usually a limit is made at the point of the key, and using the point limit plate in the channels of face 1 of the jaw MP1.

See Chapter 3.1 referring to the tooth jaw, to see the limits and the indications of how to attach the key.

We can perform two actions in the file.

A) Reading of the key :

We can attach an original key as if we were going to machine it and later opening the tooth reader, pressing the read button to read the key by electronic contact.

After reading the key, the program tells us the biting code and shows us the heights it read in the cutting representation. Later when re-commanding the cutting of the key we can cut according to the official heights (theoretical) of the manufacturer or according to the heights read on the key.



B) Key machining

The key machining is just as easy as reading, it consists of attaching the key well and after introducing the biting cutting either directly (or by obtaining a code) or after the reading of an original key, we command the machining.

The biting of the key can be changed at any time by writing in the biting box

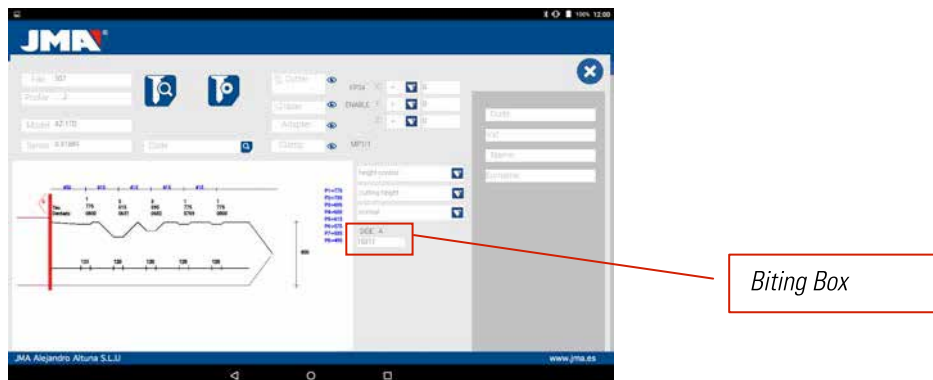

The information given to us by the file data screen is the same as in the case of reading but in the case of machining a biting key we can use different machining operations:

1) Height Control: Normal or Self-adjust cutting

The Multicode machine is already adjusted, and does not need to obtain a height reference each time that a toothed key is machined. As the reference of the key is given by its blade and this is already calibrated, usually a normal machining is used, but in the case of double biting keys (car keys), once one side is machined, there is no surface to calibrate the key for machining the second side of the key, therefore it is convenient to use side 3 or side 4 for attaching by channels, when using this side of the key the reference changes, therefore a new reference is needed, for this case we can use the self-adjusting cutting mode. The self-adjustment mode does the following before starting to machine, it takes the reference above the key, the file has the height data of the blank key, therefore the reference is taken this way, that way the key can be in another position and the machine adjusts by electronic contact. In the drawing below, we can see how that choosing between the two options, or nothing, the normal option is that selected by default.

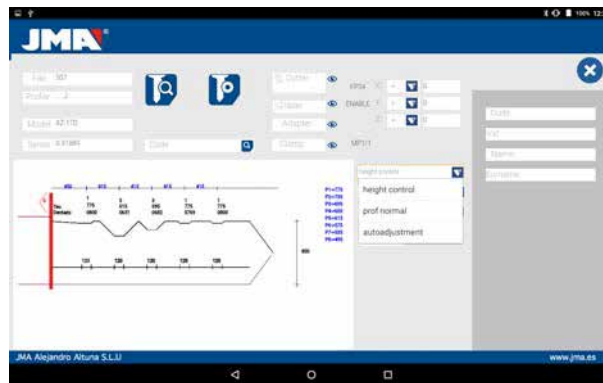

2) Height for machining: Theoretical or Read Height

As commented in the previous section, once a key has been read we have the values of the previously read keys. The program allows us to cut the key with the theoretical "original" values marked by the manufacturer or to the contrary cut the key with the read height values, with the error that this involves, but in old locks that are already vitiated, this could be the best option.



Machining a key with a read height can be combined with self-adjustment.

3) Cutting type: Normal, flat or ideal

Lastly we can change the cutting type we want to perform on the key, initially the file has a cutting type pre-established by the manufacturer, but the cutting type can be combined. The cutting types are as follows:

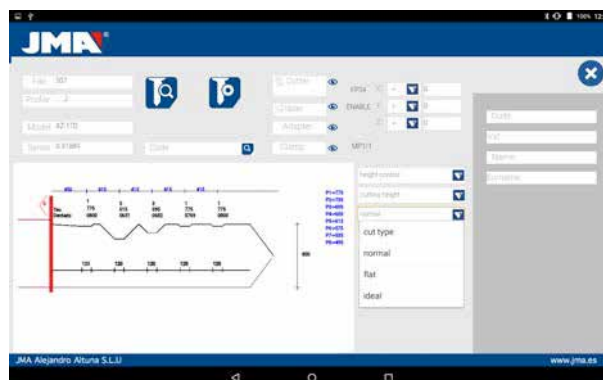

The cutting types are as follows:

NORMAL: For the traditional automobile keys and door locks.

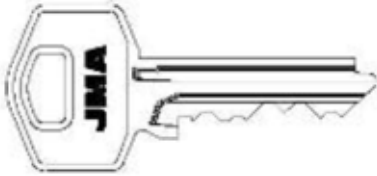

IDEAL: This is the most innovative that can be found in automobile locks, with this type of cutting the union between the angles of the biting is automatically defined by the machine, establishing codlings with variable angles. This facilitates the displacement of the key and extends the life cycle of the lock.

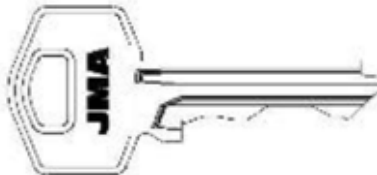

FLAT: This is used above all in automobile locks, in which the edges of the biting are eliminated to facilitate the displacement of the pistons or plates when introducing the key into the lock.



10.5.2 POINT KEY FILE

Following the compatibility with the Avantcode machine and the Xcode, the Multicode machine has the same names of files. That is why the files of the point and channel keys in "P", 1P, 2P ...

Access to the file is the same way as in the toothed key, by searching for a key (STS) or a tooth code we can see the series related to that manufacturer or code and by clicking on the file (in this case 305P) we can have access to the mechanical information.



In red File protected by password Authorization from the manufacturer is needed

File 305P

Once we have entered into the file we can see the data of the key In this case we have a key with 3 axes on face A/C and another axis on the lateral Face B/D.

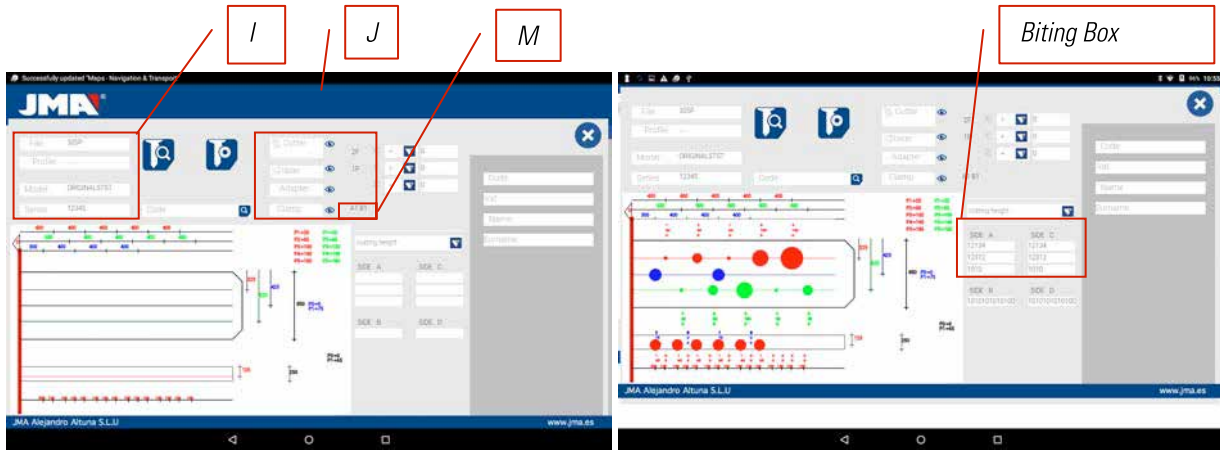

On one hand we have the information part (I) related to the key, the name of the file, series, the blank key that in this case is ORIGINAL.

On the other hand, we have the biting code introduced

FACE A: Axis 1:1234

Axis 2: 12312

Axis 3: 1010

FACE B:

Axis 1: 1010101010

On another hand, we have essential information (J) about the cutter, feeler and jaw for this key, initially they are the standards already set in the machine. Clicking on the icon to view (👁️) we will have an image of each element.

Cutter 2F

Feeler-1P

Jaw A1 B1

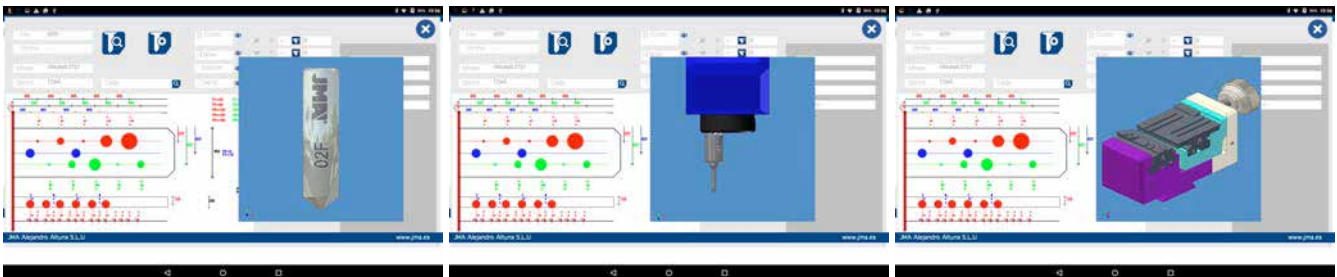

To remove the pre-visualization of each element, click on the image again.

Where and how to attach the key?

In jaw (see reference M in the drawing above) gives us another two details, on one hand the jaw which is where the key is attached and on the other side of the jaw (take into account that the clamps are reversible, A1 is one side of the clamp and A2 is the opposite side, any change of face will require an adjustment of the jaw and the 1P reader so that machine is well adjusted).



The limit is referenced by the red line drawn on the representation of the cut of the key. That way, in this example it indicates Limit 0 and in the neck of the key. In the cases limit 1 or 2 the point of the key, and using the point limit plate in the channels of face 1 of the jaw MP1.

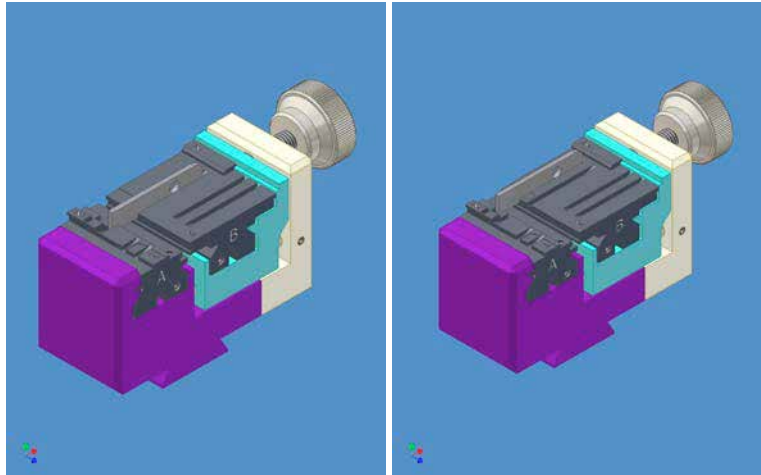

See Chapter 3.2 referring to the tooth jaw, to see the limits and the indications of how to attach the key.

We can perform two actions in the file.

A) Key reading

Like in the case of the toothed keys in the reading of keys shows us the biting code of the key and on the other hand the read height of the key.

The point and channel keys are read with the 1P feeler that already includes the vertical head. See Chapter 3.3.2.2

B) Key machining

The key machining is just as easy as reading, it consists of attaching the key well and after introducing the biting cutting either directly (or by obtaining a code) or after the reading of an original key, we command the machining.

The biting of the key can be changed at any time by writing in the biting box.

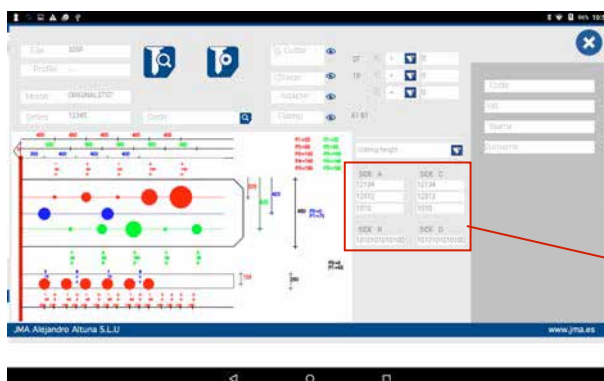

Biting Box

Attention should be given to the cutter installed in the machine, because although the cutters are standard and the machine performs the circular interpolation according to the width of the circle at the base of the spike, the lateral angle is given by the angle of the tool therefore it is necessary to use the adequate tool. The standard cutters supplied with the Multicode are as follows:

CUTTER 1F => Base = 2.5 mm Angle 0° (Straight cutter for channel keys for automation).

CUTTER 2F => Base = 0.4 mm Angle = 90°

CUTTER 3F => Base = 0.4 mm Angle = 100°

The information given to us by the file data screen is the same as in the case of reading but in the case of machining a point key there are only two different machining operations:

4) Height for machining: Theoretical or Read Height

As commented in the previous section, once a key has been read we have the values of the previously read keys. The program allows us to cut the key with the theoretical "original" values marked by the manufacturer or to the contrary cut the key with the read height values, with the error that this involves, but in old locks that are already vitiated, this could be the best option.

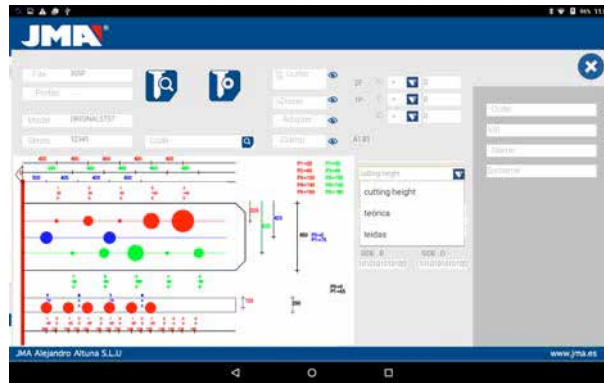

10.5.3 CHANNEL / SLOT KEY FILE

The channel / slot keys for automation are machined in the same area that the point keys are machined. In this case a special tool is used, it is the F1 which is a straight tool (for lateral cutting of the key), different to that of point keys (2F 90° and 3GF 100°)

The method for reading the key is similar to the point key because it uses the same feeler-tool 1P that comes incorporated into the vertical head. We are going to see a couple of examples to see the properties of file, in this case the examples are with the key TP00FI-16P (channel key, the biting are characterized in a channel in the blade) and the key TP00FO-24P (channel key, characterized for not having biting on the edge of the key).

In these two keys we can find the tooth code or have access to the key by writing the name of the key.

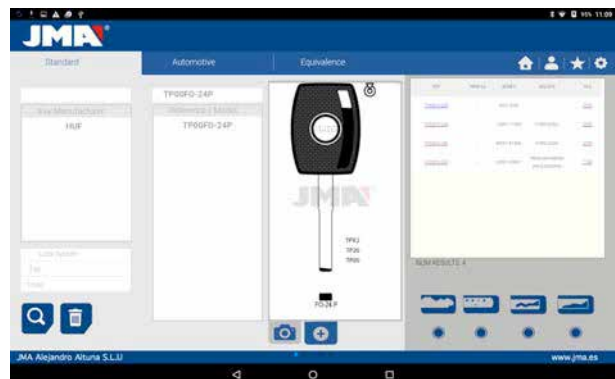
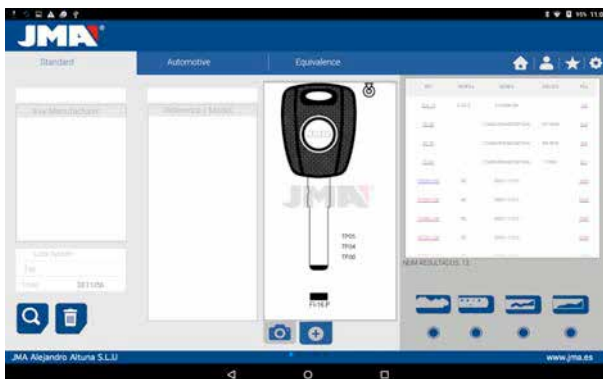

We are going to see the file of each key in the following drawing. In the case of the TP00FI-16P key (channel) we have searched for DE11056 and in the case of the key TP00FO-24P (channel) we have searched for code 2500.

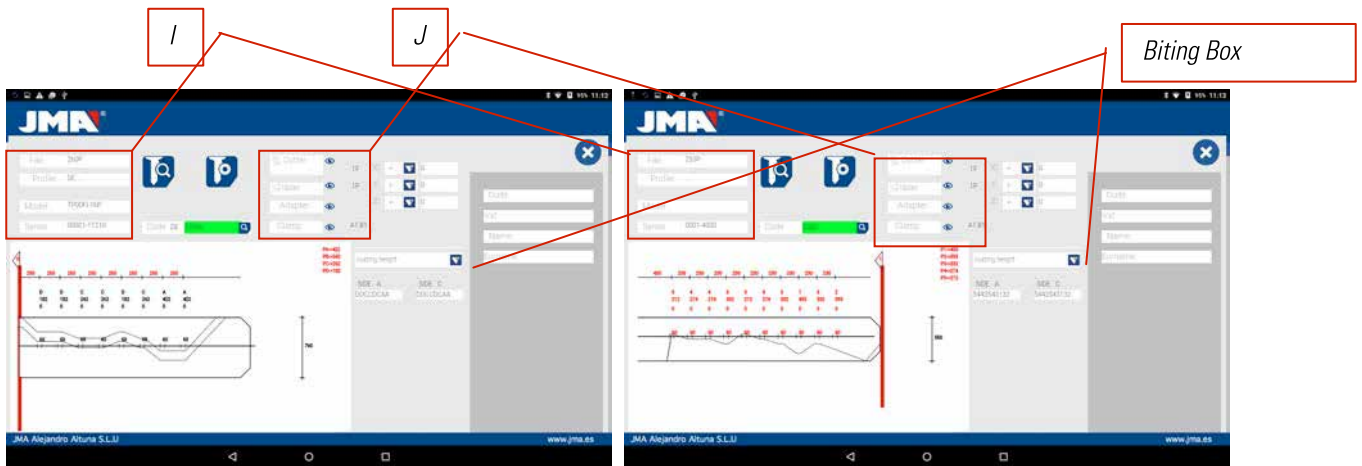

On one hand we have the information part (I) related to the key, the name of the file, series, the blank key that in this case is TP00FI-16P and TP00FO-24P.

On the other hand we have the tooth code obtained from the original code of the key:

TP00FI-16P -> Code: DE11056 -> Biting: DDCCDCAA

TP00FO-24P -> Code: 2500 -> Biting: 5443543132

On another hand, we have essential information (J) about the cutter, feeler and jaw for this key, initially they are the standards already set in the machine. Clicking on the icon to see (👁️) we have an image of each element and in the case of the TP00FO-24P key it shows us in which position of the jaw the point limit plate of the key is introduced.

Key TP00FO-24P

Cutter 1F

Feeler-1P

Jaw A1 B1 Limit 1

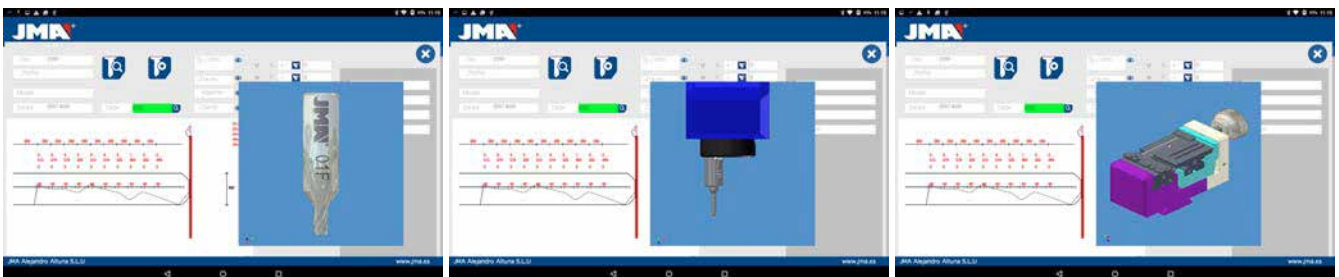

Key TP00FI-16P

Cutter 1F

Feeler-1P

Jaw A1 B1 Limit 1

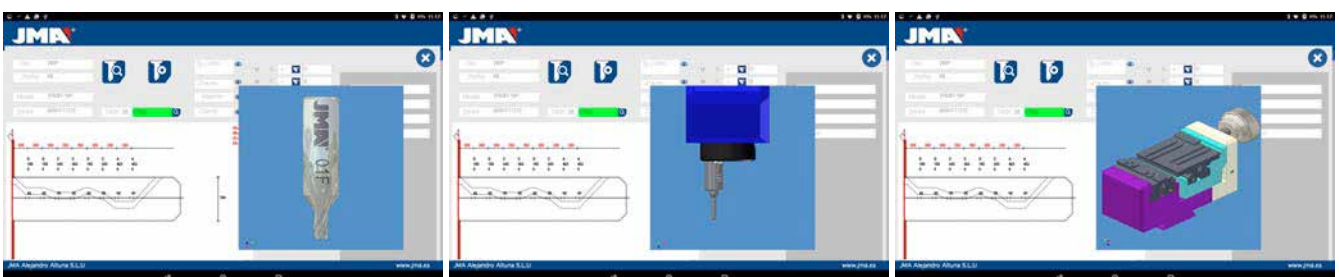

To remove the pre-visualization of each element, click on the image again.

Where and how to attach the key?

In jaw, we receive two details, on one hand the jaw which is where the key is attached and on the other side of the jaw (take into account that the clamps are reversible, A1 is one side of the clamp and A2 is the opposite side, any change of face will require an adjustment of the jaw and the 1P reader sp that machine is well adjusted).

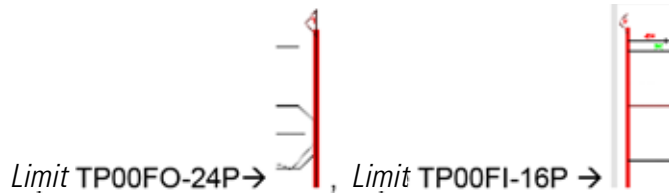

The limit is referenced by the red line drawn on the representation of the cut of the key. That way, this example shows us Limit 0 for the TP00FI-16P key (at the neck of the key) and Limit 1 in the case of the TP00FO-24P key (at the point of the key). In the case of Limit 1 using the point limit plate in the channels of face A1 of jaw A1

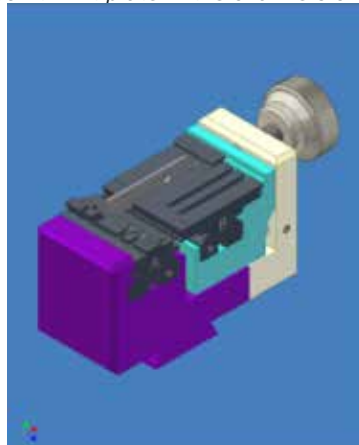

10.6 JAW SETTINGS

The Multicode machine is equipped with an electronic contact in the two tools, either the horizontal tool to cut toothed keys, either the vertical tool to cut point and channel keys are isolated and have an electronic sensor that detects collision or contact with the key or the jaw. This capacity of the machine allows us to adjust the machine using the CRG adjustment tools (toothed key part in the MP1 jaw) for the horizontal tool and the RP tool (points/channel key part in the A1 B1 jaw) placed in the tool holder of the vertical axis.

Access to the adjustment of the jaws is via the same area in both cases, go to settings (A) of the application and then choose the adjustment area (B).

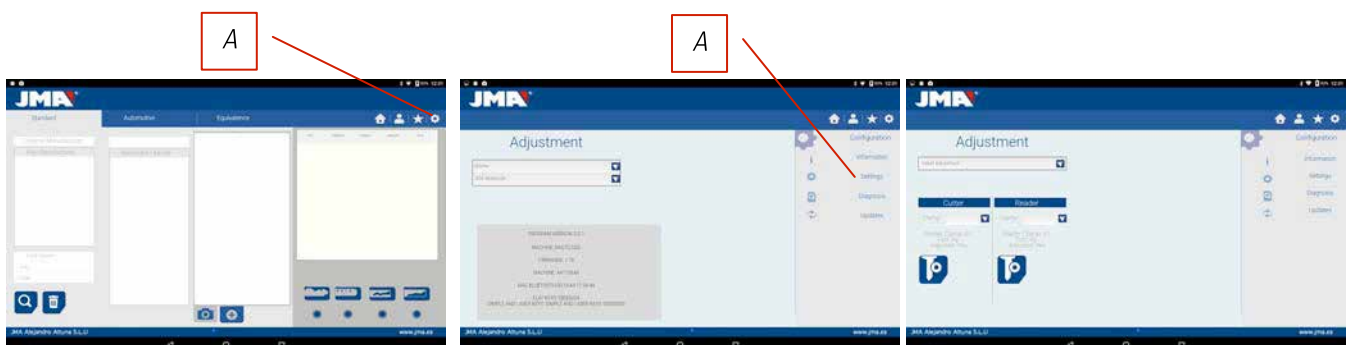

10.6.1 ADJUST FLAT KEY JAW

In the jaw adjustment menus we select the jaw (S) we want to adjust. In this case, we select flat keys adjustment (flat key).

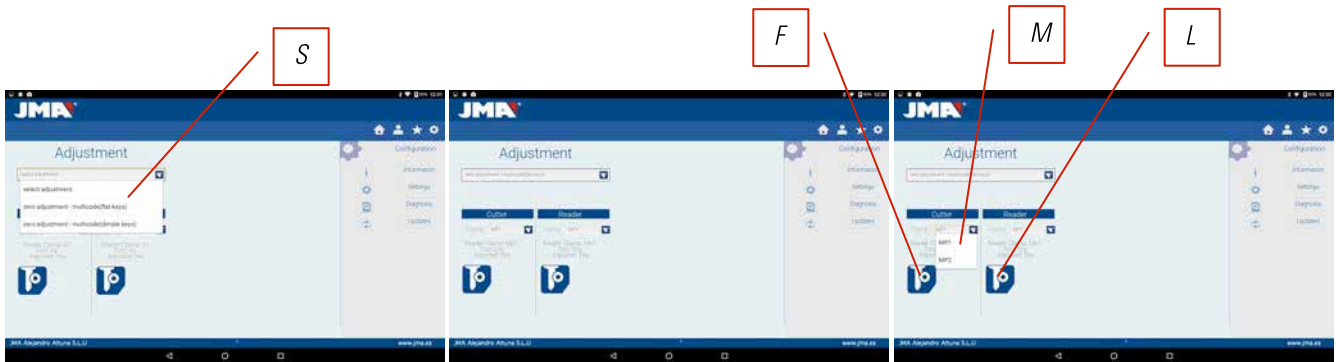

Adjustment of the toothed jaw is very simple, take the tool CRG and place it in face 1 of the jaw we are going to use (See Chapter 3.3.1 for placement of CRG in the jaw). In the menu we see, we can choose the jaw (M) we want, and after selecting the jaw, we press the button to adjust the part of the cutter (F); the adjustment process is automatic.

NOTE: The settings area is very important, the cutter fp34, crg has no swarf.

If we adjust the MP1 jaw... it is convenient also to adjust the reader of the toothed keys on the cutter. After finishing the adjustment of the cutter, remove the biting reader and without moving th CRG adjust the reader pressing the adjustment button (L)

10.6.2 POINTS/CHANNEL JAW ADJUSTMENT

In the jaw adjustment menus we select the jaw (S) we want to adjust. In this case, we select safety keys adjustment.

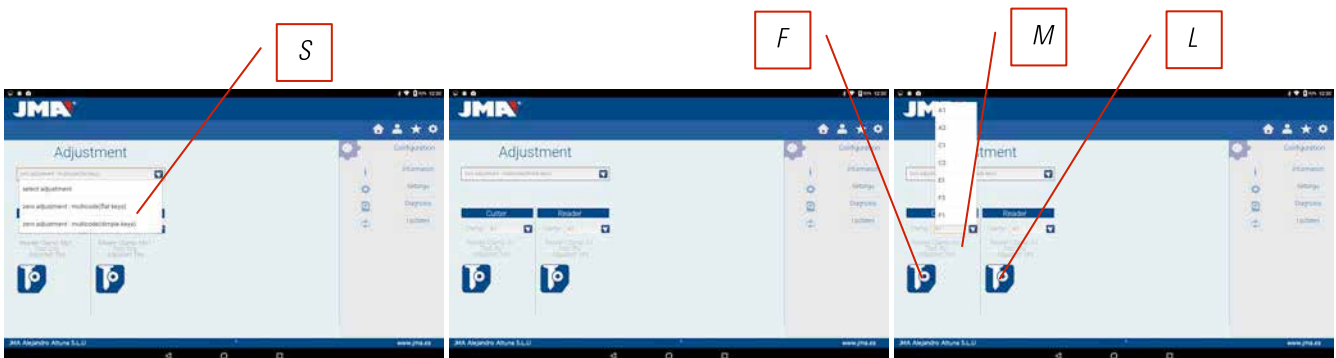

Adjusting the safety keys jaw is very simple, you have to take the RP tool and put it in the tool holder of the vertical axis (See Chapter 3.3.2.1 for the RP placement in the vertical head). In the menu we see, we can choose the jaw (M) we want, and after selecting the jaw, we press the button to adjust the part of the cutter (F); the adjustment process **is automatic**.

NOTE: The settings area is very important, the rp tool and the jaw have no swarf.

If we adjust the jaw A1... on the vertical head, it is also convenient that we adjust the safety keys reader 1P (See Chapter 3.3.2.2 for 1P placement). After finishing the adjustment of the vertical head in the cutter area with RP, lower the safety keys reader 1P and without moving the jaw A1... adjust the reader pressing the adjustment button (L).

10.7 UPDATE FIRMWARE

The Firmware updating process is automatic, because when the program starts and connects to the Multicode it checks the version of the same and if it is not adequate it jumps to the updating window.

Access to this same window can be obtained through "JMAKeyPro" Adjustments and clicking on the part of updating.

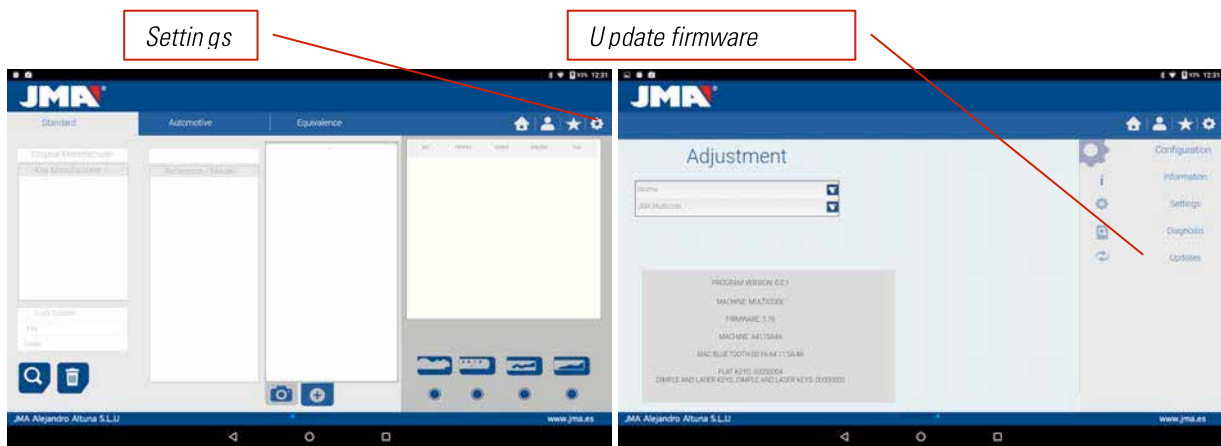

NOTE: It is only recommendable to make the update when it jumps to a later or higher version of the software. It is very important not to disconnect the machine until finishing the downloading process.

The updating process is very simple once we are in the following updating screen, we press ACCEPT and the process starts automatically. The green diode of the machine will start to flash and will show us the following message:

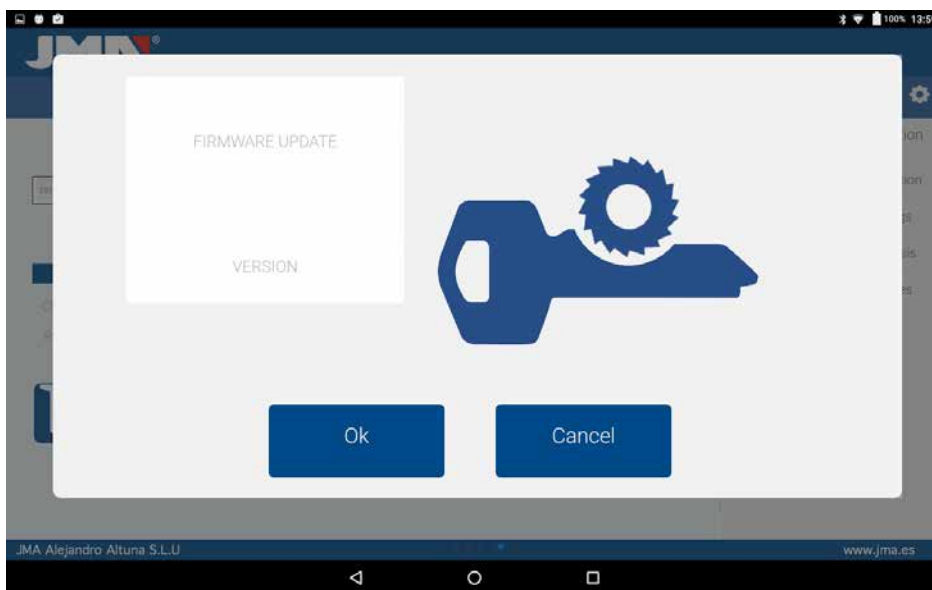

After having erased the Flash memory of the machine a process bar will appear with the following:

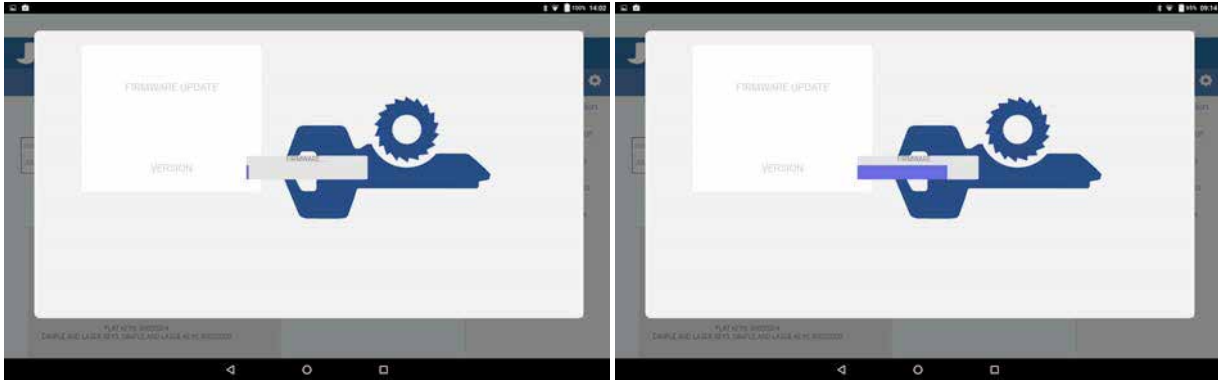

The updating process will take 30 minutes. Once the progress bar has reached its end, a message will appear for us to switch the machine off and on.

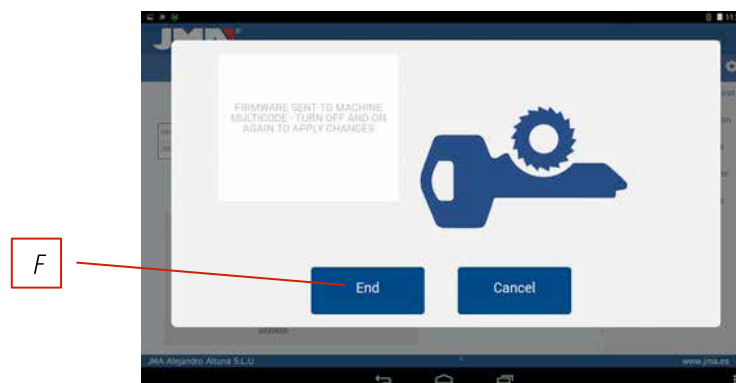

After the downloading process has finished, the above message appears, we can exit the "JMAKeyPro" application pressing the button END (F). We switch off the Multicode machine and then switch it on again, we will see the green diode flash, that is because the firmware program is updating. This is normal and the process will take from 5 to 10 minutes, until the diode becomes steady green, at that moment the Multicode is prepared to enter the application again and continue cutting keys.

10.8 DIAGNOSTICS

On the adjustment screen we can also find the machine diagnostics area, here we can test the good operation of motors.

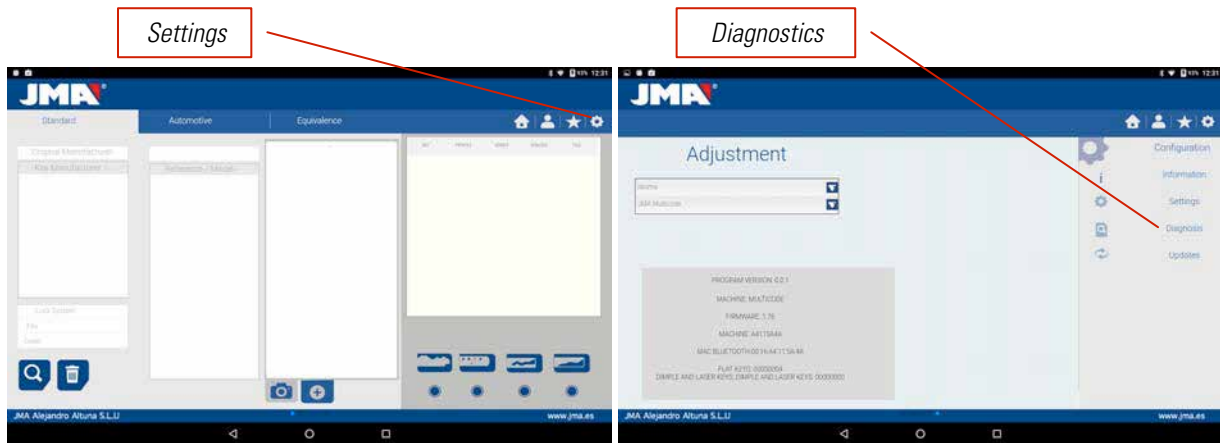

After choosing diagnostics in the adjustment area, we will see the following screen.

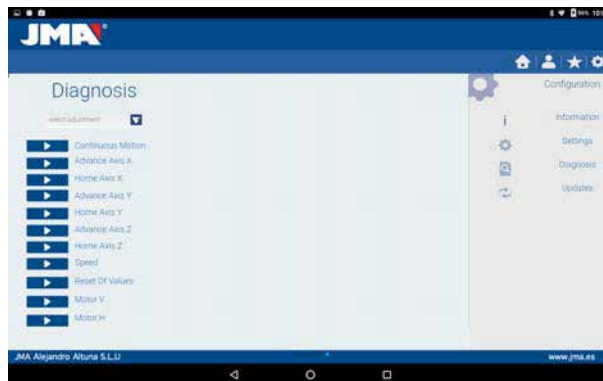

- 1.- Continuous movement. This function moves the three axes.
- 2.- Advance axle X, axle, axle X advances one step.
- 3.- Reverse Motor X in checking. Send motor X to start.
- 4.- Advance axle Y, axle, axle Y advances one step.
- 5.- Reverse Motor Y in checking. Send motor Y to start.
- 6.- Advance axle Z, axle, axle Z advances one step.
- 7.- Reverse axle Z. Send motor Z to start.
- 8.- Speed. Loads optimal speeds, in the case of resetting values.
- 9.- Reset to Factory settings. Resets to all factory settings. This option is protected with a password, and we recommend only doing it with the help of the JMA technical service.
- 10.- Motor V. Starts turning the vertical axle (point and channel keys).
- 11.- Motor H. Starts turning the horizontal axle (toothed keys).