

# Seal head unit 2.0

The innovative shock absorber sealing system

## Available applications:

Motorcycle, Snowmobile, side by side, ATV/Quad (All-Terrain Vehicle)

## The Seal head unit 2.0 provides reliable sealing for high-performance suspension components:

- Fully integrated one-part solution
- Specially developed new NBR compound suitable for temperatures of -40 °C to +140 °C
- Plastic back-up ring reduces friction and wear under high operating pressure
- New static outer diameter seal design allows easier assembly and removal
- All-new rebound bumper and mating plate provide smoother kick back and longer service life

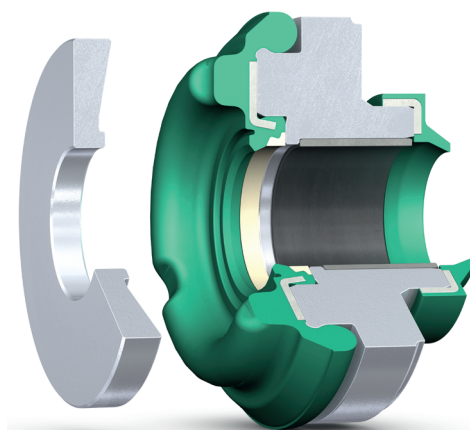

*Share the proven success of SKF two-wheeler sealing solutions for the ultimate riding experience.*

## SKF benefits

- Simplified installation compared to previous design
- Robust sealing over a wide temperature range
- Improved service life and performance
- Reduced friction and wear
- Compact solution to maximize stroke/ minimize shock absorber length
- One-part solution facilitates logistic efforts

## The special design features of the new Seal head unit 2.0 are:

- New static outer diameter seal as part of the unit.
- Optimized metal stamping to support all the features
- Optimized back-up ring to support the main lip
- New NBR rubber compound
- New rebound bumper
- New rebound mating plate with proprietary design included in all kits

[serco.com.au/skf](http://serco.com.au/skf)

© SKF is a registered trademark of the SKF Group.

© SKF Group 2016  
The contents of this publication are the copyright of the publisher and may not be reproduced (even extracts) unless prior written permission is granted. Every care has been taken to ensure the accuracy of the information contained in this publication but no liability can be accepted for any loss or damage whether direct, indirect or consequential arising out of the use of the information contained herein.

PUB SE/P8 16959 EN · October 2016

For further information,  
please contact:

[sales@serco.com.au](mailto:sales@serco.com.au)