

CETOP8

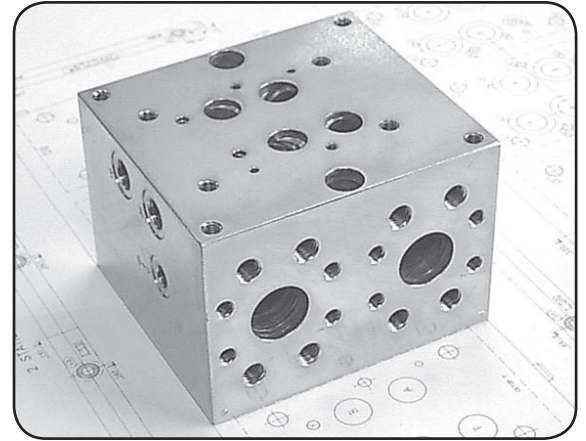
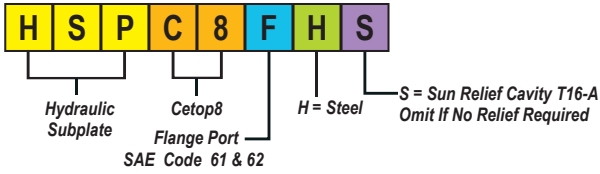

Specifications	
Material :	Steel - AS3678:250
Max. Working Pressure :	Steel - 350 Bar
Surface Treatment :	Steel - Zinc Gold Passivation
Port Sizes :	P & T - 1-1/2" SAE 61 & 62      A & B - 1-1/2" SAE 61 & 62 X , Y & L - 3/8" BSPP                      G - 1/4" BSPP

Included Components	
Socket Head Cap Screws :	(Inc. 4 x M12 Nuts) 4 each M12 x 120
Flat Washers :	4 each M12

## Technical Details

**MTG THREAD INFORMATION**  
SAE CODE 61 - 1/2" UNC x 26 DP  
SAE CODE 62 - 5/8" UNC x 24 DP

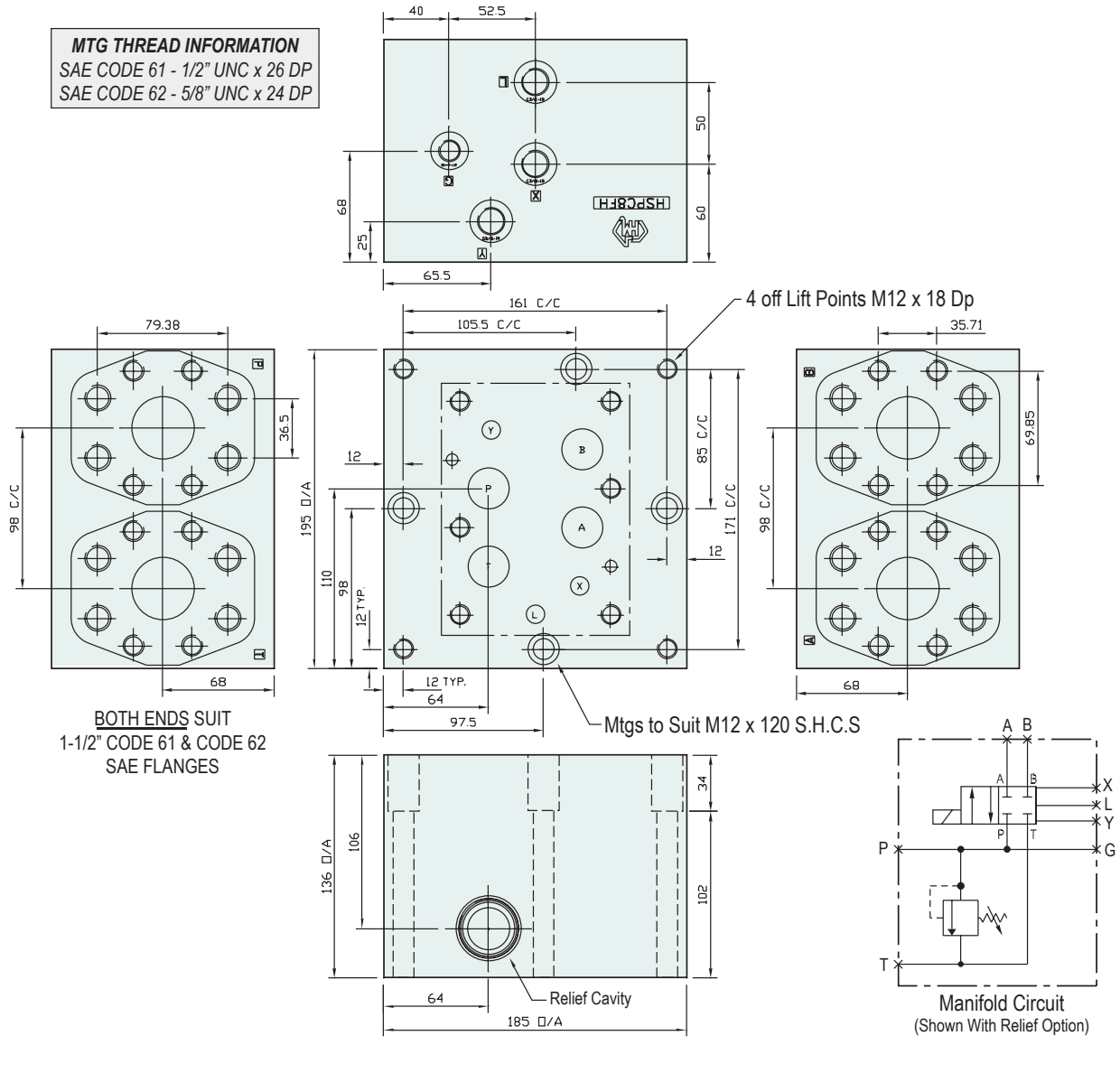

## Subplate - No Relief Cavity      Subplate - With Relief Cavity

Part Number	Nominal Mass Kg
HSPC8FH	34.0

RELIEF VALVES SOLD SEPARATELY  
SUN RELIEF VALVE    RPIC-LCN

Part Number	Nominal Mass Kg
HSPC8FHS	34.0