

H B P C 3 *

Hydraulic
Blanking Plate

Cetop3

M = Alloy
H = Steel

Specifications

Material :	Alloy - 6061-T6	Steel - S1214
Max. Working Pressure :	Alloy - 210 Bar	Steel - 350 Bar
Surface Treatment :	Alloy - Nil	Steel - Zinc Gold Passivation

Included Components

Socket Head Cap Screws :	4 each M5 x 30
O-Rings :	4 each N9-012

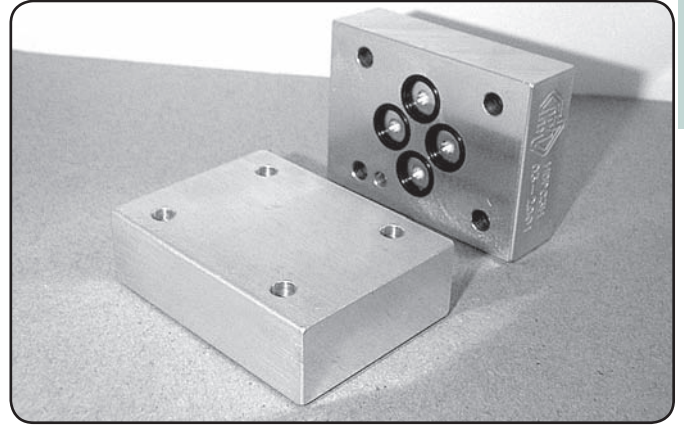

CETOP
3

Technical Details

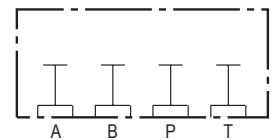
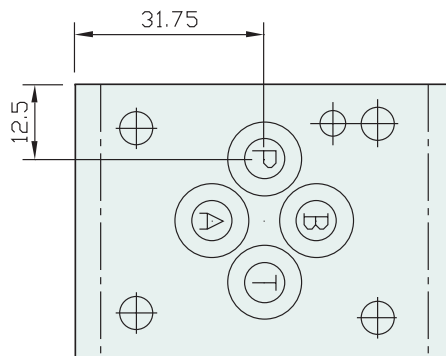
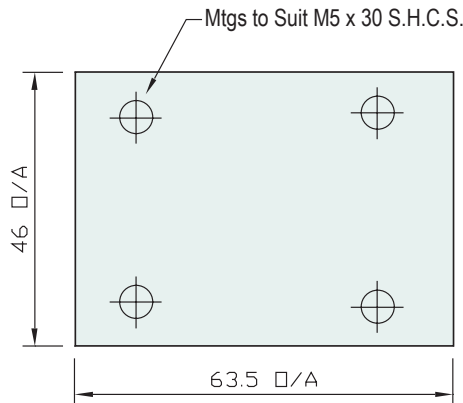

Manifold Circuit

Projection



Part Number	Nominal Mass Kg
HBPC3H	0.5
HBPC3M	0.2