

# OWNER'S MANUAL

# POOL LAB<sup>®</sup>

## PL Series Automatic Chlorinator

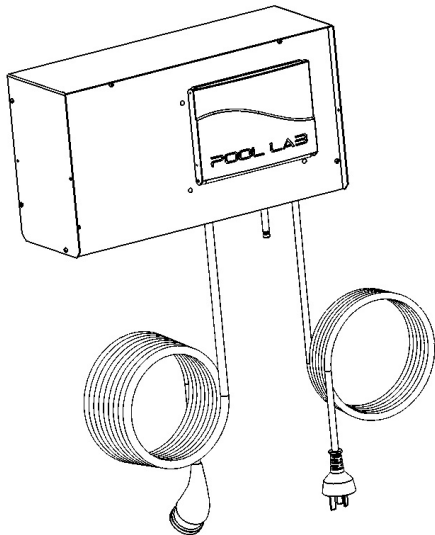

Patented Technology

Patent Technology Numbers:

Australia No. 2004245133

Canada No. 2528374

Europe No. 04736187.8

New Zealand No. 544430

USA No. 7,658,842

### IMPORTANT

Read this manual carefully before operating your  
Pool Lab Automatic Chlorinator

## Ideal Salinity 3000ppm

**KEEP THIS MANUAL IN A SAFE PLACE  
FOR FUTURE REFERENCE**

Manufactured by Poolpower Australia Pty Ltd  
Factory 1b, 39-45 Susan Street  
ELTHAM, VICTORIA, AUSTRALIA 3095

email: [service@poolpower.com.au](mailto:service@poolpower.com.au)

rev. 5

# IMPORTANT SAFETY INSTRUCTIONS

When installing and using this electrical equipment, basic safety precautions must always be followed.

## READ AND FOLLOW ALL INSTRUCTIONS

- **WARNING:** Disconnect all AC power during installation and or removal of the equipment.
- **WARNING:** Potential risk of fire, electric shock, or injury to persons if the installation and safety instructions listed in this manual, and on the equipment itself are not followed.
- **WARNING:** To reduce the risk of injury, do not permit children to use this equipment unless they are closely supervised at all times.
- **WARNING:** Always wear safety goggles and suitable gloves when handling pool chemicals, and follow usage directions carefully.
- **WARNING:** Use of a suitable respirator is recommended when handling Hydrochloric Acid (aka. Muriatic Acid).
- **DANGER:** DO NOT ADD WATER TO ACID. Always add acid to water
- **SAVE THESE INSTRUCTIONS FOR FUTURE REFERENCE**
- Heavy pool (or Spa) usage, and/or higher temperatures may require higher chlorine output to maintain proper free chlorine residuals.
- If additional chlorine is required due to heavy bather loads, use liquid chlorine (Sodium Hypochlorite) to maintain appropriate free chlorine residual.
- High salt or chlorine levels above recommended range may contribute to corrosion of pool or spa equipment.
- DO NOT add pool or spa chemicals directly to the skimmer.
- Check expiry dates of test kit consumables.
- Use only original Pool Lab replacement cells with identical model numbers.
- Follow all aspects of local and national Electrical Codes when installing Pool Lab equipment.
- For outdoor pools, chlorine residuals can be protected from destruction from the sun by appropriate addition of stabilizer (cyanuric acid)

## ***Health and Hypothermia Warnings***

- People with a medical condition should consult a physician before entering the pool or spa water.
- Maximum safe spa water temperature is 40°C.
- Bathing in water at 40°C should not exceed 15 minutes.

# Table of Contents

IMPORTANT SAFETY INSTRUCTIONS.....	2
Health and Hypothermia Warnings.....	2
GENERAL PRECAUTIONS.....	4
ELECTROLYTIC CELL PRECAUTIONS.....	4
INTRODUCTION.....	5
CELL MAINTENANCE.....	6
TO REMOVE & INSPECT THE ELECTRODE.....	6
CLEANING THE ELECTRODE – CALCIUM SCALE.....	7
INSTALLING THE ELECTRODE.....	7
CONTROL PANEL OVERVIEW.....	8
SETTING THE TIME AND DATE.....	9
SETTING ON / OFF TIMERS.....	9
SPECIAL FEATURES.....	10
USER AUTHORITY LEVEL.....	10
PUMP PROTECTION MONITOR.....	10
PLUMBING FLUSH.....	10
HYDROGEN GAS SAFETY.....	11
DIAGNOSTIC MESSAGES.....	12
CHECK SALT.....	12
CHECK SALT CELL OFF.....	12
HIGH SALT.....	12
HIGH SALT CELL OFF.....	12
PUMP PROTECTION ACTIVE.....	13
LOW FLOW.....	13
SPA FLOW DETECTED.....	13
DEFAULTS USED.....	13
MEMORY FAULT.....	13
CHLORINE PRODUCTON AND CONTROL.....	14
FREE CHLORINE LEVEL.....	14
ALTERING CHLORINE OUTPUT.....	14
WATER BALANCE.....	15
pH.....	15
TOTAL ALKALINITY.....	15
CALCIUM HARDNESS.....	15
SALT LEVEL.....	15
CHLORINE STABILIZER – CYANURIC ACID.....	16
Combined Chlorine - Chloramines.....	16
High Calcium (Hard) water sources – the Langlier Saturation Index.....	17
WATER CIRCULATION.....	18
INSTALLATION.....	19
PLUMBING.....	19
Cell Installation.....	19
Positioning the Cell.....	19
Plumbing Example.....	20
POWER SUPPLY AND CONTROLLER.....	21
SALT.....	22
INITIAL SALT DOSING – IDEAL SALINITY 3000ppm.....	22
SALT ADDITION TABLE.....	22
TROUBLESHOOTING.....	23
WARRANTY INFORMATION.....	26
DOMESTIC APPLICATIONS.....	26
COMMERCIAL APPLICATIONS.....	26

## GENERAL PRECAUTIONS

- Do not use bromine based products in the pool. Use of bromine will void the warranty on your chlorine cell.
- It is the pool owner's responsibility to ensure water is regularly tested and balanced. Your local pool professional can advise you on appropriate testing frequency and balance criteria in your area.
- Where calcium hardness of the pool / spa water exceeds 200ppm, the water must be balanced as per the Langlier Index to ensure water is not scale forming. Consult you local pool professional for advise.
- Do not assume the chlorinator is faulty if a chlorine test reveals a low free chlorine level. There are many factors that relate to chlorine demand in the water. Refer to the troubleshooting guide in this manual for more information
- Regular manual 'super chlorination' or 'shock dosing' may be required in pools where chlorine demand or bather load is high.
- Manual addition of liquid chlorine may be required to supplement chlorine requirement during peak usage periods.
- Test salt level before calculating your salt addition requirements, even on a new installation – especially where liquid chlorine had been used previously.
- Free chlorine levels above 4.0ppm may void manufacturer warranties on your equipment.
- Unnecessarily high salt levels may contribute to corrosion of pool and spa equipment.
- **Pool Lab recommend the use of Cyanuric Acid (Stabilizer) at a concentration of between 50-80 ppm for outdoor pools to help protect chlorine in the water from destruction by sun light**

## ELECTROLYTIC CELL PRECAUTIONS

- **It is a condition of the warranty that the pool owner ensure that the cell is inspected and maintained in accordance with the directions in this manual.**
- The chlorine cell is generally self cleaning, but certain water conditions can inhibit the effectiveness of this function. Therefore the cell should be visually inspected on a regular basis to ensure it is not fouled with debris or accumulating calcium. Refer to instructions on cleaning the cell in this manual if required.
- If calcium scale is allowed to build up on the electrode plates to the point where the calcium bridges the gap between the plates, this can permanently damage the electrode and will void the electrode warranty.
- If you have water conditions that cause calcium to build up in the chlorine cell, then the cell **MUST** be cleaned on a regular basis as per the instructions in this manual. *As a general rule, if the cell requires more than 15 minutes to clean, then it must be cleaned more regularly.*
- **It is the pool owner's responsibility to ensure all materials in contact with the pool or spa water are compatible with and intended for use with an electrolytic salt chlorinator.**

# INTRODUCTION

Congratulations, you have wisely purchased the most technologically advanced salt water chlorinator in the world. The benefits of doing so will be evident for many years to come. Pool Lab's research and development team is committed to producing the finest chlorination systems and being recognized world wide as the leaders in salt chlorination technology.

Your Pool Lab chlorinator will eliminate the need to store dangerous quantities of chlorine, daily manual chlorine dosing and the risks associated with these practices. It is automatic, clean, safe and economical and for these reasons, salt chlorination as a method for treating pool water is increasing world-wide.

Mild salt water is gentle on eyes and skin and is said to benefit asthma sufferers and those people who find conventional chlorinated pools irritating. The salinity of seawater is approx. 35,000ppm or 3.5%, while Pool Lab chlorinators require only 3,000ppm or 0.3%. The human body has a salinity of approx. 4500ppm and fresh water is zero. It is the similarity between the salinity of the human body and that of a salt pool that make for a silky luxurious swimming experience.

The chlorinator comprises two basic components, the power supply and cell. It is within the cell that the electrolytic reactions occur. Chloride ions in the water are converted into chlorine gas, this dissolves immediately into the water to ultimately form sodium hypochlorite (liquid chlorine). The chlorine oxidizes bacteria, algae and other harmful matter in the pool water and through this process reverts back into available chloride ions.

The major by-product of the reaction in the cell is the liberation of Hydrogen gas at the cathode. This explains the small bubbles often seen passing out of the pool returns. Pool Lab's patented vertical cell is the worlds safest and ensures the excess hydrogen gas can not accumulate to dangerous levels.

No salt is lost through the electrolytic process. The necessity to top up the salt level is only due to loss of salt water from backwashing or splashing out etc. Water loss due to evaporation does not cause any loss of salt. All Pool Lab models contain digital time clocks with two programmable ON/OFF periods available for fully automatic operation of your pump & chlorinator.

**All models have a built in back up power system that will keep the timer clock running for up to 7 days. This is particularly useful where the mains power is interrupted.**

**Pool Lab PL Series does not contain batteries.**

# CELL MAINTENANCE

Where calcium levels are below 200ppm, the mineral content is low and the water is correctly balanced, little or no maintenance to the cell is normally required. The automatic reversing of the electrode polarity will be sufficient to dissolve the calcium scale formed.

Periodic inspections must however be made to ensure scale and or debris is not forming or building up on the electrodes within the cell. If a calcium scale has formed it must be removed by cleaning in an acid solution.

Where calcium levels are higher than 200ppm and or mineral content is high, regular inspections of the cell must be performed. If calcium scale is present, the cell must be cleaned in an acid solution. The higher the water temperature, the greater the capacity for the water to deposit scale on the cell. Each pool will vary with regard to the frequency of cell maintenance. Factors which increase the cell cleaning frequency are:

- Calcium Hardness above 200ppm
- High Water Temperatures
- Low water velocity
- Poor Water Balance
- Excessive salt level
- Electrode breakdown – ensure a qualified technician evaluates the cell

## **TO REMOVE & INSPECT THE ELECTRODE**

- Switch off power to the chlorinator and pump(s).
- Close all relevant valves – especially where the cell is located lower than the pool water level, or where the pump(s) are significantly above the water level.
- Unplug the cell cable from the cell, and place cable end in a dry location.
- Loosen the large cell nut, and remove it from the cell.
- Carefully remove the electrode from the cell housing. Where the cell is located above the pool water level, and the cell is not completely isolated by valves, beware that there may be a vacuum in the cell housing. This can sometimes make the electrode difficult to remove. Take care not to lose the o-ring.  
*Depending on your system setup, the vacuum can sometimes be relieved by briefly pushing down on the multi-port valve handle on a sand filter, or by opening a relief or drain valve momentarily.*
- Visually inspect for debris accumulated at the bottom of, or between the electrode plates. Most debris can usually be cleared by simply dunking the electrode up and down rapidly in water. Excessive debris could indicate a filtration problem.
  - \* **DO NOT USE A METAL TOOL TO REMOVE DEBRIS AS THIS WILL DAMAGE THE ELECTRODE COATING!!**
  - \* **DO NOT ATTEMPT TO MANUALLY REMOVE ANY CALCIUM SCALE**
- Visually inspect between the electrode plates for calcium build up. This appears as a hard white material that coats the surface of the plates and can also bridge the gap between the plates. Electrode plates should be smooth and matte black.

## **CLEANING THE ELECTRODE – CALCIUM SCALE**

You will need hydrochloric acid (33%), and a plastic container or bucket deep enough to stand the electrode vertically in with the electrode plates fully submerged. The container or bucket should be preferably not too broad, as this will require a larger amount of acid. A standard 10 Litre bucket is usually acceptable.

You will also need safety goggles and protective gloves.

- Remove any loose debris from the electrode by dunking it up and down rapidly in water.
- In your container or bucket mix approximately 1 part hydrochloric acid to 5 parts water. Make the solution slightly too shallow at first, then top up later with water to just cover the electrode plates.

*Note: Less acid can be used (down to 1:10 ratio) if the calcium build up is not too excessive, but the cleaning process will take longer.*

**ALWAYS PUT WATER IN THE CONTAINER FIRST, THEN ADD ACID.**

- Carefully place and stand the electrode in the container, **taking care NOT to submerge the top part** where the electrical connector is. Top up the container with fresh water if required until the electrode plates are just covered by the solution.  
*Note: ACID REACTING WITH THE CALCIUM SHOULD PRODUCE BUBBLES*
- Leave the electrode in the solution until the bubbles stop. The reaction will usually be fast initially, then slow down.
- Once you are satisfied the reaction has stopped, carefully remove the electrode from the solution, and rinse with fresh water.  
*Note: If calcium scale was excessive you may need to repeat this process with a fresh acid solution.*
- Visually inspect the cell to ensure you are satisfied it is clean. If some scale-like build up remains and it appears that acid is not removing it, then it may not be calcium scale. You can try rinsing the cell with hot tap water (not boiling water) which can sometimes help.

## **INSTALLING THE ELECTRODE**

- Visually inspect the condition of the o-ring, and replace if necessary.
- Apply a small amount of silicone grease to the o-ring if required.
- Fit the o-ring to the cell head, ensuring it is on the bottom side of the cell head flange (same side as the electrode plate bundle).
- Fit the electrode into the cell housing, and orient it so that the cell cable can plug into the cell easily and comfortably.
- Fit the cell nut, and tighten by hand only.
- Connect the cell cable to the cell.
- Open any valves that were closed prior to the electrode being removed.
- Re-connect power to the chlorinator and pump(s).
- Run the system – and check for any leaks.

# CONTROL PANEL OVERVIEW

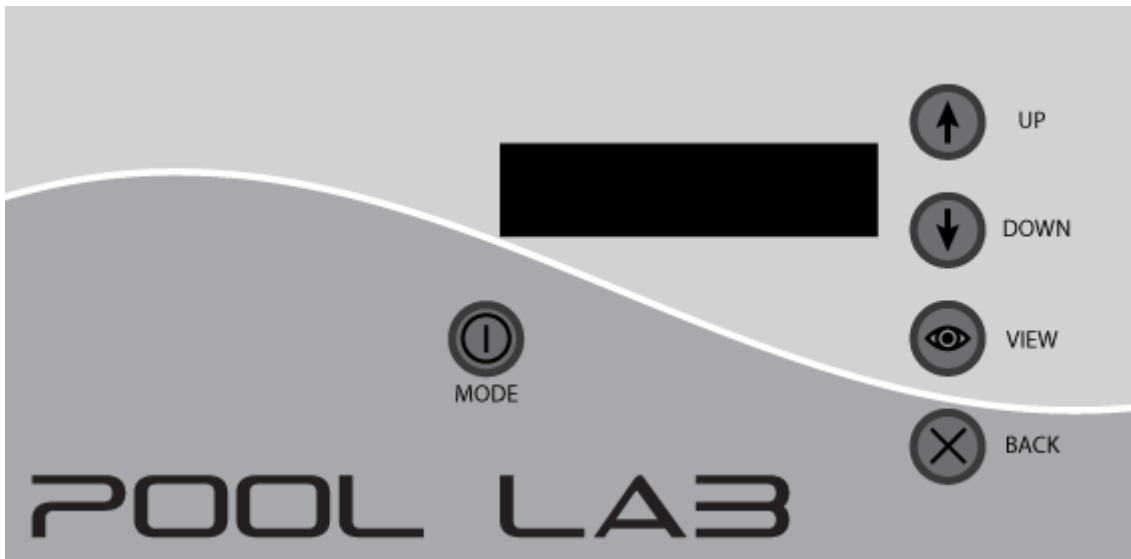

## LCD DISPLAY

- The display has three top level views, and a menu system:
  - HOME – Displays running mode and chlorinator output.
  - TIME/DATE – Displays current time and date
  - TIMER – Displays filtration ON / OFF times
  - MAIN MENU – Access settings and configuration items

## UP / DOWN BUTTONS

- Adjust the chlorine output level (view “HOME”)
- Adjust the time / date (view “TIME/DATE”)
- Adjust the ON / OFF times (view “TIMER”)
- Navigate menu system (menu system list views)
- Adjust values (menu system field editing)

## VIEW BUTTON

- Switch between LCD display top level views
- Moves to the next adjustable field, or set adjusted field
- Hold for 5 seconds to enter the MAIN MENU (view “HOME” only)
- Select a menu item, or edit a field (menu system views)

## BACK BUTTON

- Return to previous view, or return to view “HOME”
- Exit adjustment mode
- Display detailed cell output data (view “HOME”)

## MODE BUTTON

- Toggle ON / OFF / AUTO running mode.
- Returns to HOME VIEW (from any top level view)



## SETTING THE TIME AND DATE

Time is displayed in 24 hour format. 00:00 is midnight, 12:00 is midday.

Date is displayed in day / month / year format.

Setting the correct date will allow the system to automatically adjust for daylight savings time.

The clock will continue to run for several days without power. If power is disconnected for an extended period of time, the clock may reset.

- Press the VIEW button once from the HOME VIEW to display the TIME / DATE VIEW.
- Current time and date settings are displayed.
- Press either the UP or DOWN button once to enter adjustment mode.
- The HOUR digits will be flashing to indicate adjustment mode.
- Use the UP and DOWN buttons to select the correct HOUR value
- Press VIEW to switch to the MINUTES field.
- Use the UP and DOWN buttons to select the correct MINUTES value
- Continue this process for YEAR, MONTH, and DAY fields.
- Press VIEW to save the settings.

## SETTING ON / OFF TIMERS

Two separate ON / OFF time periods for the filtration pump are available. You can use either one, both or none of these depending on your requirements.

Time periods can be set to traverse midnight.

Time periods can overlap, in which case they will be treated as one time period.

Either or both of the timers can be disabled by setting both ON and OFF times the same.

A disabled timer will show ON and OFF times as dashes (--:--)

Timers are labeled #1, and #2.

The first column shows the ON time.

The second column shows the OFF time.

Time period settings should be retained even after extensive periods without power.

- Press the VIEW button twice from the HOME VIEW to display the TIMERS VIEW.
- Current ON / OFF times are displayed.
- Press either the UP or DOWN button once to enter adjustment mode.
- The HOUR digits of ON time #1 will be flashing to indicate adjustment mode.
- Use the VIEW button to cycle to the field you need to adjust.
- Use the UP and DOWN buttons to select the correct value.
- When finished, use the VIEW button to cycle past the last adjustable field to save the settings.

# **SPECIAL FEATURES**

## ***USER AUTHORITY LEVEL***

To prevent accidental changes to critical settings, the Pool Lab PL Series incorporates a user authority level. By default the authority level is set to USER. Before any critical settings can be edited, the user authority level must be raised to INSTALLER. There is also a LIMITED level which prevents adjustment of all settings, and there are also TECHNICIAN and FACTORY levels which require a PIN.

To enable editing of system settings, you must first raise the AUTHORITY level to INSTALLER.

- From the HOME VIEW, press and hold the VIEW button for at least 5 seconds.
- This will show the MAIN MENU.
- Navigate to SYSTEM CONFIG, and press VIEW
- Navigate to AUTHORITY, and press VIEW
- Press VIEW again to edit the AUTHORITY setting.
- Press the UP / DOWN keys to change the setting to INST (ie. INSTALLER)
- Press the VIEW button to save the setting.
- Press BACK button twice to return to MAIN MENU

## ***PUMP PROTECTION MONITOR***

This feature monitors the amount of time the system has been in a low flow situation, and will turn off the filtration pump after a predetermined amount of time to protect the pump from damage. For systems with a sand filter we recommend a minimum of 5 minutes so that the feature does not interrupt backwashing.

To set the PUMP PROTECTION TIME period:

- Set the AUTHORITY level to INSTALLER as described above.
- From the MAIN MENU navigate to SETTINGS, and press VIEW.
- Navigate to the PUMP PROTECTION field and press VIEW to edit.
- Use the UP and DOWN buttons to adjust the time in MINUTES.
- Press the view button to save the setting.
- Press the BACK button to exit.

The pump protection feature will be enabled when the PUMP PROTECTION TIME is set to any number greater than ZERO.

To disable PUMP PROTECTION MONITOR, set the PUMP PROTECTION TIME to ZERO.

## ***PLUMBING FLUSH***

This feature is automatic, no programming or adjustments are necessary. When in AUTO mode, the cell power will automatically switch off 30 seconds before the pump to ensure cell housing and plumbing is flushed of concentrated chlorine. This unique feature prevents high chlorine levels in the pipework diffusing through and corroding heater tube bundles and the possibility of damaging other sensitive equipment up-stream of the cell.

## **HYDROGEN GAS SAFETY**

You may take comfort from the fact that the Pool Lab Cell has worldwide patents on its design relating to safety.

### **Pool Lab has the worlds safest Cell**

Your Pool Lab Chlorinator must be installed in accordance with the installation instructions listed in this manual.

The cell, apart from producing chlorine, produces a byproduct gas Hydrogen. Hydrogen is not readily dissolved in the water and under normal filtration conditions passes through and out of the pool returns, harmlessly dissipating into the atmosphere.

If however the water flow is restricted (blocked skimmer box or filter, incorrectly closed valve, etc) then these gases can collect in the system. A potentially explosive mixture could result under certain conditions.

The Pool Lab chlorinator has eliminated this potential hazard with in-build electronic and physical safety features.

Primarily it is important that whenever chlorine is produced that we have water flow to transport the byproduct hydrogen gas through the return pipes, to the eyeball returns and to atmosphere. We have three mechanisms that ensure this occurs:

- If the water flow stops, or slows to the point where hydrogen gas is not being expelled from the cell housing, then the sensor at the top of the chlorinator cell detects this, and switches power off to the cell. The unit remains on standby until correct water flow is re-established. A message Low Flow – OFF is displayed on the LCD.
- It is an installation requirement that the filter pump is electrically interconnected with the chlorinator and operating from the one time clock. This ensures simultaneous operation of the filtration pump and the chlorine cell.
- The most important hydrogen gas containment feature is the Pool Lab's physical cell design. It's unique patented vertical design ensures that even in the unlikely event that the electronic flow protection features fail, the gas will be contained to a volume of less than 2lts within the cell housing. In this situation, no more gas can possibly be produced, since the electrode plates are no longer in contact with the water.

# DIAGNOSTIC MESSAGES

Diagnostic messages will be displayed on the bottom line of the LCD when in HOME VIEW. The messages and their meanings are explained below, with some basic tips to rectify the issue if necessary. If the problem persists, consult the troubleshooting guide for more information.

## ***CHECK SALT***

The system has detected unusually low conductivity in the cell, possibly due to a low salt level, and is running inefficiently. The system will continue to run as normal, but may not be able to produce chlorine to its full potential. This can also be caused by very cold water, in which case the message can generally be ignored.

- Check the salt level, and add salt if required
- Inspect the cell for debris or calcium scale

## ***CHECK SALT CELL OFF***

The system has detected critically low conductivity in the cell, possible due to a very low salt level. Power to the cell has been turned off to prevent damage. The filtration system will run as normal, but no chlorine will be produced. Once every five minutes, the system will re-check and resume normally if the condition is rectified.

- Check the salt level, and add salt if required
- Inspect the cell for debris or calcium scale

## ***HIGH SALT***

The system has detected unusually high conductivity in the cell, possibly due to a high salt level. Usually no user action is required, this is just a warning not to add any more salt. Chlorine can still be produced efficiently, but it is nearing the threshold where it could trigger HIGH SALT CELL OFF. This message is more likely to appear at higher water temperatures.

- Check the salt level, and top up the pool with fresh water if possible
- DO NOT ADD SALT

## ***HIGH SALT CELL OFF***

The system has detected critically high conductivity in the cell, possibly due to a very high salt level, or a combination of high salt and high water temperatures. Power to the cell has been turned off to prevent damage. The filtration system will continue to run as normal, but no chlorine will be produced. Once every five minutes, the system will re-check and resume normally if the condition is rectified.

- Check the salt level, and top up the pool with fresh water if possible
- DO NOT ADD SALT
- If the salt level is significantly too high, it may be necessary to drain some water and top up with fresh water.

## ***PUMP PROTECTION ACTIVE***

The system has detected a low flow condition for longer than the time specified in the PUMP PROTECTION TIME setting. The pump has been turned off, and will not restart until the filtration mode is changed manually.

- Press the MODE button to toggle the filtration mode back to AUTO or ON.
- Refer to LOW FLOW recommendations below.

## ***LOW FLOW***

The system has detected a low flow condition, and will not be producing any chlorine.

- Check visually for water flowing through the cell. An air or gas pocket at the top of the cell housing indicates that there is not enough flow.
- Inspect the cell for debris or calcium scale
- Check skimmer baskets and pump baskets, empty them if required.
- Backwash the filter if necessary - (sand filters only)
- Clean the filter cartridge(s) if necessary – (cartridge filters only)
- Check all valve positions are correct.

## ***SPA FLOW DETECTED***

The system has detected spa flow. Chlorine production will be halted to prevent over chlorination of the spa.

## ***DEFAULTS USED***

The system could not read valid user settings from EEPROM memory, therefore factory default settings have been loaded. It is normal for this to occur on a new unit at initial power up, or after a memory reset. Otherwise it could indicate that the memory was somehow corrupted, for example if power was cut whilst a changed setting was being saved to memory. Although it would be extremely rare for this to occur.

## ***MEMORY FAULT***

The system could not successfully write to and read back from the internal memory. This generally indicates a major fault with the PCB, and it is likely that user settings, timers, running modes, etc. may not be able to be saved. Operation of the unit could be unpredictable. Try to cycle power to the unit off, and back on again. If the problem persists – return the unit for service.

# CHLORINE PRODUCTON AND CONTROL

## ***FREE CHLORINE LEVEL***

**A free chlorine residual of 1.0ppm to 3.0ppm must be maintained in the pool / spa water at all times.**

The ability of the chlorine generator to maintain this level will alter with respect to the chlorine demand imposed by bather load and environmental factors.

The chlorine output level [%] is displayed on the LCD and may be altered using the UP and DOWN buttons. This allows you to increase or decrease the chlorine production without alteration of the operation time.

Testing for chlorine levels is very important and should be performed on a daily basis. The sample of water to be tested should be taken at arms depth away from the pool returns. This avoids highly chlorinated water, which has traveled directly from the chlorinator cell and ensures the reading will be a true representation of the pools residual level.

The requirement to super chlorinate or shock dose the pool manually during periods of high chlorine demand is highly recommended, and in some cases absolutely necessary.

When a test reveals low chlorine (or zero) chlorine, always treat manually with liquid chlorine and investigate if the chlorine generator is operating to its maximum capacity and for sufficient hours to meet the demand.

Contrary to popular belief, a Chlorine generator can not shock dose the pool water. It is however beneficial especially where high bather loads exist to perform this task. Shock dosing the water manually with chlorine, breaks irritating chloramines down and provides for safer water with reduced chlorine demand.

## ***ALTERING CHLORINE OUTPUT***

The chlorine output may be altered in two ways:  
Increasing or decreasing the operating time  
Increasing or decreasing the output percentage level

Manual addition of liquid chlorine may be required during peak usage periods if the chlorinator cannot meet the demand.

# **WATER BALANCE**

The balance of your pool water is no less critical because you have installed a salt chlorinator. All the parameters relating to water balance in Pool and Spa water must be constantly checked and adjusted.

We strongly recommend you seek advice from a pool professional regarding the balancing of water for your pool. A correctly balanced pool will protect it and the equipment from chemical damage and ensure bathers are swimming in clean clear healthy pool water.

## ***pH***

A high pH will reduce the effectiveness of chlorine, potentially cause scale on both the pool and the equipment, and irritate bathers. A low pH may cause the water to become corrosive, damaging the pool interior finish, equipment (heat exchangers especially) and also irritate bathers. Each pool finish and type has a specific range in which the pH should remain. Generally a pH of between 7.2 – 7.6 is suitable for most pool types, however those requiring a higher pH will also require a higher chlorine residual. (Consult with your pool shop)

## ***TOTAL ALKALINITY***

The total alkalinity is a measurement of all the alkalis in your pool water, (Carbonates, Bicarbonates and Hydroxides). When adjusted within the accepted levels, T.A. acts as a pH buffer, resisting changes to the pH level. The recommended T.A. level of your pool may vary from 80ppm – 120ppm depending on the pool finish, consult with a pool water professional for advice on the recommended range for your pool.

## ***CALCIUM HARDNESS***

The hardness of your pool water is very important in controlling scale and the corrosive effects of water. A low calcium level may cause pool water to become corrosive even if the pH is within its recommended range. A sign of this is brown stains on the pool finish and in adjoining Spas especially. This is metal staining, the source of which is usually the heater. A high calcium level may cause pool water to deposit scale, even if the pH is within its recommended range. The salt chlorinator cell may require very frequent cleaning and scale may deposit on pool finish and equipment. Generally a level of 100ppm – 200ppm is recommended. Consult with your pool builder or pool shop for specific advice on the correct level for your pool.

## ***SALT LEVEL***

The salt level in pool water is usually approximated either by measuring the conductivity of the water, or by using a test strip or reagent kit. Sometimes also referred to as T.D.S. Total Dissolved Solids, or salinity, which while technically slightly different are all close enough approximations for the range used in pool water. With a salt chlorinator, it is essential to have approximately the correct amount of salt in the water to achieve the conductivity required for the chlorine cell to work efficiently.

Pool Lab recommend using regular pool salt (Sodium Chloride).

## **CHLORINE STABILIZER – CYANURIC ACID**

The sun's ultraviolet light breaks down chlorine rapidly, so in domestic applications it is highly beneficial to use a chlorine stabilizer in pools with exposure to the sun. Indoor pools will only benefit if there is direct sunlight on the water for a significant part of the day.

The importance of its use is such that our range of chlorinators are sized with the express requirement that chlorine stabilizer be used as per the directions. Cyanuric acid or chlorine stabilizer, when dissolved in the pool water to achieve levels of between 40ppm to 80ppm will effectively reduce the breakdown of chlorine by ultraviolet light.

Higher stabilizer levels (greater than 100ppm) may in fact be detrimental to the pool water, and will actually stop the chlorine from killing bacteria and algae effectively. Consult with your local pool professional for the appropriate amount to use in your pool.

## **Combined Chlorine - Chloramines**

A common cause for unusually high chlorine demand is the presence of chloramines in the pool water, detectable when a Total Chlorine test result is higher than a Free Chlorine test result by greater than 1.0ppm. The difference between these two test results is known as the "Combined Chlorine". More advanced test kits will include the Total Chlorine test, otherwise you will need to have your water tested professionally to check for this.

*Chloramines are formed when free chlorine reacts with ammonia like compounds called 'amines', and this will build up over time. Chloramines are a poor disinfectant and also reduce the disinfecting power of the free chlorine in the water. Chloramines are irritating to the eyes and respiratory system, and are responsible for the "chlorine smell" most noticeable around heavily used indoor pools.*

As a general rule Pool Lab recommend shock dosing your pool with liquid chlorine at least once every swim season as this can significantly reduce chlorine demand and greatly improves the disinfecting power of the free chlorine in the water. For pools with heavier bather loads this may need to be done more often.

An accurate measurement of the pool volume and combined chlorine level is essential for calculating the required amount of chlorine to perform the shock dose.

**You should consult your local swimming pool professionals for advice on this procedure, and how often is appropriate for your pool.**



## High Calcium (Hard) water sources – the Langlier Saturation Index

The Langlier Saturation Index (Si) is a relationship between the Calcium Hardness, Total Alkalinity, pH and water temperature. When the water is balanced correctly, the Si value should be somewhere between -0.2 and +0.2. A value lower than -0.2 indicates the water is corrosive, and a value higher than +0.2 indicates the water is scaling.

If you are in a situation where the water source for the pool contains a higher level of calcium than is recommended for you pool, then this index can be very useful. It will allow you to find a pH value that will not be corrosive or scale forming, and this pH value will generally be slightly lower than what would normally be recommended for your pool.

The following formula and reference chart can be used to find the current Si for your water. You will need to know the pH level, Total Alkalinity, Calcium Hardness and Temperature of your water.

Use the chart to determine the values for Ti, Ci, and Ai, and insert these values into the formula, along with the measured pH value to determine your Si value.

If you get an Si value higher than +0.2, then your water is scaling. In this case you should reduce the pH in your water by the value of Si to ensure your water is neither scaling or corrosive.

$$Si = pH + Ti + Ci + Ai - 12.1$$

Temperature Degrees C	Ti	Calcium Hardness	Ci	Total Alkalinity	Ai
12	0.3	75	1.5	75	1.9
16	0.4	100	1.6	100	2.0
19	0.5	125	1.7	125	2.1
24	0.6	150	1.8	150	2.2
29	0.7	200	1.9	200	2.3
34	0.8	250	2.0	250	2.4
39	0.9	300	2.1	300	2.5
		400	2.2	400	2.6
		600	2.4	600	2.8
		800	2.5	800	2.9

Example:

**pH = 7.6, Temp = 24 (Ti = 0.6), Calcium = 400 (Ci = 2.2), Alkalinity = 125 (Ai = 2.1)**

$Si = 7.6 + 0.6 + 2.2 + 2.1 - 12.1,$

$Si = +0.4,$  so the water is scaling.

In this case we would take 0.4 away from the measured pH to find the ideal pH is 7.2. A pH value anywhere between 7.0 and 7.4 would be acceptable in this case.

# WATER CIRCULATION

In general the total volume of swimming pool water should be turned over at least 1.5 to 2.0 times per day through the filtration system. Where traditional single speed pumps are used, this is normally achieved within an 8 hour period.

With the introduction of energy efficient multi-speed and variable speed pumps it has become more complicated than just running the pump for a certain amount of time.

It is important to ensure you are maintaining at least the minimum daily turnover of water. If using a multi or variable speed pump at low speed, you may need to consult the pump documentation to help determine the approximate flow rate you have.

If daily turnover is not maintained the chemical and sanitizer distribution in the water may not be uniform, and water test samples may not be representative of the entire pool volume. This can make chemical dosing inaccurate, and can increase the chance of forming black-spot algae on your pool surfaces.

See examples below:

## **Traditional Fixed Speed Pool Pump**

Pool Volume:	50,000 Litres
Pump Rated Flow:	210 LPM (Litres per minute)
Turnover Rate:	approx. 4 hours. (238 minutes)
Time to turn over 1.5 x pool volume:	approx. 6 hours (357 minutes)
Time to turn over 2.0 x pool volume:	approx. 8 hours (476 minutes)

## **Energy efficient Variable Speed Pump, operating at approx ½ flow rate**

Pool Volume:	50,000 Litres
Pump Approximated Flow:	<b>105 LPM (Litres per minute)</b>
Turnover Rate:	approx. 8 hours. (476 minutes)
Time to turn over 1.5 x pool volume:	approx. 12 hours (714 minutes)
Time to turn over 2.0 x pool volume:	approx. 16 hours (952 minutes)

This example illustrates that when you halve the flow rate, you effectively need to double the filtration time.

When performing manual pH and chlorine tests for comparison with ASP results, always obtain the sample as close as possible to the filtration system inlet – usually the skimmer box. This place will be most representative of the readings acquired by the Pool Lab ASP. Also ensure the displayed results are up-to-date by initiating a water test via the ASP TOOLS menu.

# INSTALLATION

## ***PLUMBING***

### **Cell Installation**

The Cell housing must be installed vertically with the inlet and discharge plumbing positioned such that the water enters and exits the cell chamber at the lowest point of the vertical cell.

50mm pipe must be plumbed directly onto both ends of the cell with the water flowing in the direction as indicated by the arrow on the cell housing.

50-40mm reducing bushes will be required for 40mm plumbing.

Do not use barrel unions directly on both sides of the horizontal plumbing that connect to the cell housing. Unions may loosen and cause the cell to rotate from a vertical upwards position which will disable the physical ability for the cell to contain a hydrogen gas build up.

Barrel unions can be used, but must be arranged so that the cell cannot rotate if they are loosened. For example, if at least one of the unions is on a vertical or perpendicular pipe leading to the cell.

### **Positioning the Cell**

The cell must be installed on the pool return line, DOWN STREAM of all other equipment such as the filter, heaters and solar heaters. This is very important in preventing accumulation of Hydrogen gas as well as corrosion of equipment such as a heat exchange. Where the cell is installed below pool water level, ensure isolating valves are installed somewhere either side of the cell, so it can be inspected or removed.

# Plumbing Example

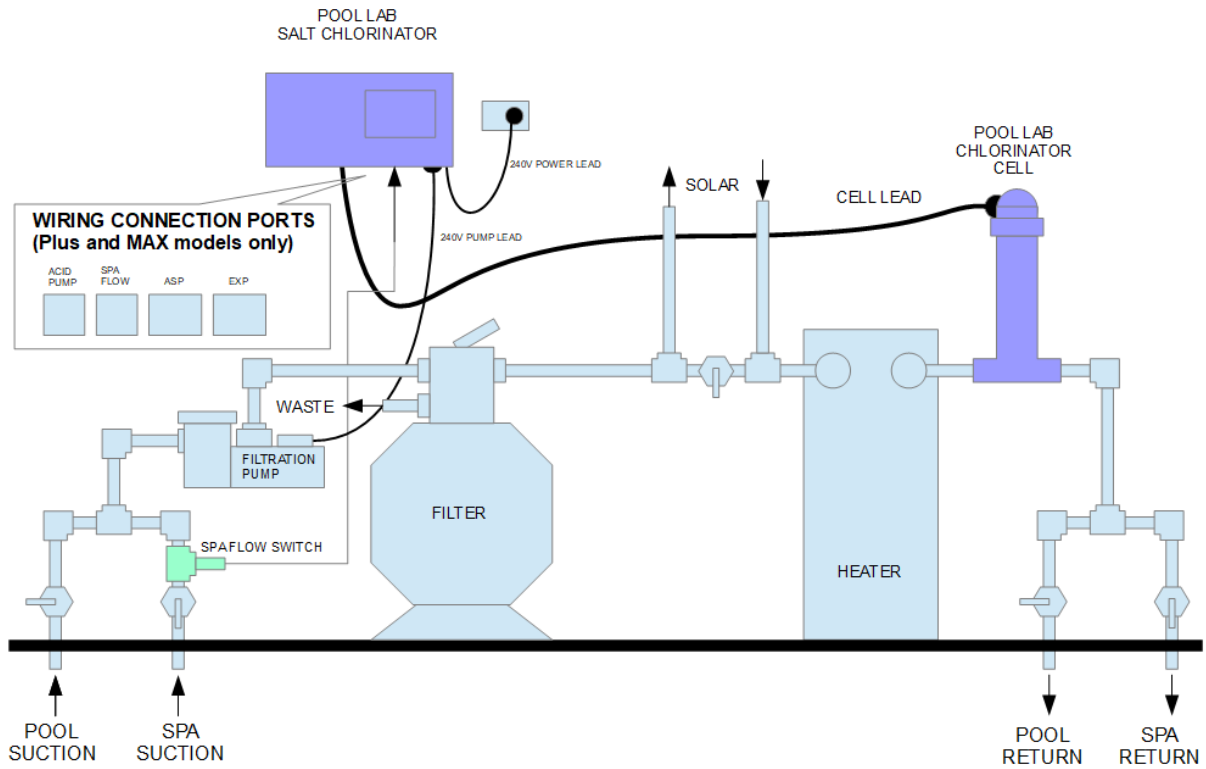

**Air Blower Installation** – If an air blower is installed and connected directly to venturi spa jets, then a vented loop must be installed. This allows any potential build up of hydrogen gas to escape from the blower line before it comes in contact with the blower motor.

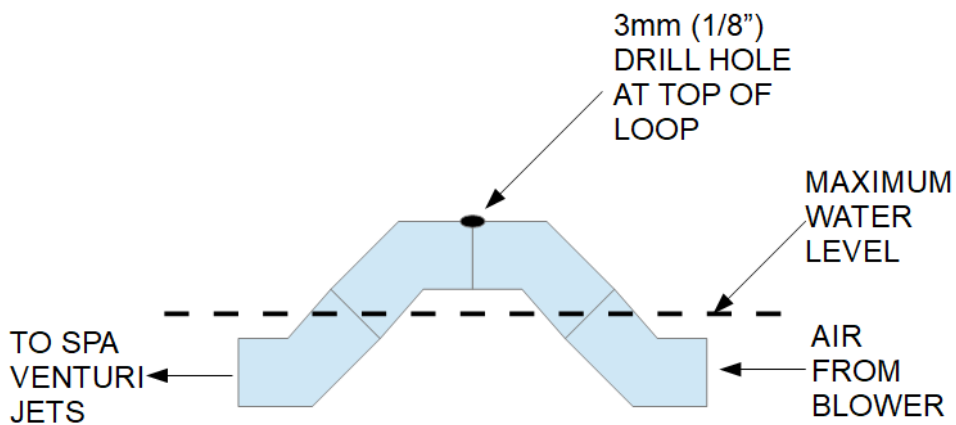

**NOTE:** The top of the loop must be above the maximum water level in the spa.

## **POWER SUPPLY AND CONTROLLER**

The Pool Lab power supply and controller is supplied with a mounting bracket, three screws and three masonry plugs. To comply, the unit must be mounted on a solid wall or post that covers an area no less than the rear area of the back of the power pack. Always mount the power pack as per local electrical codes and within 3m (9 feet) of the cell and 2m from the pool pump. Air flow around the power supply must not be restricted or close to any heat source such as a gas heater exhaust.

The unit is suitable for outdoor installation and has an IP23 rating. This allows the unit to be installed either 1.2m higher than the highest water level or at least 3m from the pool edge as defined in AS3000 section G.3.

The power supply and controller has a built in digital time clock which will control both the chlorinator and pump ON and OFF times. For the built in safety features and timers to operate correctly the pump should be connected directly to the pump outlet socket on the bottom of the unit.

You may use an external time clock to control the chlorinator and pump, however some of the delay features involving the pump will not operate.

**WARNING** - ISOLATE AND DISCONNECT SUPPLY POWER BEFORE SERVICING CHLORINATOR OR PUMP.

**CAUTION** - FOR CONTINUED PROTECTION AGAINST POSSIBLE ELECTRIC SHOCK USE ONLY IDENTICAL REPLACEMENT PARTS WHEN SERVICING.

# SALT

- ONLY USE APPROVED POOL GRADE SALT THAT IS SPECIFICALLY LABELLED FOR SWIMMING POOL AND SPA USE
- SALT MUST BE GREATER THAN 99% PURE
- DO NOT USE ROCK SALT, SALT WITH YELLOW PRUSSATE OF SODA, SALT WITH ANTI-CAKING ADDITIVES OR IODIZED SALT.
- ADD SALT TO POOL WATER AS FAR AWAY FROM THE FILTRATION SYSTEM SUCTION POINTS AS POSSIBLE.
- CLOSE MAIN DRAIN VALVE WHERE APPLICABLE BEFORE ADDING SALT FOR AT LEAST 24 HOURS
- REMOVE ANY SUCTION DRIVEN POOL CLEANERS FROM THE WATER FOR AT LEAST 24 HOURS.

## INITIAL SALT DOSING – IDEAL SALINITY 3000ppm

Do not assume a pool full of water whether it is new or old has a zero salinity. A substantial amount of salt may be present in the water if the pool was previously treated with liquid chlorine or if the pool is filled by a water source high in salt. Depending on the geographical area, the tap water may have a high salinity level.

It is important to test the water first before calculating the initial salt dosage or you may over-salt the pool water.

Use the SALT ADDITION TABLE on the next page to quickly calculate the amount of salt required to bring your water to the ideal salinity level of 3000ppm. You will need to know your current salinity level in parts per million (ppm) and your pool water volume in Litres.

*Please note: Although the salt chlorinator diagnostics will advise when to add salt and when not to add salt, you must always perform a salt test using a test kit or salinity meter to confirm the findings before making a salt addition.*

## SALT ADDITION TABLE

The Ideal Salinity Level for all Pool Lab Salt Chlorinator models is 3000ppm.

Use the table below to calculate the amount of salt required to bring your water to the ideal salinity level.

Current Salt Level (ppm)	Pool Volume (Litres)									
	10000 L	20000 L	30000 L	40000 L	50000 L	60000 L	70000 L	80000 L	90000 L	100000 L
0	30 kg	60 kg	90 kg	120 kg	150 kg	180 kg	210 kg	240 kg	270 kg	300 kg
250	28 kg	55 kg	83 kg	110 kg	138 kg	165 kg	193 kg	220 kg	248 kg	275 kg
500	25 kg	50 kg	75 kg	100 kg	125 kg	150 kg	175 kg	200 kg	225 kg	250 kg
750	23 kg	45 kg	68 kg	90 kg	113 kg	135 kg	158 kg	180 kg	203 kg	225 kg
1000	20 kg	40 kg	60 kg	80 kg	100 kg	120 kg	140 kg	160 kg	180 kg	200 kg
1250	18 kg	35 kg	53 kg	70 kg	88 kg	105 kg	123 kg	140 kg	158 kg	175 kg
1500	15 kg	30 kg	45 kg	60 kg	75 kg	90 kg	105 kg	120 kg	135 kg	150 kg
1750	13 kg	25 kg	38 kg	50 kg	63 kg	75 kg	88 kg	100 kg	113 kg	125 kg
2000	10 kg	20 kg	30 kg	40 kg	50 kg	60 kg	70 kg	80 kg	90 kg	100 kg
2250	8 kg	15 kg	23 kg	30 kg	38 kg	45 kg	53 kg	60 kg	68 kg	75 kg
2500	5 kg	10 kg	15 kg	20 kg	25 kg	30 kg	35 kg	40 kg	45 kg	50 kg
2750	3 kg	5 kg	8 kg	10 kg	13 kg	15 kg	18 kg	20 kg	23 kg	25 kg
3000	IDEAL	IDEAL	IDEAL	IDEAL	IDEAL	IDEAL	IDEAL	IDEAL	IDEAL	IDEAL
3250	OK	OK	OK	OK	OK	OK	OK	OK	OK	OK
3500	HIGH	HIGH	HIGH	HIGH	HIGH	HIGH	HIGH	HIGH	HIGH	HIGH
3750+	DILUTE	DILUTE	DILUTE	DILUTE	DILUTE	DILUTE	DILUTE	DILUTE	DILUTE	DILUTE

# TROUBLESHOOTING

SYMPTOM / DISPLAY MESSAGE	POSSIBLE CAUSES	POSSIBLE SOLUTIONS
No Display	No Power	Check for power at socket
	External Timer	An external timer (if fitted) may not be providing power
	Internal Fuse	Return unit for servicing
Unit resetting, or power cycling	An excessively high salt level may cause the power supply to shut down to protect from overload.	Check salt level in water. If salt level is too high you may need to pump some water to waste and then top up pool with fresh water. Consult your local swimming pool professionals for advice on this procedure.
	Short circuit in cell	Disconnect cell lead from cell. If the problem does not occur with the lead disconnected then this may indicate a short circuit in the cell. Check cell for damage such as displaced or touching plates. Also check for metallic debris that may be causing a short circuit.
	Short circuit in cell lead, faulty power supply, or faulty PCB.	If the problem persists with the cell lead disconnected then the unit will need to be returned for servicing.
Display Message: "PUMP PROTECTION ACTIVE"	Low flow was detected for longer than the time specified in the settings	Restart pump by pressing the MODE button, and select either AUTO or ON mode as required. See LOW FLOW message below for further instructions.
	If this occurs during backwashing, rinse or while pumping to waste.	The cell cannot detect flow whilst water is not returning to pool. Extend the PUMP PROTECTION TIME to suit your needs, or disable it by setting to ZERO. If pumping large amounts of water to waste it is recommended to disconnect the chlorinator and connect the pump directly to mains power for this procedure.
	Cell not connected	Pump protection will activate if the cell lead is not connected. Disable pump protection to override this (if intentional), or reconnect the cell lead.
Display Message: "LOW FLOW (CELL)"	Cell does not have enough water flow to evacuate gas. (Evident by an air pocket at the top of the cell)	<ul style="list-style-type: none"> <li>Check skimmer baskets for debris</li> <li>Check pump basket for debris</li> <li>Backwash Filter (sand filter)</li> <li>Clean Filter Cartridges (cartridge filter)</li> <li>Check valve positions</li> <li>Check for debris or obstruction in cell</li> <li>Check water level</li> </ul>
	Leak on suction side of pump Plumbing leaks on the suction side of the pump can cause air to be pushed through the filtration system, which both reduces flow significantly and creates air pockets that can become trapped in the cell.	

<b>SYMPTOM / DISPLAY MESSAGE</b>	<b>POSSIBLE CAUSES</b>	<b>POSSIBLE SOLUTIONS</b>
Display Message: "CHECK SALT"	Salt level too low	Check salt level and add salt if required.
	Temperature too low	When water temperature is below 25°C the cell may not be able to produce at 100%.
	Calcified or blocked cell. Visually inspect cell for a build up of white calcium or other deposits / debris between plates.	Refer to CELL MAINTENANCE section.
Display Message: "CHECK SALT (OFF)"	Very low salt level, unit will not produce chlorine to protect cell from damage	Check salt level and add salt if required.
	If salt level and water temperature are normal and cell is clean, this may indicate a worn cell.	Have cell checked and replace if necessary
Display Message: "HIGH SALT"	Salt level too high	This is a warning only. Chlorinator will be operating normally unless the "HIGH SALT (OFF)" message is displayed (see below). Do not add any more salt. Top up pool with fresh water if possible.
	High Water temperature	A combination of a high salt level and high water temperature can trigger this warning. No action is required unless the "HIGH SALT (OFF)" message is displayed (see below).
Display Message: "HIGH SALT (OFF)"	Very high salt level detected, possibly combined with high water temperature. Cell has shut down to protect from damage.	Check salt level in water. If salt level is too high you may need to pump some water to waste and then top up pool with fresh water. Consult your local swimming pool professionals for advice on this procedure.
Display Message: "SPA FLOW DET'D"	The flow switch on the spa suction line triggers this message. This message indicated chlorine production is inhibited while the spa is in use to prevent over chlorination.	No action required if valves are intentionally positioned to circulate spa water only.  If spa is not in use, check that the spa suction line valve is positioned correctly (closed).
	If the spa suction line valve is closed and has no flow, then the spa flow switch may be jammed or faulty	The flow switch can become jammed or broken if an object or debris is allowed to enter the spa suction line. You may require a technician for assistance.



SYMPTOM / DISPLAY MESSAGE	POSSIBLE CAUSES	POSSIBLE SOLUTIONS
<p>Display Message: "HIGH SALT/RESET"</p> <p>System resets after 30 seconds.</p>	<p>Software detected a drop in the power supply voltage. Chlorinator cell is turned off and a system reset is scheduled after a 30 second delay.</p> <p><i>This message may appear briefly when mains power to the unit is disconnected, this is normal behavior.</i></p> <p>If this message appears immediately after the addition of salt to the water it is likely that some water with a very high salt concentration has been drawn into the the filtration system.</p>	<p>This is usually caused by excessive current to the chlorinator cell exceeding the power supply limit, or can also occur if mains power is briefly interrupted. Otherwise this may indicate a faulty power supply. Check salt level in water, and check cell for debris or damage such as displaced or touching plates. If salt level is ok and problem persists, return unit for servicing.</p> <p>You may need to run the filter pump for some time without the chlorinator connected so that the newly added salt has time to dissolve and disperse into the water.</p> <p>When adding salt to the water try to ensure it is added as far away from the filtration system suction points as possible. Close main drain suction valve where applicable and remove any suction driven pool cleaners from the water.</p> <p>Never add salt directly to the skimmer</p>
<p>No residual free chlorine in water</p>	<p>Chlorinator output not high enough</p> <p>Chlorinator not running sufficient hours per day</p> <p>Chlorine demand due to sunlight</p> <p>Heavy Pool Usage</p> <p>High chlorine demand due to high total chlorine reading. (This is different to Free Chlorine)</p>	<p>Ensure chlorine output is set to 100% until chlorine residual is restored.</p> <p>Extend the running time. A minimum 8 hours per day is recommended over summer</p> <p>Ensure stabilizer level (cyanuric acid) is maintained between 40 – 80ppm. Use a pool cover when pool is not in use.</p> <p>Dose manually with liquid chlorine during peak demand periods.</p> <p>Shock dose the pool with liquid chlorine. Consult your local swimming pool professionals for advice on this procedure.</p>

*Hint: Holding the BACK button for 3 seconds from the HOME view will show detailed information on the output to the chlorine cell including VOLTAGE, AMPS, and POLARITY.*

For all models, cell voltage should be close to 24.0V (+/- 1.0 V)

For PL25, cell amps should be between 2.08A – 6.0A

For PL35, cell amps should be between 2.91A – 9.0A

For PL45, cell amps should be between 3.75A – 12A

During normal operation the cell will cycle ON and OFF over a 3 minute duty cycle to maintain the correct chlorine output (as measured in grams per hour).

Cell amps vary in relation to the salt level, water temperature and condition of the cell.

# WARRANTY INFORMATION

## DOMESTIC APPLICATIONS

- 3 Year Warranty – Parts (excluding electrolytic cell)
- 3 Year Warranty – Workshop Repair Labour
- 1 Year Warranty – In-field Labour (within 30km of an authorised service agent)
- 3 Years (up to 10,000 hours\*) Warranty – Original Electrolytic Cell
- 2 Years (up to 10,000 hours\*/\*\*) Warranty – Replacement Electrolytic Cells

## COMMERCIAL APPLICATIONS

- 1 Year Warranty – Parts (excluding electrolytic cell)
- 1 Year Warranty – Workshop Repair Labour
- 1 Year Warranty – In-field Labour (within 30km of an authorised service agent)
- 1 Year (up to 10,000 hours\*/\*\*) Warranty – Original or Replacement Electrolytic Cells

## CONDITIONS

- **In-field labour charges will apply to units installed for a period exceeding 12 months.**
- In-field labour charges may apply within the 12 month period if location is more than 30 km from an authorised service agent.
- Freight charges are the responsibility of the home owner.
- Under no circumstances shall the manufacturer be liable for incidental or consequential damages, inconvenience or expenses in connection with the removal, installation or replacement of equipment.
- Under no circumstances shall the manufacturer be liable for damage caused to persons or property as a result of use of this equipment.
- Charges will apply during the warranty period if installation or method of operation is not in accordance with **our** instructions.
- Warranty extending beyond 1 year is not transferable.
- **Purchase receipt** must be produced to claim warranty.
- The use of bore water may void warranty where not managed correctly\*\*\*, and any associated discolouration or staining is not covered by warranty.

## THE FOLLOWING INVALIDATES WARRANTY

- Incorrect installations
- Incorrect use
- Misuse
- Water in excess of 40 degrees Celcius, or lower than 0 degrees Celcius.
- Water pressure exceeding 250 kpa
- Where used for a purpose other than described in this manual
- Use of non-genuine components
- Use of chemicals or optional equipment not authorised for use by Pool Lab
- Where immediate action has not been taken to rectify a problem

*\* Cell hours are defined as the total amount of time that the cell is actively powered. This information is available in MAIN MENU – STATISTICS – CELL HOURS, and may be required for warranty claims on electrolytic cells.*

*\*\* For warranty claims on replacement electrolytic cells, proof of the accumulated cell hours at the time of installation may also be required.*

*\*\*\* Always use the Langlier Index to determine the ideal pH for bore water. Damage caused by the formation of scale is not covered by warranty.*

# NOTES