

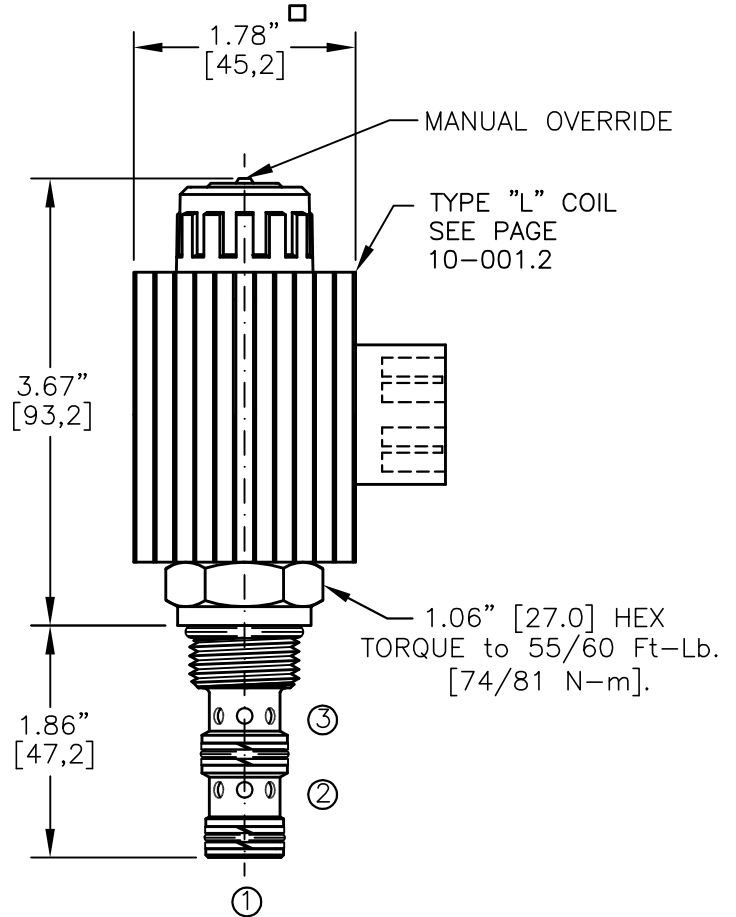

# SOLENOID VALVE 3-WAY, 2-POSITION. DIRECT ACTING, SPOOL TYPE (3/2)

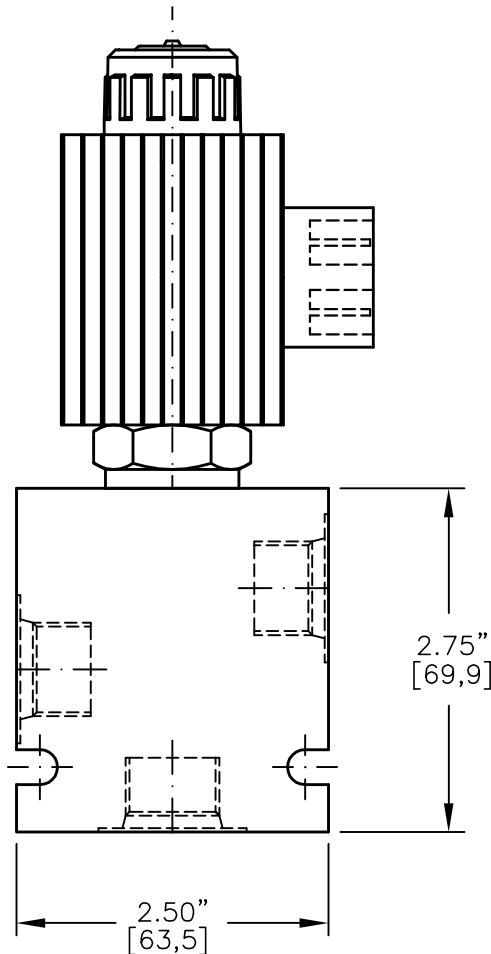
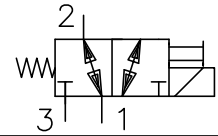

**NOTES:**

1. FOR ALUMINUM OR STEEL VALVE HOUSING CONFIGURATIONS SEE PAGE 0-032.1
2. SOLENOIDS AVAILABLE WITH DIODES - CONSULT FACTORY.
3. ALL A.C. COILS ARE INTERNALLY A.C. TO D.C. RECTIFIED.
4. FOR SOFT SHIFT SOLENOID VALVE SEE PAGE 10-002.0

### EMDV-10-X-3A-X-XXX X

<b>BASIC</b>	TERMINALS	
<b>SIZE</b>	L=18GA. 24" LEADS	
10 = 7/8"-14UNF	T=SPADE TERM.	
	B=BOLT TERM.	
<b>SEALS</b>	G=DIN43650	
N = BUNA "N"	W=WEATHER-PACK	
V = VITON	D=DEUTSCH-DT04-2P	
	M=METRI-PACK CONN.	
<b>TYPE</b>	VOLTAGE	AMPS
3A = "A" SPOOL	12D = 12 VDC	3.00
3-WAY, 2-POSITION	24D = 24 VDC	1.50
	36D = 36 VDC	1.00
	48D = 48 VDC	0.75
	110D = 110 VDC	0.33
	115A = 115 VAC	0.32
	230A = 230 VAC	0.16
<b>PORTS</b>		
0 = CARTRIDGE ONLY		
06TX = SAE - #6		
08TX = SAE - #8		
"A" = ALUM. HOUSING		
"S" = STEEL HOUSING		

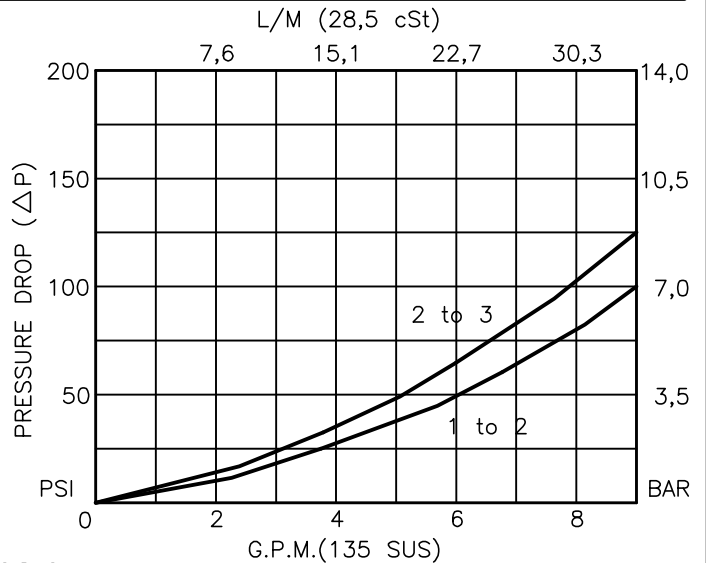



## SOLENOID VALVE 3-WAY, 2-POSITION, DIRECT ACTING, SPOOL TYPE (3/2)

### DESCRIPTION

This unit is a THREE-WAY, TWO POSITION, cartridge type, spool type, direct acting, screw in type, solenoid operated, directional control valve.

### OPERATIONS

When solenoid coil is de-energized, this valve allows flow between ports 1 and 2 and port 3 is blocked. When solenoid coil is energized, the spool in this valve is shifted and allows flow between ports 2 and 3 and port 1 is blocked. This valve shifts in a closed position. Manual Operator Standard: Push in and hold a small plunger on top of the valve with a screw driver or a similar plunger smaller than .188" dia.

### FEATURES AND BENEFITS

Continuous-duty, very low heat rise & waterproof solenoid coil. Interchangeable solenoid coils & terminations options available. Hardened precision fitted spool & sleeve provides reliable, long life. Very efficient, wet-armature solenoid core tube construction. All external carbon steel parts are plated for longer life against the elements. All cartridge valves are 100% functionally tested. Industry common cavity.

### SPECIFICATIONS

OPERATING PRESSURE: 5,000 PSI [350 Bar]

PROOF PRESSURE: 10,000 PSI [700 Bar]

FLOW: 8.0 GPM [30 l/m] See performance chart.

INTERNAL LEAKAGE: 5 cu.in/min [82 cc/m] @ 5,000 PSI [350 Bar]

VALVE HOUSINGS: 2500 PSI [175 Bar] = Aluminum - Anodized.

5000 PSI [350 Bar] = Steel - Unplated.

OPERATING TEMPERATURE: -40° to +250° F. [-40° to +120° C.]

OPERATING MEDIA: All general purpose hydraulic fluids such as MIL-H-5606, SAE-#10, SAE-#20, etc.

RESPONSE TIME: First indication of change in pressure with 100% voltage supplied @ 80% of nominal flow rating.

\* Pull-in: 50 ms

\* Drop-Out: 50 ms

SEAL KIT: SKN-1032 Buna "N"

SKV-1032 Viton

INSTALLATION: No restrictions.

WEIGHT: 1.95 lb [.88 kg] cartridge with coil only.

VALVE CAVITY: #C1030, See Page 0-032.0.