

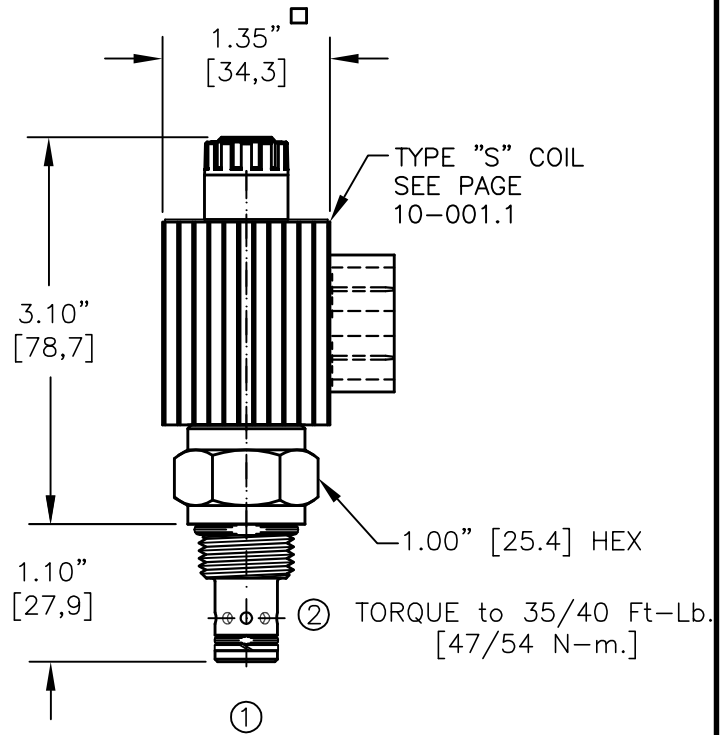

SOLENOID VALVE, NORMALLY OPEN. PILOT OPERATED, POPPET TYPE (2/2)

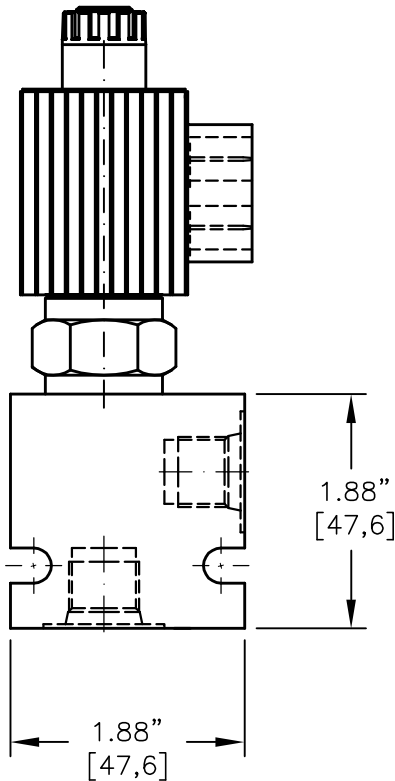
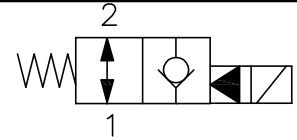

NOTES:

- 1. FOR ALUMINUM OR STEEL VALVE HOUSING CONFIGURATIONS SEE PAGE 0-011.1
- 2. SOLENOIDS AVAILABLE WITH DIODES - CONSULT FACTORY.
- 3. FOR "AC" COILS USE RECTIFIED DIN CONNECTOR 20828.

EMDV-08-X-08-X-XXX X

BASIC

SIZE
08 = 3/4"-16UNF

SEALS
N = BUNA "N"
V = VITON

TYPE
08=NORMALLY OPEN POPPET
2-WAY, 2-POSITION

PORTS
0 = CARTRIDGE ONLY
02BX = G 1/4" BSSP
06TX = SAE - #6
 "A" = ALUM. HOUSING
 "S" = STEEL HOUSING

TERMINALS
L=18GA. 24" LEADS
T=SPADE TERM.
B=BOLT TERM.
G=DIN43650
W=WEATHER-PACK
D=DEUTSCH-DT04-2P
M=METRI-PACK CONN.

VOLTAGE AMPS

12D = 12 VDC	1.7
24D = 24 VDC	.9
36D = 36 VDC	.6
48D = 48 VDC	.5
115D = 115 VDC	.2

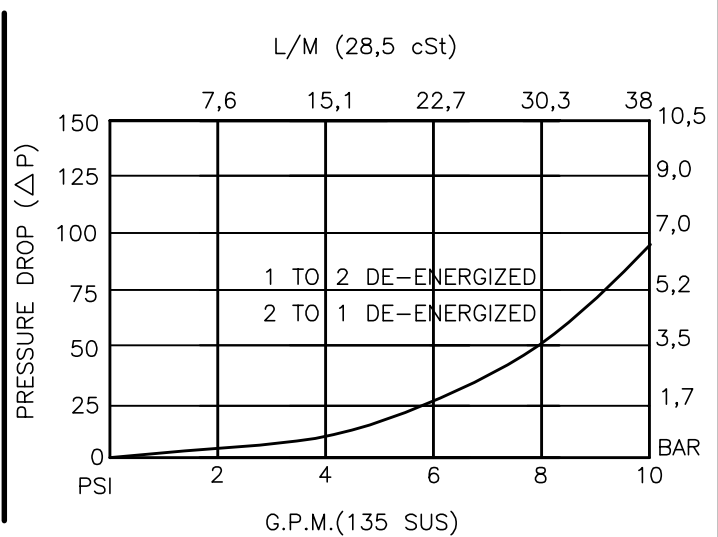



SOLENOID VALVE NORMALLY OPEN, PILOT OPERATED, POPPET TYPE (2/2)

DESCRIPTION

This unit is a NORMALLY OPEN, TWO POSITION, cartridge type, poppet type, pilot operated, screw in type, solenoid operated, directional control valve.

OPERATIONS

When solenoid coil is de-energized, this valve allows flow between ports 2 and 1 and free reverse flow between ports 1 and 2. When solenoid coil is energized, the poppet in this valve is shifted to block flow between ports 2 and 1 and reverse flow between ports 1 and 2 at a high pressure drop.

FEATURES AND BENEFITS

Continuous-duty, very low heat rise & waterproof solenoid coil. Interchangeable solenoid coils & terminations options available. Hardened precision fitted spool & sleeve provides reliable, long life. Very efficient, wet-armature solenoid core tube construction. All external carbon steel parts are plated for longer life against the elements. All cartridge valves are 100% functionally tested. Industry common cavity.

SPECIFICATIONS

OPERATING PRESSURE: 5,000 PSI [350 Bar]

PROOF PRESSURE: 10,000 PSI [700 Bar]

FLOW: 10.0 GPM [38,5 l/m] See performance chart.

INTERNAL LEAKAGE: 5 drops/min [.25 cc/m] @ 5,000 PSI [350 Bar]

VALVE HOUSINGS: 2500 PSI [175 Bar] = Aluminum - Anodized.

5000 PSI [350 Bar] = Steel - Unplated.

OPERATING TEMPERATURE: -40° to +250° F. [-40° to +120° C.]

OPERATING MEDIA: All general purpose hydraulic fluids such as MIL-H-5606, SAE-#10, SAE-#20, etc.

RESPONSE TIME: First indication of change in pressure with 100% voltage supplied @ 80% of nominal flow rating.

* Pull-in: 50 ms

* Drop-Out: 50 ms

SEAL KIT: SKN-0821 Buna "N"

SKV-0821 Viton

INSTALLATION: No restrictions.

WEIGHT: .90 lb [0.41 kg] cartridge with coil only.

VALVE CAVITY: #C0820, See Page 0-011.0.