

User Manual

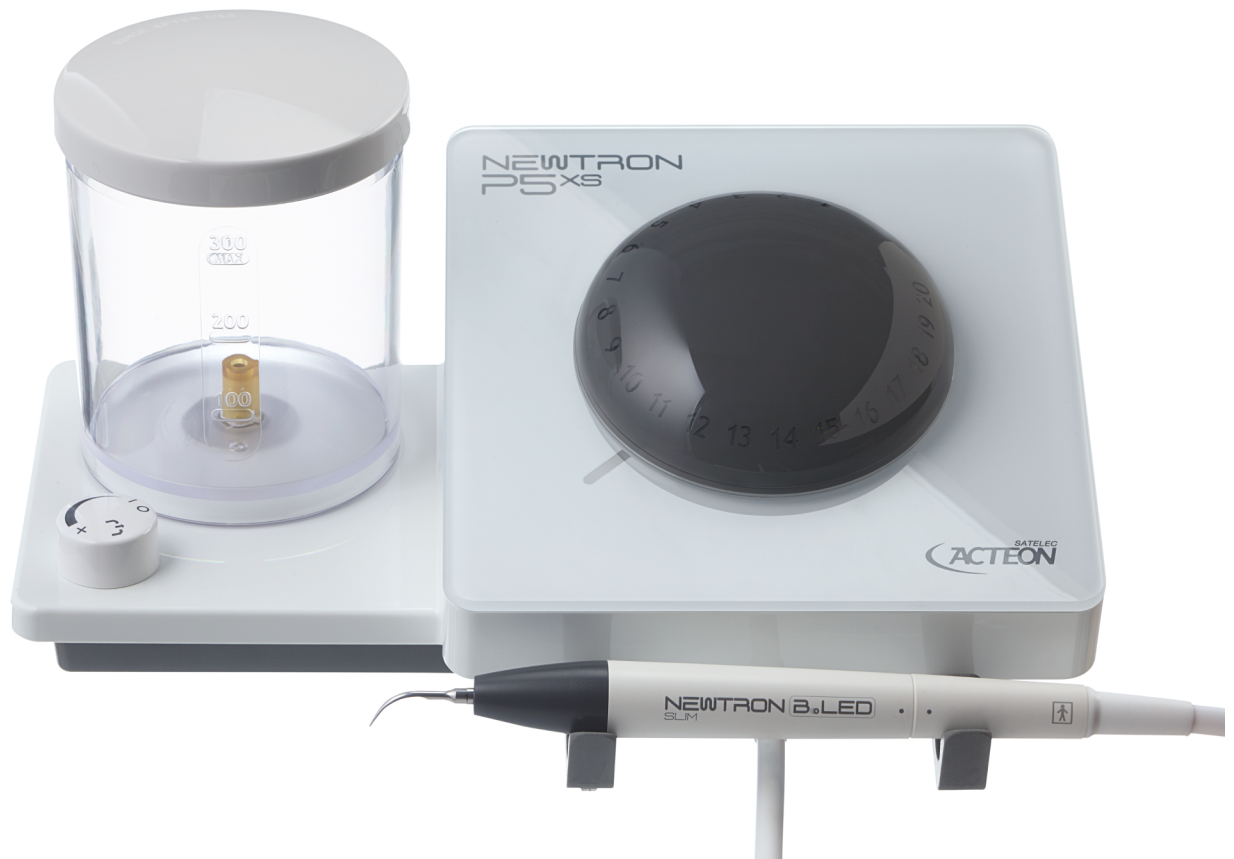

Newtron P5XS B.LED



This document is an English translation of the original French version.
Reference J62150 version V6 and drawing number NBADFR030F

Contents

1 Documentation	5
1.1 Associated documentation	5
1.2 Electronic documentation	5
2 Required information	7
2.1 Indication for use	7
2.2 Operating principle	7
2.3 Using accessories not supplied by the manufacturer	7
2.4 Connecting and disconnecting accessories during use	7
2.5 Repairing or modifying the medical device	7
2.6 Warranty	8
2.7 Latest document update	8
2.8 Date of first CE marking	8
3 Unpacking the medical device	9
4 Connect the medical device	11
4.1 Connecting the medical device to the electrical network	11
4.2 Connecting the medical device to the electrical network	11
5 Installing the medical device	13
5.1 Fixing the medical device to a non-removable support	13
5.2 Install cords	13
5.3 Installing the control pedal	13
5.4 Connecting the ultrasonic	13
5.5 Attaching a tip or a file	13
6 Dispensing a treatment	15
6.1 Accessory usage conditions	15
6.2 Preparation for use	15
7 Medical device description	17
7.1 Control unit	17
7.2 Light indicator	17
7.3 Handpiece	17
7.3.1 Handpiece cord	17
7.3.2 Handpiece support	17
7.4 Adjusts the power	17
7.4.1 Remote configuration via Bluetooth (depending on option)	17
7.5 Setting the irrigation flow	18
7.5.1 Activating the purge function/starting irrigation	18
7.6 Air inlets	18
7.7 Control pedal	18
7.8 Mains Connector	18
7.9 Switch	18
7.10 Irrigation solution tank	18
7.11 Filling the tank	18
7.12 Cassette	19
8 Disinfection and sterilising	21
8.1 Clean and disinfect the medical device	21
8.2 Cleaning, disinfecting and sterilising accessories	22
9 Monitoring and routine maintenance	23
9.1 Cleaning the irrigation system	23
9.2 Corrective Maintenance	23
9.2.1 Replacing the fuses	23
9.2.2 Replacing the irrigation cassette	24
10 Identifying incorrect operation	29

10.1 Not working	29
10.2 No spray	29
10.3 The power is not as expected	29
10.4 Ultrasounds not working	30
10.5 Water leakage	30
11 Technical specifications of the medical device	31
11.1 Identification	31
11.2 Generator	31
11.3 Length of cords	31
11.4 Irrigation	31
11.5 Footswitch	31
11.6 Environmental characteristics	31
11.7 Environmental restrictions	32
11.8 Main performance characteristics	32
12 Regulations and standards	33
12.1 Applicable standards and regulations	33
12.2 Medical class of the device	33
12.3 Symbols	33
12.4 Manufacturer identification	36
12.5 Branch addresses	37
12.6 Disposal and recycling	38
13 Index	40

Foreword

The medical device that you are about to install and use in your practice is a medical device designed for professional use. It is therefore a key tool with which you will provide treatment within the context of your work.

To ensure optimum safety for yourself and your patients, comfort in your daily practice and to benefit fully from the technology of your medical device, please read the documentation provided carefully.

Please refer to the cleaning, disinfection and sterilisation instructions for accessories and to the cleaning, disinfection and sterilisation instructions for handpieces for information about the following:

- Preparation of parts for sterilisation
- Detailed manual and automated instructions
- Information concerning conditioning for sterilisation
- Recommendations for the inspection of parts

Please refer to the instructions for the entire range of SATELEC, a company of Acteon group dental ultrasonic generators for information about the following:

- Documentation format
- Documentation archiving period
- Warnings concerning user and patient populations
- Treatment area
- Medical device usage interactions, contraindications and prohibitions
- Disposal and recycling of the medical device
- Manufacturer responsibility

Please refer to the User Manuals, Quick Start Guides and Quick Clean Guides for each medical device for information about the following:

- Unpacking and installing the medical device
- Using the medical device
- Monitoring and maintaining the medical device
- Technical specifications of the medical device

1 Documentation

This document contains the following information:

- Indications for use
- Medical device description
- Installation of the medical device
- Medical device use
- Preparation for cleaning and disinfection of the medical device
- Monitoring and general maintenance of the medical device
- Maintenance to be performed by the user

1.1 Associated documentation

This document must be used in association with the following documents:

Document title	References
General instructions relating to the complete range of dental ultrasonic generators	J00011
Cleaning, disinfection and sterilisation instructions for wrenches	J81001
Cleaning, disinfection and sterilisation instructions for tips	J02001
Cleaning, disinfection and sterilisation instructions for handpieces	J12911
Ultrasonic generator power settings table	J58000
Consulting electronic user instructions	J00007
Newtron® P5XS B.LED User Manual	J62151
Quick Clean Newtron® P5XS B.LED	J62101
Quick Start Newtron® P5XS B.LED	J62100
Newtron® P5XS B.LED application user manual	J62111
SLIM handpiece user manual	J12921

The Quick Start and Quick Clean documents are summaries created for your approval. The only binding instructions are the user manuals and regulatory documentation associated with the medical device.

1.2 Electronic documentation



The user instructions for your device are available in electronic format on the specified website and not in printed format. If the website is unavailable, try again later. You can also request a free printed copy of the user instructions within seven days via our website, by telephone or in writing.

The electronic user instructions are available in PDF format (Portable Document Format). You will need to have a PDF file reader installed to read the electronic user instructions. It is important for you to have read and understood the content of the user instructions relating to the use of your device and its accessories.

Never use your device without first reading the user instructions.

The device user instructions can be consulted at the following addresses: www.ultradent.com and www.satelec.com.

When you receive your device, you are asked to print and/or to download all documents or sections of documents that you may need to refer to in the event of an emergency, if you are unable to connect to the internet or if your electronic display tool is not working (computer, tablet, etc.). We recommend that you visit the website regularly to consult and to download the latest version of your device's user instructions. Users are asked to keep documentation close at hand for reference when necessary.

All paper or electronic documentation relating to your medical device must be kept for the device's entire service life.

Keep the original documentation for your medical device and its accessories for future reference. When loaning out or selling the medical device, the documentation must be provided with it.

2 Required information

2.1 Indication for use

This medical device is used with a dental ultrasonic handpiece to which an ultrasonic instrument is attached. It is designed for the treatment of prophylaxis, periodontics, endodontics and preservation and restoration dentistry.

2.2 Operating principle

An electrical signal emitted by the medical device is supplied to the ultrasonic handpiece. This is connected to the medical device via a cord. The handpiece comprises a piezoelectric ceramic transducer, which transforms the electrical signal into ultrasonic vibrations.

Mechanical vibrations are transmitted to a tip or a dental file attached to the end of the ultrasonic handpiece.

2.3 Using accessories not supplied by the manufacturer

The handpiece is designed to operate with SATELEC, a company of Acteon group dental tips and files. The use of tips or files made by other manufacturers will damage the handpiece, break tips and files and void the warranty.

2.4 Connecting and disconnecting accessories during use

Do not tighten or loosen the tips when the handpiece is activated.

2.5 Repairing or modifying the medical device

Contact the supplier of your device. Using the services of an unapproved repairer could render your device dangerous for you and your patients.

Do not repair or modify the device without seeking the prior permission of SATELEC, a company of Acteon group.

If the device is modified or repaired, specific checks and tests must be carried out to ensure that the medical device is still safe to use.

In the event of doubt, contact an approved dealer or the SATELEC, a company of Acteon group Customer Service team:

www.acteongroup.com

satelec@acteongroup.com

SATELEC, a company of Acteon group, at the request of technical personnel working for the network of approved dealers, will provide any information required to repair defective parts on which they may perform repairs.

2.6 Warranty

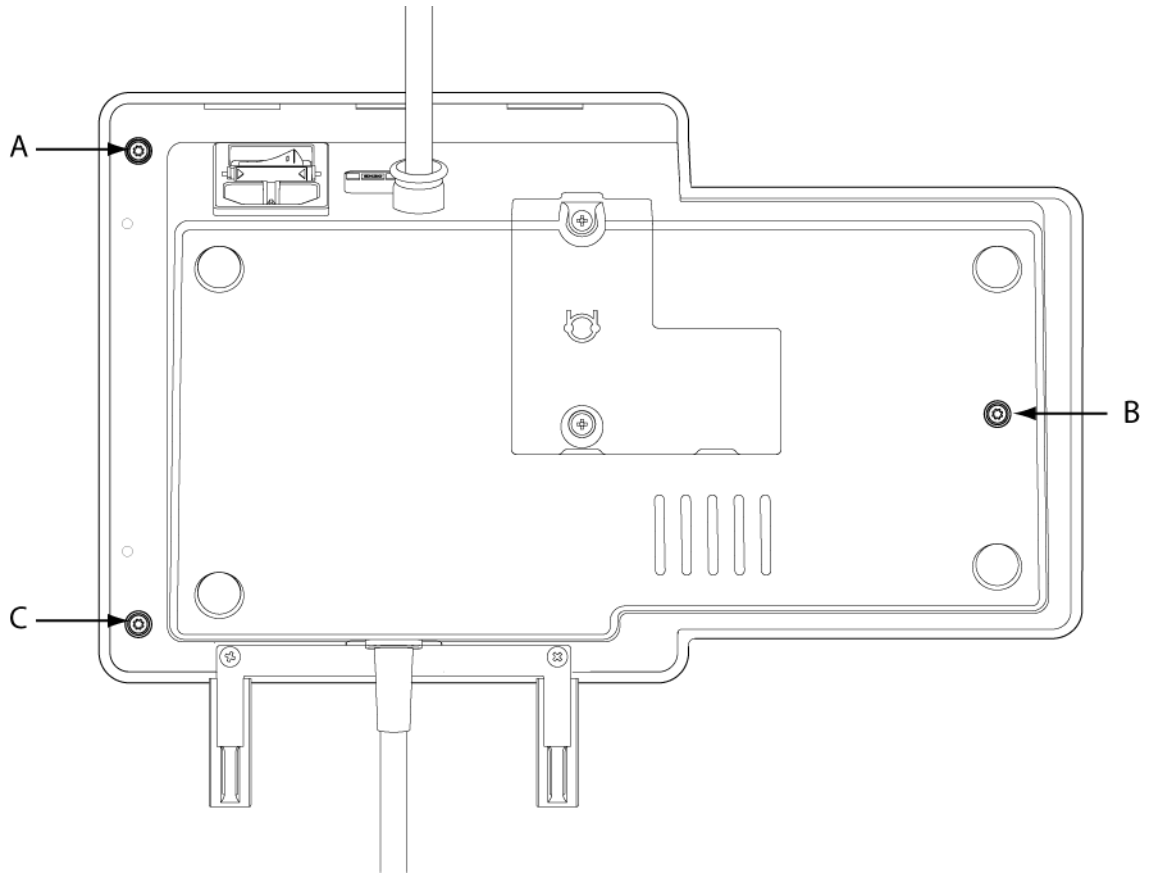

The screws marked A, B and C must not be unscrewed by the user under any circumstances as this may void the warranty for the medical device.

2.7 Latest document update

09/2017

2.8 Date of first CE marking

2013

3 Unpacking the medical device

When you receive your medical device, check for any damage that may have occurred during transportation.

If you have received this medical device by mistake, please contact the supplier to arrange for it to be collected.

If you have any questions or requirements, contact your supplier.

The Newtron® P5XS B.LED includes the following items:

- A Newtron® P5XS B.LED unit with non-detachable footswitch cord, a non-detachable handpiece cord, a 300 or 500 ml tank and a handpiece support SLIM
- A Newtron SLIM handpiece, with, depending on configuration, an installed blue LED ring, a white LED ring
- A box containing disclosing liquid F.L.A.G.™ (depending on selected options)
- A LED handpiece Quick Start-Clean guide [J12930]
- A Newtron® P5XS B.LED [J62100] Quick Start guide
- A Newtron® P5XS B.LED [J62101] Quick Clean guide
- An attachment kit
- Tips and wrenches depending on selected options
- A power cord

4 Connect the medical device

4.1 Connecting the medical device to the electrical network

Have your medical device connected to the mains power by an approved dental installation technician. Check that the mains voltage is compatible with that indicated on the medical device or its mains adapter. A different voltage would cause damage to the medical device and could injure the patient and the user. Any variation in the electrical network voltage or electromagnetic field that is non-compliant with the limits in force, could interfere with the medical device's operation.

Medical devices equipped with a protective earth must be connected to a supply network equipped with a protective earth.

Do not plug the medical device into an extension lead and do not put the mains cord in a cable cover or cable tray.

4.2 Connecting the medical device to the electrical network

1. Set the medical device's mains switch to "O" OFF position.
2. Connect the mains cord to the control unit's mains connector.
3. Connect the power lead to the mains socket.

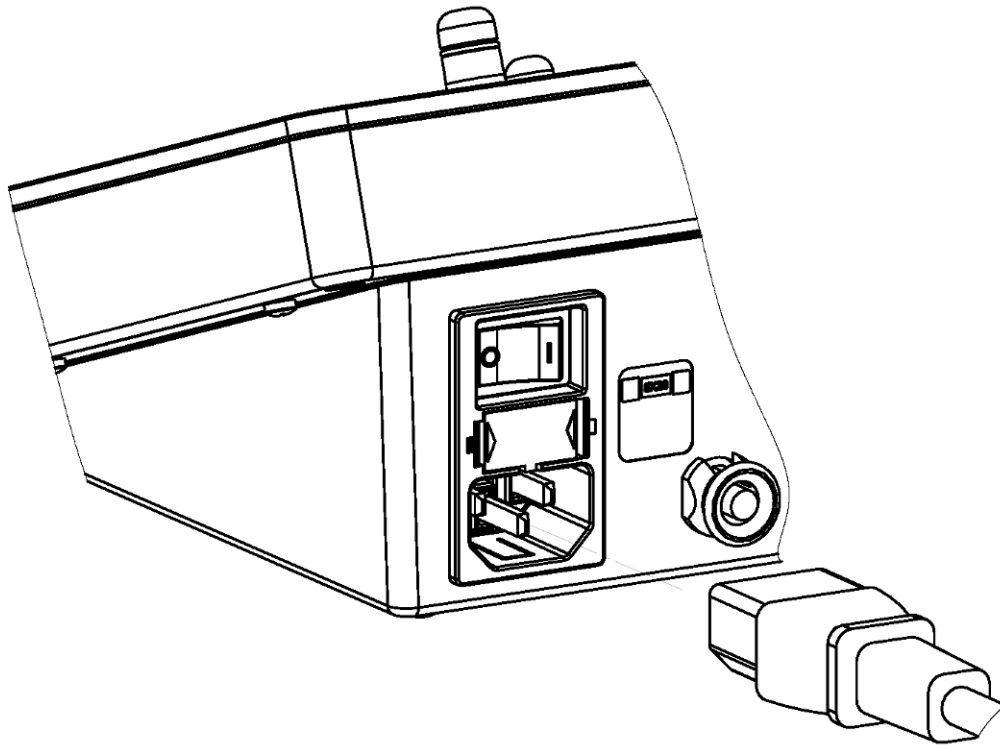

5 Installing the medical device

Place the medical device in the position that is suitable for your activity.

The medical device must be placed on a secure and flat surface or a surface with a maximum slope of five degrees.

Check that the cords do not hinder the movement or free circulation of anyone.

Adjust the position of your medical device to correspond to your angle of vision and the characteristics of your workstation, e.g. lighting or distance between the user and the medical device.

Ensure that your medical device is readily accessible. The disconnecting devices - the switch and the power plug - must be easy to access.

Do not install your medical device near or on another device.

5.1 Fixing the medical device to a non-removable support

After its initial installation, the medical device is not designed to be moved. The medical device must be fixed to ensure that it cannot be removed or moved without the use of a tool.

5.2 Install cords

Never rotate the handpiece connector on its cord as this can damage your medical device.

Never wrap the handpiece cord around the medical device.

Make sure that it is not possible to wheel over or walk on the different cords.

The cord attached to its handpiece must be easily accessible. Make sure that the cord is slack during use.

5.3 Installing the control pedal

The control pedal must be positioned near the feet of the operator and must be readily accessible.

5.4 Connecting the ultrasonic

Check for any traces of humidity on the handpiece connections. If the connections are damp, dry them with the multi-purpose syringe.

Lubricate the irrigation circuit seal located on the metal shaft on the back of the handpiece with silicone paste. This will prolong its service life and prevent leaks. Do not use spray lubricant on dental instruments.

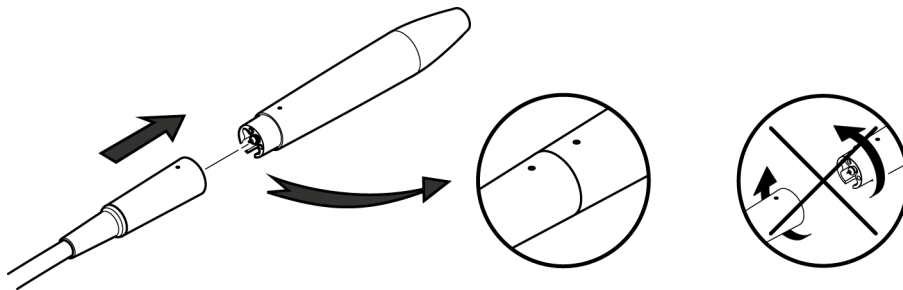

Connect the handpiece to the socket by aligning the indexing points, without rotating it.

5.5 Attaching a tip or a file

A tip or a file vibrates correctly when it is perfectly tightened without being forced beyond its stop point. Tighten the tip with the torque wrench (F81320, F81321, F81322 or F81323) to ensure optimum ultrasonic function. Over-tightening of the tip or file with the open-ended wrench can result in breakage of the tip, file or handpiece.

To prevent self-locking of the tip or the file, the latter must be removed and sterilised after each use.

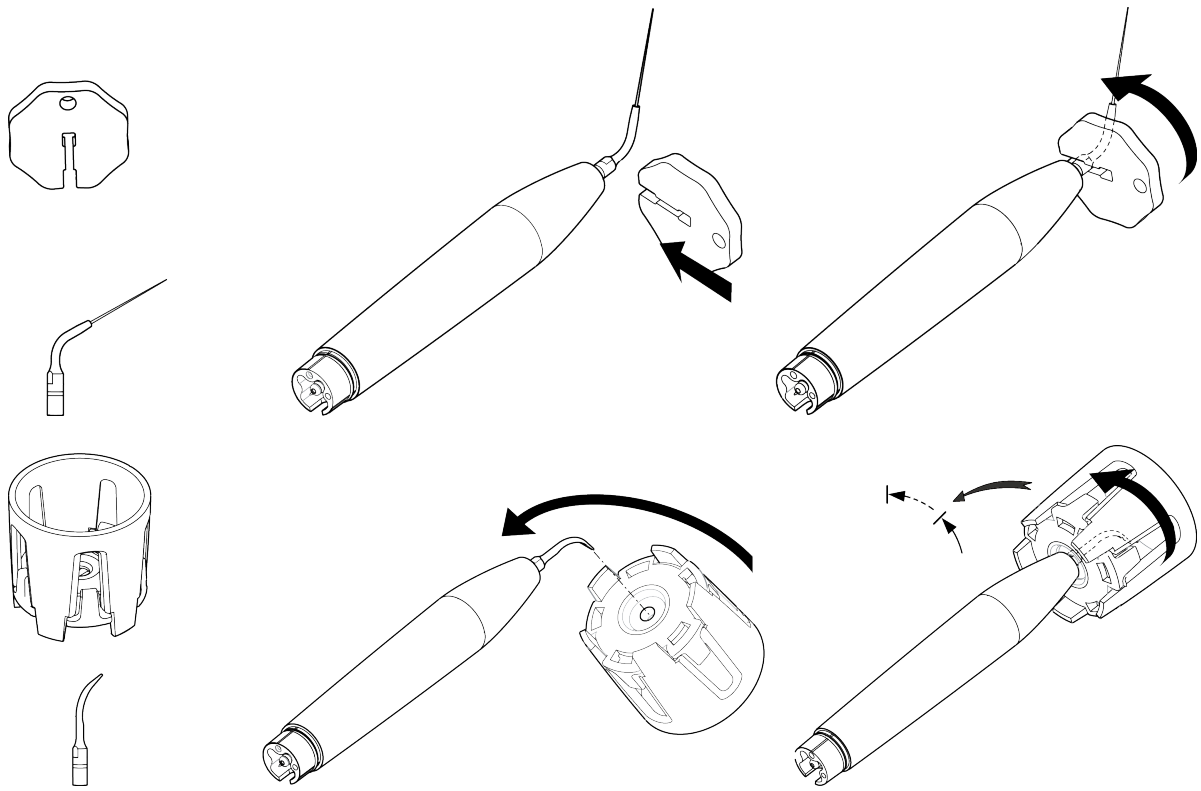

| The torque wrenches must be replaced every year.

6 Dispensing a treatment

6.1 Accessory usage conditions

The accessories and the handpiece must be cleaned, disinfected and sterilised prior to each use.



Refer to the cleaning, disinfection and sterilisation instructions for accessories listed in the chapter *Associated documentation page 5*.

6.2 Preparation for use



Protection
Glasses Needed

To prepare your medical device, follow the steps below:

1. Wear safety goggles and protective gloves.
2. Clean the unit with an alcohol disinfectant wipe.
3. Remove the handpiece from its sterilisation bag.
4. Remove the wrench from its sterilisation bag.
5. Remove the tip from its sterilisation bag.
6. Screw the tip onto the handpiece, first manually and finishing with the wrench.
7. Connect the handpiece to the handpiece cord socket.
8. Place the handpiece on its support. .
9. Switch on the medical device.
10. Check the irrigation parameters depending on the tip chosen.
11. After water drainage, check that the spray works correctly.

Your medical device is now ready to use.

7 Medical device description

7.1 Control unit

The control unit incorporates Newtron® technology patented by SATELEC, a company of Acteon group . Newtron® technology emits ultrasonic vibrations in a controlled way. Relayed by SATELEC, a company of Acteon group tips, these vibrations are used to deliver effective treatments and to ensure patient safety. The control unit incorporates an dental ultrasonic generator equipped with a piezoelectric command.

7.2 Light indicator

The light indicator is designed to provide information about the status of the medical device.

When the light indicator is illuminated, the medical device is on and ready to use.

Each colour corresponds to the power level range.

7.3 Handpiece

There is a handpiece with SLIM B.LED to white LED connector and a handpiece with SLIM B.LED to blue LED connector.

Refer to the Newtron handpiece user manual [J12921] for more information.

The handpieces are designed to operate exclusively with SATELEC dental ultrasonic generators.

7.3.1 Handpiece cord

The SLIM cord is only compatible with Acteon handpieces with SLIM connector.

The cord ensures irrigation circulation and electrical connection between the medical device and the handpiece.

7.3.2 Handpiece support

The support holds the handpiece or the cord sleeve.

The handpiece support can be fixed to the front face or the right side face of the medical device. To change the position of this support, unscrew the two screws located under the support, position the support over the two holes located on the right side face and insert and tighten the two fastening screws.

The silicone supports can be removed by sliding them along the metal rod. They can be sterilised.

7.4 Adjusts the power

The ultrasound power must be adjusted in accordance with the tip used and the required treatment. The operating power of the tips must be selected in compliance with the Acteon tips color coding system (CCS tips).

Each tip must be used in accordance with the settings defined in the ultrasonic generator irrigation and power settings table [J58000].

The ultrasound power configuration button is used to set the operating power: 1 to 20.

Rotating the button causes the colour of the medical device's backlighting to change.

- Green: 1 to 6: very low to low power, used mainly for periodontics.
- Yellow: 6 to 11: medium power, used mainly for endodontics.
- Blue: 11 to 16: high power, used mainly for scaling and preservation and restoration dentistry.
- Orange: 16 to 20: very high power, used mainly for loosening.

The ultrasound power configuration button can be removed by the user to facilitate the cleaning and disinfection of the control unit. The button cannot be sterilised.

The removal of the button inhibits the activation of ultrasounds. The top surface of the control unit lights up white and the control pedal can be pressed to activate the purge function. The purge function can be stopped at any time by pressing the control pedal again.

7.4.1 Remote configuration via Bluetooth (depending on option)

The Newtron® P5XS B.LED, depending on the option, allows you to use a tablet or a smartphone to remotely pre-configure the power and irrigation settings.

Refer to the P5XS application instructions [J62111] for more information.

| Only the Newtron® P5XS B.LED with Bluetooth option is compatible with remote configuration.

7.5 Setting the irrigation flow

The medical device must be set to minimum power to adjust the irrigation flow rate. Press the footswitch until a spray appears.

Because work habits, feedback and professional training differ from one professional to another, the user must ensure that the irrigation flow is compatible with the procedure to be carried out to prevent burns to the clinical site.

Adjust the irrigation flow using the irrigation flow configuration button. The flow rate must be adapted to the tip used and to the required treatment.

The configuration range goes from stopping the irrigation function at the minimum stop marked by "O" to activating

the purge function at the maximum stop marked by .

The irrigation flow configuration button can be removed to clean the medical device. The button cannot be sterilised. Each tip must be used in accordance with the settings defined in the ultrasonic generator irrigation and power settings table [J58000].

7.5.1 Activating the purge function/starting irrigation

The purge function is activated by pressing the footswitch or by moving the irrigation configuration button into the

 position.

The purge takes approximately 4 minutes and can be stopped by pressing the footswitch again.

7.6 Air inlets

Air inlets ensure correct ventilation of the control unit. Leave them uncovered to allow air to circulate.

7.7 Control pedal

The ON/OFF type control pedal is used by the practitioner to operate the medical device.

Pressing the footswitch automatically activates the handpiece ultrasounds, and the irrigation function if it is not deactivated.

The footswitch equipped with its cord cannot be disconnected. Its weight and antislip pad ensure good stability.

The light function remains active for approx. 9 seconds after the pedal is released.

7.8 Mains Connector

The mains connector with its earthing pin is used to connect the device to the electrical network via a disconnectable mains cord.

7.9 Switch

The mains switch is used to switch on (position I) or to stop (position O) the medical device.

7.10 Irrigation solution tank

The medical device is equipped with a tank designed to hold 300 ml or 500 ml of irrigation solution depending on the option chosen. The maximum capacity is shown by the MAX mark on the tank.

The irrigation solution tank is fitted with a plug. Neither the tank nor the plug can be sterilised.

7.11 Filling the tank

Remove the tank from the medical device by pulling it upwards. Fill the irrigation solution tank up to the MAX mark with an irrigation solution that is approved for the medical device.

The following solutions are approved for use with the device:

- Hydrogen peroxide < 3%
- Chlorexidine < 3%
- EDTA Ethylenediaminetetraacetic acid < 1%
- Sodium Hypochlorite < 0.9%
- Sterile water, distilled water, deionised water, demineralised water
- Saline solution at 0.9%



The following solutions must not be used:

- Hextril® Hexedrin
- Bleach

7.12 Cassette

The medical device is fitted with a peristaltic pump. This pump is subject to wear and must be replaced by the practitioner using the kit provided, or by the Acteon Customer Service team. Wear of the peristaltic pump depends on your use. However, it is advisable to replace the peristaltic pump at least once to twice per year.

Refer to the chapter *Replacing the irrigation cassette* page 24 for full instructions.

8 Disinfection and sterilising

The instructions relating to cleaning, disinfection and sterilisation protocols for accessories provided by SATELEC, a company of Acteon group have been approved for each medical device and accessory. The applicable guides are listed in the chapter *Associated documentation page 5*.

They can be downloaded at the following address: www.satelec.com/documents.

Download



Instructions For Use

In all cases, the local regulations in force relating to the cleaning, disinfection and sterilisation protocols for accessories take precedence over the information provided by SATELEC, a company of Acteon group.

8.1 Clean and disinfect the medical device

The medical device's control unit must be cleaned and disinfected daily.

The handpiece must be cleaned, disinfected and sterilised after each use.

- Do not immerse the handpiece.

The medical device must be in OFF or O stop position during cleaning and disinfecting procedures.

Refer to the instructions in the chapter *Cleaning the irrigation system page 23*.

Use alcohol disinfectant wipes.

Avoid using cleaning and disinfection products that contain flammable agents.

Otherwise, ensure that the product has completely evaporated or that there is no fuel left on the medical device and its accessories before switching it on.

- Do not use an abrasive product to clean the medical device.

- Never apply sprays directly to the medical device to clean it. Always spray the product onto a wipe, then clean the medical device.

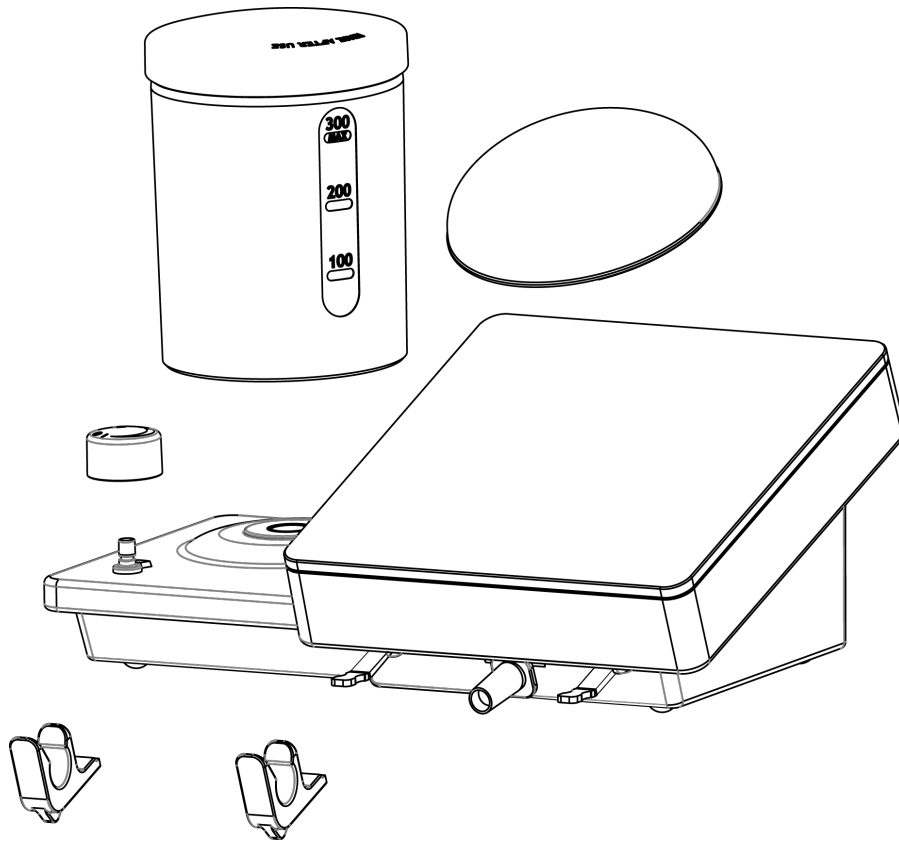

To prepare for cleaning, remove the various parts of the Newtron® P5XS B.LED as shown here.

8.2 Cleaning, disinfecting and sterilising accessories

Refer to the cleaning, disinfection and sterilisation instructions for accessories listed in the chapter *Associated documentation page 5*.

9 Monitoring and routine maintenance

The only preventive maintenance the medical device requires is:

- Monitoring of accessories
- Routine cleaning, disinfection and sterilisation
- Cleaning

Check the cleanliness of the air inlets on the control unit to prevent any heating.

Check the cleanliness of the handpiece nosepiece. It must be clean, smooth and corrosion-free. The handpiece must screw easily and firmly inside it.

Check the condition of the handpiece rear seals, which must not be distended, torn or broken.

Before and after use, check the medical device and its accessories entirely for any problems. This is necessary to detect any electrical isolation fault or damage. If necessary, replace damaged parts.

9.1 Cleaning the irrigation system

Operate the device at minimum power, at maximum irrigation flow rate for two minutes.

If your medical device has a tank:

1. Fill the tank with hypochlorite diluted at less than 3%.
2. Position the irrigation flow configuration button on purge.
3. Operate the irrigation spray for two minutes to rinse the medical device's internal water system.
4. Refill the tank with demineralised or distilled water, or even drinking water.
5. Rinse the system for two minutes.

When the irrigation system has been cleaned, perform the following operations:

1. Disconnect the handpiece and refer to the handpiece cleaning, disinfection and sterilisation instructions [J12911].
2. Clean and disinfect the medical device as indicated in the chapter *Clean and disinfect the medical device page 21*.
3. Follow the instructions for cleaning, disinfecting and sterilising SATELEC, a company of Acteon group accessories [J81001] and [J02001].

9.2 Corrective Maintenance

In the event of faulty operation, the following corrective maintenance actions may be performed by the user.

9.2.1 Replacing the fuses

The medical device is protected by two fuses in the mains connector.

To replace the fuses, perform the following operations:

1. Stop the medical device (position O).
2. Disconnect the mains cord from the electrical network.
3. Disconnect the mains cord from the mains connector.
4. Insert the tip of a flathead screwdriver into the notch on top of the fuse holder to release it.
5. Remove the used fuses.

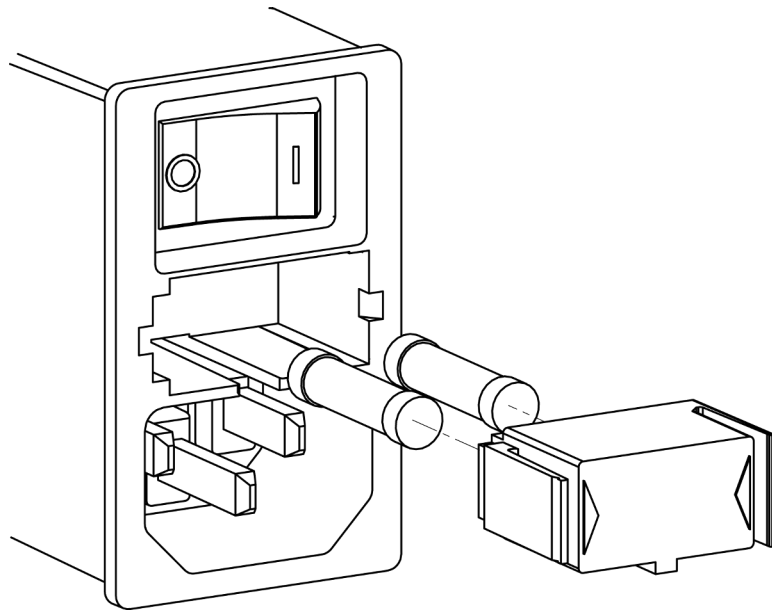

6. Replace the used fuses with fuses of the same type and same rating.
7. Place the fuse holder in its recess by pushing it until you hear a click that confirms it is in the correct position.
8. Connect the mains cord to the connector.
9. Connect the mains cord to the electrical network.

9.2.2 Replacing the irrigation cassette

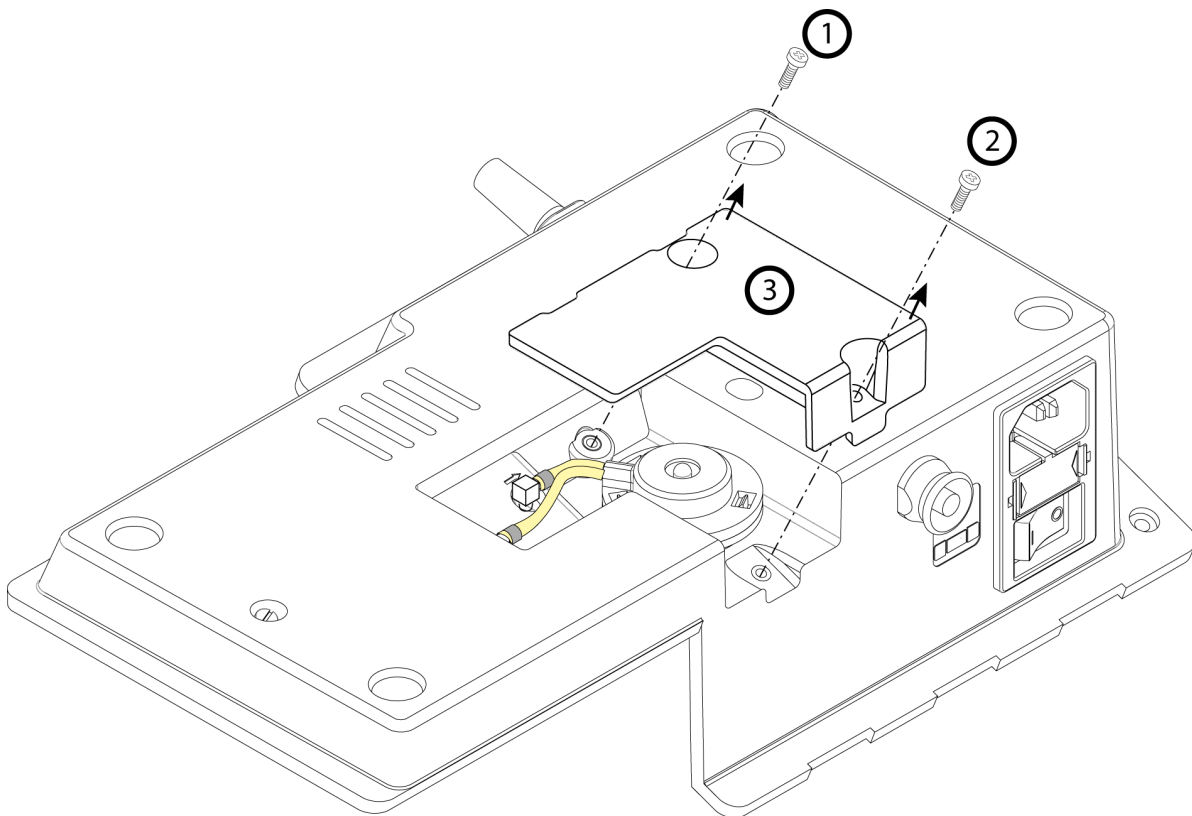

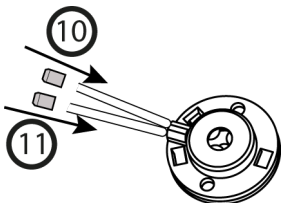
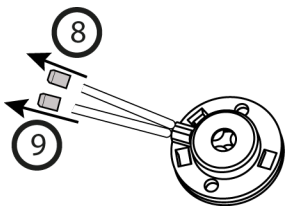
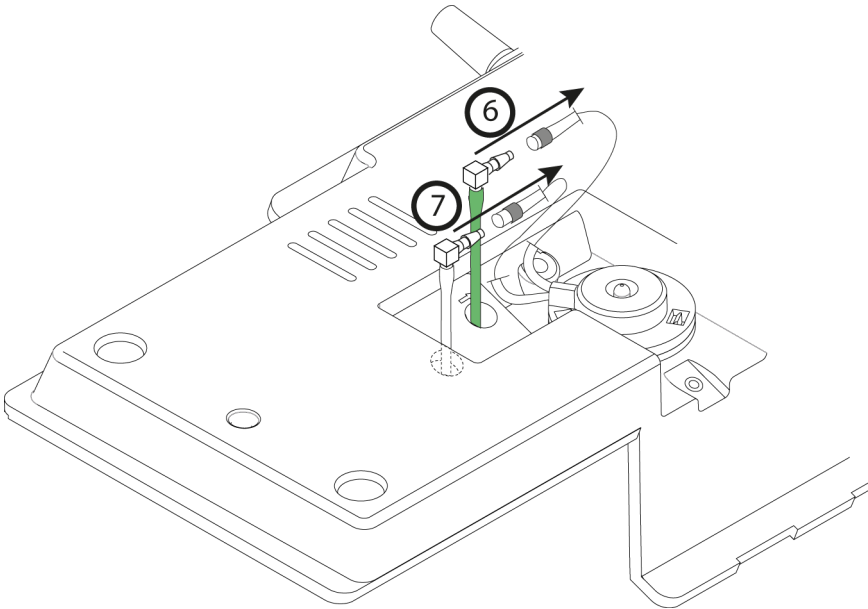
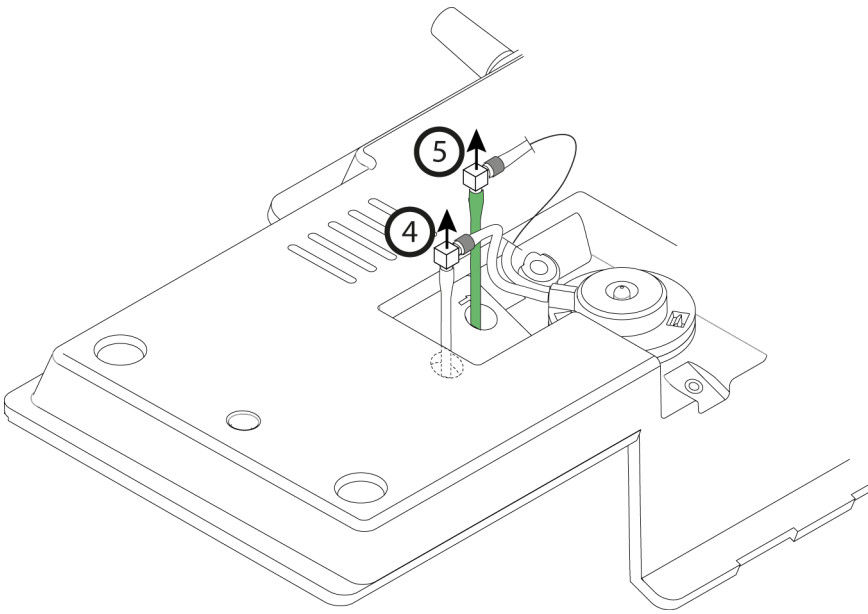

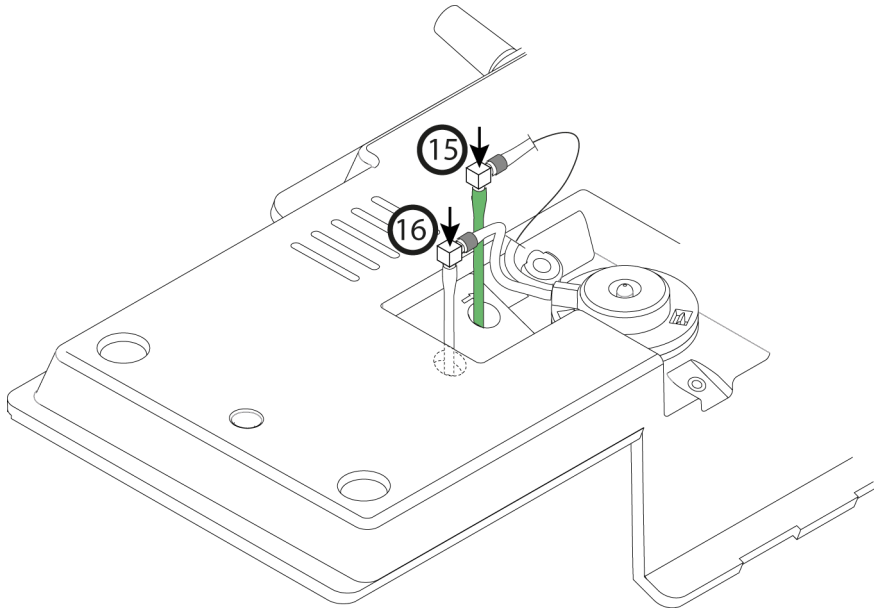
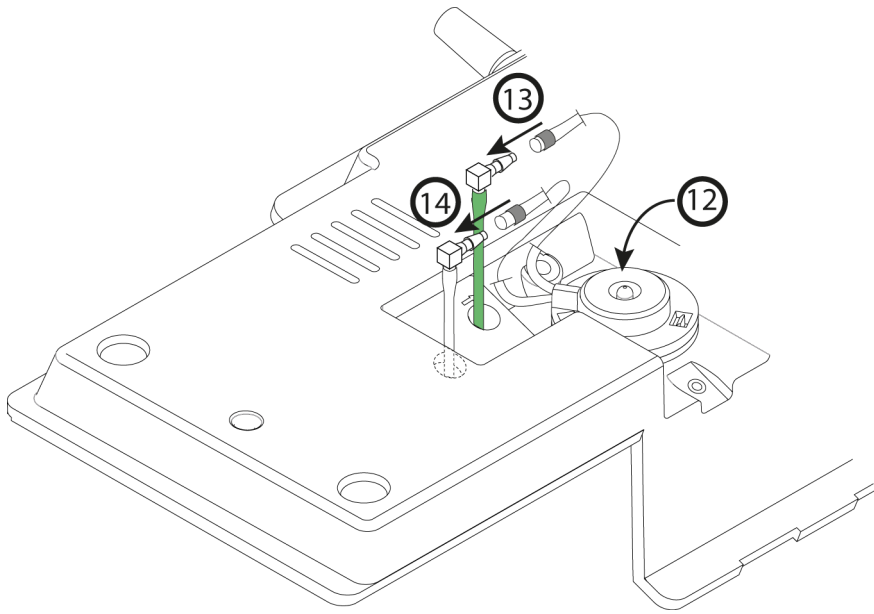

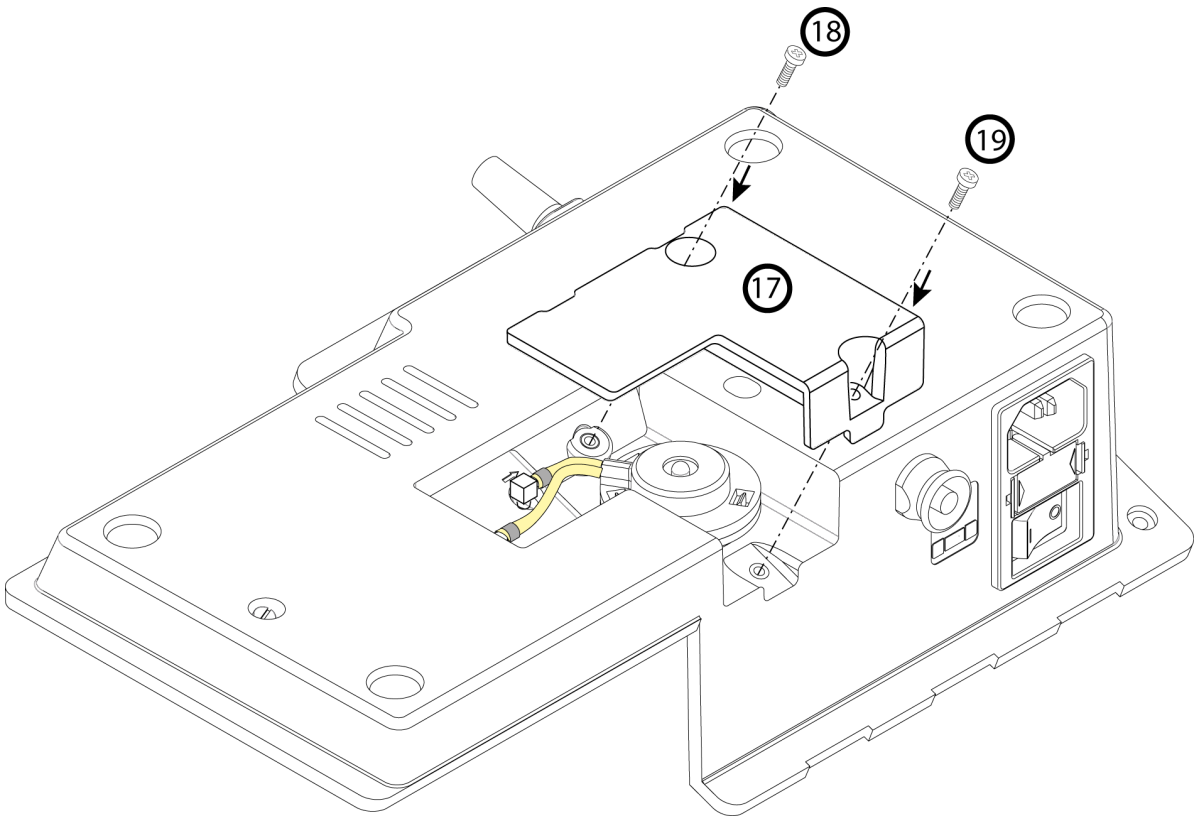

10 Identifying incorrect operation

In the event of incorrect operation, refer to the tables below to quickly identify and repair the non-complex parts of the medical device.

If the incorrect operation is not described in the tables below, please contact your supplier or the customer service team at SATELEC, a company of Acteon group.

Do not use the medical device if it appears to be damaged or faulty. Isolate the medical device and make sure that it cannot be used.

10.1 Not working

Symptoms: the light indicator on the medical device is off and the medical device is not working.

Possible causes	Solutions
No electrical current	Contact your electrician
Mains switch in position O	Set the mains switch to position I
Faulty connection between the mains cord and the electrical wall socket	Connect the mains cord to the electrical wall socket
Faulty connection between the mains cord and the mains connector	Connect the mains cord to the mains connector
Internal fuse not working	Return to the Acteon Customer Service team
Mains fuses in the mains connector not working	Replace the mains fuses with fuses of the same type and rating

| The internal fuse (ref. FU1 on the printed circuit board) cannot be accessed by the user.

10.2 No spray

Symptom: There is no water spray at the tip.

Possible causes	Solutions
Flow configuration button on minimum	Adjust the flow control button
Tip or file blocked	Unblock the tip or file using an ultrasonic tank
Incorrect choice of tip	Check the tip
Inadequate amount of spray	Adjust the spray
No irrigation solution in the tank	Fill the tank with irrigation solution
Worn irrigation cassette	Replace the irrigation cassette as detailed in the chapter <i>Replacing the irrigation cassette page 24</i>

10.3 The power is not as expected

Symptoms: the tip does not vibrate at the expected frequency, the treatment is not progressing as normal and is taking longer or is at a standstill.

Possible causes	Solutions
Worn or bent tip	Replace the tip
Incorrect use: incorrect approach angle or inadequate pressure on the tooth	Refer to the user instructions available at www.acteongroup.com
Presence of liquid or moisture between the handpiece and cord	Dry the electrical contacts
Faulty handpiece seal	Replace the handpiece seal using the purpose-provided kit.

10.4 Ultrasounds not working

Symptoms: the tip does not vibrate.

Possible causes	Solutions
Tip loose	Fasten the tip using the wrench Replace your torque wrench (once a year)
Faulty connector contact	Clean the cord contacts
Handpiece cord wire(s) cut	Return to the Acteon Customer Service team to replace the cord

10.5 Water leakage

Symptoms: water is leaking between the base of the handpiece and its cord.

Symptoms: Water is leaking from one of the following places:

- under the tank;
- under the medical device.

Possible causes	Solutions
Wear of 1.15 mm x 1 mm handpiece seal	Replace the seal using the purpose-designed kit.
Wear of the tank seal	Contact SATELEC, a company of Acteon group's Customer Service team to replace the tank seal.
Worn irrigation cassette	Replace the irrigation cassette using the purpose-designed kit as detailed in the chapter <i>Replacing the irrigation cassette page 24</i>

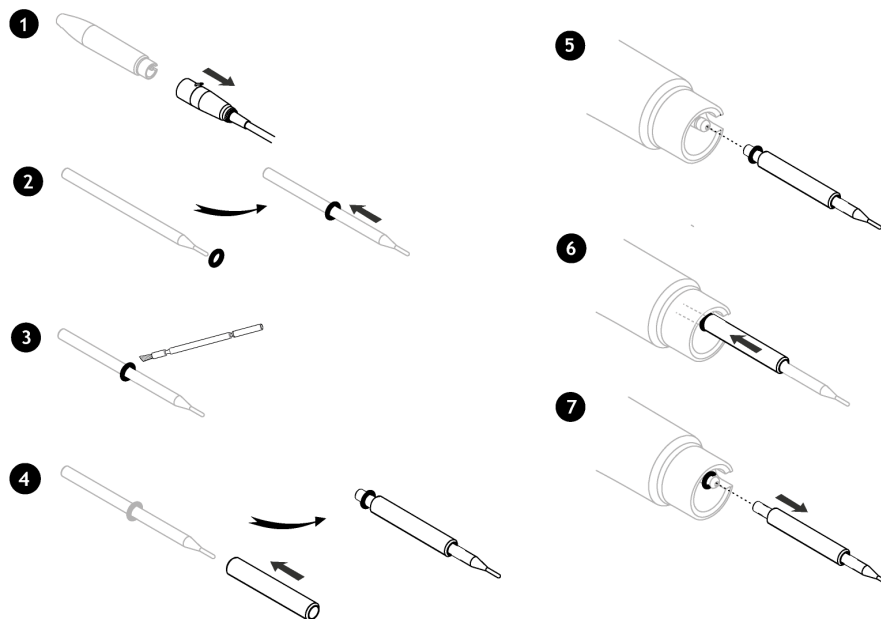

11 Technical specifications of the medical device

11.1 Identification

Manufacturer	SATELEC, a company of Acteon group
Name of the medical device	Newtron® P5XS B.LED Newtron® P5XS B.LED Bluetooth®

11.2 Generator

Supply voltage	100 - 240 VAC
Power supply frequency	50 - 60 Hz
Power consumption	60 60 VA
Voltage supplied to handpiece	150 VAC
Output frequency	Minimum 28 kHz
Power setting range	1 - 20
Type of leakage currents	LF
Operating mode	Intermittent: 10 minutes ON / 5 minutes OFF
Electrical rating	I
Internal fuse not accessible to the user	Ref : FU1 / T 1,5 AL 125 V - SMD - Interrupting capacity: 50 A
Fuse (mains connector)	2 fuses T 1 AL 250 VAC - 5 mm x 20 mm - Interrupting capacity: 35 A
Width	260 mm
Height	102 mm, 138 mm with 300 ml tank
Depth	185 mm
Weight	1800 g with pedal, handpiece cord and 300 ml tank
Ingress protection rating	IPX0

11.3 Length of cords

Handpiece cord	2 500 mm +/- 50 mm
Control pedal cord	2 500 mm +/- 50 mm

11.4 Irrigation

Tank capacity	300 ml or 500 ml
Nominal water output flow at the end of the handpiece	5 ml/min to 40 ml/min
Maximum water output flow at purge	80 ml/min

11.5 Footswitch

Width	72 mm
Height	30 mm
Depth	105 mm
Weight	220 g
Ingress protection rating	IPX1

11.6 Environmental characteristics

Ambient operating temperature	10 to +30°C
-------------------------------	-------------

Operating RH	30% to 75 %
Atmospheric operating pressure	Between 800 hPa and 1060 hPa
Maximum operating altitude	Equal to or less than 2000 metres
Storage temperature	0 to +50°C
Storage RH	10% to 100 %, including condensation
Atmospheric storage pressure	Between 500 hPa and 1060 hPa
Transportation temperature	0 to +50°C
Transportation RH	10% to 100 %, including condensation
Atmospheric transportation pressure	Between 500 hPa and 1060 hPa

11.7 Environmental restrictions

Usage premises	Usable in all medical premises. The medical device must not be used in an operating theatre or outdoors.
Use in gas-filled atmosphere	The medical device is not designed for use in a type AP or APG gas-filled atmosphere or in the presence of anaesthetic gases.
Immersion	The console must not be immersed.
Immersion	The handpiece must not be immersed.

11.8 Main performance characteristics

Ultrasonic vibrations of the tip or file fitted to the end of the conventional dental ultrasonic handpiece.

- Vibration frequency \geq 28 kHz.
- Tip amplitude \leq 200 μ m.

12 Regulations and standards

12.1 Applicable standards and regulations









This medical device complies with the essential requirements of European Directive 93/42/EEC. It was designed and manufactured in accordance with an EN ISO 13485-certified quality assurance system.

















This equipment is designed and developed in compliance with the Electrical Safety standard IEC60601-1 in force.









12.2 Medical class of the device

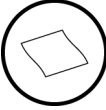
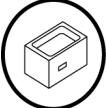

Class of medical device: IIa according to 93/42/EEC directive

12.3 Symbols

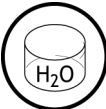
Symbol	Meaning
O	Switching off (OFF)
I	Switching on (ON)
 Protection Glasses Needed	Always wear safety goggles
	Always wear protective gloves
 Refer to Instruction Manual/Booklet	Refer to the supporting documentation
 Consult Instructions For Use	Consult the User Manual
 Electronic User Information	The accompanying documentation is available in electronic format
	Pressure limit
	Temperature limit
	Humidity limit

Symbol	Meaning
	Packaging unit
	Fragile, handle with care
	Store in a dry place
	Biohazard
	Sterilisation at 134°C in an autoclave
	Sterilisation at 132°C in an autoclave
	Washer-disinfector for thermal disinfection
	Type LF part in contact
	Alternating current
	Intensity
	Purge
	Peristaltic pump
	Electromagnetic interference
	CE marking
	CE marking
	Year of manufacture

Symbol	Meaning
	Manufacturer
 <p data-bbox="323 398 427 450">Do not dispose of as household waste</p>	Do not dispose of as household waste
	Recycle your lamps and professional electrical equipment with Récyllum
Rx Only	Under the United States Federal Law, this medical device must only be sold by or under the orders of a qualified doctor.
SN	Serial Number
PN	Packaging Number
	Use a dipping tank for cleaning
	Use a soft brush for cleaning
	Use a lint-free cloth for cleaning
	Use an ultrasonic tank for cleaning.
	Use a swab for cleaning
	Use deionised or osmosis-purified water for cleaning
	Use an alcohol disinfectant wipe for pre-disinfection and cleaning.
	Do not use the ultrasonic tank for cleaning.

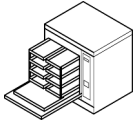
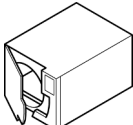
	Clean under running water
	Use a syringe for cleaning
	Use a washer-disinfector for cleaning and disinfection
	Use a pre-vacuum air autoclave for sterilisation

12.4 Manufacturer identification



SATELEC
 A Company of ACTEON Group
 17, avenue Gustave Eiffel
 BP 30216
 33708 MERIGNAC cedex
 France
 Tel. +33 (0) 556.34.06.07
 Fax. +33 (0) 556.34.92.92
 E.mail: satelec@acteongroup.com.
www.acteongroup.com



12.5 Branch addresses

U.S.A. & Canada

ACTEON North America
124 Gaither Drive, Suite 140
Mount Laurel, NJ 08054 - USA
Tel. +1 856 222 9988
Fax. +1 856 222 4726
info.us@acteongroup.com

GERMANY

ACTEON GERMANY GmbH
Industriestrasse 9 – 40822 METTMANN - GERMANY
Tel. +49 21 04 95 65 10
Fax. +49 21 04 95 65 11
info.de@acteongroup.com

SPAIN

ACTEON MEDICO-DENTAL IBERICA, S.A.U.
Avda Principal nº11 H
Poligono Industrial Can Clapers
08181 SENTMENAT (BARCELONA) - SPAIN
Tel. +34 93 715 45 20
Fax. +34 93 715 32 29
info.es@acteongroup.com

U.K.

ACTEON UK
Phoenix Park– Eaton Socon, St Neots
CAMBS PE19 8EP - UK
Tel. +44 1480 477 307
Fax. +44 1480 477 381
info.uk@acteongroup.com

MIDDLE EAST

ACTEON MIDDLE EAST
247 Wasfi Al Tal str.
401 AMMAN - JORDAN
Tel. +962 6 553 4401
Fax. +962 6 553 7833
info.me@acteongroup.com

CHINA

ACTEON CHINA
Office 401 - 12 Xinyuanxili Zhong Street -
Chaoyang District - BEIJING 100027 - CHINA
Tel. +86 10 646 570 11/2/3
Fax. +86 10 646 580 15
info.cn@acteongroup.com

THAILAND

ACTEON (THAILAND) LTD
23/45 Sorachai Building 16th floor - Sukumvit 63

Road, Klongton Nua - Wattana, BANGKOK 10110
- THAILAND
Tel. +66 2 714 3295
Fax. +66 2 714 3296
info.th@acteongroup.com

Hong Kong Re. Office

21/F, On Hing Building
Central - Hong Kong
Tel. +852 66 962 134
info.hk@acteongroup.com

INDIA

ACTEON INDIA
1202, PLOT NO. D-9
GOPAL HEIGHTS, NETAJI SUBASH PLACE
PITAMPURA, DELHI - 110034 - INDIA
Tel. +91 11 47 018 291 / 47 058 291 / 45 618 291
Fax. +91 79 2328 7480
info.in@acteongroup.com

LATIN AMERICA

ACTEON LATINA AMERICA
Bogotá - COLOMBIA
Mobile: +57 312 377 8209
info.latam@acteongroup.com

RUSSIA

ACTEON RUSSIA
Moscow, Gilyarovskogo str, 6b1
+7 495 1501323
info.ru@acteongroup.com

AUSTRALIA/NEW ZEALAND

ACTEON AUSTRALIA/NEW ZEALAND
Suite 119, 30-40 Harcourt Parade
Rosebery NSW 2018
Australia
Tel. +612 9669 2292
Fax. +612 9669 2204
info.au@acteongroup.com

TAIWAN

ACTEON TAIWAN
11F., No.1, Songzhi Rd.
Xinyi Dist., Taipei City 11047
TAIWAN (R.O.C.)
+ 886 2 8729 2103
info.tw@acteongroup.com

12.6 Disposal and recycling

As an item of Electrical and Electronic Equipment, the medical device must be disposed of via a specialist collection, removal, recycling or destruction channel. This applies in particular to the European market, in reference to Directive 2002/96/EC dated 27/01/2003.

When your medical device has reached the end of its service life, contact your nearest dental equipment dealer, or the Acteon head office or one of the company branches to find out how to proceed. The relevant contact details are given in the chapter *Branch addresses* page 37.



| The indication below applies to France only.

In compliance with the provisions of the French Environment Code relating to the disposal of electronic and electrical equipment waste or WEEE (Decree no. 2012-617 dated 2 May 2012), our Company fulfils its obligations to reclaim and dispose of its electrical and electronic equipment through the means established by the approved organisation Réylum, NOR approval: DEVP1427651A.

As a manufacturer, our Company is listed in the National Register of Producers kept by the ADEME (French Environment and Energy Management Agency). Professionals buying our products directly from the distribution chain are responsible for passing on this information about our established recycling methods to the end user.

In addition, the buyer agrees to take back our brand's devices at the end of their service life and to transfer them to one of the collection centres set up by Réylum for recycling (see list of collection centres on the site <http://www.recylum.com/>).

If necessary, Réylum can come and collect these devices from you free of charge once the quantity of devices has reached a certain level in the pallets-containers with which you are provided to store this waste.



An accessory that has reached the end of its service life must be disposed of in infectious clinical waste containers.

13 Index

3

300 ml 18

5

500 ml 18

A

altitude 32
Amplitude 32
approved dealers 7

B

B.LED 17
Bleach 19
Bluetooth 17
button removal 17

C

Chlorexidine 18
cleaned 15
cleaning and disinfecting the device 23
colour code 17
conservative and restorative dentistry 7
control pedal 13, 18
control unit 17

D

damage 23
deionised water 18
demineralised water 18, 23
dental file 7
disconnection devices 13
disinfected 15
disposal 38
distilled water 18
drinking water 23

E

earthing 18
EDTA Ethylenediaminetetraacetic acid 18
electrical safety 33
electronic 5
electronic user instructions 5
endodontics 7
European directive 33

F

fault 23
first inclusion of CE marking 8
Fuse 29
fuses 23

G

gas-filled atmosphere 32
general instructions relating to the complete range of ultrasonic dental generators 3

H

handpiece 5
Handpiece support 17
humidity 13
Hydrogen peroxide 18

I

incorrect operation 29
indexing points 13
inlets 18, 23
irrigation flow 18

L

light function 18
light indicator 17

M

mains connector 11, 18, 23
Mains power 11
Manufacturer 31

medical class 33

W

water leakage 30
wrench 5
wrenches 5

P

periodontics 7
peristaltic pump 19
pressure 32
procedure 17-18
prophylaxis 7
purge 17-18

Q

Quick Clean 3, 5
Quick Start 3, 5

R

recycling 38
Récyllum 38
repair 7
repairer 7

S

Saline solution 18
seal 30
silicone supports 17
slope of five degrees 13
smartphone 17
spray 18, 29
Sterile water 18
sterilised 15
switch 18, 29

T

tablet 17
tank 18
temperature 31
tip 5, 7, 29-30

U

ultrasonic vibrations 7
update 8
User Manual 3, 5

V

Vibration frequency 32



User Manual | Newtron® P5XS B.LED | J62151 | V6 | (13) | 09/2017 | NBADEN030F

SATELEC S.A.S. | A Company of ACTEON Group
17 av. Gustave Eiffel | BP 30216 | 33708 MERIGNAC cedex | FRANCE
Tel. +33 (0) 556 34 06 07 | Fax. +33 (0) 556 34 92 92
E-mail: satelec@acteongroup.com | www.acteongroup.com

