

FSH LOCKING

High Security Motorised Hook Lock

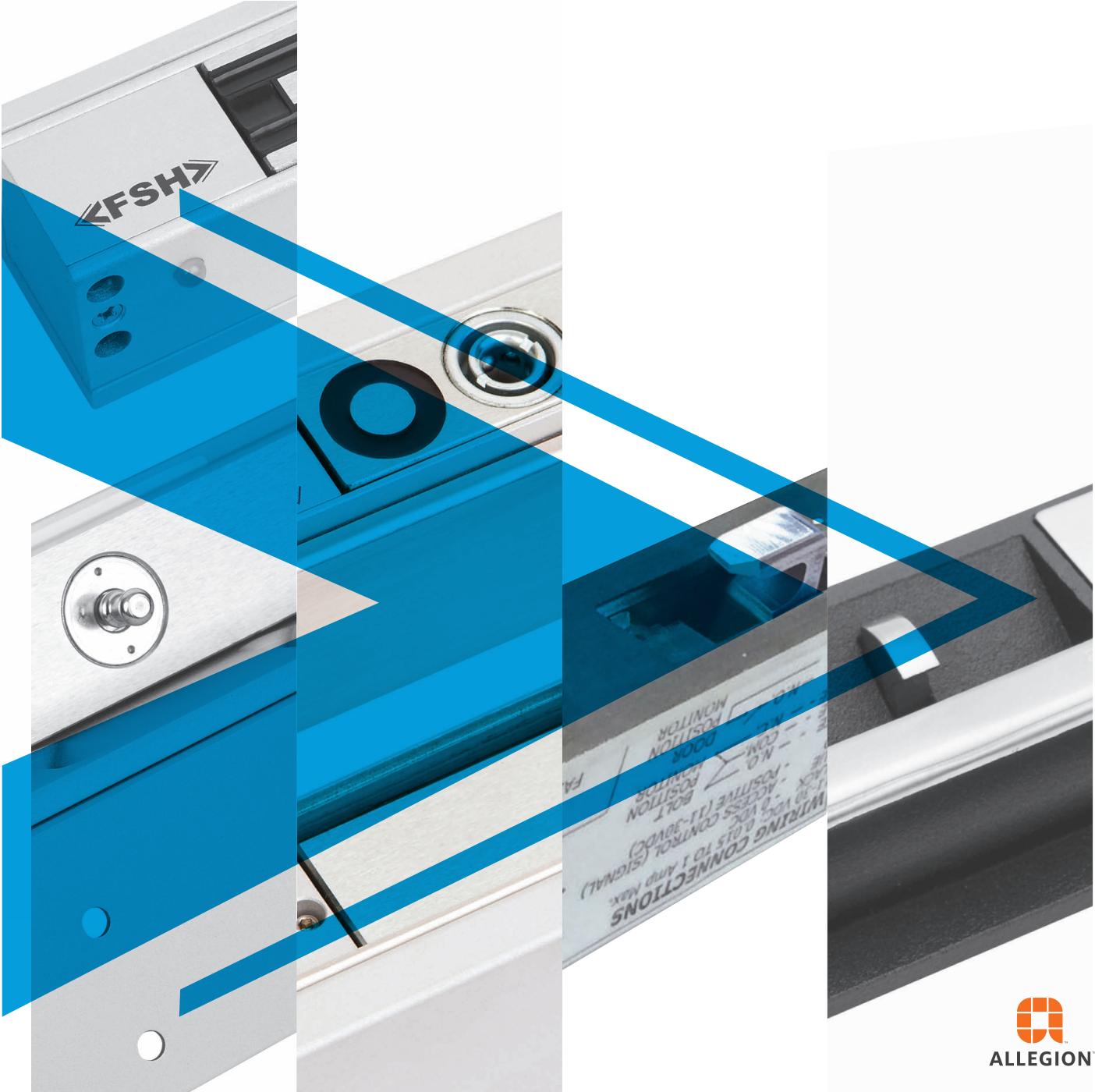

PRODUCT HL1260

HIGH SECURITY MOTORISED HOOK LOCK



HL1260

PRODUCT DESCRIPTION

The patented HL1260 is a high torque motor driven hook lock for a sliding door. It can be installed vertically in the door frame (lock style) with the strike plate mounted on the edge of the door.

Alternatively there is a surface mount box for the strike plate and/or lock for a sliding door.

The HL1260 can also be mounted with the surface mount box on the door header with the face plate on the face of a swing door.

The HL1260 is considered a "Green Product" as it consumes an in-rush current of 290mA@12VDC only during locking and unlocking action (active Mode), then in the locked or unlocked state (Sleep-Mode), the drop Bolt consumes current less than 15mA@12VDC.

TECHNICAL DETAILS

PART NO.	HL1260
FUNCTION	Mortise Mount, power-to-lock/power-to-release field interchangeable
HOLDING STRENGTH	Up to 1000kg
VOLTAGE/CURRENT	Multi Voltage 12-30VDC Active Mode: Locking/Unlocking cycle current is 0.29A to 0.85A depending on the load Sleep-Mode: After locking/unlocking the current drops down to ~0.015A (15mA)
APPROVALS	CE C-Tick
MONITORING	Lock Status Sensor of the internal locking mechanism Door Status Sensor Built-in Reed Switch, monitoring the door position
ENVIRONMENTAL	Operational Temperature Range -20 to +60C
DURABILITY	Exceeding Australian Standard AS4145.2-2008 400,000 operating cycles • Durability D7
STRENGTH	Meeting Australian Standard AS4145.2-2008 • Static Strength S8 • Impact Strength S8

PRODUCT FEATURES

- Motorised locking device
- Durability tested to 400,000 cycles
- Multi voltage from 12 to 30VDC
- Sleep-Mode Current less than 15mA@12VDC
- Fully monitored including Reed Switch for door position
- Up to 1000kg Holding Strength
- 5 year warranty

PRODUCT DIMENSIONS AND INSTALLATION

HL1260 Hook Lock Mortise Mount

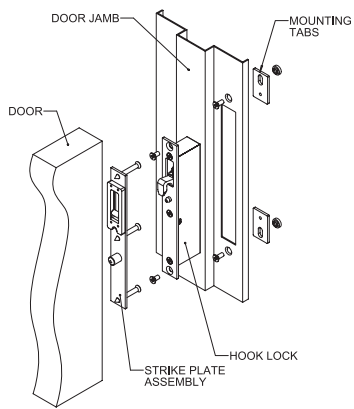

Strike Plate HL1260

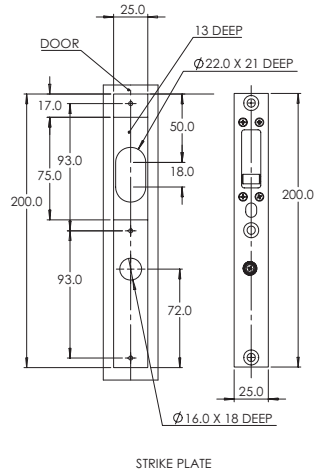

Locking Device HL1260

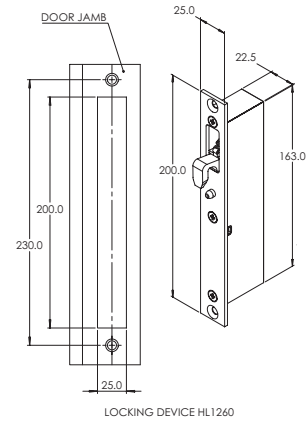

HL1260 Surface Mount Box

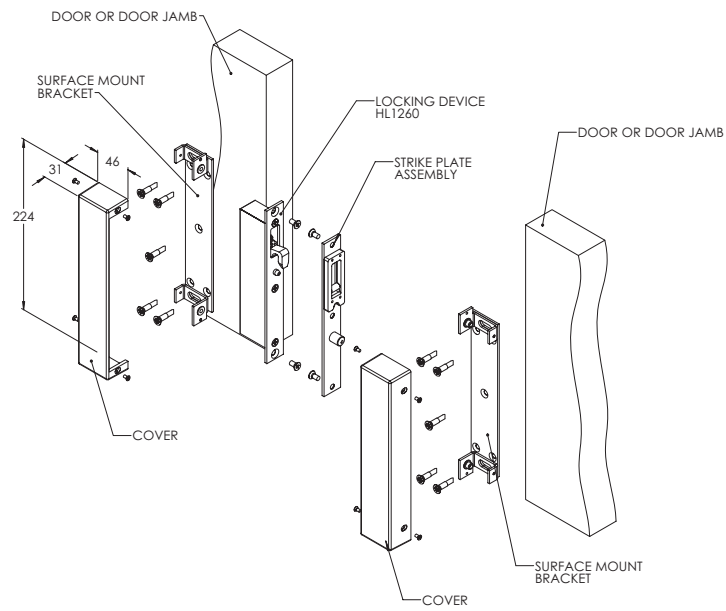



WALKING GENTLY
ON OUR PLANET



ALLEGION

FSH is an Allegion™ company

