

GUARD doorstation mkII

For secure remote access entry.



features:

- ▶ telephone-line powered
- ▶ hands free operation
- ▶ loud speaker output > 78dBa/1metre
- ▶ auto dialling with alternate numbers
- ▶ multi-number dialling option *up to 3 buttons*
- ▶ push-to-talk option *for noisy environments*
- ▶ remote level control *speaker/microphone*
- ▶ remote relay activation *door release*
- ▶ remote programming facilities
- ▶ remote diagnostic testing
- ▶ self identification
- ▶ vandal resistant
- ▶ weathershield panel/enclosure *stainless steel*
- ▶ 12Vdc booster amplifier - *optional*

versatile

easy to use

durable

dependable

The **Guard Doorstation** is a powerful all in one, interactive telephone unit that thinks for you. It offers security and control literally at your finger tips. Designed to fit any place you require a high quality, loud speaker, hands-free telephone. It is well suited for homes, hotels, hospitals and universities as well as many business and commercial settings. Guarding you against unwanted entry onto your property, this unit will give you the ability to authorise access to welcomed visitors without having to leave the comfort of your home or office. The **Guard**, *making sure your safety and well-being come first!*

easy to install:



Installation is made easy thanks to the line powered Guard, only a single pair of line wires are required for operation. The housing allows for trouble free mounting to just about any surface. Programming and setting up of the unit is flexible, either via a remote touch tone phone or using a local keypad (*if fitted*). Extremely simple instruction sets are used for quick setup.

easy to use:



The Guard is an interactive telephone, while on line the remote operator can control certain features of the Guard by ways of keypad tones. The Guard's microphone and speaker level can be adjusted remotely as well as individually activating up to two separate relays. Multiple call buttons can be fitted on request.



GUARD doorstation mkII

specifications:

PSTN:	exchange line or analog PABX extension	24 - 50 volts @ 18 - 100mA
DTMF:	tone duration inter-digit pause	80 milli-seconds 80 milli-seconds
DIALLING:	digit capacity direct number call alternate number call	16 3 (optional) 2
RELAY:	switching maximum	60Vdc / 40Vac SELV or TNV 2kV isolated voltage free contacts
SPL:	speaker output level	>78dBa @ 1 metre (onboard amplifier) 18 - 80mA >84dBa @ 1 metre (booster amplifier) ext. 12Vdc
PHYSICAL:	panel dimensions weight material button	225.0mm x 100.0mm 700 grams stainless steel 304 non rusting stainless steel, water resistant
REN:		0.7

~ This unit must be installed by qualified personnel ~

enclosure:

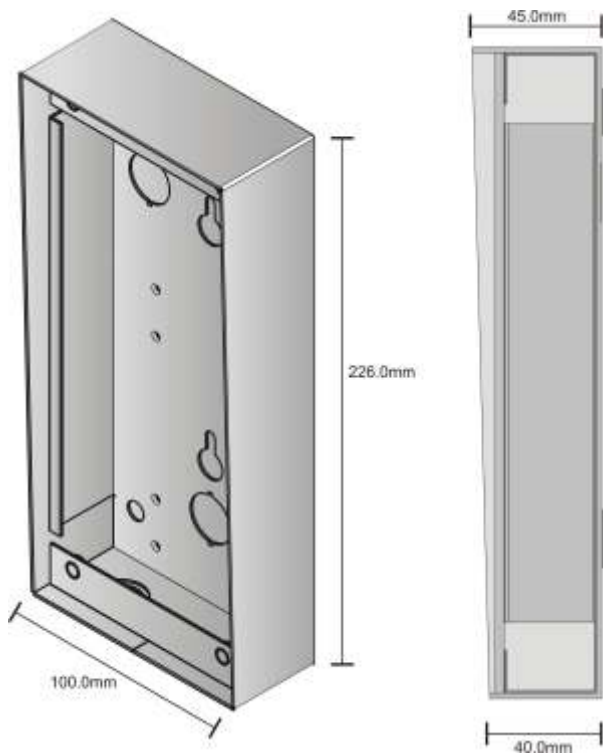

The Guard Doorstation mkII boasts a vandal resistant, robust stainless steel housing. This enclosure is slightly hooded at the top and offers weather-shielding for the toughest of environments. Mounting of your telephone can be easily made to just about any surface thanks to this versatile enclosure.

Dimensions:
226.0mm (height)
100.0mm (width)
45.0mm (depth)

The information contained on this product brochure is subject to change without notice.



complies with:
ACA
EN60950
AS/NZS3548
EN55022

All relevant Australian Communications Authority Standards
European Safety Standard
EMI Australia/NewZealand Standard
EMI European Standard (CISPR22)



designed and manufactured by:

dallas delta corporation *pty. ltd.*

102 albert st. east brunswick, victoria, australia 3057

tel: (613) 9387 7388 fax: (613) 9387 3128

email: sales@dallasdelta.com.au

ABN: 11005 617 532

www.dallasdelta.com.au

