

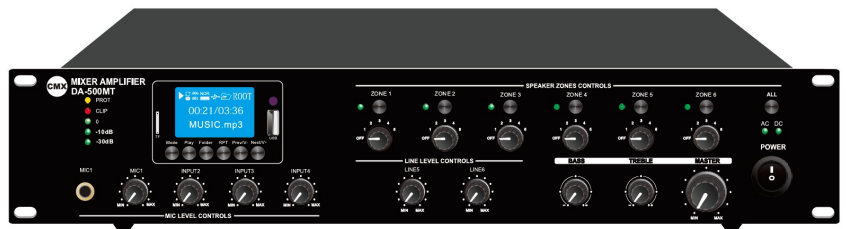

# INSTALLATION AND OPERATION MANUAL

## DA-60MT, DA-120MT, DA-240MT DA-350MT, DA-500MT, DA-500RM

6 Zone Mixer Amplifiers with Mp3/FM/BT



Caution: Please read this manual carefully before operating  
Damage caused by misuse is not covered by the warranty



# SAFTY WARNINGS!

1. Read and keep these instructions.
2. Heed all warnings and follow all instructions.
3. Do not use this apparatus near water.
4. Do not block any ventilation openings. Install in accordance with the manufacturer's instructions.
5. Do not install near any heat sources such as radiators, heat registers, stoves, or other apparatus that produce heat.
6. Do not defeat the safety purpose of the polarized or grounding-type plug. A polarized plug has two blades with one wider than the other. A grounding type plug has two blades and a third grounding prong. The wide blade or the third prong is provided for your safety. If the provided plug does not fit into your outlet, consult an electrician for replacement of the obsolete outlet.
7. Protect the power cord from being walked on or pinched particularly at plugs, convenience receptacles, and the point where they exit from the apparatus.
8. Only use attachments/accessories specified by the manufacturer.
9. Use only with the cart, stand, tripod, bracket, or table specified by the manufacturer, or sold with the apparatus. When a cart is used, use caution when moving the cart/apparatus combination to avoid injury from tip-over.
10. Unplug this apparatus during lightning storms or when unused for long periods of time.
11. Refer all servicing to qualified service personnel. Servicing is required when the apparatus has been damaged in any way, such as power-supply cord or plug is damaged, liquid has been spilled or objects have fallen into the apparatus, the apparatus has been exposed to rain or moisture, does not operate normally, or has been dropped.
12. This appliance shall not be exposed to dripping or splashing water and that no object filled with liquid such as vases shall be placed on the apparatus.
13. Plug this apparatus to the proper wall outlet and make the plug to be disconnected readily operable.
14. Main plug is used as disconnected device and it should remain readily operable during intended use. In order to disconnect the apparatus from the mains completely, the mains plug should be disconnected from the mains socket outlet completely.
15. **WARNING:** To reduce the risk of fire or electric shock, do not expose this apparatus to rain or moisture.
16. An appliance with a protective earth terminal should be connected to a mains outlet with a protective earth connection.

## WARNING!

TO PREVENT FIRE OR SHOCK HAZARD, DO NOT USE THE PLUG WITH AN EXTENSION CORD, RECEPTACLE OR OTHER OUTLET UNLESS THE BLADES CAN BE FULLY INSERTED TO PREVENT BLADE EXPOSURE.

TO REDUCE THE RISK OF FIRE OR ELECTRIC SHOCK, DO NOT EXPOSE THIS APPLIANCE TO RAIN OR MOISTURE.

TO PREVENT ELECTRICAL SHOCK, MATCH WIDE BLADE PLUG TO WIDE SLOT, FULLY INSERT.



The lightning flash with arrowhead symbol, within an equilateral triangle, is intended to alert the user to the presence of uninsulated "dangerous voltage" within the product's enclosure that may be of sufficient magnitude to constitute a risk of electric shock to persons.

### CAUTION

RISK OF ELECTRIC SHOCK  
DO NOT OPEN

**WARNING:** TO REDUCE THE RISK OF ELECTRIC SHOCK, DO NOT REMOVE COVER (OR BACK). NO USER SERVICEABLE PARTS INSIDE. REFER SERVICING TO QUALIFIED SERVICE PERSONNEL.



The exclamation point within an equilateral triangle is intended to alert the user to the presence of important operating and maintenance (servicing) instructions in the literature accompanying the appliance.

# INTRODUCTIONS

## Description

The 6 Zone Mixer Amplifier with MP3, FM tuner & blue tooth, its rated power output from 60W, 120W, 240W, 350W to 500W, it is ideal for school, super market, bank, hotel BGM and speech use. It is all in one solution with two sources, pre amplifier and mixer power amplifier into one 19" 2U height unit, which is economy but of high reliable performance.

It integrates 3 audio sources into a mixer amplifier, plus Mic1(6.3mm) and Mic/Line input 2-4 (XLR), two line inputs, one EMC input and one RS45 input for 6 zone remote paging microphone. Mic1 VOX with highest priority except EMC input. One USB and one SD slots on front provide easy access and operation for installer and end-user.

The amplifier is designed with complete protection of overload, short circuit and high temp to avoid any damage.

These amplifiers are suitable for applications in bank, mosque, school, hotel, restaurant, theme centers and shopping center.

## Features

- Public address (PA) 6 zone commercial mixer power amplifier.
- 19" rack mount amplifier of 2U height.
- Rated outputs of 60W, 120W, 240W, 350W to 500W.
- 6 zone speaker outputs of 100V.
- Single speaker zone output of 100V/70V/4-16 Ohm
- Six zone speaker outputs with independent volume control.
- Built-in MP3 player by USB & SD, FM tuner & blue tooth.
- Four microphone inputs, Mic1(6.3mm) and Mic/Line input 2-4 (XLR).
- Line 1-2 inputs on rear panel by RCA.
- EMC input on rear panel with highest priority by RCA.
- One amplifier capacity of 6 remote paging microphones DA-500RM up to 300 meters.
- Microphone1 of VOX features of highest input priority except EMC input.
- Volume control for Mic1-4 and line 1-2, bass & treble and zone volume control on front panel.
- AC and DC Power, protection, clip six zone status indicators and output level meters.
- Overload, short circuit and high temp protection.
- AC 230V and 24V DC operation system.

# FRONT PANEL

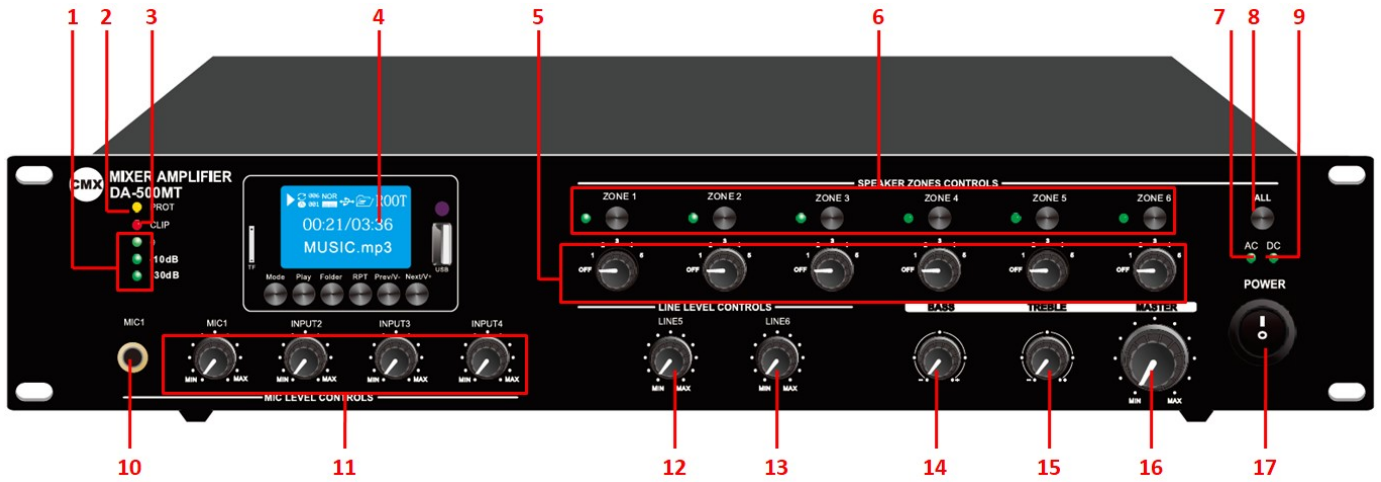

- |  |   |
|--|---|
| 1. Protection Indicator                      | 10. Mic1 Input with VOX priority except EMC Input |
| 2. Clip Indicator                            | 11. Mic1 and Input2-4 Attenuators                 |
| 3. Output Level Meters                       | 12. Line 5 Attenuator                             |
| 4. MP3 Module with FM & Blue Tooth           | 13. Line 6 Attenuator                             |
| 5. Speaker Zone1-6 Output Volume Attenuators | 14. Bass  |
| 6. Speaker Zone1-6 Selectors with Indicators | 15. Treble  |
| 7. AC Power Indicator                        | 16. Master Volume Control                         |
| 8. All Speaker Zone Selector                 | 17. AC Power Switch                               |
| 9. DC Power Indicator                        |   |

# REAR PANEL

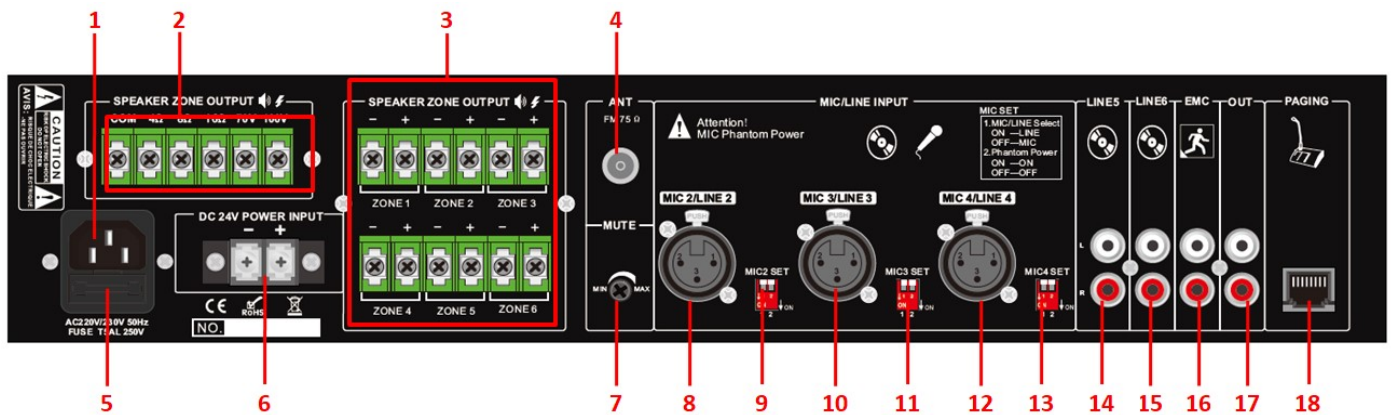

- |   |  |
|---|--|
| 1. AC Power Socket  | 10. Mic/Line 3 Input   |
| 2. Single speaker zone output of 100V/70V/4-16 Ohm          | 11. Input 3 Mic/Line Selector (Mic 3 with 48V phantom power) |
| 3. Speaker Zone 1-6 Outputs of 100 volt                     | 12. Mic/Line 4 Input   |
| 4. FM Antenna   | 13. Input 4 Mic/Line Selector (Mic 4 with 48V phantom power) |
| 5. AC Fuse  | 14. Line 5 Input   |
| 6. 24V DC Power Supply                                      | 15. Line 6 Input   |
| 7. MIC1 VOX Mute Attenuator                                 | 16. EMC Input from Fire Alarm System with Highest Priority   |
| 8. Mic/Line 2 Input   | 17. Line Output to External Amplifier                        |
| 9. Input 2 Mic/Line Selector (Mic 2 with 48V phantom power) | 18. RJ45 Input for Remote Zone Paging Microphone             |



**Male XLR-3P:**  
 Pin1-Ground  
 Pin2-Positive signal  
 Pin3- Negative signal

# REMOTE PAGING MICROPHONE DA-500RM



## DESCRIPTION

DA-500RM is a remote paging microphone work with DA-\*MT series amplifier, which is of 6 zone paging features, its communication distance up to 300 meters through straight CAT6 cable, each amplifier capacity of connection up to 6 units of remote paging microphone, these microphone are connected hand-by-hand. These 6 remote paging microphones could be pre-set different priorities by its dipswitch. The remote paging microphone is direct power supplied by the amplifier.

## DA-500RM FRONT PANEL & REAR PANEL

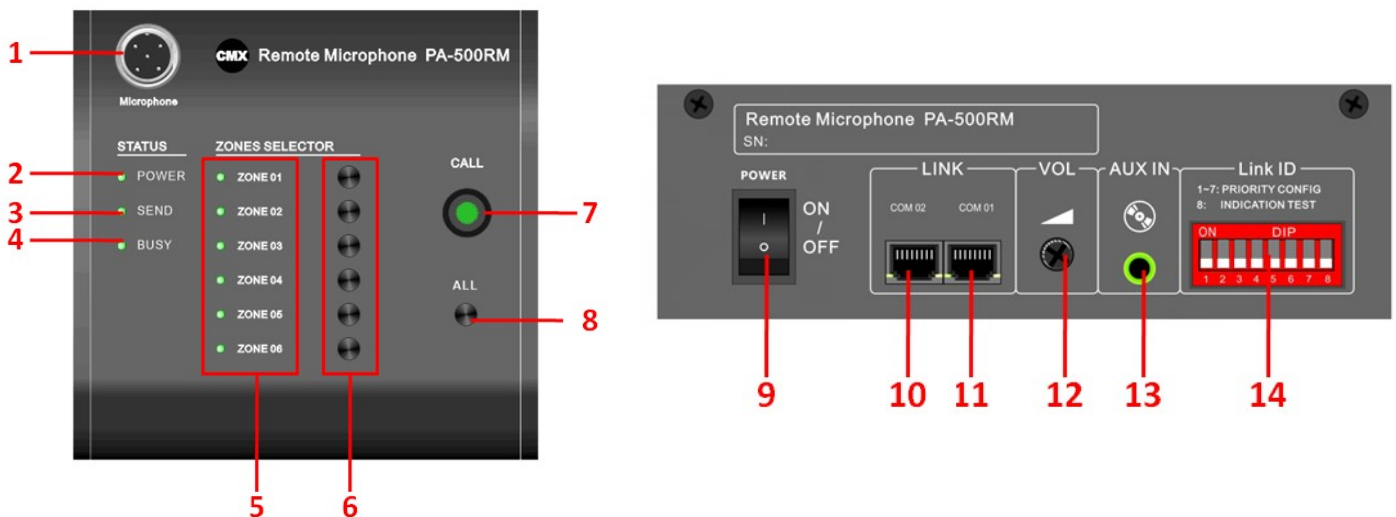

- |  |   |
|--|---|
| <ol style="list-style-type: none"> <li>1. Gooseneck microphone connector.</li> <li>2. Power indicator.</li> <li>3. Send or working indicator.</li> <li>4. Busy indicator.</li> <li>5. Speaker Zone 1-6 indicators.</li> <li>6. Speaker Zone 1-6 selectors.</li> <li>7. Call or talk button.</li> </ol> | <ol style="list-style-type: none"> <li>8. All speaker zone 1-6 selector.</li> <li>9. Power switch.</li> <li>10. RJ45 port to cascade another remote paging microphone.</li> <li>11. RJ45 port to communicate with DA-*MT series amplifier.</li> <li>12. Microphone volume control.</li> <li>13. Aux input.</li> <li>14. Priority &amp; Mic ID dipswitch.</li> </ol> |
|--|---|

# AMPLIFIER OPERATION GUIDANCE

## 100V Line System

For 100V line systems, connect the amplifier to the first speaker in the system using double-insulated speaker wire which has adequate current rating to handle the total output of the amplifier.

Connect the "100V" output terminal to the positive (+) connection of the speaker and "COM" output to the negative (-) connection of the speaker. Connect further speakers in parallel to the first speaker with all positive terminals and connected together and all negative terminals connected together as shown below.

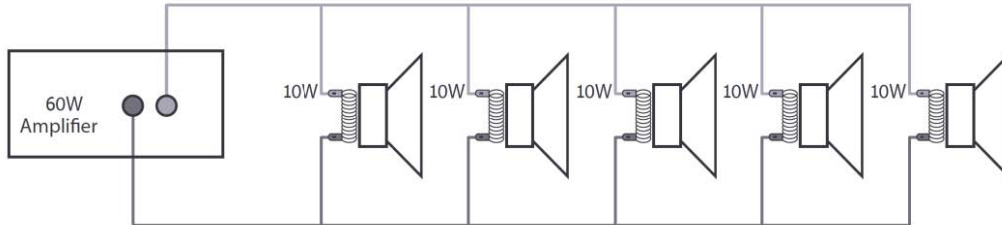

A 100V line speaker system can comprise of many speakers connected together. The determining factor for how many speakers can be used on a single amplifier is the power rating. For most purposes, it is advised to connect as many speakers as needed with a combined wattage of no more than 90% of the amplifier's output power rating.

The terminals of a 100V speaker are connected to a transformer and in some cases, this transformer may be "tapped" for different power ratings. These tapings can be used to adjust the wattage (and output volume) of each speaker in the system to help achieve the ideal total power of the system for the amplifier.

The mixer amplifier is featured of 6 speaker zone outputs, either one of six zone or total six zone power loading shall be equivalent or no higher than the rated power of the amplifier.

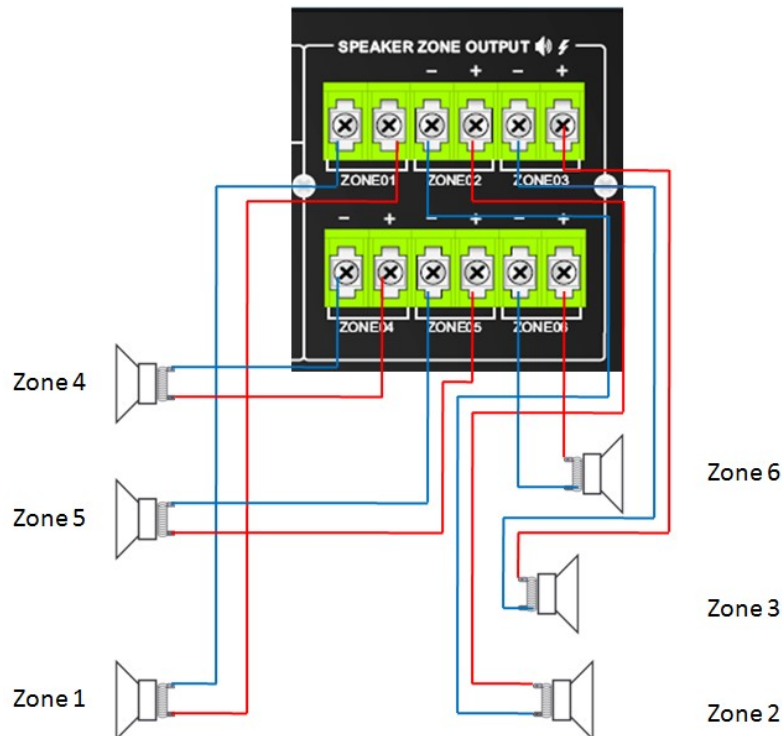

# OPERATION STEP

- When all connections to the amplifier are made, turn all rotary controls down and switch on the power and a power “ON” LED will illuminate. Turn BASS and TREBLE controls to the 12 o'clock position (pointing straight up) and turn MASTER rotary control up part way for testing.
- Ensure a signal is being fed to one of the line inputs 1, 2, 3, 4, 5, 6 or 7 and gradually increase the volume control for that channel until the output is heard through the speakers. Turn up the MASTER to the maximum required volume level and reduce the channel volume control if necessary.
- Note: The initial test can be made using the built-in USB/SD/FM audio player. The output of the amplifier is represented on the level meter LEDs and care should be taken that the Red “0” LED is only lit momentarily during use. Anything longer than a short flash of this LED may be indicating distortion or clipping of the output signal and the MASTER should be turned down.
- If a microphone is connected to MIC2-4 input, make sure it is switched on and if it requires phantom power, make sure this feature is enabled. Gradually increase its volume control whilst speaking into the microphone until the required volume level is reached. The microphone should not be able to “hear” the speakers, which can cause feedback (squealing or howling noise).
- If the VOX feature is enabled, audio playback through channels 2-6 will be reduced in volume automatically when speaking into MIC 1, use its attenuator to increase or decrease the mute level.
- In addition to channel and MASTER volume controls, there are BASS and TREBLE EQ controls to adjust the tone of the overall output. At the 12 o'clock position, these controls are applying no effect to the signal (no boost or cut). Moving the BASS control clockwise boosts the low frequencies in the audio, whilst moving it anticlockwise will cut these low frequencies. Likewise, moving the TREBLE control clockwise boosts the high frequencies in the audio, whilst moving it anticlockwise will cut these high frequencies. Adjust these EQ controls to suit the type of audio signal or compensate for the room acoustics.

## Media Player



1. TF card input
2. LED display
3. IR sensor
4. USB input
5. Mode to select MP3/BL/FM
6. Play
7. Folder
8. RPT repeat
9. Previous & volume- decrease
10. Next & volume + increase

The mixer-amplifiers are built-in a built-in media player which includes Mp3/FM/Bluetooth. Pressing the Mode button to switch the media player among Mp3/FM/Bluetooth according to the LED display, where there is one IR remote control enable to operate the media player remotely around 10 to 30 meters, this media player output volume control also could be controlled by the “TEL” volume knob.

## Bluetooth

The Bluetooth function allows connection of a smart phone or tablet to the media player section for playback of stored files or streamed digital audio. In order to enable this function, it will be necessary to pair the sending device to the receiver as follows.

1. Open the Bluetooth settings menu on the smart phone or tablet (or other sending device)

2. Scan for Bluetooth devices and look for it in the list of available devices (ensure that the amplifier is powered on and within 30-50 meters reception range)
3. Select the blue tooth and the sending device should confirm that it is connected as an audio device
4. Play audio from the sending device, ensuring that volume controls are not turned down/muted
5. Turn up the MEDIA volume control on the amplifier to the required level

If the Bluetooth signal is lost, it may be necessary to re-select the Bluetooth on the sending device.

The Previous, Next and Play/pause buttons will operate in Bluetooth as remote playback controls. Holding the Previous track or Next track buttons will adjust the output volume of the player.

## **USB/SD Playback**

Push a USB pen drive into the USB port and/or an SD card into the SD card input.

Press the CD/USB/SD button to ensure that the player is set to play from the required memory device. Press the PLAY/PAUSE button to play the current track and press again to pause as needed.

Searching and playback of tracks is the same as described above for the CD player

## **FM Tuner**

Press the FM select button to switch to the FM tuner function. Use the Previous or Next buttons to select a stored channel.

## **Tuning and storing stations**

Use the Forward/Reverse seek buttons to manually tune the frequency in steps of 0.05MHz

Alternatively, press and hold the Forward/Reverse seek buttons to auto search for available stations.

Upon finding a station, the auto search will stop, giving the option to store this station.

At this point, pressing the PLAY/PAUSE button will flash a "00" channel number in the display.

Use the Previous/Next buttons to select an appropriate channel memory.

Press PLAY/PAUSE again to confirm and store the station into the selected channel memory.

Auto search can be stopped at any time by pressing the Forward/Reverse seek buttons.



# CONNECTION DIAGRAMS

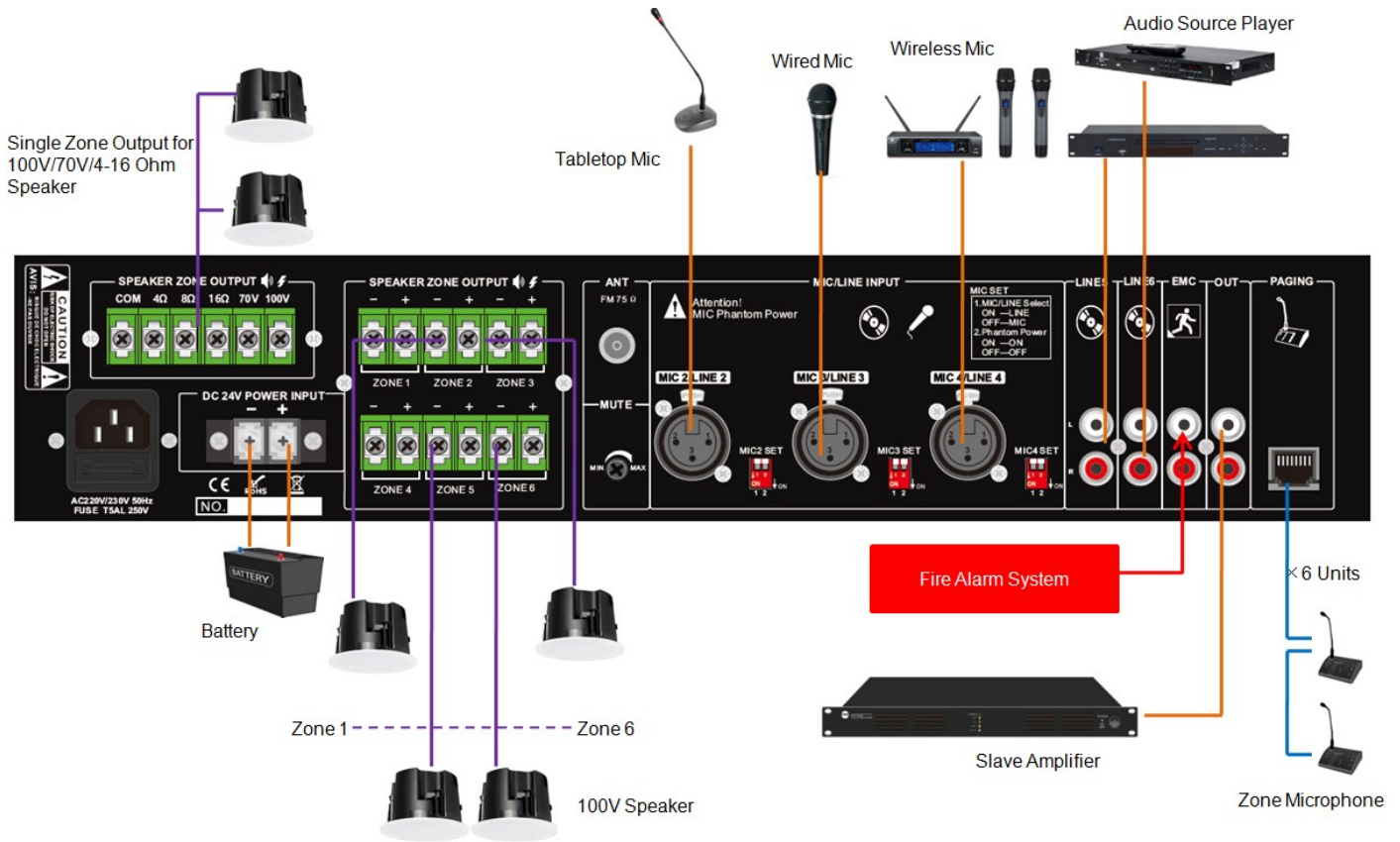

# SCHEMATIC DIAGRAMS

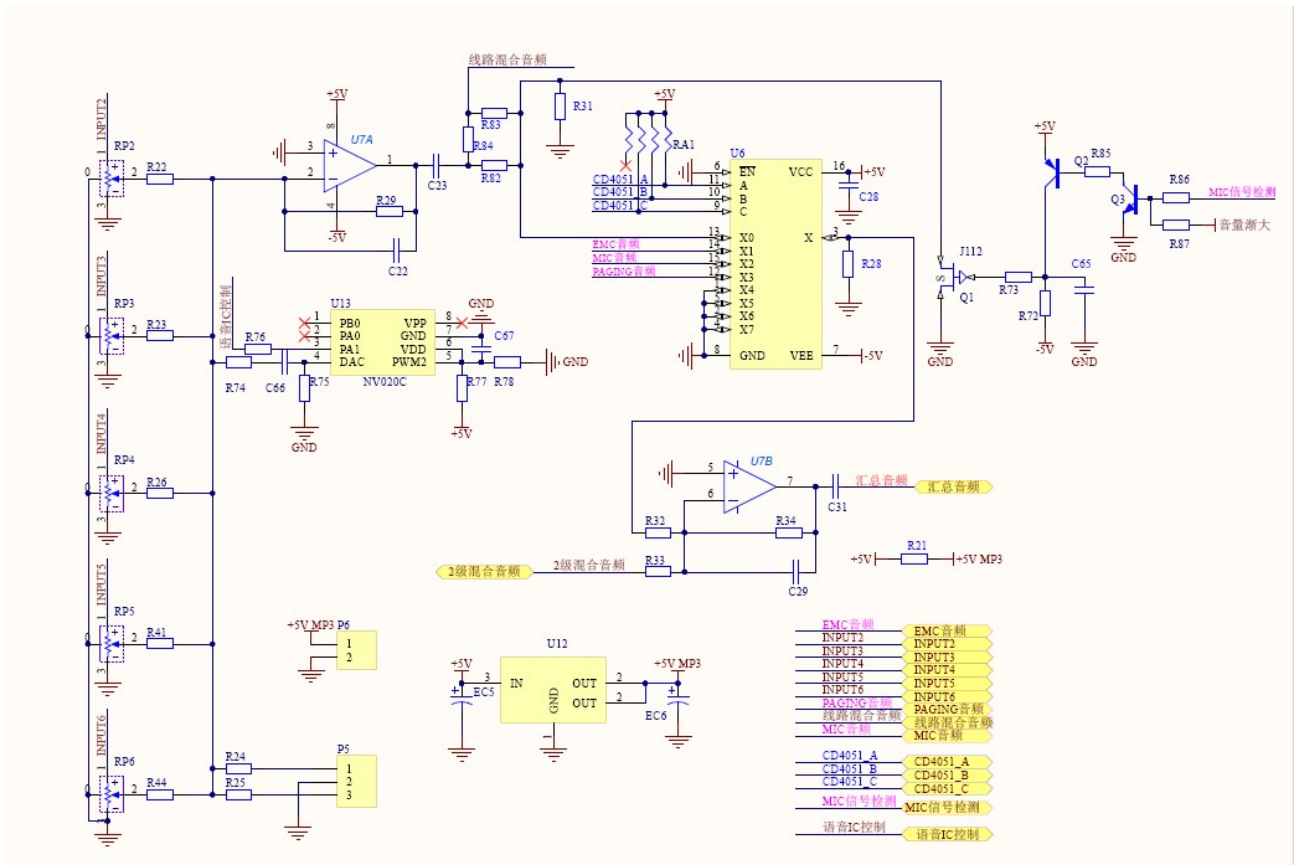

# SPECIFICATION SHEET

Model	DA-60MT	DA-120MT	DA-240MT	DA-350MT	DA-500MT
Description	6 Zone Mixer Amplifiers with Mp3/FM/BT				
Rated Power Output	60W	120W	240W	350W	500W
Speaker Output	100V of 6 Zones & Single Zone of 100V/70V/4-16 Ohm				
Input	Mic1-4: 2.5mV, Line1-2: 250mV; EMC: 250mV				
Frequency Response	80-16KHz				
THD	<0.1%				
S/N Ratio	>70dB				
Protection	High temp, short circuit, clip & overload protection				
Power Supply	AC230V or AC110V, 50-60Hz				
Power Consumption	100W	200W	400W	500W	650W
Dimension	438(W)×405(D)×88(H)mm				
Weight	8.2Kg	9.4kg	10.5kg	10.9kg	11.5kg
Warranty	5 years				

## SERVICE

Ensure the problem is not related to operator error, or system devices that are external to this unit. Information provided in the troubleshooting portion of this manual may help with this process. Once it is certain that the problem is related to the product contact your warranty provider as described in the warranty section of this manual.

## WARRANTY

Warranty terms of global three years. While the term and warranty may vary by country and may not be the same for all products. Terms and conditions of warranty for a given product may be determined first by locating the appropriate country which the product was purchased in, then by locating the product type.

**Guangzhou CMX Audio Co., Limited**

302RM 3#, Honghui Industrial Zone, Zhongyuan RD, Shibi Area, Panyu, Guangzhou, China 511497

Web: [www.cmxaudio.com](http://www.cmxaudio.com) E-mail: [info@cmxaudio.com](mailto:info@cmxaudio.com) Tel: +0086-20-39125019

**Specifications may change without pre-notice.**