

CM705B - Universal Expander Module CM707B - Plug On Zone Expander

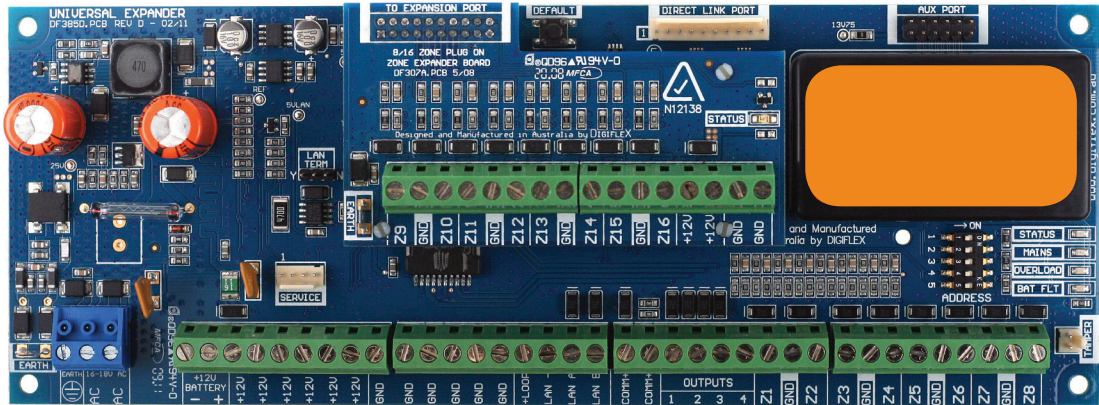

Security Systems

EN

Installer Reference Guide
Security System

BOSCH

CM705B - UNIVERSAL EXPANDER MODULE

The CM705B universal expander provides a cost effective way to increase the control panels zone inputs, programmable outputs and power supply capacity using a single expander module. This module is extremely useful when the system is comprised of multiple areas, as an expander can be located in each area providing power, siren and strobe outputs and up to 16 zone inputs.

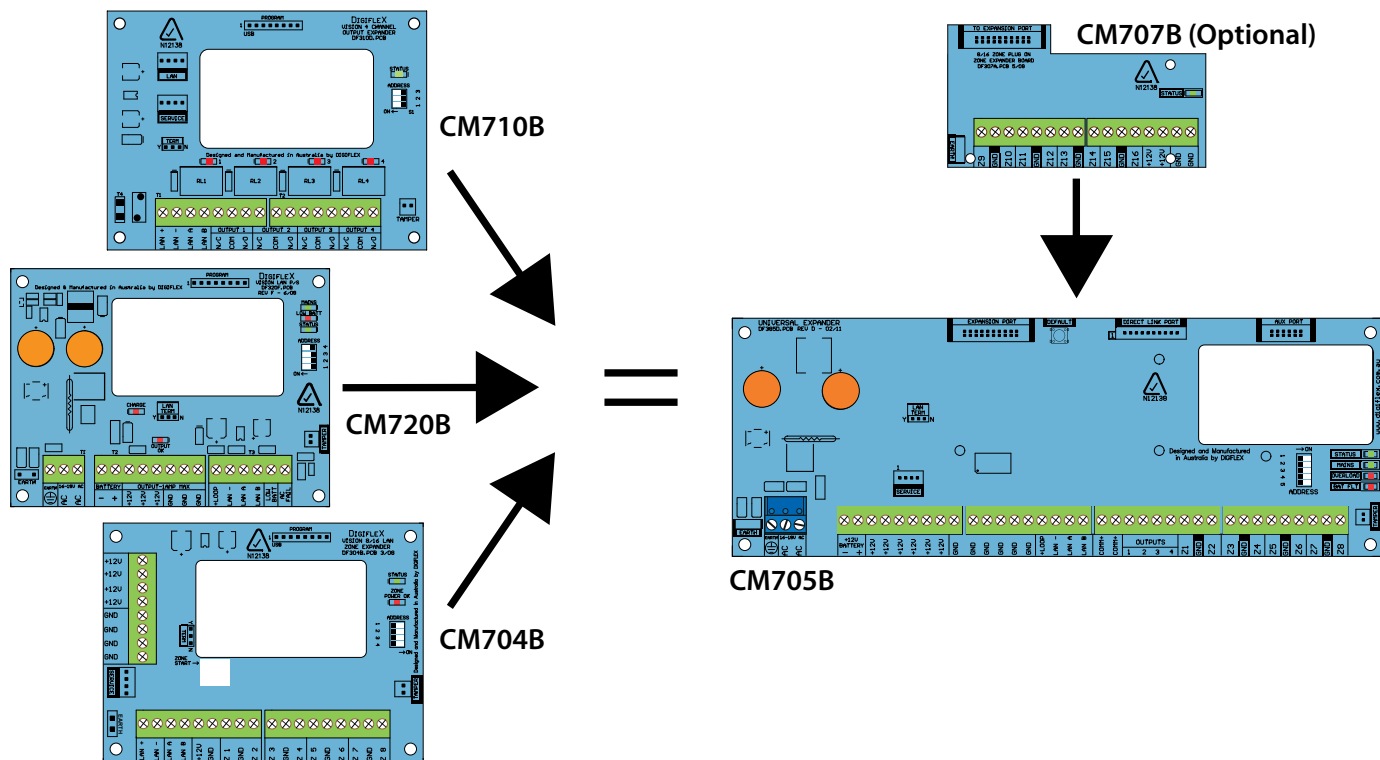

Figure 1: CM705B Comparison With Discrete Modules

The universal expander is available in a metal cabinet (CM705B) or as a PCB module only (CM705BP) depending on your requirements. The module connects to the control panel via the 4-wire encrypted RS485 LAN, and must be assigned a unique address on the LAN via the address DIP switch. See "Module Addressing" on page 3 for more details.

Dedicated service keypad and tamper inputs are provided. If the tamper input is not required, then you should disable it by fitting the supplied shunt to the tamper input.

Programming Considerations

The universal expander does not need to be enabled via panel programming. The control panel will recognise the module after a system power cycle or you can use the LAN scan command to force the system to scan for new modules connected to the LAN network without powering down the system. The LAN must be in the unsecured state or the system will not find new modules.

The EOL resistor value programmed in the control panel is common for all hard wired zones connected to the panel and each universal expander.

Zones on the universal expander must be programmed with a valid zone type before they become available for use. At factory default, zone inputs 17 and higher are set as 'Not Used'.

Outputs on the universal expander must be programmed as a valid output type before they become available. At factory default, outputs 9 and higher are set as 'Not Used'.

Refer to the control panel installation manual for specific zone and output programming information.

LED Indicators

The universal expander includes four LED indicators that provide feedback and trouble shooting information at the module. Various information is also provided at the system keypad via the device status menu.

LED Indicators		
LED	Status	Description
STATUS	Off	Module has no power (backup battery or A.C. mains power supply)
	Flashing	Indicates that communication between the control panel and universal expander is OK.
MAINS	On	Indicates that the A.C. mains voltage is connected.
	Flashing	Indicates that the A.C. mains voltage is not connected.
OVERLOAD	Off	Normal - no overload condition present.
	Flashing	There is an overload condition present on either COMM+ / +12v or one of the output terminals. See device status for more details.
BAT FLT	Off	Indicates that the backup battery is connected and charged.
	Flashing	Indicates that the backup battery has low voltage or is missing/dead.

Table 1: LED Indicator Descriptions

Module Addressing

A five way dip switch is used to set the universal expander address on the system (currently switch 5 is not used). The module's address setting determines which zone and output numbers will be available.

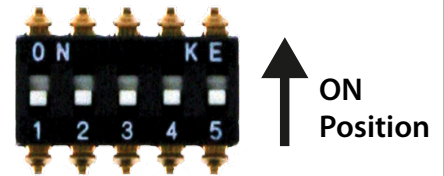

The universal expander is like having 1 x CM704B zone expander, 1 x CM710B output expander and 1 x CM720B power supply module all in one and as such each universal expander added to the system will consume the corresponding single function modules address. For example if the universal expander is assigned to address 4, then you cannot assign a CM704B, CM710B or CM720B module to address 4.



When Single EOL or Alarm + Tamper EOL options have been configured the first 8 zones are available on the control panel zone terminals. If Split EOL monitoring is selected the first 16 zones are available on the control panel zone terminals.

On panels with zone capacity greater than 16, each CM705B universal expander module on the system will occupy 16 zones regardless of the EOL resistor option selected. This means that when configured in Single EOL or in Alarm + Tamper mode each CM705B expander will provide 8 physical zone inputs only with an additional 8 zones which do not have any physical inputs. These spare zones can be assigned as RF zones, or you can install the optional CM707B plug on zone expander which provides an additional 8 hard wired zone inputs.

When Split EOL monitoring is selected each CM705B expander will provide 16 physical zone inputs and no spare inputs are available.

Single EOL Monitoring

If single EOL resistor option has been selected and one CM705B universal expander has been installed at address 1, the system will provide zones 1 to 8 on the main panel and then zones 17 to 24 on the expander module.

In this configuration there is no physical input for zones 9 to 16 or zones 25 to 32 however these spare zones could be assigned as RF zones if an RF receiver has been installed.

Split EOL Monitoring

If the Split EOL resistor option has been selected and one CM705B universal expander has been installed at address 1, the system will provide zones 1 to 16 on the main panel and zones 17 to 32 on the expander module. In this configuration each zone has a physical input available and there are no spare zones available.

Alarm + Tamper Monitoring

If the Alarm + Tamper monitoring EOL resistor option has been selected and one CM705B universal expander has been installed at address 1, the system will provide zones 1 to 8 on the main panel and then zones 17 to 24 on the expander module.

In this configuration there is no physical input for zones 9 to 16 or zones 25 to 32 however these spare zones could be assigned as RF zones if an RF receiver has been installed or you can install the optional CM707B plug on zone expander which provides an additional 8 hard wired zone inputs.

RF Zones

If an RF receiver has been installed, then all zones up to the maximum number supported by the panel become available for use.

Each RF zone can be assigned or mapped to either a physical or spare zone input allowing zone parameters to be programmed. Assigning an RF zone to a physical zone will override or ignore the zones physical hardware input terminals.



The control panel will need to be power cycled for the new volume settings to take effect.

Solution E Series and Solution 144 Panels						
Module Number	Address Setting					
	SW1	SW2	SW3	SW4	SW5	
1 =	OFF	OFF	OFF	OFF	OFF	
2 =	ON	OFF	OFF	OFF	OFF	
3 =	OFF	ON	OFF	OFF	OFF	
4 =	ON	ON	OFF	OFF	OFF	
5 =	OFF	OFF	ON	OFF	OFF	
6 =	ON	OFF	ON	OFF	OFF	
7 =	OFF	ON	ON	OFF	OFF	
8 =	ON	ON	ON	OFF	OFF	
9 =	OFF	OFF	OFF	ON	OFF	
10 =	ON	OFF	OFF	ON	OFF	
11 =	OFF	ON	OFF	ON	OFF	
12 =	ON	ON	OFF	ON	OFF	
13 =	OFF	OFF	ON	ON	OFF	
14 =	ON	OFF	ON	ON	OFF	
15 =	OFF	ON	ON	ON	OFF	
16 =	ON	ON	ON	ON	OFF	
Up to 16 x CM705B can be fitted to the Solution E Series panel. Up to 8 x CM705B can be fitted to the Solution 144 panel.						

Table 2: CM705B Address Configuration On Solution E Series and Vision X Panels



Address switch 5 is reserved for future use. You should leave this set to the off position when configuring the Solution E Series and Solution 144 panels.

Zone Wiring

Each CM705B universal expander installed on the system will be assigned a bank of 16 zone inputs regardless of the EOL resistor value programmed in the control panel.

When the end of line resistor value is set for single EOL or Alarm + Tamper, an optional CM707B Piggy Back Zone Input Expander Module can be fitted to the universal expander to allow an additional 8 zone input terminals. If the CM707B Piggy Back Zone Input Expander Module is not fitted, only the first bank of 8 zone inputs assigned to the universal expander can be hard wired and the second bank of 8 zones can only be utilised by an optional RF receiver and RF sensors.

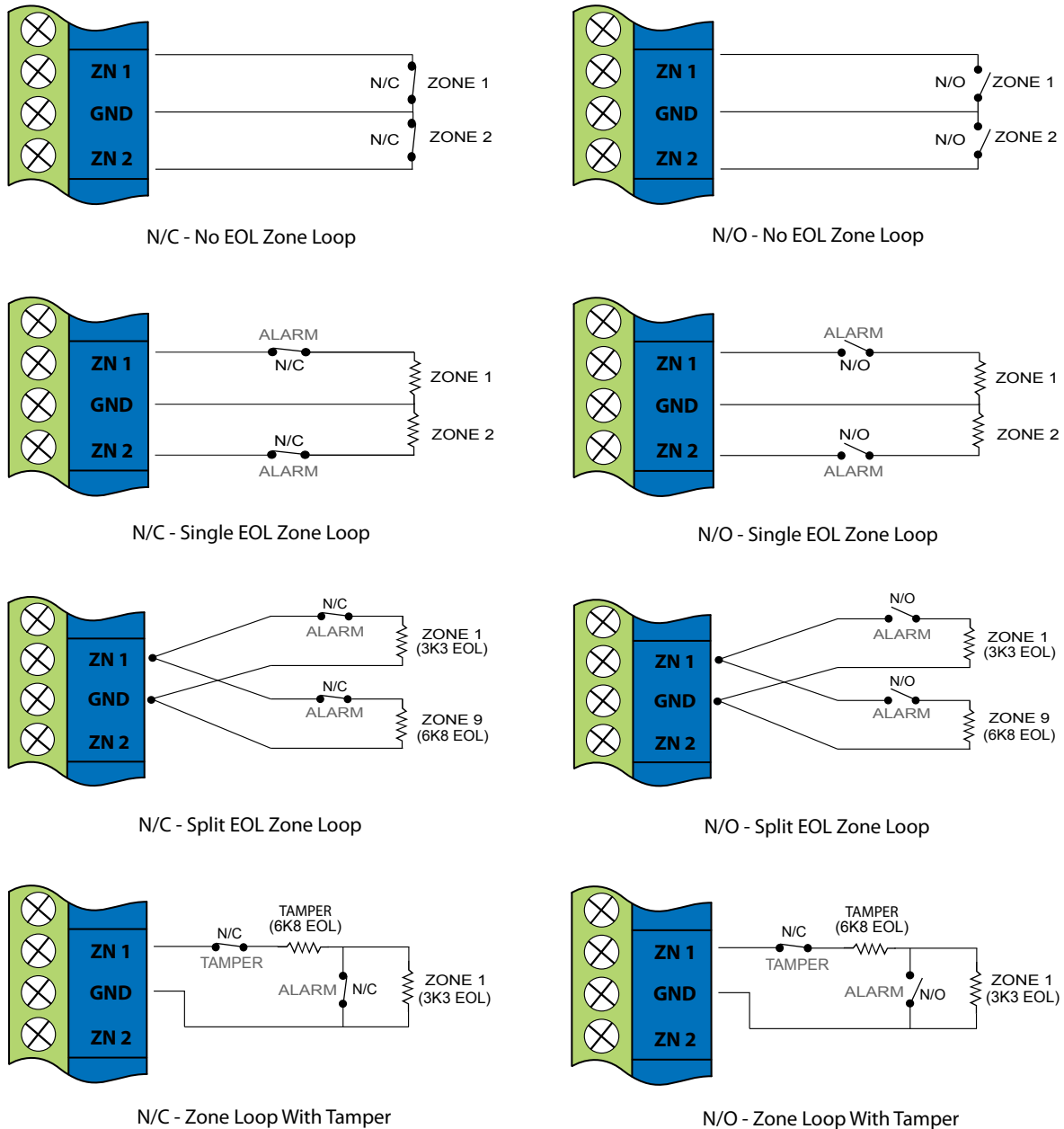

Figure 2 Zone Wiring Options

EOL Resistor Colours and Values

The universal expander is supplied with two values of EOL resistors to suit all possible wiring configurations. The resistors are colour coded as per below.

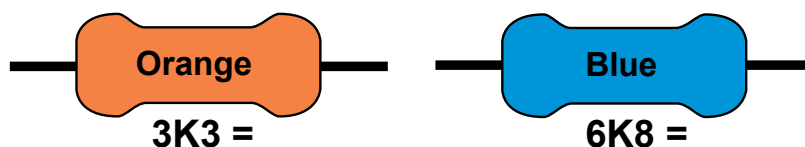

Figure 3: 3K3/6K8 Resistor Colours

CM705B Zone Input Allocation

The following table outlines the zone allocation for each universal expander module when using single EOL, alarm + tamper or split EOL. It also shows the effect on zone numbering when the optional CM707B is installed.

Solution E Series and Solution 144 Panels										
Module Number	Address Setting					Zone Numbers (Single EOL)	Zone Numbers (Alarm+Tamper EOL)	Single or Alarm + Tamper EOL With CM707B Module	Zone Numbers (Split EOL)	
	SW1	SW2	SW3	SW4	SW5					
1 =	OFF	OFF	OFF	OFF	OFF	17 to 24	17 to 24	17 to 24	17 to 32	
								25 to 32		
2 =	ON	OFF	OFF	OFF	OFF	33 to 40	33 to 40	33 to 40	33 to 48	
								41 to 48		
3 =	OFF	ON	OFF	OFF	OFF	49 to 56	49 to 56	49 to 56	49 to 64	
								57 to 64		
4 =	ON	ON	OFF	OFF	OFF	65 to 72	65 to 72	65 to 72	65 to 80	
								73 to 80		
5 =	OFF	OFF	ON	OFF	OFF	81 to 88	81 to 88	81 to 88	81 to 96	
								89 to 96		
6 =	ON	OFF	ON	OFF	OFF	97 to 104	97 to 104	97 to 104	97 to 112	
								105 to 112		
7 =	OFF	ON	ON	OFF	OFF	113 to 120	113 to 120	113 to 120	113 to 128	
								121 to 128		
8 =	ON	ON	ON	OFF	OFF	129 to 136	129 to 136	129 to 136	129 to 144	
								137 to 144		
9 =	OFF	OFF	OFF	ON	OFF	145 to 152	145 to 152	145 to 152	145 to 160	
								153 to 160		
10 =	ON	OFF	OFF	ON	OFF	161 to 168	161 to 168	161 to 168	161 to 176	
								169 to 176		
11 =	OFF	ON	OFF	ON	OFF	177 to 184	177 to 184	177 to 184	177 to 192	
								185 to 192		
12 =	ON	ON	OFF	ON	OFF	193 to 200	193 to 200	193 to 200	193 to 208	
								201 to 208		
13 =	OFF	OFF	ON	ON	OFF	209 to 216	209 to 216	209 to 216	209 to 224	
								217 to 224		
14 =	ON	OFF	ON	ON	OFF	225 to 232	225 to 232	225 to 232	225 to 240	
								233 to 240		
15 =	OFF	ON	ON	ON	OFF	241 to 248	241 to 248	241 to 248	241 to 256	
								249 to 256		
16 =	ON	ON	ON	ON	OFF	257 to 264	257 to 264	257 to 264	257 to 272	
								265 to 272		
Up to 16 x CM705B can be fitted to the Solution E Series panel. Up to 8 x CM705B can be fitted to the Solution 144 panel.										

Table 3: Zone Allocation Using Single EOL, Alarm + Tamper or Split EOL Values

Outputs

Each CM705B universal expander module includes 4 protected open-collector outputs that can be used to increase the number of programmable outputs available on the system. Each output is fully protected and can be configured to monitor for both open and short circuit output conditions.

Outputs can be used to operate LED indicators, operate relays to control garage doors, lighting, sprinklers, pumps, air conditioning or door strikes etc.

		Solution E Series and Solution 144 Panels						
		Module Number	Address Setting					Output Number
			SW1	SW2	SW3	SW4	SW5	
Solution 144 Panel	Solution E Series Panel	1 =	OFF	OFF	OFF	OFF	OFF	9 to 12
		2 =	ON	OFF	OFF	OFF	OFF	13 to 16
		3 =	OFF	ON	OFF	OFF	OFF	17 to 20
		4 =	ON	ON	OFF	OFF	OFF	21 to 24
		5 =	OFF	OFF	ON	OFF	OFF	25 to 28
		6 =	ON	OFF	ON	OFF	OFF	29 to 32
		7 =	OFF	ON	ON	OFF	OFF	33 to 36
		8 =	ON	ON	ON	OFF	OFF	37 to 40
		9 =	OFF	OFF	OFF	ON	OFF	41 to 44
		10 =	ON	OFF	OFF	ON	OFF	45 to 48
		11 =	OFF	ON	OFF	ON	OFF	49 to 52
		12 =	ON	ON	OFF	ON	OFF	53 to 56
		13 =	OFF	OFF	ON	ON	OFF	57 to 60
		14 =	ON	OFF	ON	ON	OFF	61 to 64
		15 =	OFF	ON	ON	ON	OFF	65 to 68
		16 =	ON	ON	ON	ON	OFF	69 to 72
Up to 16 x CM705B can be fitted to the Solution E Series panel. Up to 8 x CM705B can be fitted to the Solution 144 panel.								

Table 4: CM705B Address Configuration and Output Allocations

Programming

Output programming options are fully detailed in the control panel installation manual and quick reference guides. The following sequence outlines the correct output programming procedure.

1) Program the Output Name

Output names are used to simplify programming, user interaction and reporting.

2) Select the Output Event Type

Over 60 different event types are available to suit a variety of applications.

3) Program the Output Event Assignment

Assigns the output to a specific user, zone, area or door assignment etc.

4) Select the required Output Polarity

Configures how the output behaves (eg. operates for fixed period of time, pulses etc).

5) Program the Output Time Parameter

Sets how long the output will turn on or off for.

6) Select any required Output Options

Defines various options including to display or not display a trouble event when the output device is missing etc.

Power Supply

The CM705B universal expander module includes a 13.8V DC, 1 Amp power supply that can be used to provide power to sensors or other devices without the need to add a separate power supply module. Terminals to connect both a 16 to 18V AC 50-60 Hz plug pack and 12V DC 7.2AH sealed lead acid battery.

The module performs a battery test automatically every four hours as well as whenever an area is armed All On or Part On. The universal expander reports the backup battery condition as follows:

- Normal = 12.5V or above
- Low Battery = 11.5V
- Battery Missing = 10.2V

LAN Wiring

On installations with a large number of LAN powered devices (Keypads, Zone and Output Expanders etc) it may be necessary to provide additional power. To insure that the LAN+ voltage remains at an acceptable level, the CM705B universal expander can be added to the system to regenerate the LAN+ voltage as well as power additional sensors or other devices. If the CM705B is one of the two furthest modules from the control panel then you should install the LAN termination shunt.

The diagram below shows the correct method for wiring the CM705B when LAN+ re-generation is required.

CM797B LAN Isolator Modules can be used to increase the total LAN length to 1200m using the appropriate cable.

See the control panel quick reference guide for complete wiring instructions.

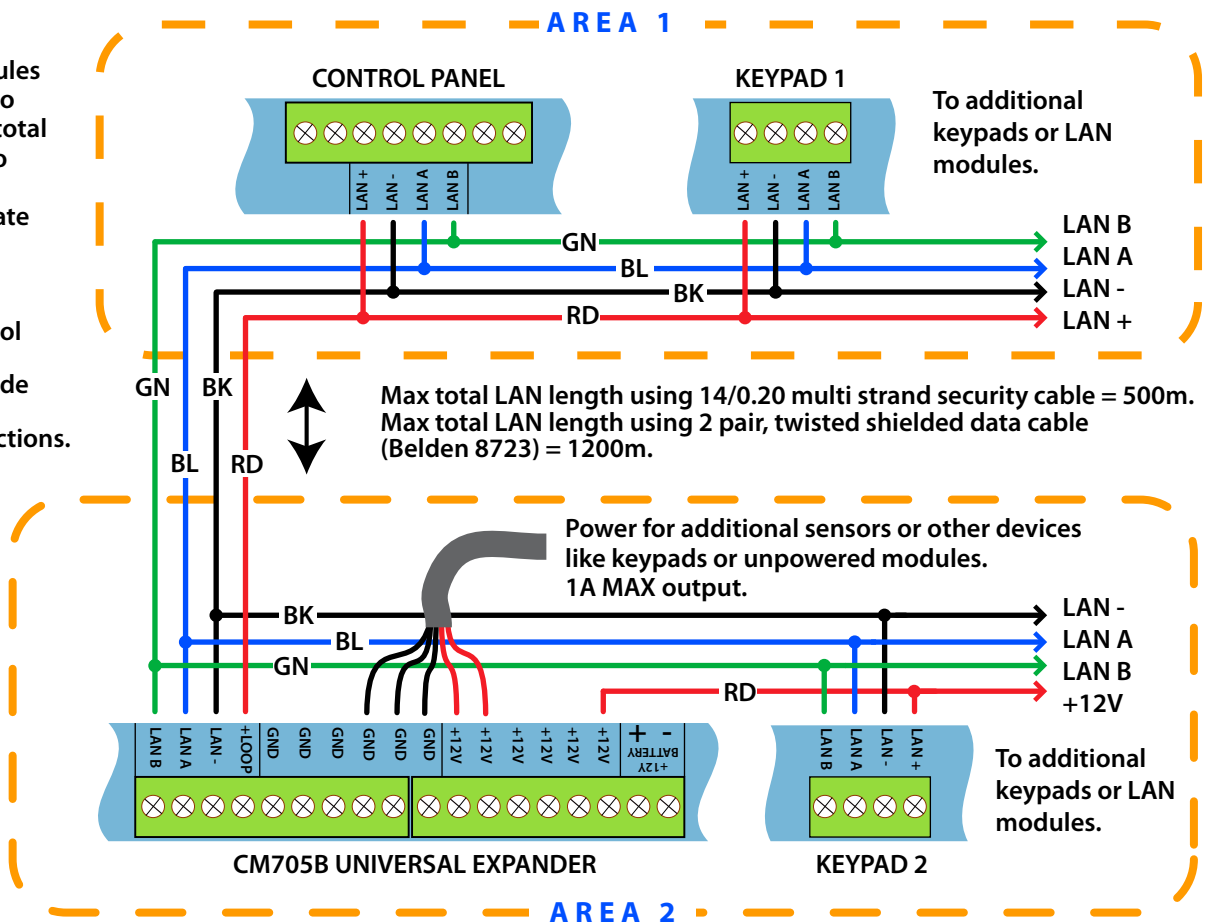

Figure 4: Connecting The CM705B Universal Expander and Regenerating The LAN+ Voltage

CM705B Connection Diagram

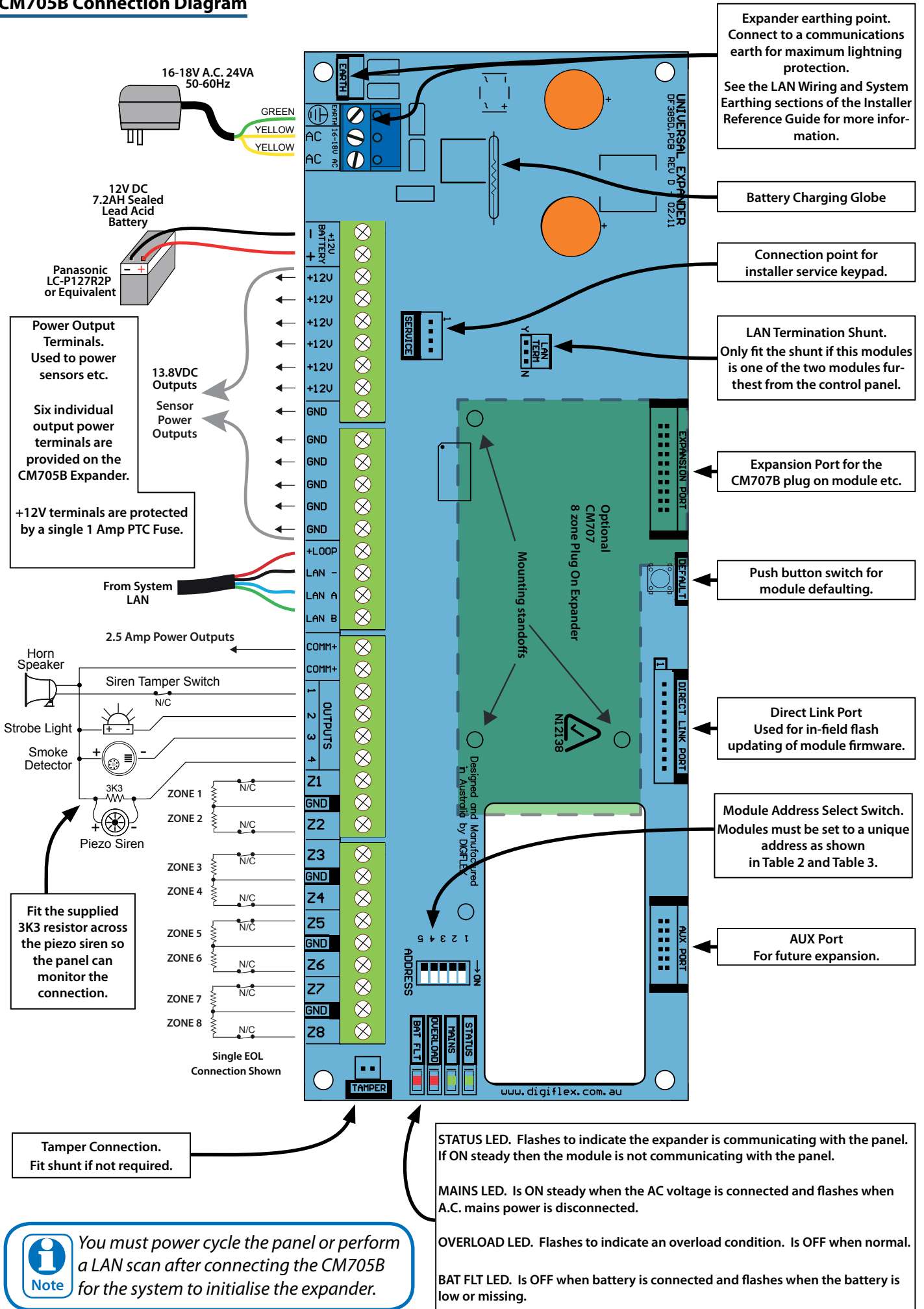

Figure 5: Connection Diagram

CM707B Plug On Zone Expander

The optional CM707B plug on module can be added via the expansion port on the CM705B universal expander to provide an additional 8 hard wired zone inputs bringing the CM705B universal expander to 16 hard wired zone inputs for Alarm + Tamper, 4 state monitoring or Single EOL configurations.

The module is supplied with both 3K3 and 6K8 EOL resistors and three plastic PCB standoffs to mount the module onto the CM705B universal expander. You should fit the standoffs to the expander first and then connect the CM707B module.

Installing The CM707B Module

- 1) Ensure that the CM705B universal expander and the control panel is powered down before proceeding.
- 2) Plug the 3 short plastic standoffs into the CM707B plug on module.
- 3) Install the CM707B plug on module onto the EXPANSION PORT of the CM705B universal expander, making sure that the plastic standoffs are also inserted into the holes provided on the CM705B universal expander.
- 4) Re apply power to both the CM705B universal expander and control panel.

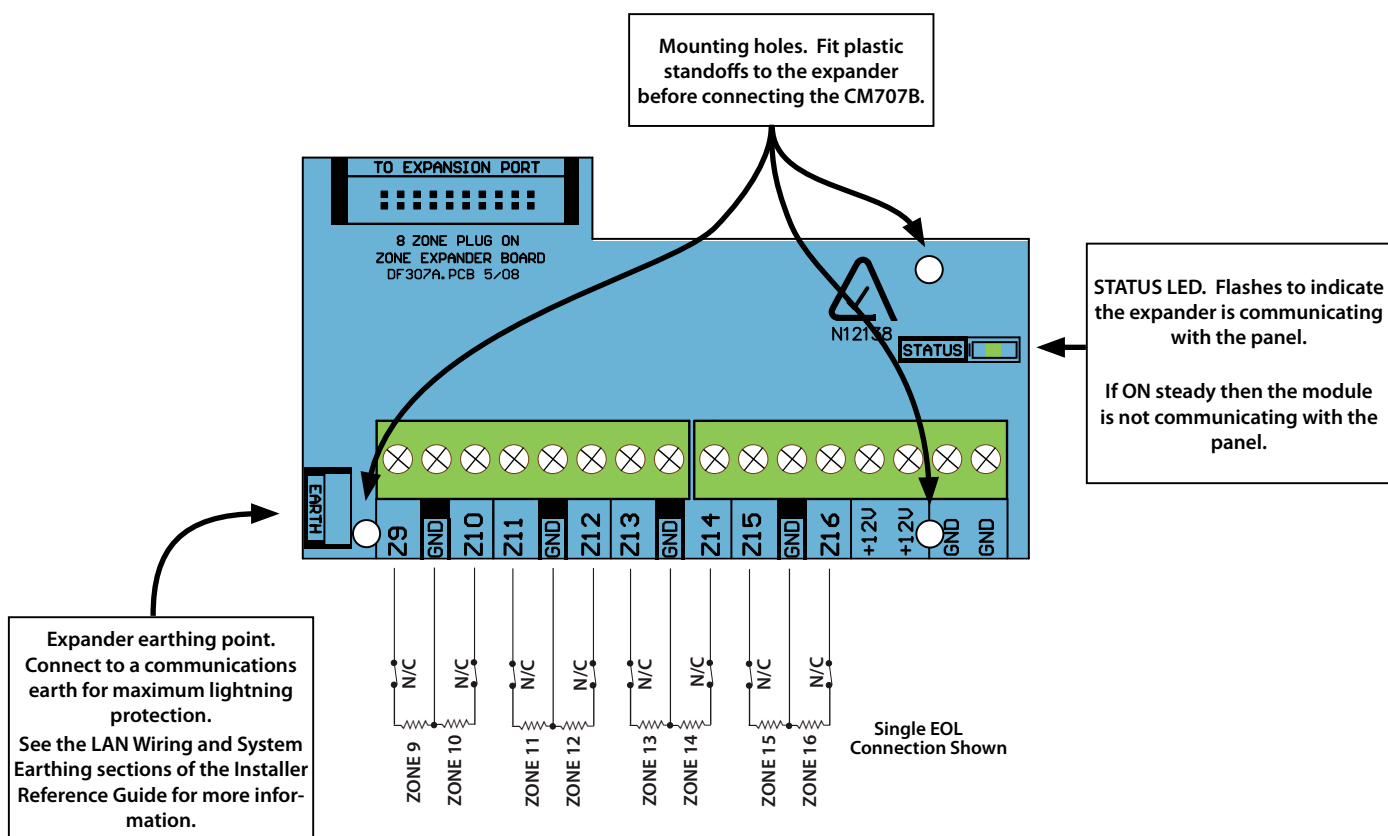

Figure 6: CM707B Plug On Zone Expander

Specifications

Part Number:	CM705B Universal Expander With Cabinet / CM705BP Universal Expander (PCB Only)
Operating Voltage:	10.0V DC - 14.5V DC @ 90mA Max
Voltage Input: (Primary Source)	16-18V AC 50-60Hz - 24VA External Power Adaptor or 220-240V AC to 18V AC 50-60 Hz - 24VA Internal Transformer
Stand-By Battery: (Secondary Source)	12V DC, 7.2AH sealed rechargeable battery Panasonic LC-P127R2P or equivalent
Module Connection: (RS485 LAN)	Max total LAN length using multi strand security cable = 500m,, Max total Lan length using 2 pair twisted shielded data cable (Belden 8723) = 1200m. See panel installation manual for complete LAN wiring instructions.
Programmable Outputs:	Four protected open-collector outputs capable of providing a maximum of 500mA (-) each. Outputs are monitored for short and open circuit and can monitor the state of horn speakers and other connected devices.
Power Output Terminals:	COMM+ - 2.5A high current output for use with on board outputs, PTC fuse protected. +12V - 1A outputs for use with detectors or powering other modules, PTC fuse protected.
Operating Environment:	0° to 55°C RH 5 to 85% at 30°C non-condensing
Fixing Method:	The CM705B is supplied in a metal enclosure. The CM705BP module only, can be mounted in either the MW700B or MW710B enclosures using clip in PCB mounts - supplied.
Warranty:	3 years from date of manufacture (return to base)



In the interest of ongoing product development this document is subject to change without notice.

Bosch Security Systems
25 Huntingwood Drive
Huntingwood, NSW 2148
Australia
Phone: +612 9672 1777
Facsimile: +612 9672 1717

© 2012 Bosch Security Systems
CM705BIRG

Issue FTR1.1

BOSCH