

# IKA

designed for scientists

**HABITAT** cell

**HABITAT** photo cell

**HABITAT** cell cct

**HABITAT** photo cell cct

**HABITAT** cell vessel

0.25 L sw

0.25 L dw

0.5 L sw

0.5 L dw

1 L sw

1 L dw

2 L sw

2 L dw

5 L sw

5 L dw

10 L dw

**HABITAT** ferment

**HABITAT** photo ferment

**HABITAT** ferment cct

**HABITAT** photo ferment cct

**HABITAT** ferment vessel

0.25 L dw

0.5 L dw

1 L dw

2 L sw

2 L dw

5 L sw

5 L dw

10 L dw

ENGLISH

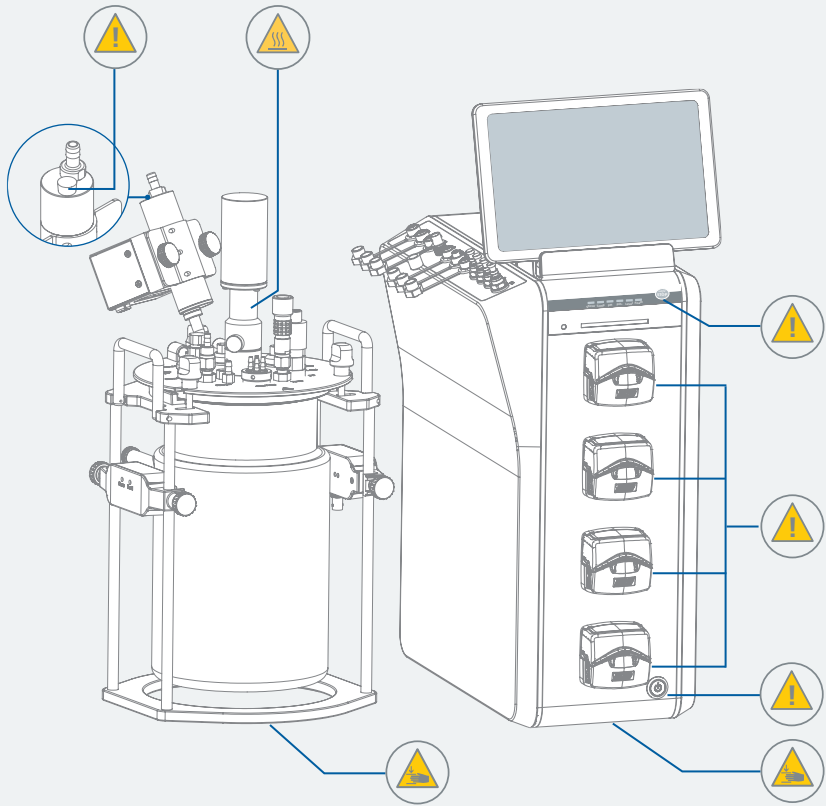











Fig. 1

	EU Declaration of conformity .....	6
	Note for USA (FCC) .....	6
	Note for Canada (IC) .....	6
	Explication of warning symbols .....	6
	Safety instructions .....	7
	Intended use .....	10
	Unpacking .....	11
	Useful information .....	15
	Installation .....	16
	Operation .....	34
	Interfaces and outputs .....	118
	Maintenance and cleaning .....	122
	Accessories .....	123
	Error codes .....	124
	Technical Data .....	129
	Warranty .....	137



## EU Declaration of conformity

We declare under our sole responsibility that this product corresponds to the directives 2014/35/EU, 2006/42/EC, 2014/30/EU and 2011/65/EU and conforms with the following standards or normative documents: EN 61010-1, EN 61010-2-051, EN 61326-1, EN 60529 and EN ISO 12100. Wireless module:

Directive: 2014/53/EU Standards: EN 60950-1, EN 300328, EN 301489-1, EN 301489-17  
A copy of the complete Declaration of Conformity or further declarations of conformity can be requested at [sales@ika.com](mailto:sales@ika.com).



## Note for USA (FCC)

This equipment complies with Part 15 of the FCC rules. Any changes or modifications not expressly approved by the Manufacturer could void the user's authority to operate the equipment. This device complies with Part 15 of the FCC rules subject to the following two conditions:

- (1) This device may not cause harmful interference, and
- (2) This device must accept all interference received, including interference that may cause undesired operation.

### NOTE:

This equipment has been tested and found to comply with the limits for a Class B digital device, pursuant to part 15 of the FCC Rules. These limits are designed to provide reasonable protection against harmful interference when the equipment is operated in a commercial environment. This equipment generates, uses, and can radiate radio frequency energy and, if not installed and used in accordance with the instruction manual, may cause harmful interference to radio communications. Operation of this equipment in a residential area is likely to cause harmful interference in which case the user will be required to correct the interference at his own expense.



## Note for Canada (IC)

This device complies with Industry Canada license-exempt RSS standard(s). Operation is subject to the following two conditions:

- (1) This device may not cause interference
- (2) This device must accept any interference, including interference that may cause undesired operation of the device.

This device complies with Health Canada's Safety Code 6 / IC RSS-210. The installer of this device should ensure that RF radiation is not emitted in excess of the Health Canada's requirement.



## Explication of warning symbols

### /// Warning symbols

**Danger!** Indicates an (extremely) hazardous situation, which, if not avoided, will result in death, serious injury.

**Warning!** Indicates a hazardous situation, which, if not avoided, can result in death, serious injury.

**Caution!** Indicates a potentially hazardous situation, which, if not avoided, can result in injury.

**Notice!** Indicates practices which, if not avoided, can result in equipment damage.

**Danger!** Indicates the exposure to a hot surface.

**Caution!** Indicates crushing risk to fingers / hands.

### /// General Symbols

**A** Position number  
Indicates device components relevant to actions.

Correct / result  
Indicates the correct execution or the result of an action step.

Wrong  
Indicates the incorrect execution of an action step.

Note  
Indicates steps of actions that require particular attention.

Closed lock  
Indicates the status of "locked".

Open lock  
Indicates the status of "Unlocked".

## Safety instructions



### /// General information

- > **Read the operating instructions completely before starting up and follow the safety instructions.**
- > Keep the operating instructions in a place where it can be accessed by everyone. The operating instructions are also available as a PDF or can be downloaded from the user interface and also from the IKA homepage.
- > Ensure that only trained staff work with the device.
- > Follow the safety instructions, guidelines, occupational health and safety and accident prevention regulations.
- > The device must only be used in a technically perfect condition.

**Notice!**  
> Pay attention to the marked sites in **Fig. 1**.

### /// Device design

#### **Caution!**

- › The power switch of the device must be accessed immediately, directly and without risk at any time. If access to the power switch cannot be ensured, an additional emergency stop switch that can be easily accessed must be installed in the work area.
- › Ensure that your hands / fingers do not get crushed when setting down the device.

#### **Caution!**

- › Device surface is partially made of glass:
  - Glass surface can be damaged by impact.
  - If glass surface is damaged it could cause injury, don't use the device anymore.

#### **Notice!**

- › Set up the device in a spacious area on an even, stable, clean, non-slip, dry and fireproof surface.
- › The feet of the device must be clean and undamaged.
- › Ensure that the vessel stands safely on the device.

### /// Working with the device

#### **Danger!**

- › Do not use the device in explosive atmospheres, it is not EX-protected.
- › With substances capable of forming an explosive mixture, appropriate safety measures must be applied, e.g. working under a fume hood.
- › To avoid body injury and property damage, observe the relevant safety and accident prevention measures when processing hazardous materials.
- › Before use, the vessel system has to be cleaned and sterilized.
- › The device is not suitable for hand-held operation.
- › Do not touch the rotating parts during operation!
- › Autoclaving: 121 °C / 25 ... 30 minutes  
Do not close the hose jacket connectors for the temperature chamber of the double-wall glass vessel while autoclaving! The vessel might get broken! Be aware of the hot surface after autoclaving!
- › Turn off the peristaltic pumps before replacing any tubes or pump heads.
- › During autoclaving, there must be no water in the condenser. Fill the condenser with water only after autoclaving! For autoclaving remove the filling screw of the condenser.

#### **Danger!**

- › **Working with gases:**
  - Gases can be hazardous to the health.
  - Observe the general safety instructions for the handling of gases!
  - Carry out regular training of personnel for the handling of gases.
  - When connecting the supply lines, ensure correct connections and the maximum permissible connection pressures!
  - Only work with the original accessories, and check that they are in perfect condition before operating the device!
  - Close the gas supply at the end of the experiment.
  - Determine the possible concentration of the escaping gases at the outlet of the bioreactor.
  - Use all the necessary gases only in the quantities required, and make sure that the atmosphere is not enriched with them.
  - Ensure sufficient ventilation at the workplace.
  - Observe the current safety data sheets for the gases used.
- › **Working with oxygen / O<sub>2</sub>:**
  - As a compressed gas, oxygen is oxidising; aids intensive combustion; can react violently with flammable materials.
  - Observe the general safety instructions for the handling of gases (see above).
  - The presence of oxygen reduces the ignition temperature and the necessary ignition

energy of a combustion and increases the fire temperature.

- Keep possible ignition sources (open flames, hot surfaces) away.
- Do not use oils or greases in the area containing oxygen (fittings, connections).
- Use oxygen only in the quantities required, and make sure that the atmosphere does not become enriched with oxygen.
- Ensure sufficient ventilation at the workplace.
- › **Working with nitrogen / N<sub>2</sub>:**
  - Nitrogen is odorless and leads to asphyxiation in high concentrations!
  - Observe the general safety instructions for the handling of gases (see above).
  - Do not use oils or greases in the nitrogenous area (fittings, connections).
- › **Working with carbon dioxide / CO<sub>2</sub>**
  - Carbon dioxide is a non-flammable, acidic and colorless gas. High concentrations can be fatal due to oxygen deficiency.
  - Observe the general safety instructions for the handling of gases (see above).
  - CO<sub>2</sub> is produced during fermentation processes, among other things. Pay particular attention to good ventilation and connect the exhaust air duct of the bioreactor to a suitable extraction device.
  - Keep this in mind when using larger quantities of CO<sub>2</sub> for pH regulation.

#### **Warning!**

- › Only process media that will not react dangerously to the extra energy produced through processing. This also applies to any extra energy produced in other ways, e.g. through light irradiation.
- › Beware of hazards due to:
  - flammable materials,
  - glass breakage,
  - overfilling of media,
  - rotating parts.
- › When handling hazardous substances or mixtures of substances which are toxic or are contaminated with pathogenic micro-organisms, the user should take appropriate precautions. Observe the national regulations, the biosafety level of your laboratory, the material safety data sheets.
- › For germs or biological material or risk group II or higher, please observe the "Laboratory Biosafety Manual" issued by the World Health Organization).
- › It may be possible for wear debris from rotating accessory parts to reach the material being processed.
- › The operation of a free rotating shaft end is prohibited.
- › Excessive or negative pressure can damage the glass reactor vessel.
- › Do not use damaged hoses.
- › Check all connections for leaks, especially all gas connections.

#### **Caution!**

- › Wear your personal protective equipment in accordance with the hazard category of the media to be processed. There may be a risk from:
  - ejection of parts,
  - release of toxic or combustible gases,
  - splashing and evaporation of liquids,
  - parts with hot surfaces.
- › Stop operating if:
  - the medium splashes out of the vessel because the speed is too high,
  - the device is not running smoothly,
  - the device begins to move around because of dynamic forces,
  - an error occurs.

#### **Notice!**

- › Remove the motor, the sensor cables and the foam sensor before autoclaving. Other parts are autoclavable.
- › Cover the sensor connections during autoclaving (for example with aluminum foil).

- › Covers or parts that can be removed from the device without tools must later be refitted to ensure safe operation.
- › There may be electrostatic activity between the medium and the output shaft which could cause a direct danger.
- › Never operate the device with the stirrer tools rotating freely. Ensure that parts of the body, hair, jewelry or items of clothing cannot be trapped by the rotating parts.
- › Pay attention when setting the speed to any imbalance of the stirrer tools and possible spraying of the medium to be stirred.

### /// Accessories

- › Protect the device and accessories from bumping and impacting.
- › Check the device and accessories for damage before each use. Do not use damaged components.
- › Safe operation is guaranteed only with the use of original IKA accessories.
- › Ensure that the external temperature sensor is inserted into the medium to a depth of at least 20 mm when connected.
- › Observe the operating instructions of the accessories.

### /// Power supply / Switching off the device

#### ⚠ Warning!

- › After a power failure during operation, the device may start automatically (depending on the operating mode).
- › Restart PC / App and the IKA HABITAT software if a software failure occurs. IKA HABITAT will run without an active connection with PC / App.
- › The voltage stated on the type plate must correspond to the mains voltage.
- › The device can only be disconnected from the power supply by pulling out the mains plug or the connector plug.
- › The device must only be operated with the original power cord set.
- › The socket for the power cord must be easily accessible.
- › Socket must be earthed (protective ground contact).
- › Replace the fuses only after disconnecting the device from the power supply by pulling out the mains plug. The fuse value must correspond to the value on the serial license plate.

### /// Maintenance

- › The device may only be opened by qualified and approved experts. The device must be unplugged from the power supply before opening. Live parts inside the device may still be live for some time after unplugging from the power supply.
- › Only use original IKA spare parts!

### /// Disposal instructions

- › The device, accessories and packaging must be disposed of in accordance with local and national regulations.



## Intended use

### /// Use

- › Bioreactors are designed to run cell growth or fermentation processes.

### /// Area of use

- › Indoor environments similar to that a laboratory of research, teaching, trade or industry area.
- › The safety of the user cannot be guaranteed:
  - if the device is operated with accessories that are not supplied or recommended by the manufacturer,
  - if the device is operated improperly or contrary to the manufacture's specifications,
  - if the device or the printed circuit board are modified by third parties.

## Unpacking

### /// Unpacking

- › Unpack the device carefully. Any damage should immediately be reported to the carrier (mail, rail or freight forwarding company).

### /// Scope of delivery

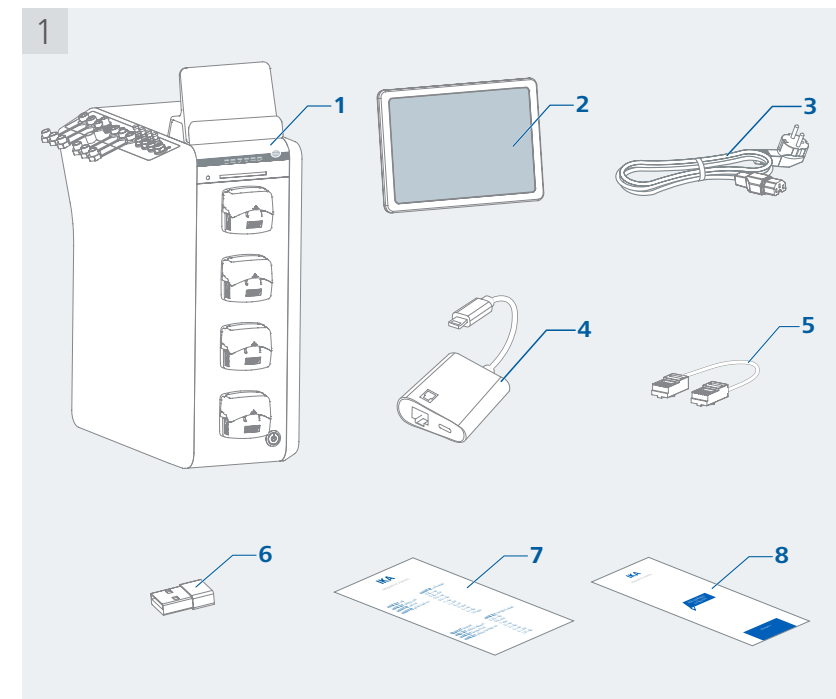

1	HABITAT cell / ferment	5	LAN cable 1 m
2	Tablet PC	6	USB-C Adapter
3	Power cord set H 11	7	User guide
4	USB-C to Ethernet Adapter	8	Warranty card

\* For ferment only    \*\* For SW 2&5 L ferment only

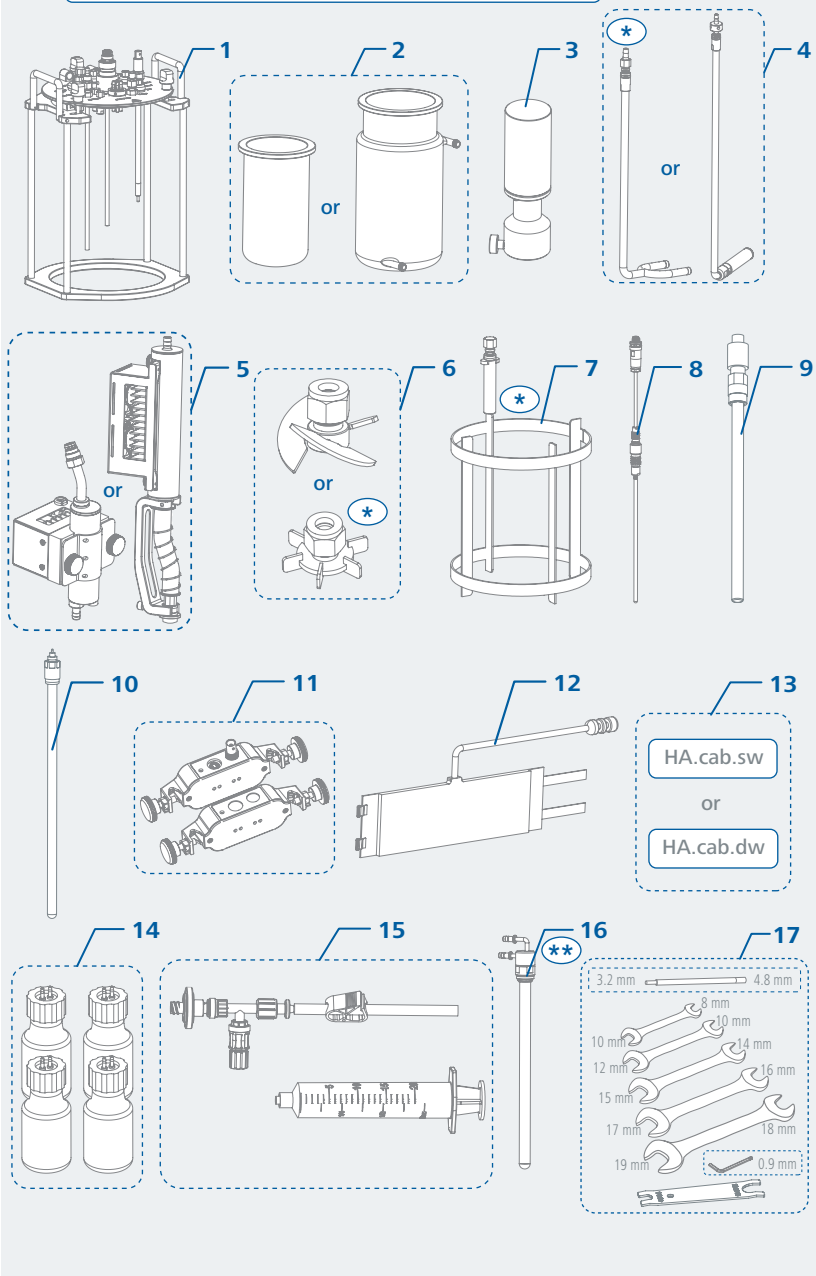

1	HA.vh.x vessel holder incl. HA.lc.x lid mounted
2	HA.gv.sw.x (vessel single wall) or HA.gv.dw (vessel double wall)
3	HA.mt.s.x (Motor)
4	HA.sp.m.x (Micro sparger) or HA.sp.r.x* (Ring sparger)
5	HA.cn HA.cn.flx
6	HA.ip.pi.x (Impeller 3-pitch blade) or HA.ip.b.x* (Impeller 6 blade) (for vessel size 5 / 10 L, 2x)
7	HA.ba.x* (Baffle, not available for 0.25 L)

8	HA.s.tm.x (Temperature sensor)
9	HA.s.ph.x (pH sensor)
10	HA.s.do.x (DO sensor)
11	HA.s.fo (Foam sensor)
12	HA.hbl.x (Heat blanket)
13	HA.cab.sw (cable set for single wall) or HA.cab.dw (cable set for double wall)
14	HA.sf.250 (Bottle 250 ml x4)
15	HA.sam (Syringe set)
16	HA.cf.x (Cooling finger)**
17	Tool set

**Note:** "x" refers to the number of the vessel size like 0.5, 1, 2, 5 or 10, e.g. 2 L « HA.gv.sw.2; 0.5 L « HA.gv.sw.0.5.

Abbreviations:  
sw: single wall  
dw: double wall

**HA.cn is used for:**  
cell / ferment sw / dw 0.25 L  
cell / ferment sw / dw 0.5 L  
cell / ferment sw / dw 1 L  
cell / sw / dw 2 L

**HA.cn.flx is used for:**  
cell / ferment sw / dw 5 L  
cell / ferment dw 10 L  
ferment sw / dw 2 L

3

HA.cab.sw

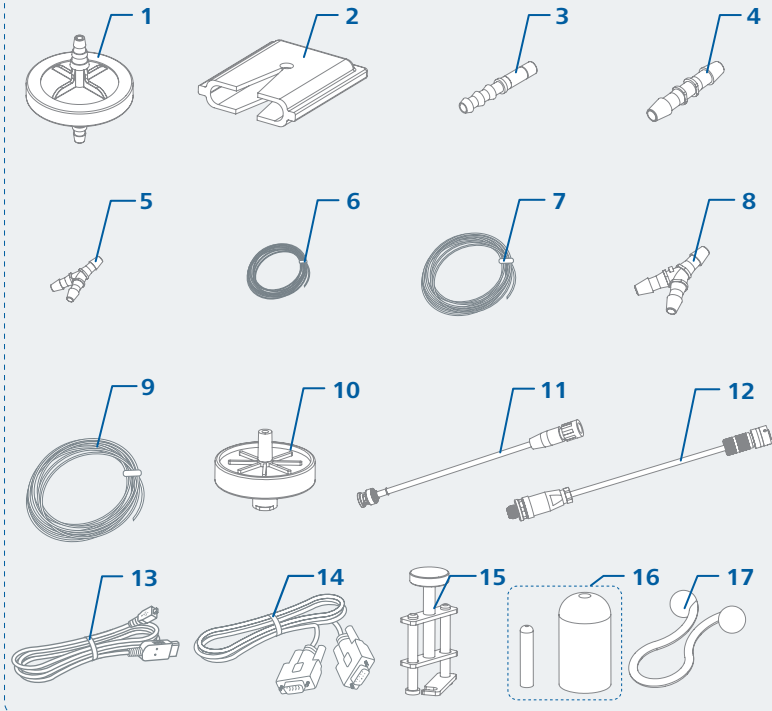

HA.cab.dw

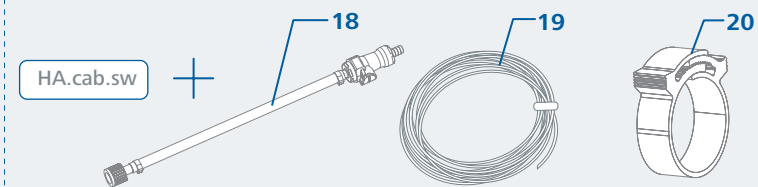

1	Filter (2x)
2	Filter heater
3	Plug in barb connector 6 mm x 5 mm (8x)
4	Hose reducer 6.4 mm x 3.9 mm (2x)
5	Y hose connector 3.2 mm (3x)
6	Silicone tube 3.2 mm x 6.4 mm x 7.5 m
7	Silicone tube 4.8 mm x 9.5 mm x 3 m
8	Y hose connector 4.8 mm (3x)
9	PUN tube OD 6 mm x 10 m
10	Filter (4x)
11	pH cable

12	DO cable
13	USB cable
14	RS 232 cable
15	Hose clamp (5x)
16	Silicone cap: ID 3.5mm x 25.4 mm (10x) ID 13.6 mm x 38 mm (2x)
17	Twist tie (10x)
18	Hose with GL18 and quick coupling (2x)
19	Silicone tube 8 mm x 12.7 mm x 5 m
20	Hose clamp (4x)

## Useful information

- › The HABITAT is operated with an iOS Tablet PC (included in the scope of delivery).
- › Alternatively, the operation is also available via an MS-Windows® PC / notebook.
- › Wired and wireless operation is supported. Monitoring is also available for an iOS mobile system by means of the Bioreactor App.
- › During the process, the Tablet PC or notebook can be decoupled from the device. The device works independently of the user interface software. All data is stored in the device.
- › The status of the main device parameters is indicated by a LED bar. (see "Alarm setting")
  - Green LED:** ok, within the limit values
  - Orange LED:** not ok, out of the limit values
  - Red LED:** not ok, an error has occurred
- › When the Tablet PC / notebook is reconnected, all data from the device is transferred to the software of the Tablet PC / notebook and displayed.
- › **Safe-STOP button:** Immediately pause all actuators (Stirrer, Heater, Pumps, MFCs / Mass-flow Controllers, Thermostat, Light panel).
  - Safe-STOP:** Press the button at the control unit / or the button on GUI. All actuators stop.
  - Exit Safe-STOP:** Press the button on the control unit again (not in the software). All actuators are switched on again according to the settings.
- › **Mains switch:** Switch on / off the device
  - Power-ON:** Control unit on, ready to start
  - Power-OFF:** Control unit off, no power supply

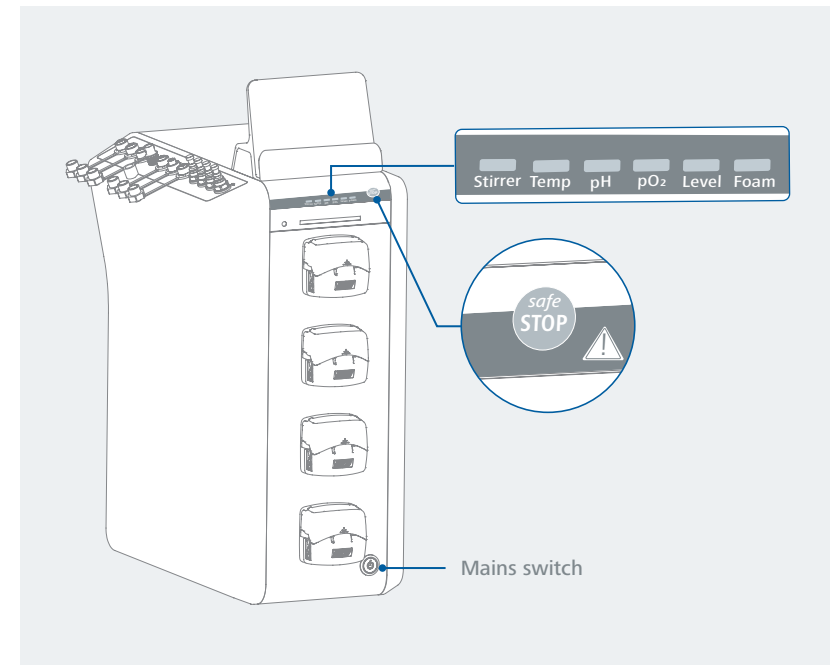

### ⚠ Notice!

- › The data log file is only active after the "Experiment" has been started. After pressing the "Play" menu button in the software, all data from "Start" to "Stop" are recorded. An experiment can only be created with a single name.
- › In safe-STOP mode, the data will continue to be recorded. The log file shows that all actuators have been stopped for the duration of the safe-STOP.



# Installation

/// Gas

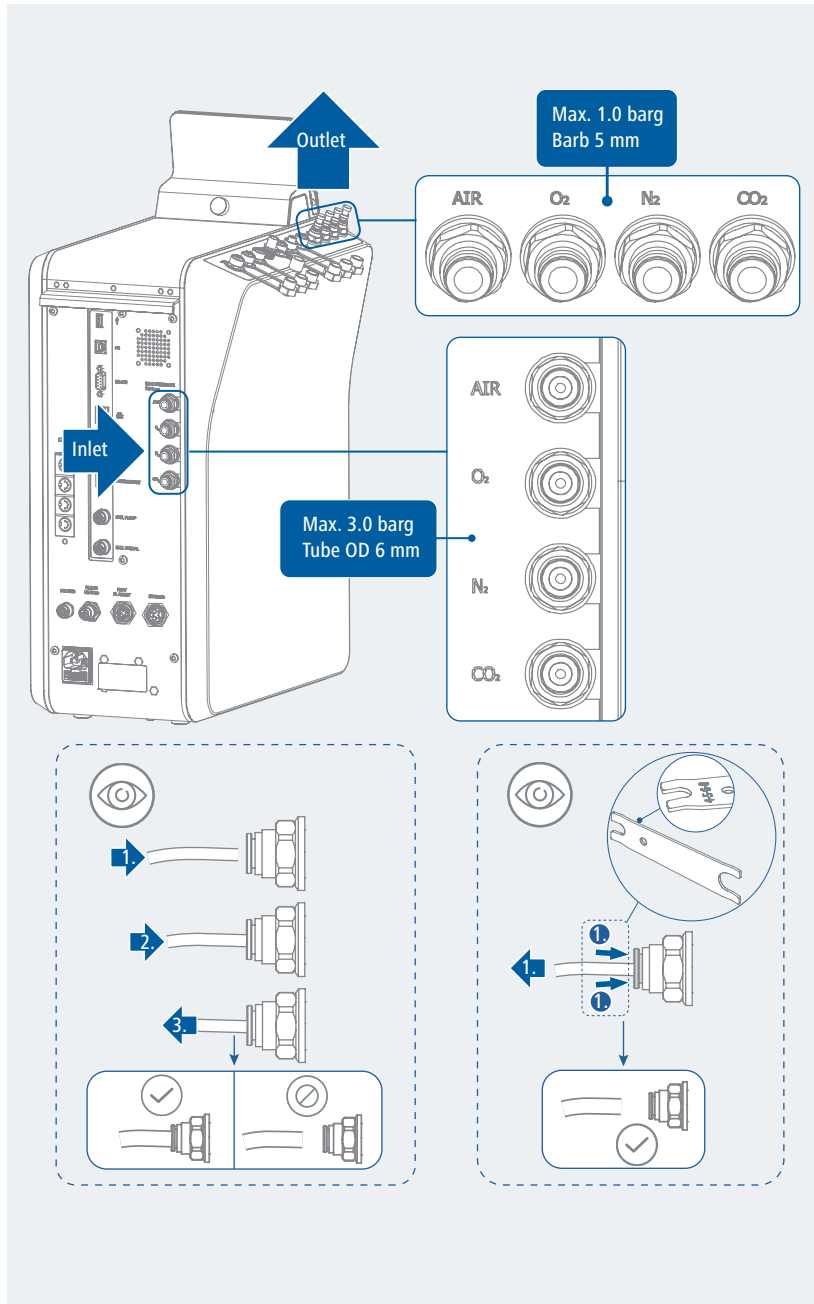

# /// Interfaces

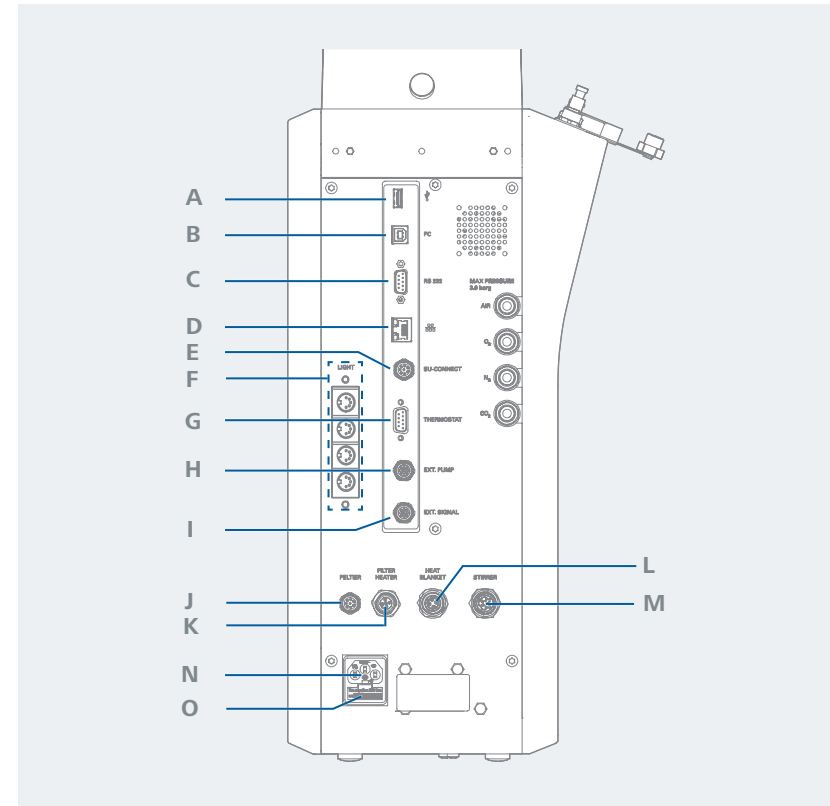

A	USB	USB connection (data storage)
B	PC	PC connection (communication with GUI software)
C	RS-232	RS 232 connection (communication with GUI software)
D	ETHERNET	Ethernet connection (communication with GUI software)
E	SU-CONNECT	Sensor connection SU Vessel
F	LIGHT	Light panel connection
G	THERMOSTAT	Thermostat connection
H	EXT. PUMP	External pump connection
I	EXT. SIGNAL	Connection 4...20 mA
J	PELTIER	Peltier cooling connection
K	FILTER HEATER	Filter heater connection
L	HEAT BLANKET	Heat blanket connection
M	STIRRER	Stirrer connection
N	POWER SOCKET	Power supply connection
O	FUSE SOCKET	Position of fuses

/// Vessel

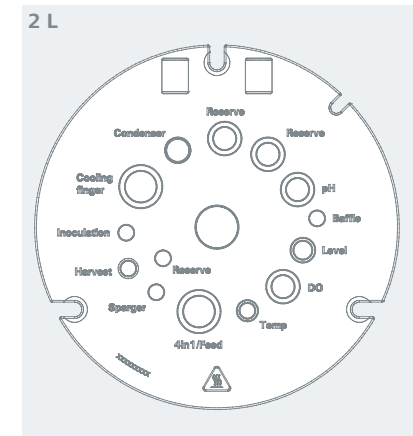
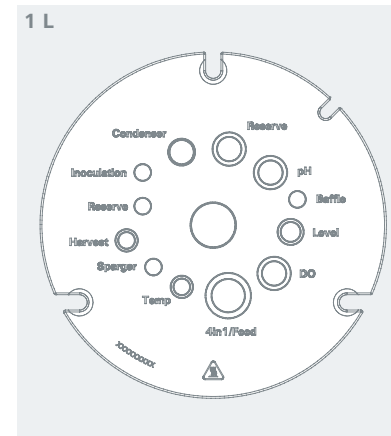
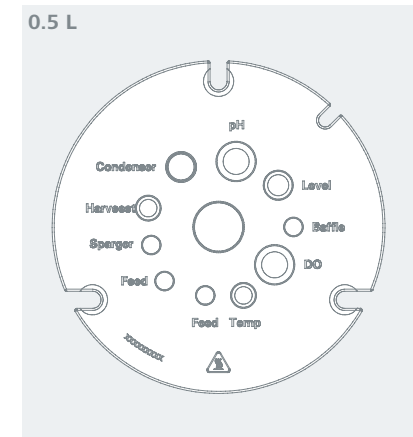
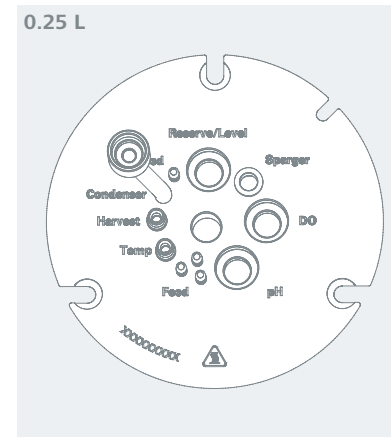
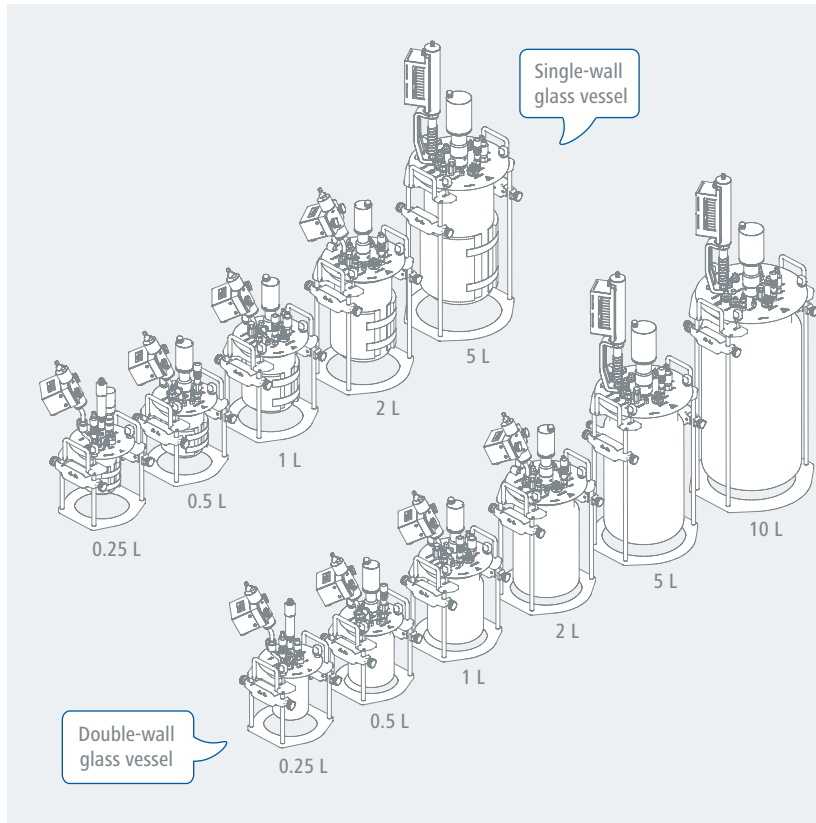

/// Lid

Ports	Port sizes					
	0.25 L	0.5 L	1 L	2 L	5 L	10 L
Temp	4 mm				M10	
DO					Pg13.5	
Level	Pg13.5				M12	
Baffle	-				11 mm	
pH					Pg13.5	
Exhaust cooler					M16	
Harvest	4 mm				M10	
Sparger					11 mm	
Feed	barb 5 mm (x3)	11 mm (x2)	-	-	-	-
4in1/Feed	-	-			M27	
Cooling finger	-	-	-		M27	
Inoculation	-	-	11 mm (x1)	11 mm (x1)	11 mm (x1)	11 mm (x1)
Reserve Pg13.5	x1 (if level not in use)	-	x1	x2	x3	x4
Reserve 11 mm	-	-	x1	x1	x1	x2
Reserve M27	-	-	-	-	-	x1

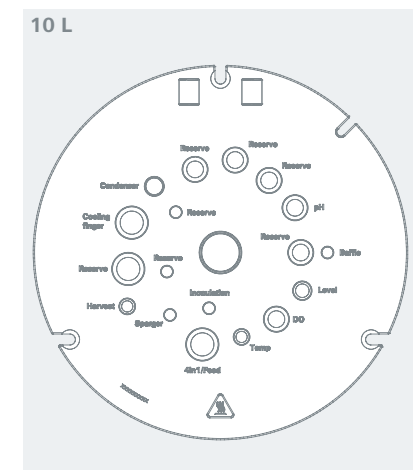
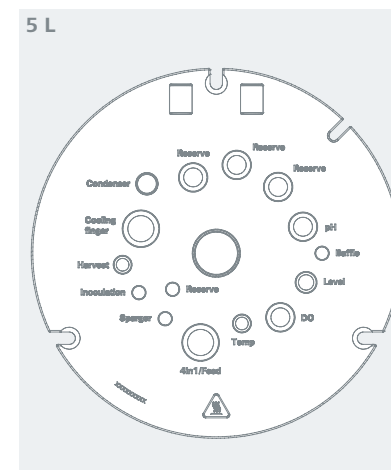

/// Lid with plugs and fittings

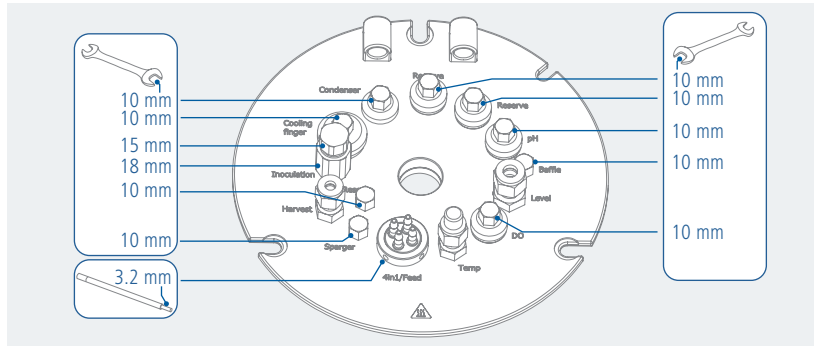

/// Drive shaft

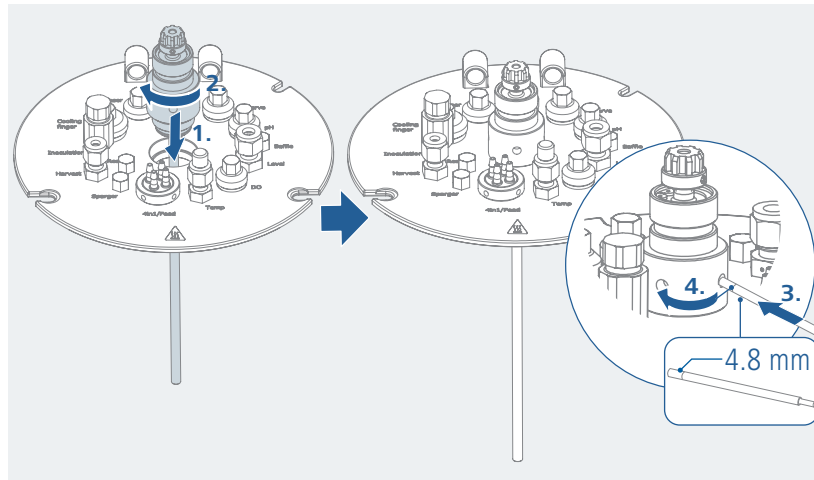

/// Impeller

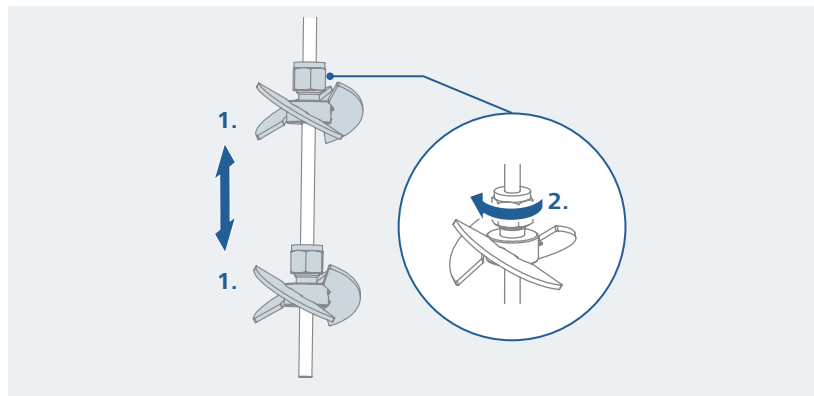

/// Harvest pipe

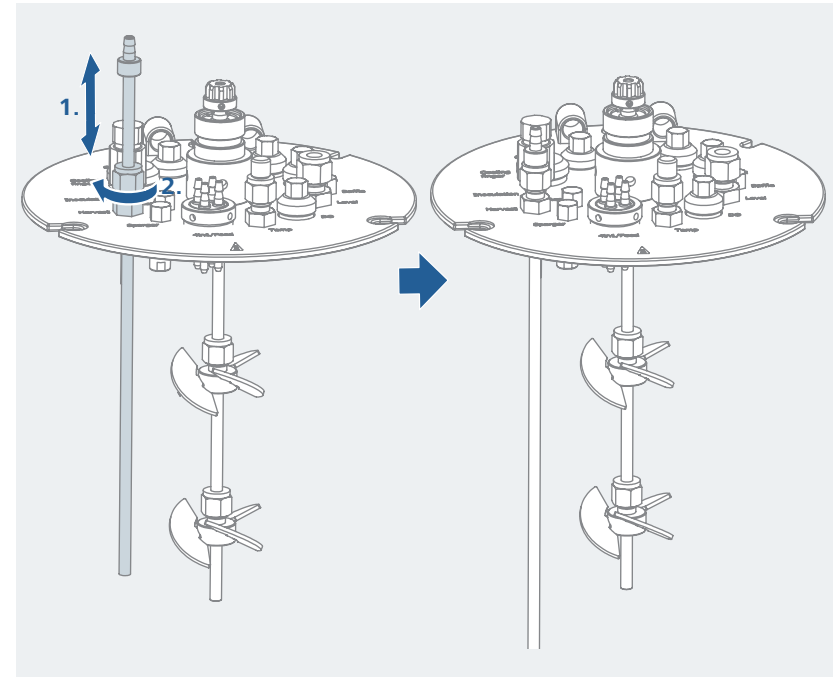

/// Ring or micro sparger

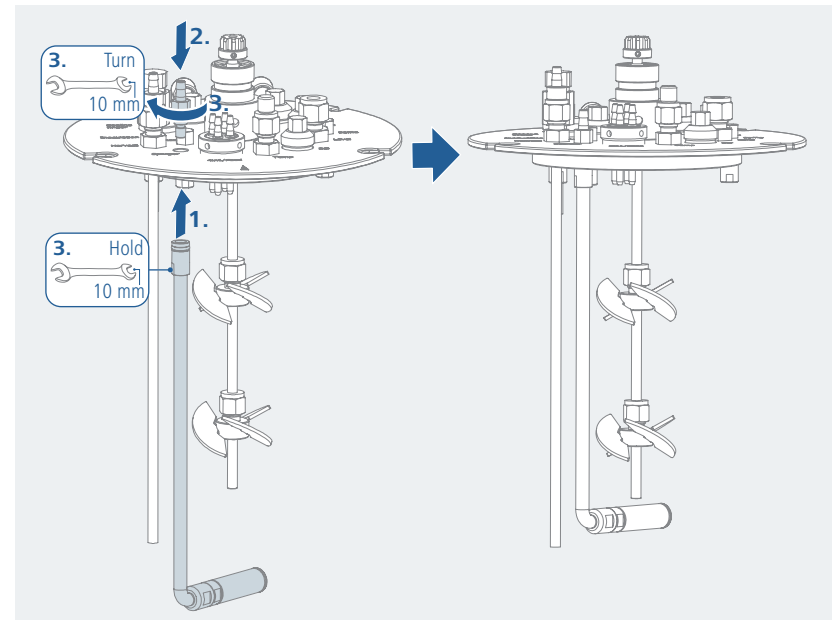

### /// Baffle

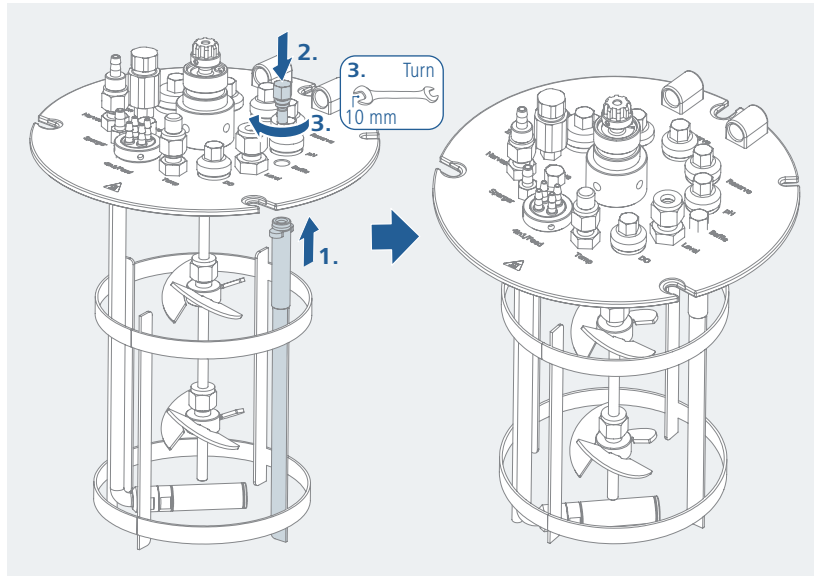

### /// Level sensor

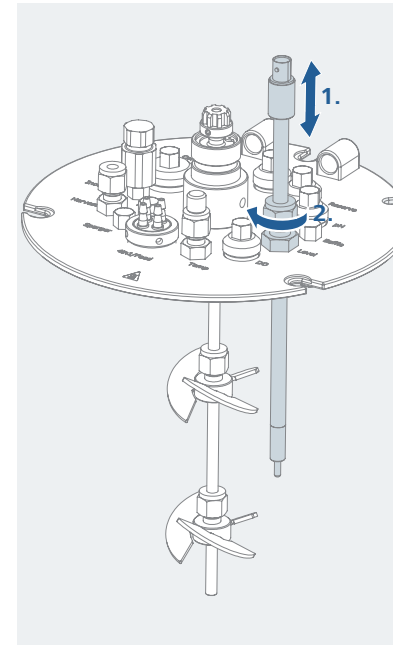

### /// Temperature sensor

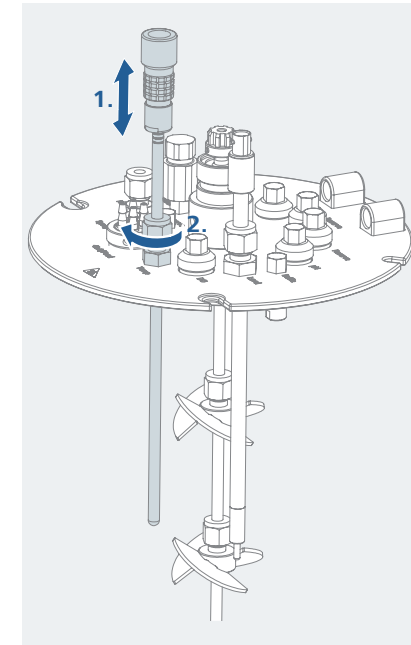

### /// Condenser

#### ⊗ **Danger!**

› During autoclaving, there must be no water in the condenser. Fill the condenser with water only after autoclaving! For autoclaving remove the filling screw of the condenser.

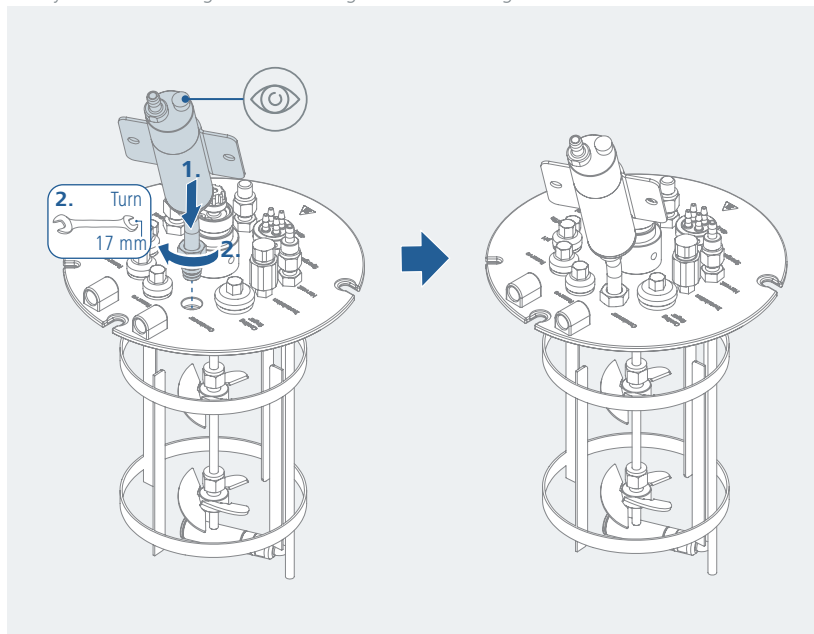

### /// DO, pH, CO<sub>2</sub>, conductivity or turbidity probe

#### ⊗ **Caution!**

› Read the operating instructions for the probes carefully!

#### ⚠ **Notice!**

› Related on the lid size the ports may vary!

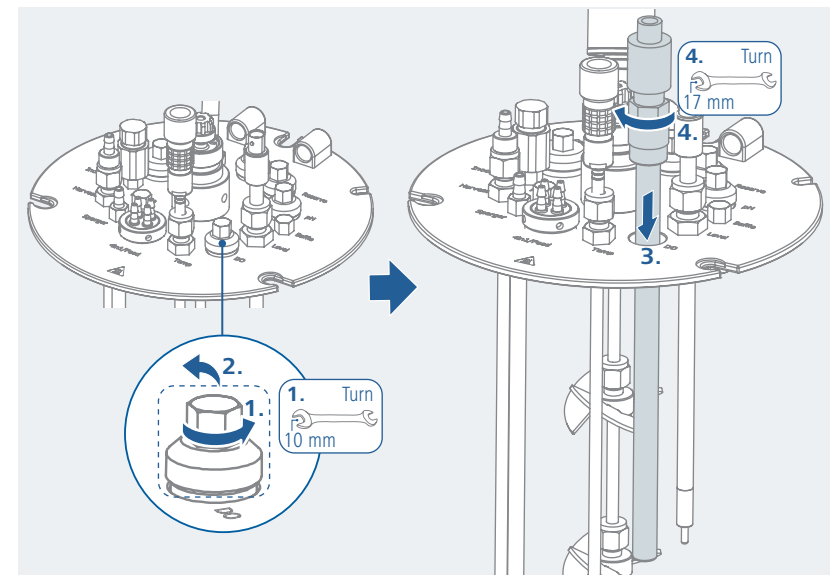

### /// Spin filter (accessories)

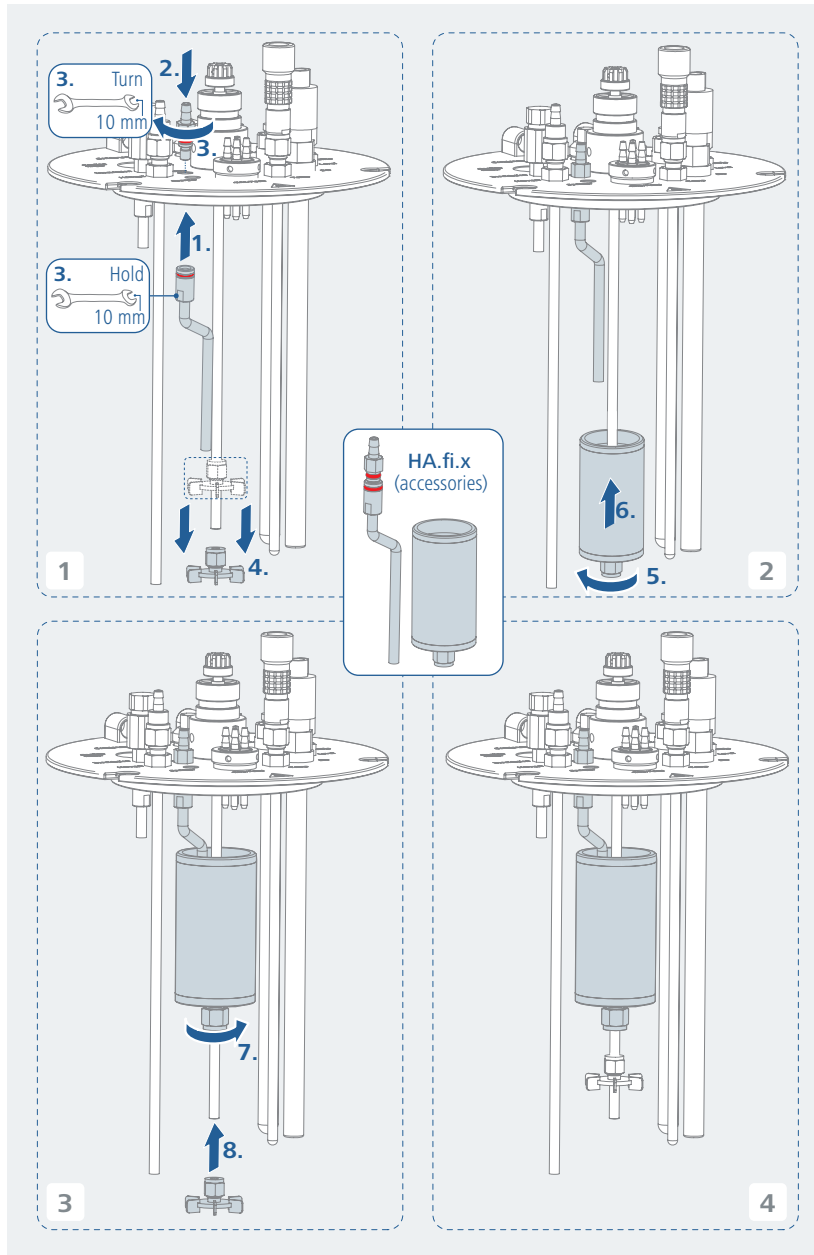

### /// Vessel and stand

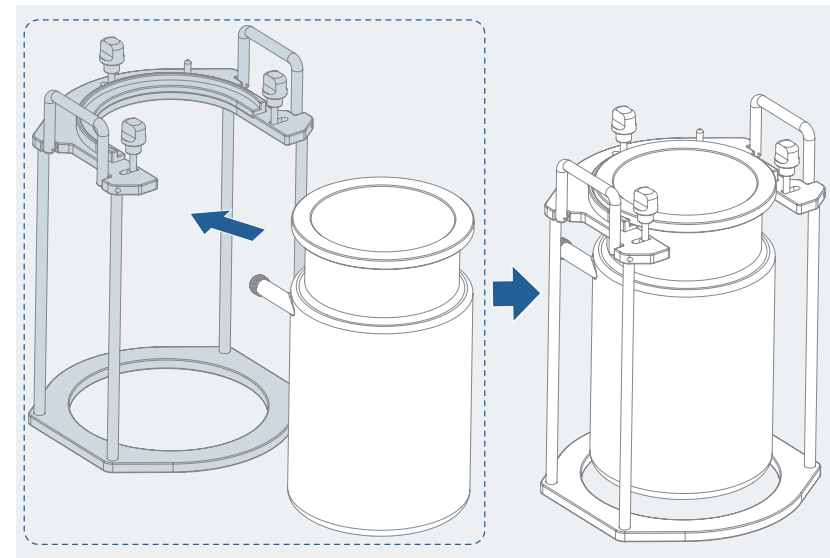

### /// Lid and vessel

#### ⚠ Notice!

› Check the presence of the lid sealing. Never work without the lid seal. Risk of glass breakage.

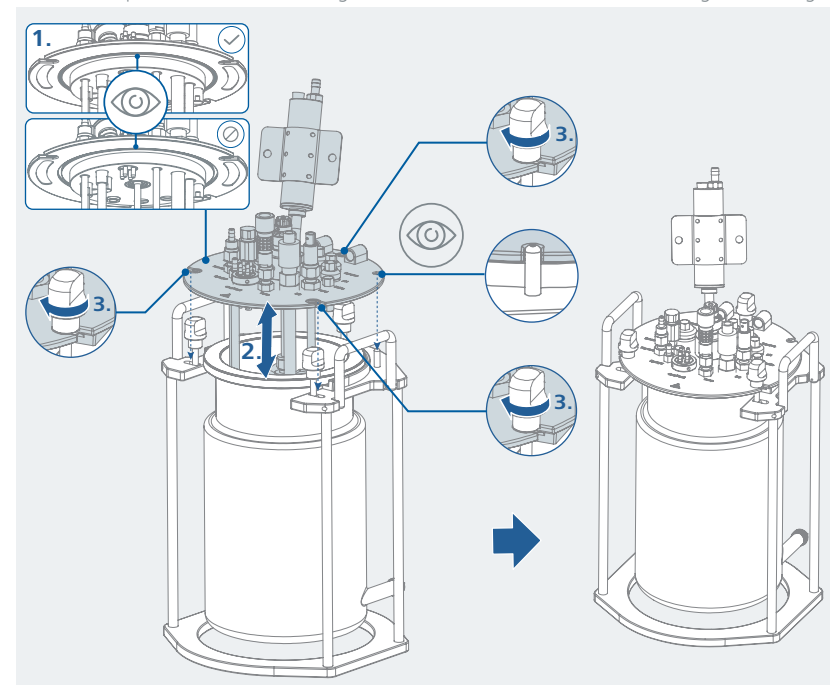

### /// Peltier cooling

#### ⚠ Notice!

> The Peltier cooling may only be used in conjunction with the IKA HABITAT.

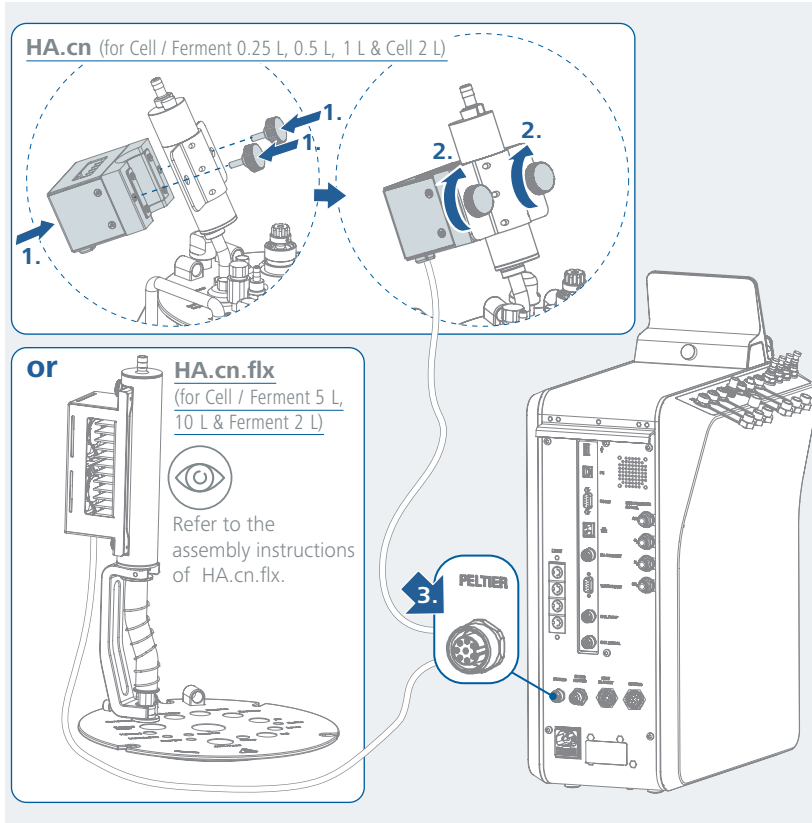

### /// Motor

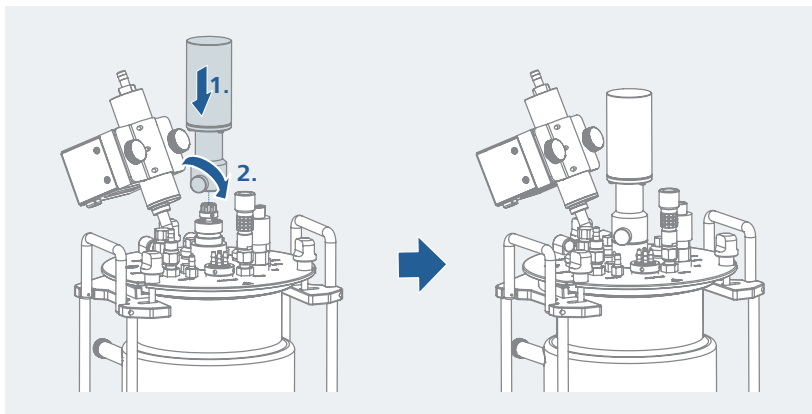

### /// Foam sensor

- > Blue LED ON: Good alignment between sensor boxes, and no foam present.
- > Blue LED OFF: Poor alignment between sensor boxes, or with obstructions in LED field of view.

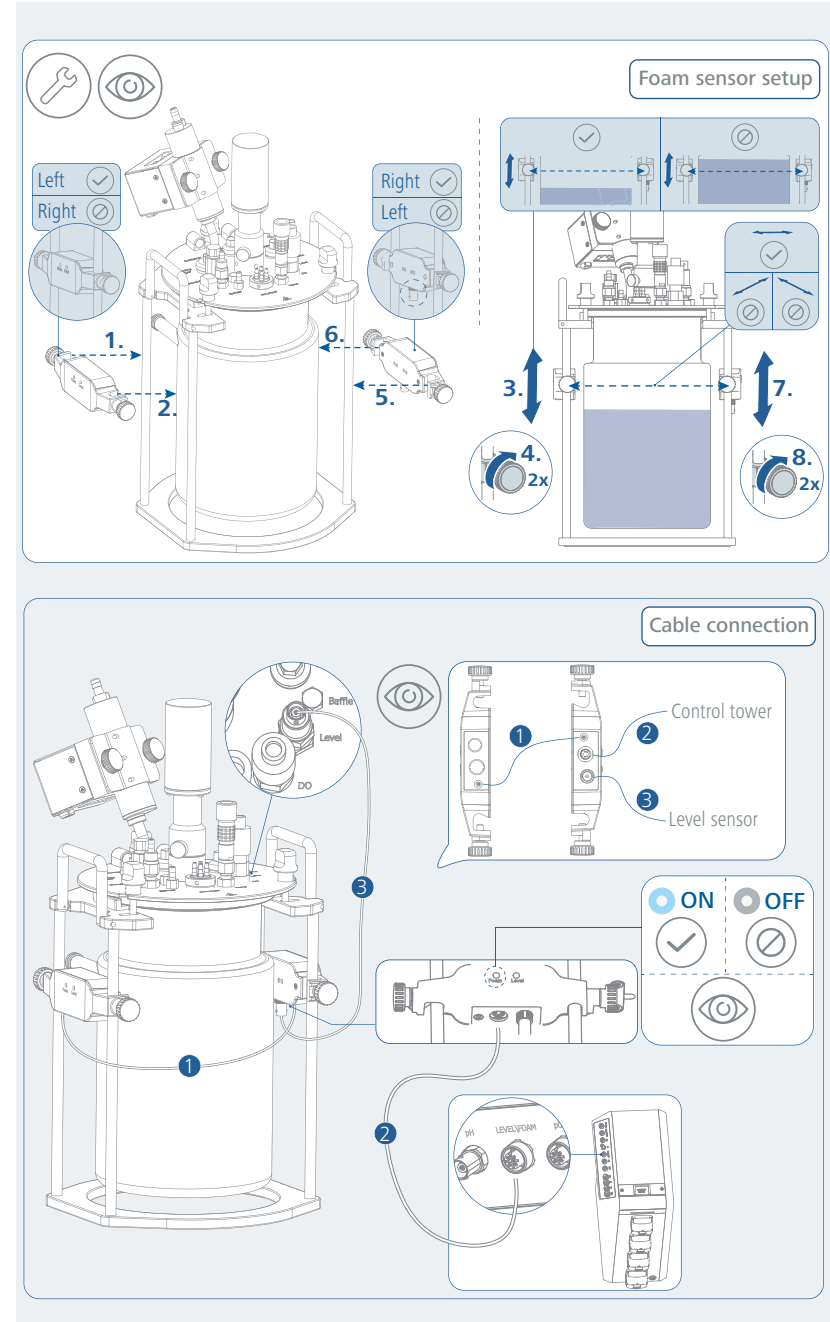

### /// Heat blanket

#### ⚠ Warning!

- > Ensure that the electrical equipment is in good condition before use.
- > For a long service life: Do not cut or fold!
- > Store the heat blanket in a flat condition.
- > Only for the use with single-walled reactor vessels!

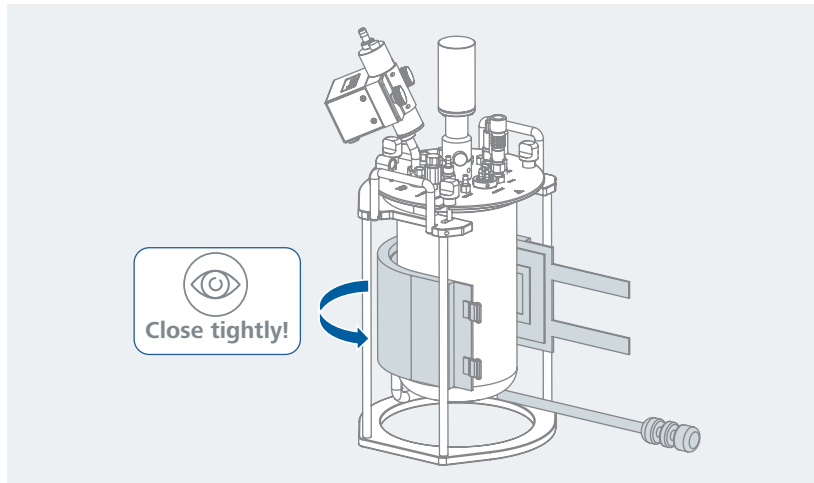

### /// Twist tie

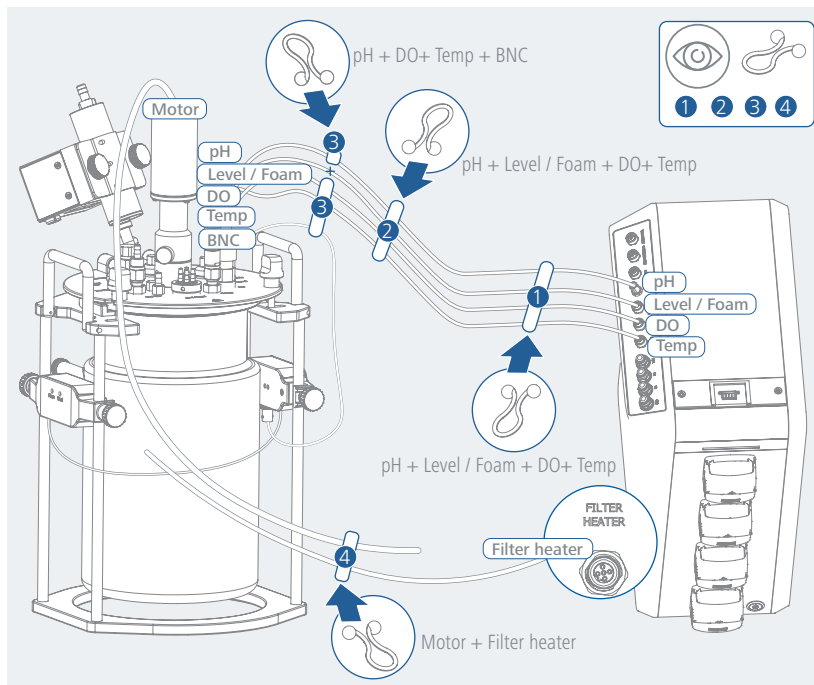

### /// Pump tubing

#### > Flow rate

Tube ID	Flow rate (cc/min)		Pump head adjustment
	min.	max.	
0.5 mm	0.3	4	A
0.8 mm	1.0	12	A
1.2 mm	1.6	20	A
1.6 mm	3.0	45	A
2.4 mm	7.0	85	B
3.2 mm	13.3	140	B
4.8 mm	26.6	270	B

#### > Adjust the pump head

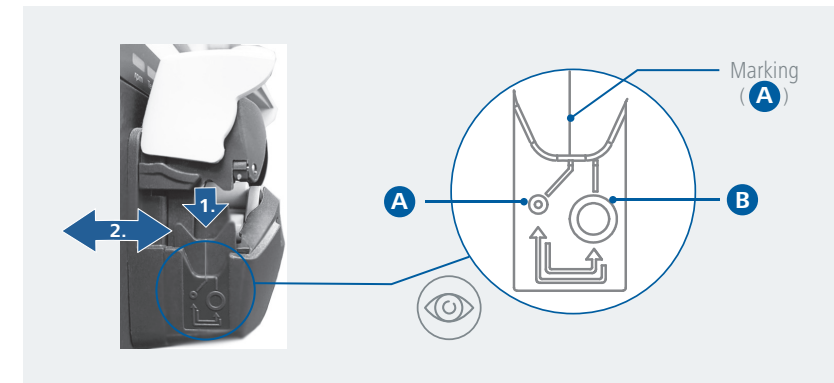

#### > Insert the tube to the pump head



### /// HA.ep External peristaltic pump (accessories)

> Refer to the operating instructions of HA.ep.

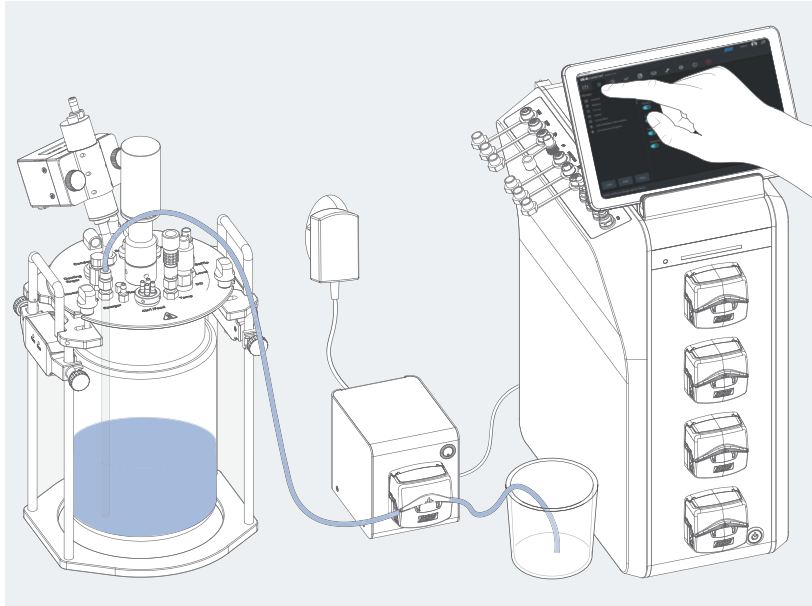

### /// Hose connecting

> Keep the hose connection as short as possible.

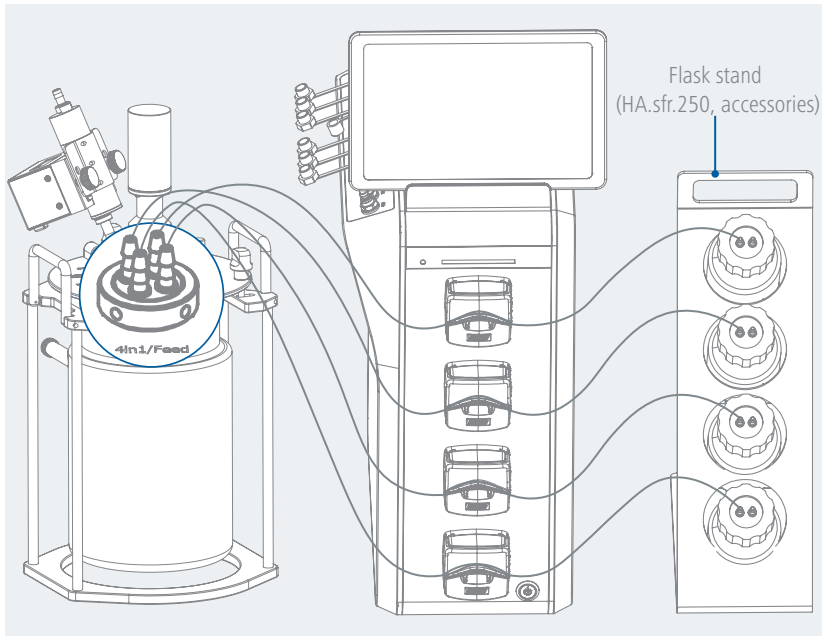

### /// Connecting gas outlet to sparger

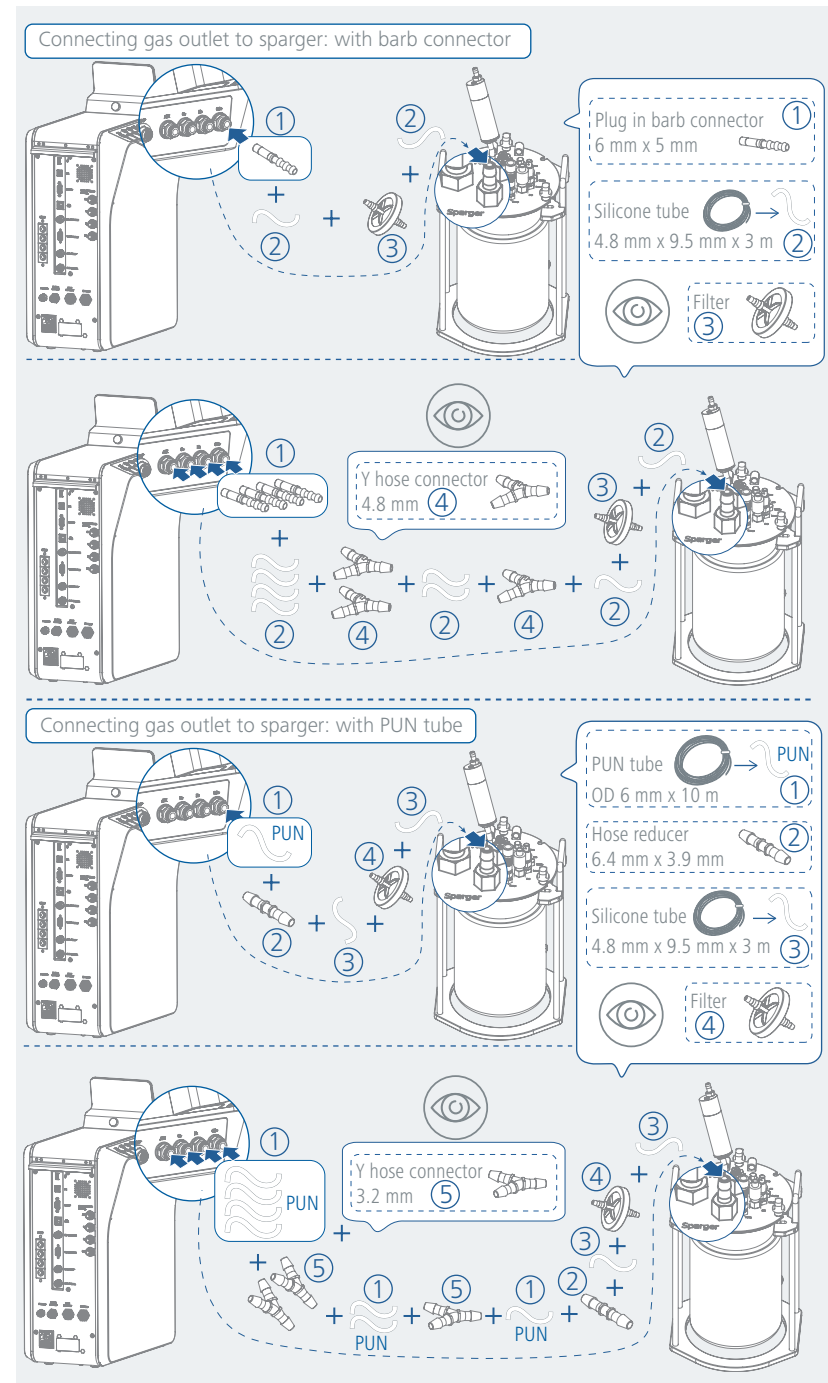

### /// Schematic view - 4 gases system

Abbreviation	Description	Abbreviation	Description
FS	Flow Sensor	pH	pH Sensor
CV	Check Valve	Level	Level Sensor
FVC	Flow Control Valve	Temp	Temperature Sensor
PRV	Pressure Relief Valve	CO <sub>2</sub> *	CO <sub>2</sub> Sensor
F	Filter	Cond*	Conductivity Sensor
FM	Foam Sensor	Turb*	Turbidity Sensor
HBL	Heat Blanket	FH	Filter Heater
pO <sub>2</sub>	DO Sensor		

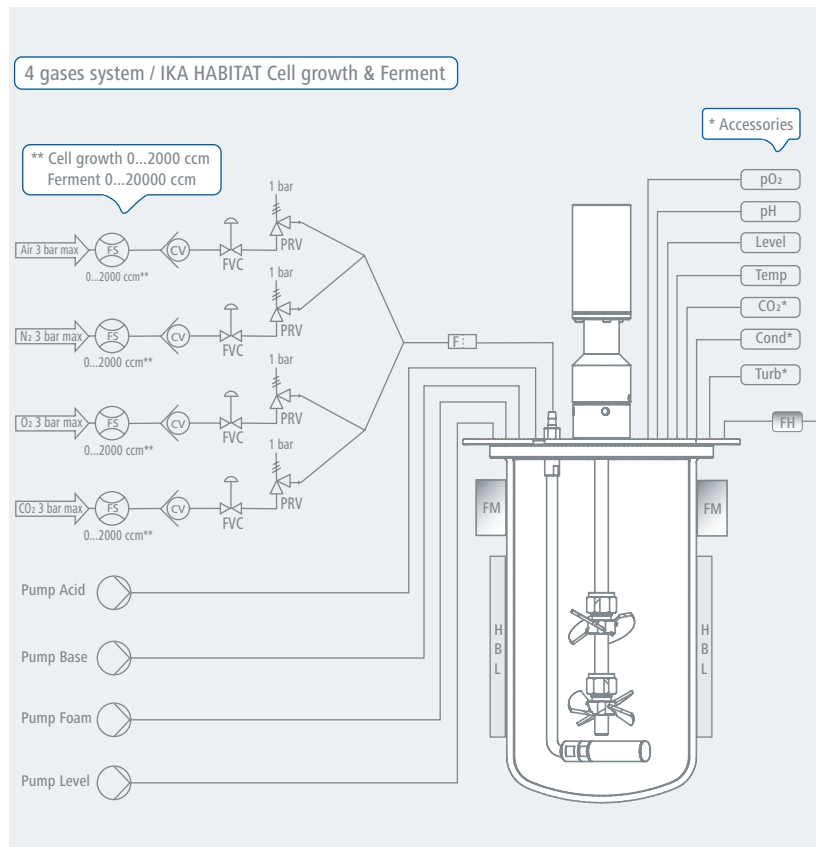

### /// Lid stand (accessories)

> Refer to the operating instructions of HA.Is.2 and HA.Is.10 plus.

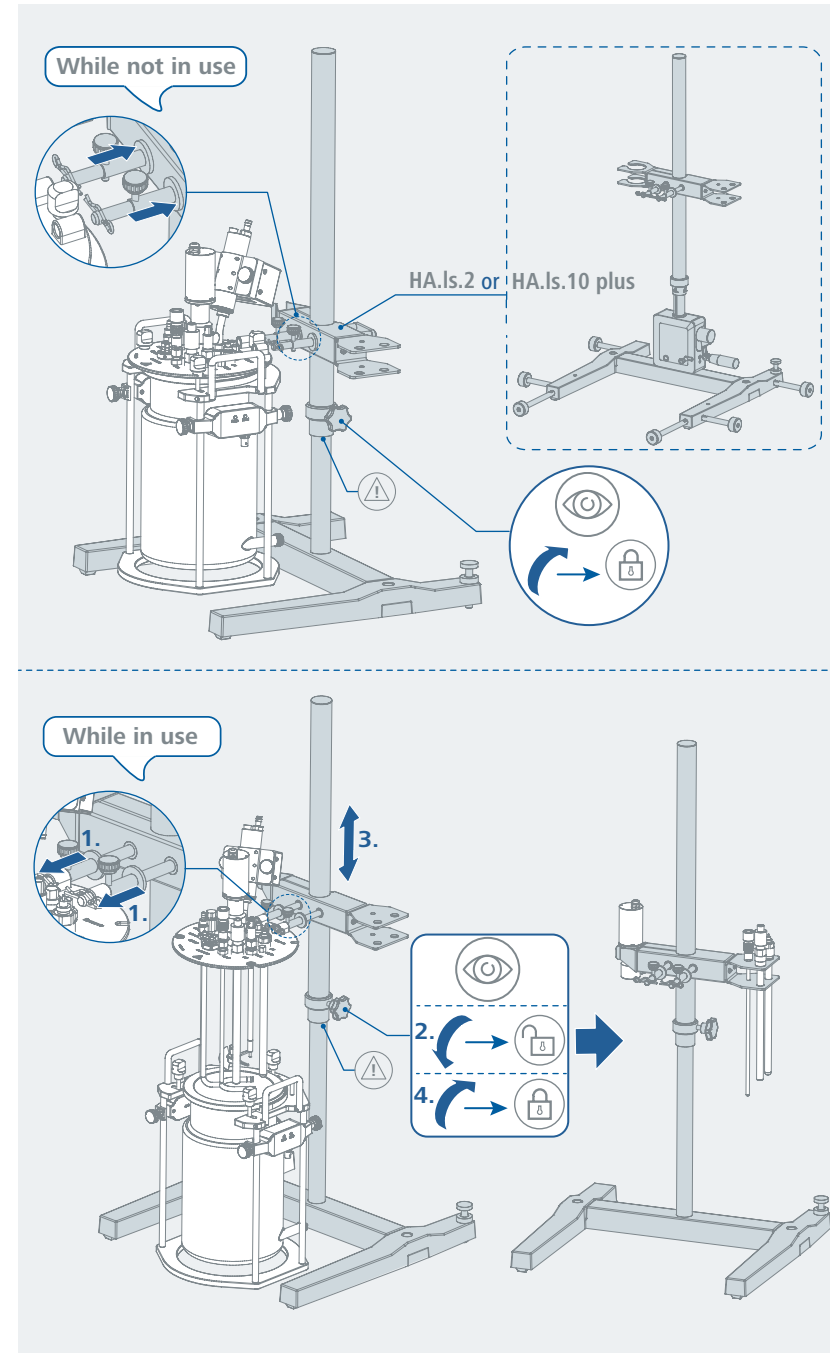



# Operation

## /// Switching on / off

1. Turn on the device by using the mains switch on the control unit.
2. Start tablet PC / laptop Bioreactor App.
3. Connect tablet PC / laptop via Ethernet, Wi-Fi® or Serial port.

## /// HABITAT "Quick start Guide"

### 1. iOS Installation

#### 1.1 iPad Setup

- › Set up your device for the first time or after having done a factory reset.
- › For the setup of the iOS device (Apple iPad) please refer to the device setup information from Apple Inc.

#### 1.2 Installing the HABITAT app

- › Go to the App Store and search for "IKA HABITAT" or scan the QR code below to install the app.

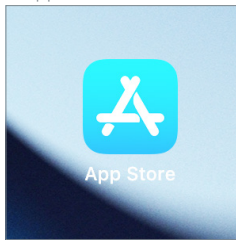

App Store

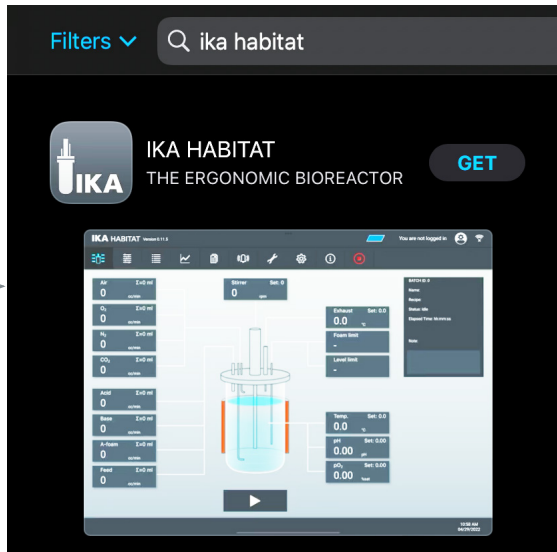

- › Click the link on your iOS device to install IKA HABITAT app (<https://apps.apple.com/us/app/ika-habitat/id1579608969>)



QR code

#### 1.3 Updating the application / app

- › If an update of the IKA HABITAT app is available in the App Store, you will be notified.  
**Note:** If the IKA HABITAT app was installed by a previous user or already in the delivery state, the app must first be uninstalled and reloaded when changing accounts.

## 2. Getting start

### 2.1 Initial commissioning and setup

- › First, turn on the IKA HABITAT, make sure that the device is ready for operation (all LEDs: green) and connected to the computer / Tablet PC via Wi-Fi® or Serial connection / USB cable.
- 2.1.1 Connecting to the device (See "HABITAT Software connect Guide")

### 2.2 Logging in

- › After initialization and synchronization between the operating software and the control unit, the opening screen shows the process view (main screen with reactor vessel and all process parameters and status).
- › The user must log in to operate the device. The default user name and password is "admin". The password can be changed after the first login.

### 2.3 Setting the set points

- › After clicking on a parameter values window, a submenu for setup and control settings appears.

#### 2.3.1 Operating mode

- › The user can select and set the operating mode for each component / controller:
  - Off: Component / controller is off.
  - Manual: Component / controller operates according to the user's setpoint settings.
  - Automatic: Component / controller operates according to the control algorithms of the process conditions.
  - Profile: Component / controller operates according to predefined set points.

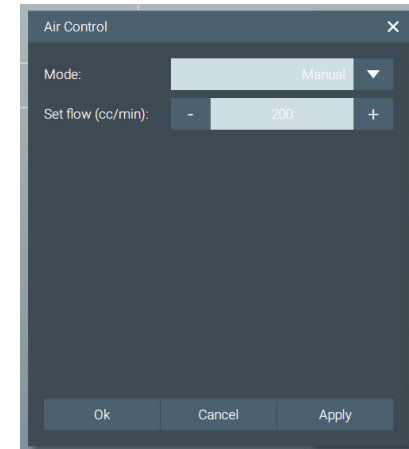

### 2.4 Changing "User ID" and "Password"

- › Log in.
- › Click the icon "User" and then the submenu "User Management".
- › In the "User Management" menu, click "Edit user", and then enter your new password.

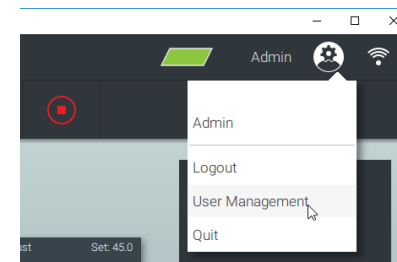

### 2.5 Time synchronization

- › After clicking the menu "Device time", a submenu opens with a confirmation dialog for time synchronization between the Tablet/PC and the control unit.

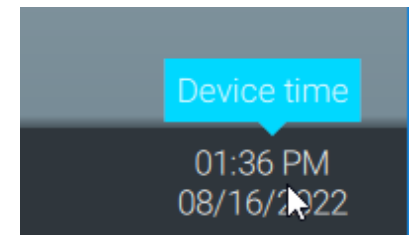

### 2.6 Exit the application

- › Click on the icon "User" followed by "Quit".

## // HABITAT "Software connect Guide"

### 1. Software connection (Windows version)

#### 1.1 Components

- > HABITAT control unit
- > Laptop / PC with HABITAT software installed
- > Cable (USB, RS-232, LAN) or Wireless (Wi-Fi®) connection

#### 1.2 Connection (4 options)

##### 1.2.1 USB cable connection

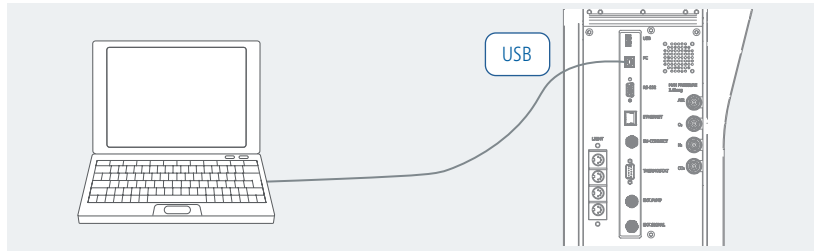

- > Open the IKA HABITAT software and select "Scan for new Device".
  - The software shows the available devices detected from the serial port.
  - Click "Connect" to start the connection.

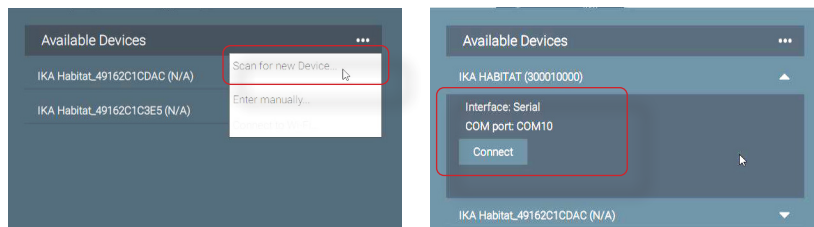

##### 1.2.2 RS-232 cable connection

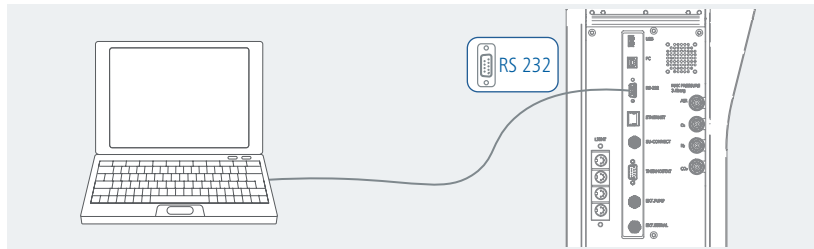

- > Open the IKA HABITAT software and select "Scan for new Device".
  - The software shows the available devices detected from the COM port.
  - Click "Connect" to start the connection.

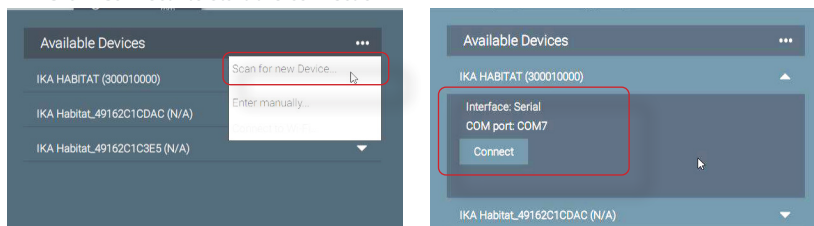

- After data synchronization, the icon "Cable connection" is displayed.

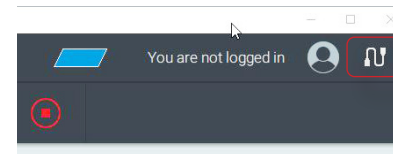

##### 1.2.3 Ethernet / LAN cable connection

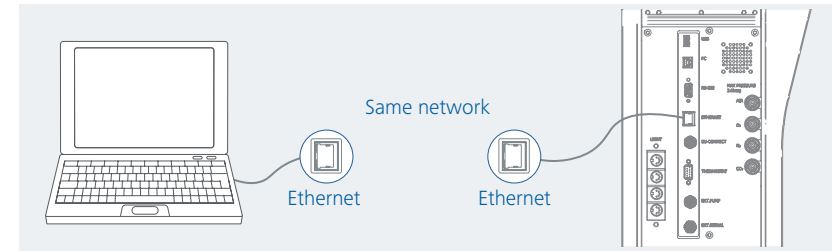

- > Open the IKA HABITAT software and select "Scan for new Device".
  - The software shows the available devices detected from the Ethernet port.
  - Click "Connect" to start the connection.

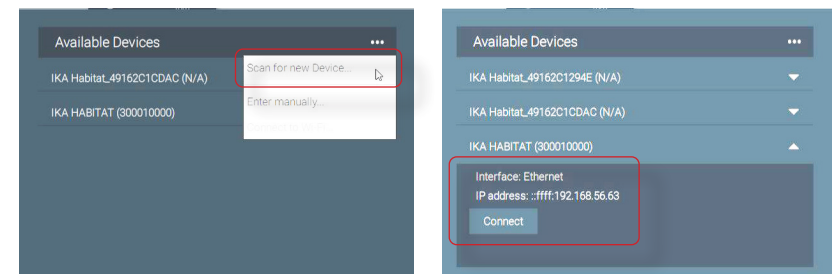

- After data synchronization, the icon "LAN cable connection" is displayed.

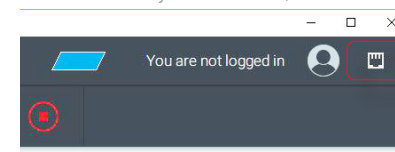

##### 1.2.4 Wi-Fi® connection

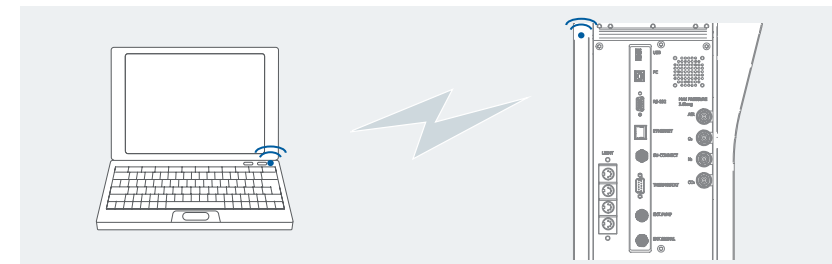

- › Open the IKA HABITAT software and select "Scan for new Device".
  - The software shows the available devices detected from the Wi-Fi® SSID: **IKA\_HABITAT\_XXXXXXXX**
  - Click "Connect" and enter the Wi-Fi® password "**ikahabitat**" (only necessary for the first connection) to start the connection.

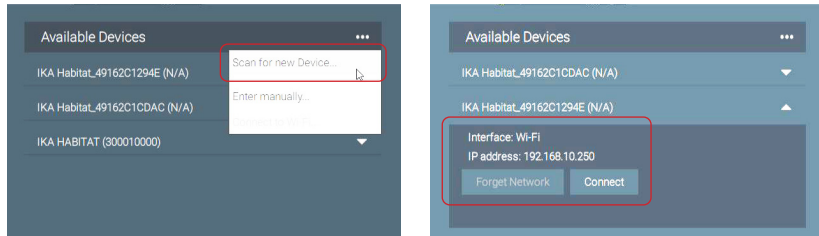

- After data synchronization, the icon "Wi-Fi® connection" is displayed.

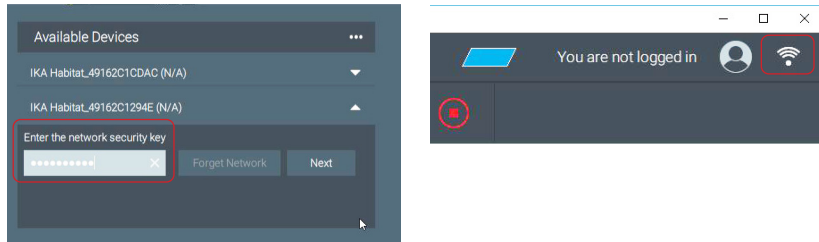

## 2. App connection (iOS version)

### 2.1 Components

- › HABITAT control unit
- › iPad with HABITAT App installed (download from App store)
- › Wi-Fi® connection

### 2.2 Connection

Wi-Fi® connection from iPad to the control unit

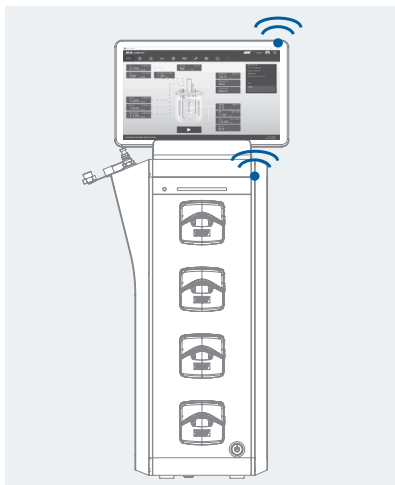

- › Enter the password "**000000**" (default password for logging in).
- › Open the IKA HABITAT App and select "Connect to Wi-Fi®...".

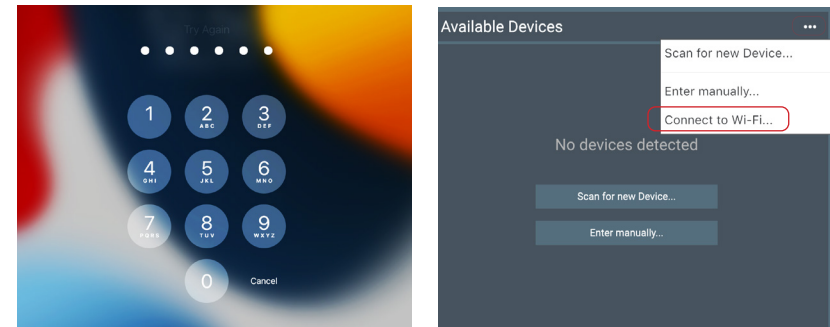

- › Select "Wi-Fi®" setting.

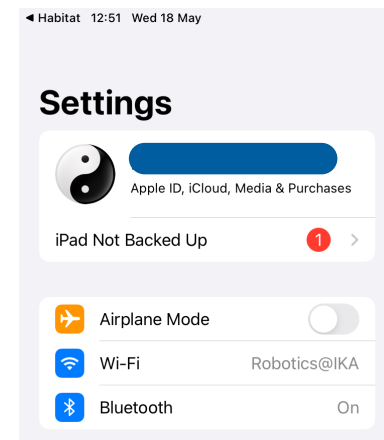

- › Connect to the HABITAT control unit via Wi-Fi® SSID: **IKA\_HABITAT\_XXXXXXXX-**
- Enter the password "**ikahabitat**" (only necessary for the first connection) to start the connection.

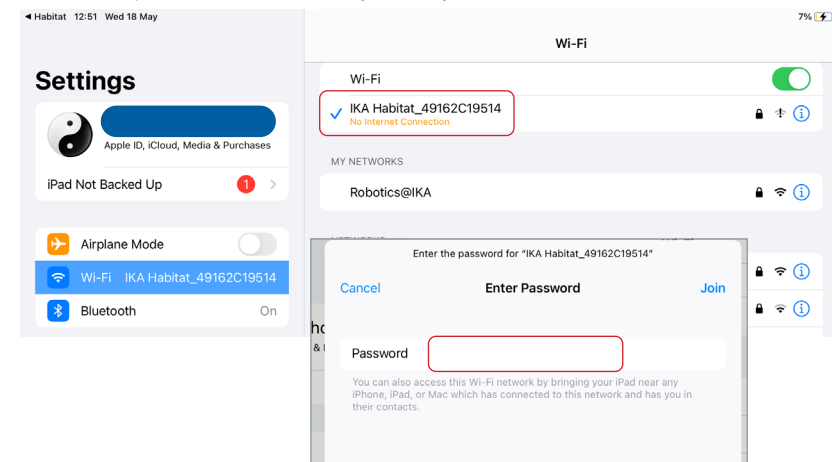

> Click to return to the IKA HABITAT App.

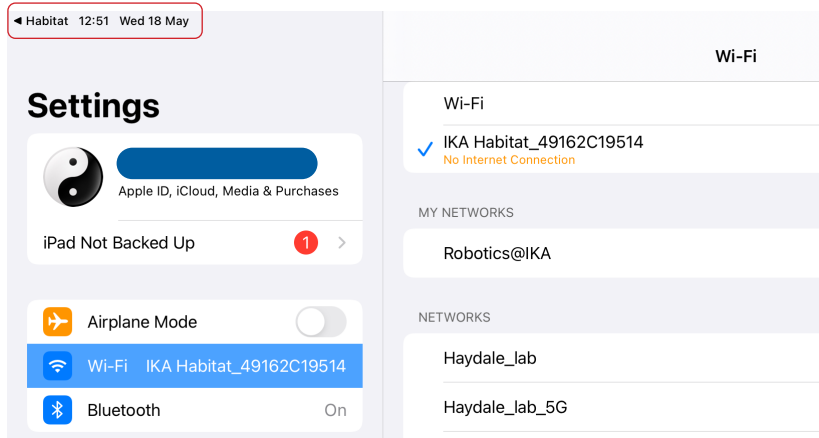

> Select "Scan for new Device".

- The software shows the available devices detected from Wi-Fi®.
- Click "Connect" to start the connection.



- After data synchronization, the icon "Wi-Fi®" connection" is displayed.

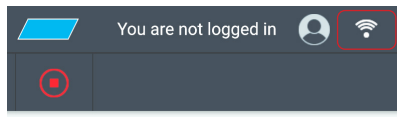

### IMPORTANT NOTE!

- **Disable** "Auto-join" for Wi-Fi® connection to other devices to establish a stable connection between iPad and Control Unit.

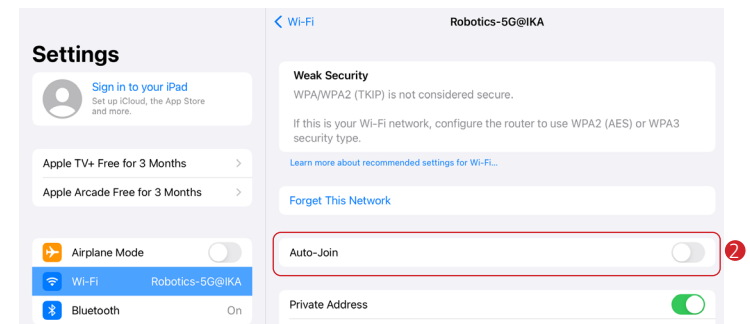
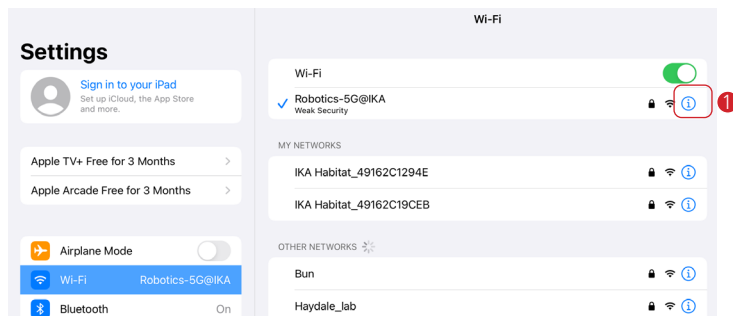

- **Enable** the "Auto-join" only for pairing with the controller unit to establish a stable connection between iPad and control unit.

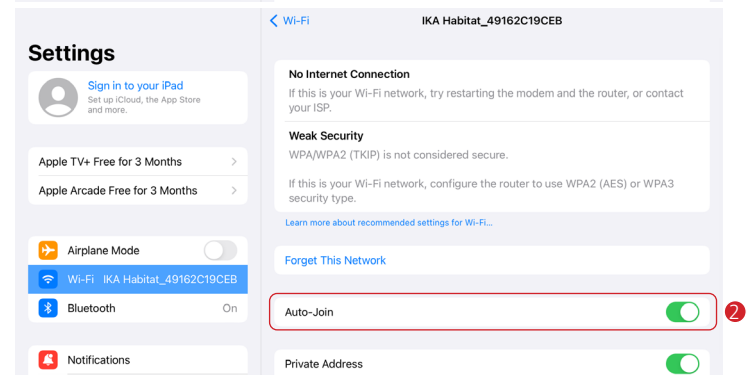
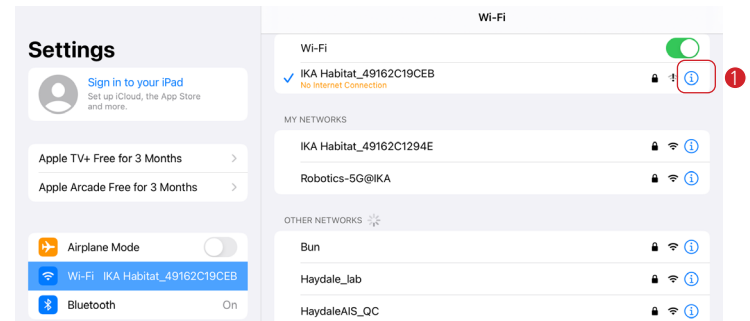

### 2.3 iPad cable connection

- › Backup solution for cable connection from iPad to the control unit

### 2.31 Components

- ① USB-C to Ethernet Adapter (with the charging port)
- ② LAN cable

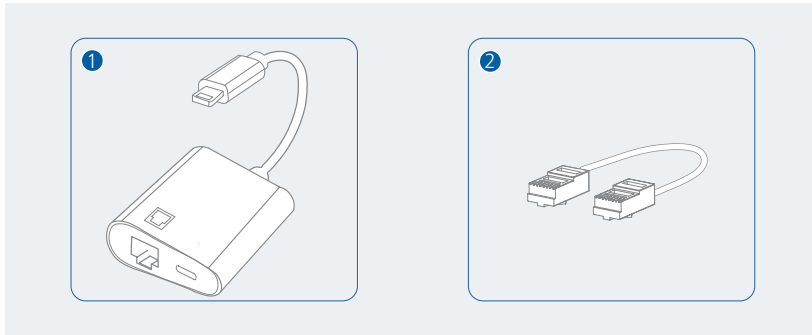

### 2.32 Connection

- › Connect the iPad to the Ethernet Adapter.
- › Connect the charging port of the control unit to the "USB-C" port of the Ethernet Adapter.
- › Connect the Ethernet port of the control unit to the "Ethernet" port of the Ethernet Adapter.

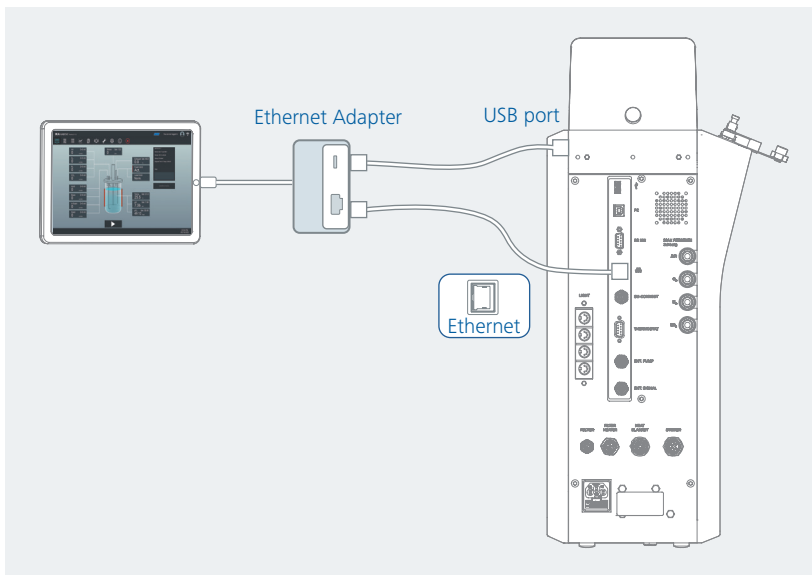

- › Set Ethernet connection for iPad (one-time setting):

- ① Select "<...> Ethernet"
- ② Select "USB 10/100 LAN"

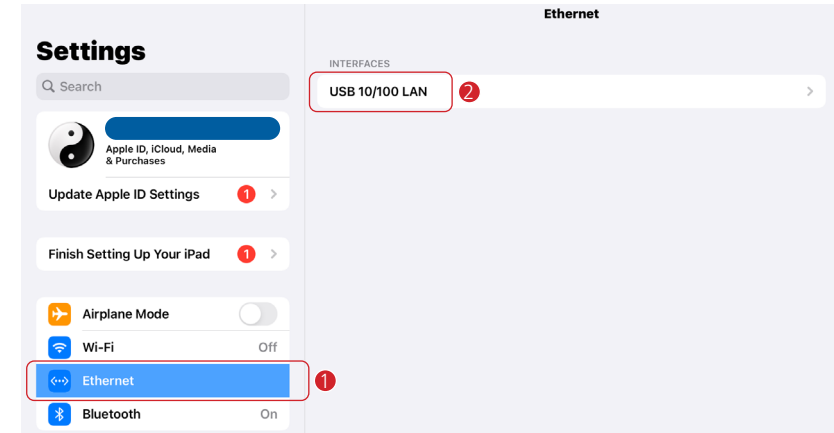

- ③ Select "Configure IP"

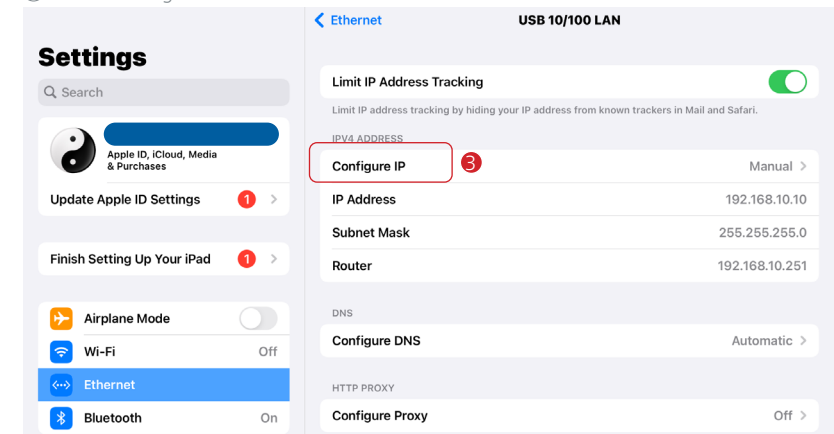

- ④ Select "Manual"
- ⑤ Set the IP Address / Subnet Mask / Router:  
IP Address: **192.168.10.10**  
Subnet Mask: **255.255.255.0**  
Router: **192.168.10.251**
- ⑥ "Save" the setting

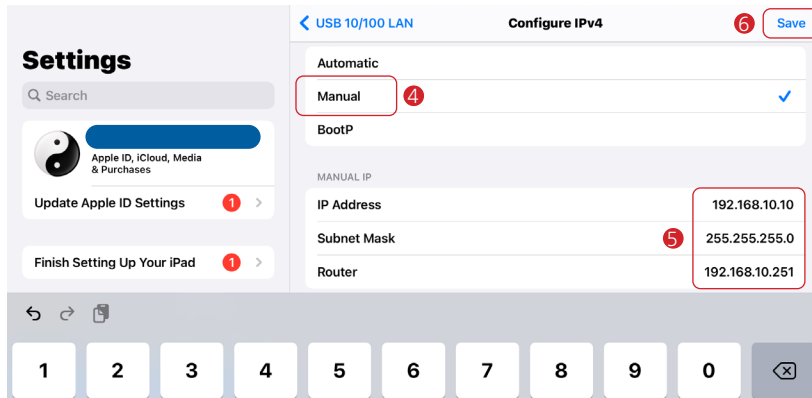

› HABITAT software connect

- ① Open HABITAT software
- ② Select "." at "Device Connection"
- ③ Select "Enter manually"
- ④ Select communication type as "Ethernet"
- ⑤ Define host name as "**192.168.10.251**"
- ⑥ Define port as "**40999**"
- ⑦ Then, click "Connect"  
- After data synchronization, the icon "Ethernet connection" is displayed.

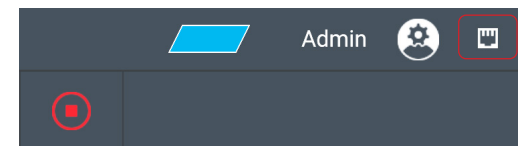
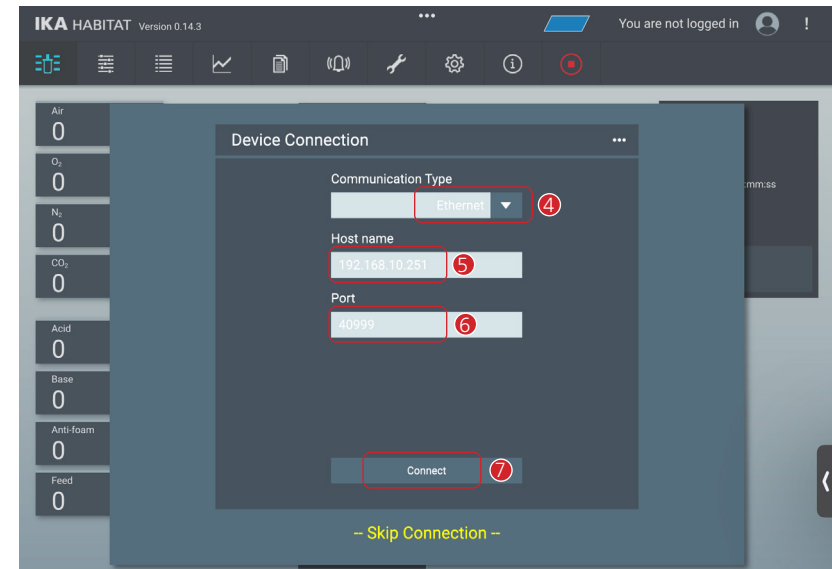
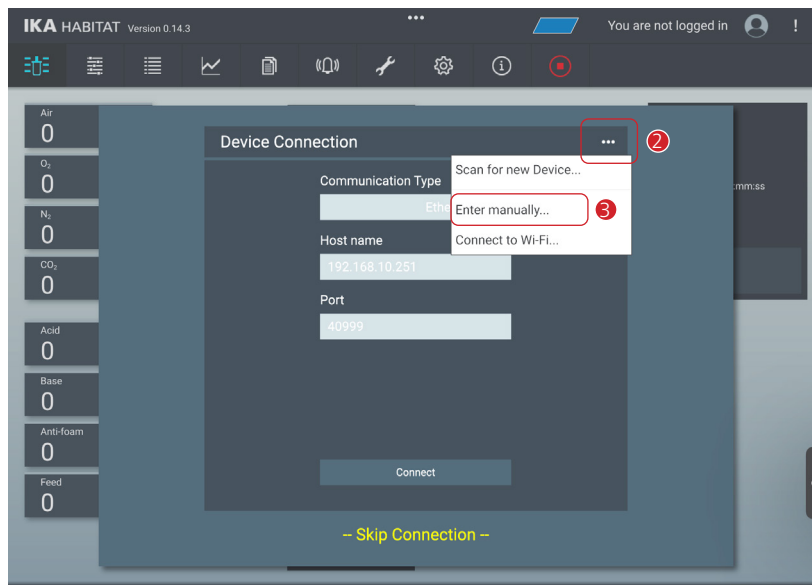

3. HABITAT App connect (Android version)

3.1 Components

- › HABITAT control unit
- › Android Tablet with HABITAT App installed (download from Play store)
- › Wi-Fi® connection

3.2 Connection

Wi-Fi® connection from Tablet to the control unit

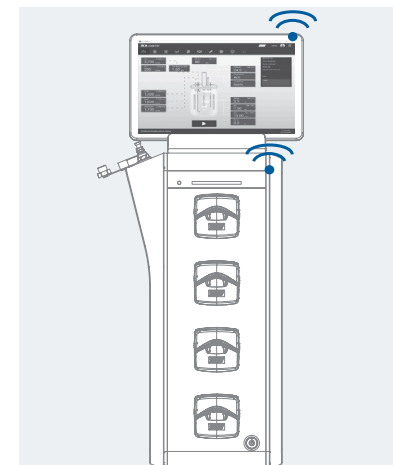

› Open HABITAT App, and select "Connect to Wi-Fi®...".

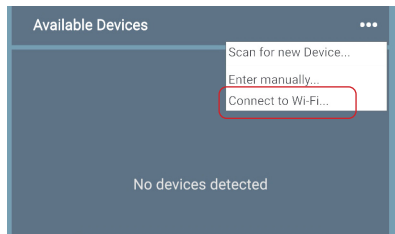

- › Connect to the HABITAT control unit via Wi-Fi® SSID: **IKA\_HABITAT\_XXXXXXX**
  - Enter the password "**ikahabitat**" (only necessary for the first connection) to start the connection.
  - Recommend to select "Always connect" (only necessary for the first connection).

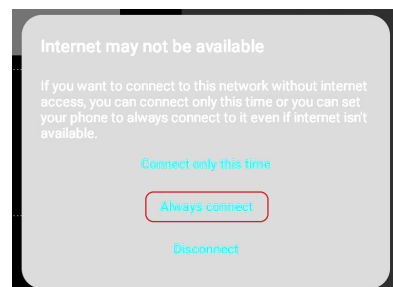
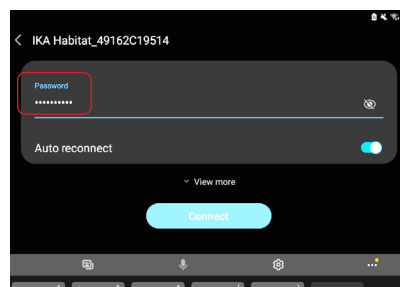
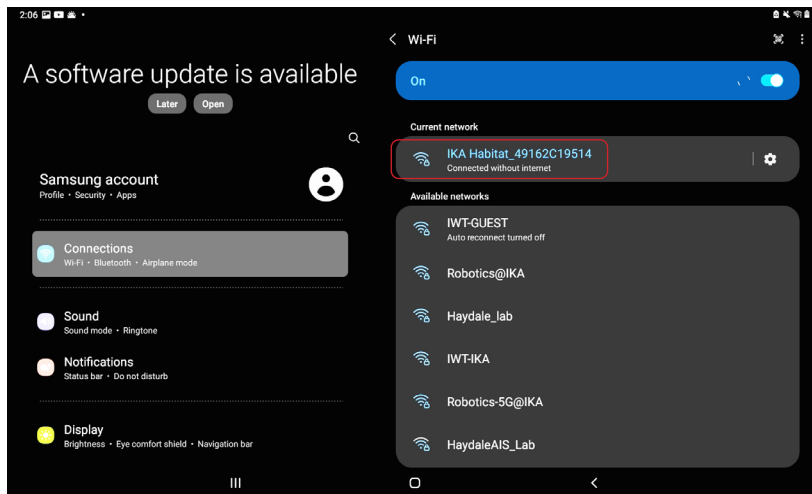

› Click to return to the IKA HABITAT App.

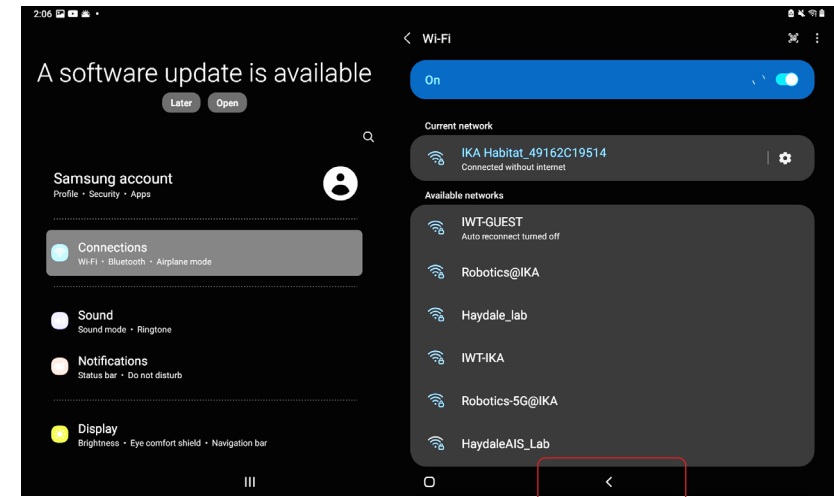

- › Select "Scan for new Device...".
  - The software shows the available devices detected from Wi-Fi®.
  - Click "Connect" to start the connection.

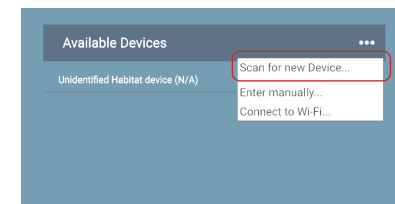

- After data synchronization, the icon "Wi-Fi® connection" is displayed.

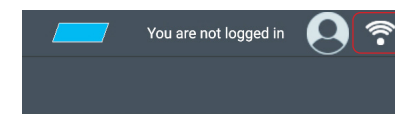

### IMPORTANT NOTE!

> **Disable** "Auto-join" for Wi-Fi® connection to other devices to establish a stable connection between Tablet and Control Unit.

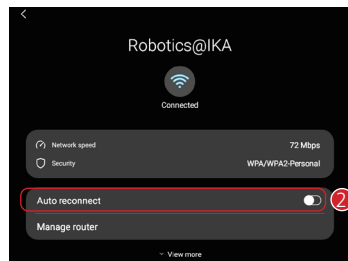
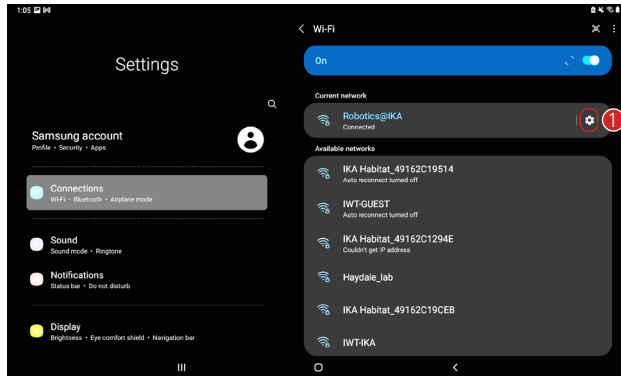

> **Enable** the "Auto-join" only for pairing with the controller unit to establish a stable connection between Tablet and Control Unit.

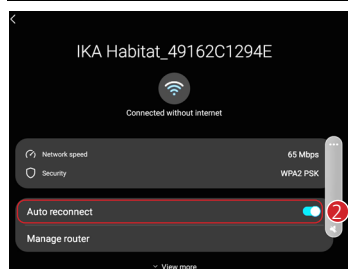
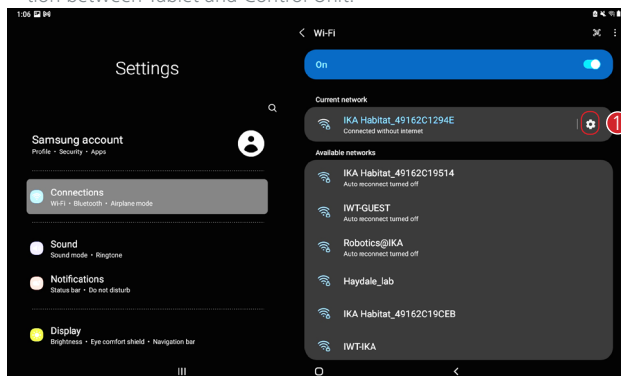

### /// Menu structure

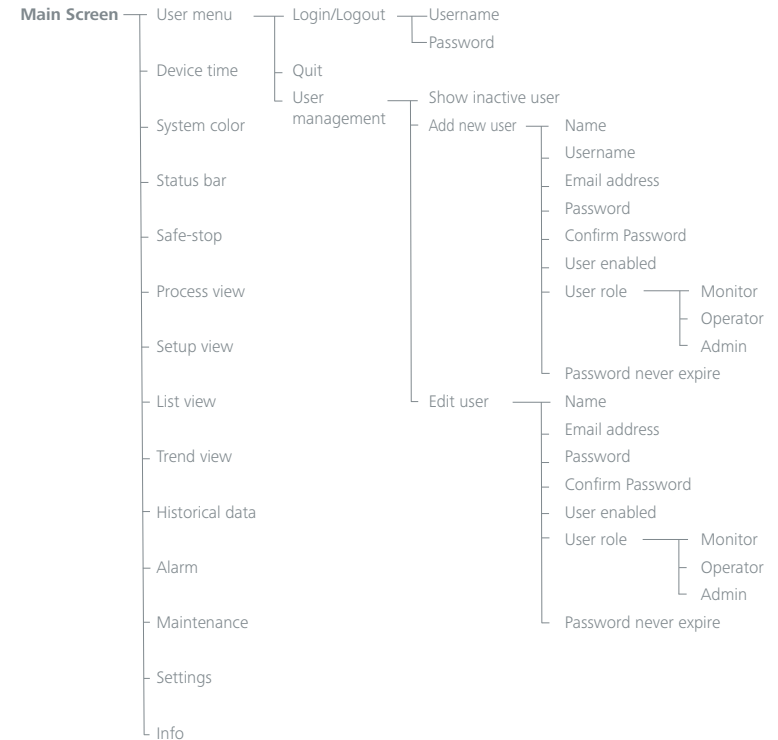
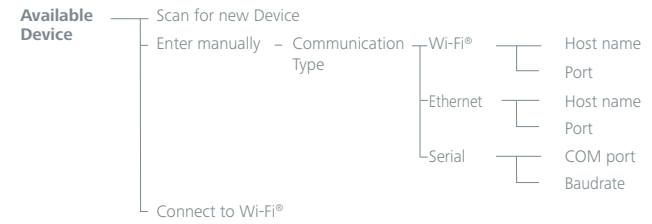

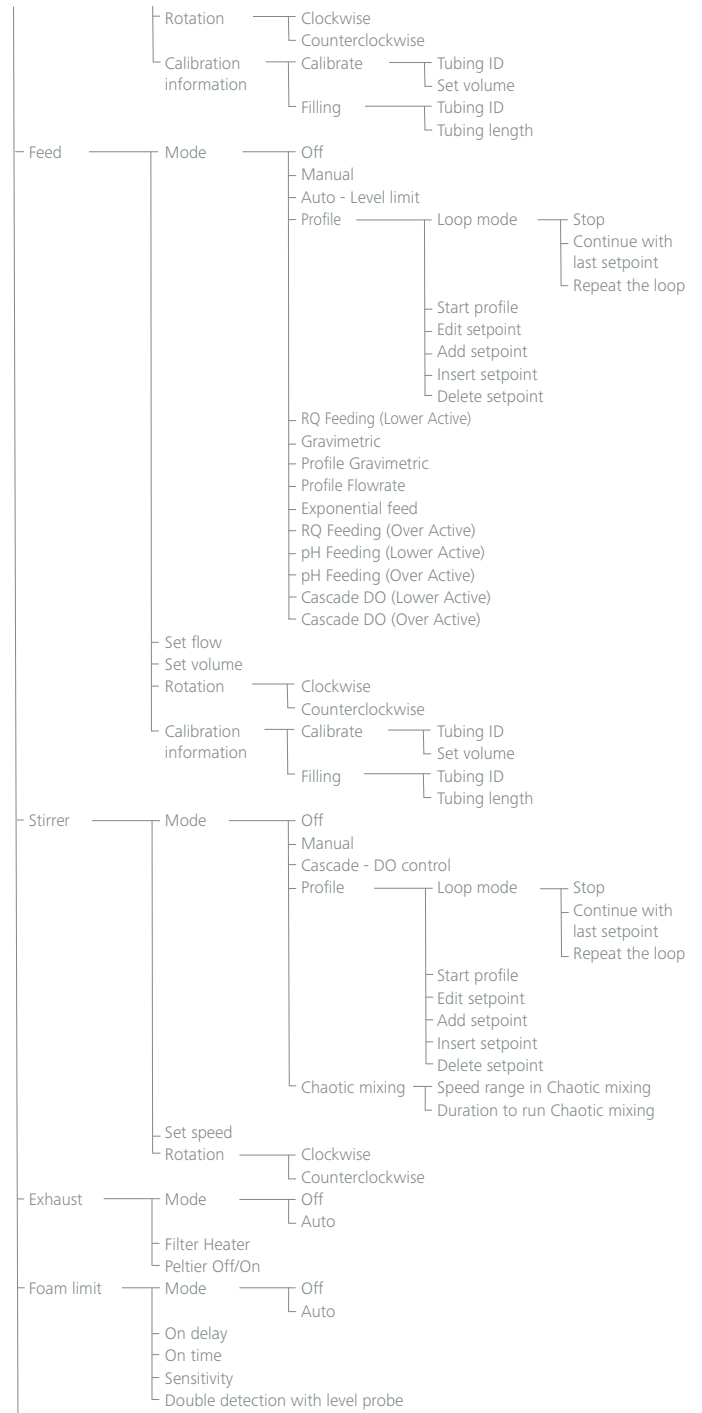
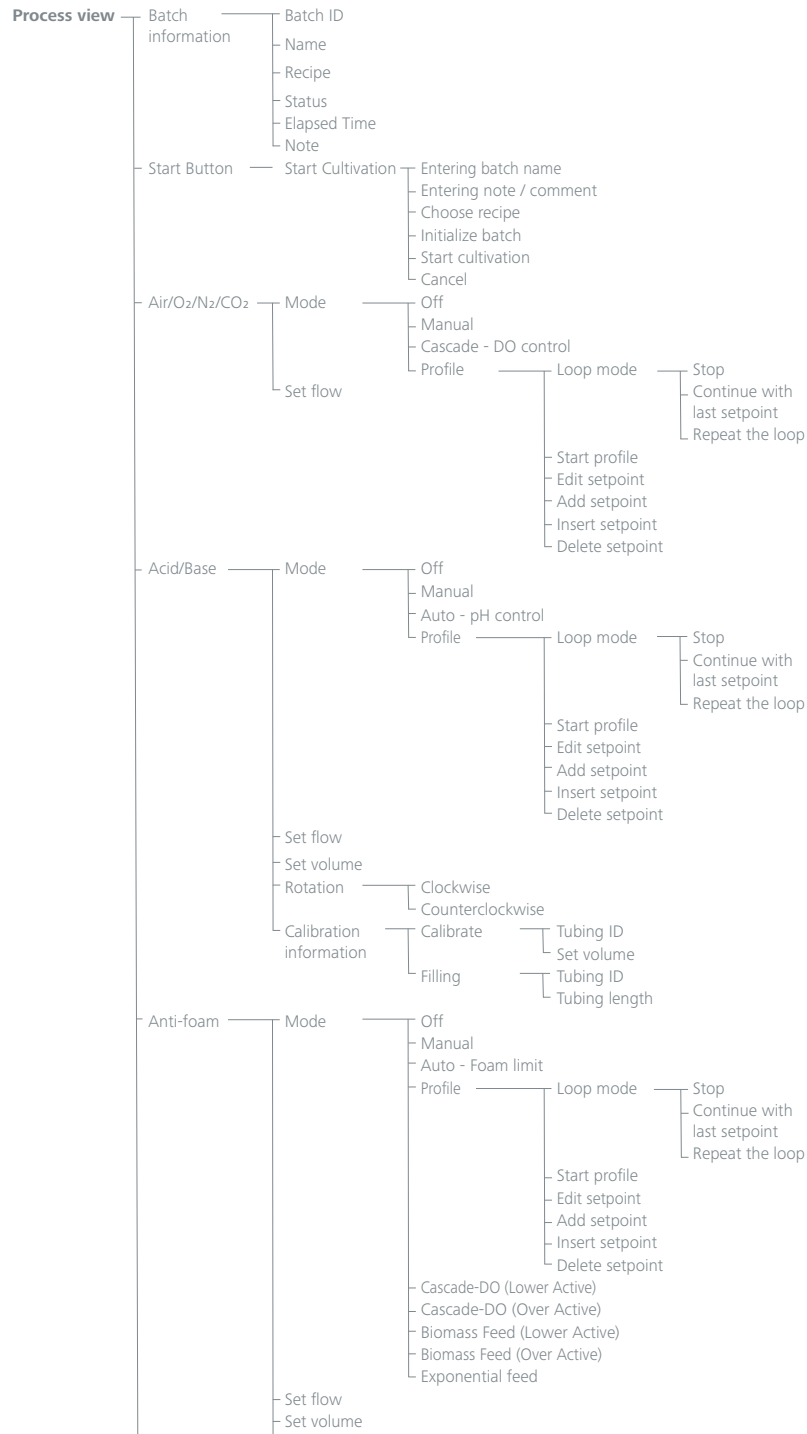

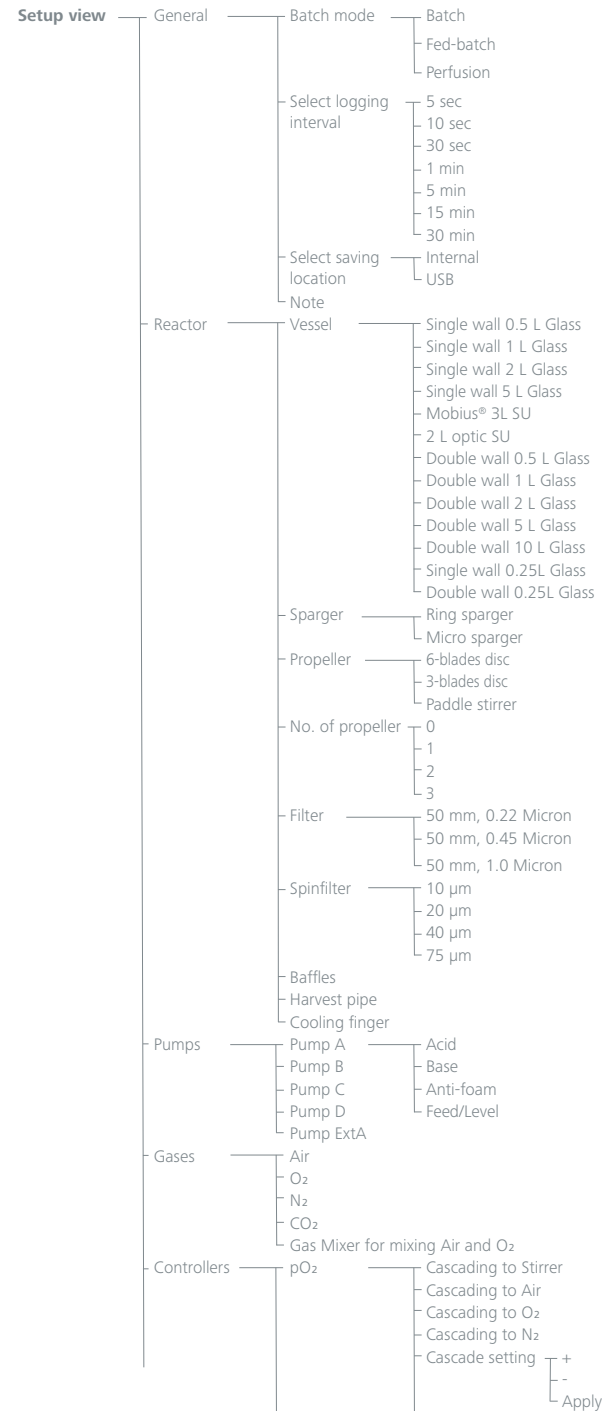
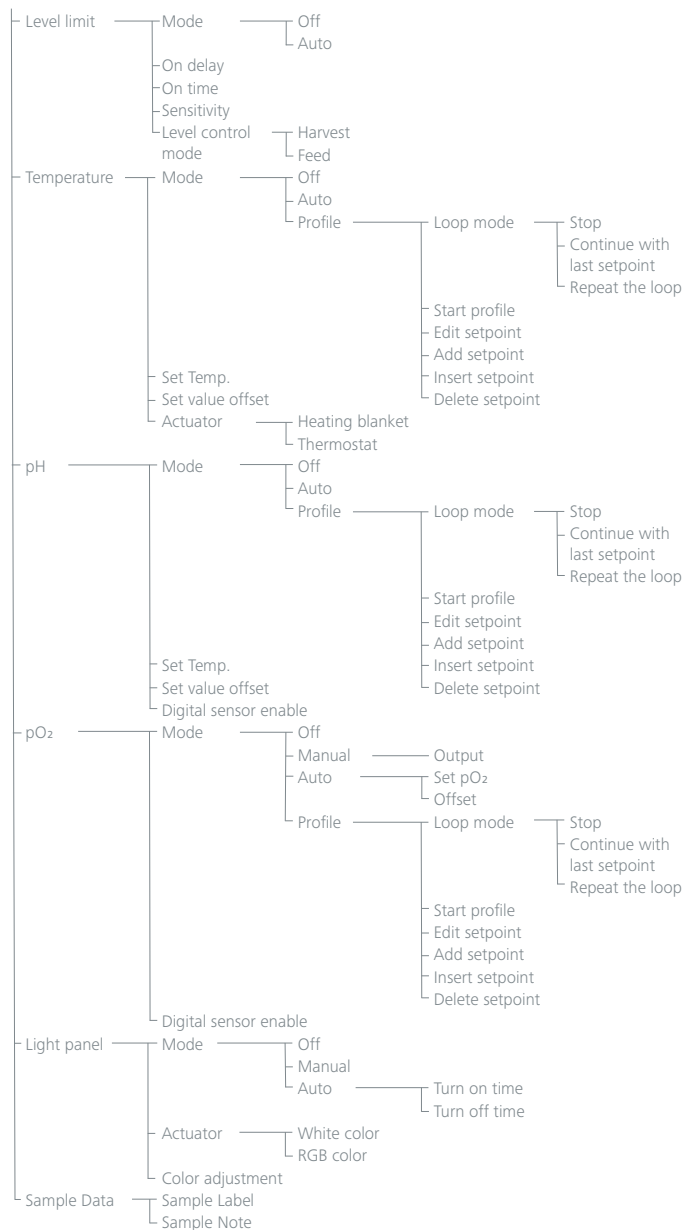

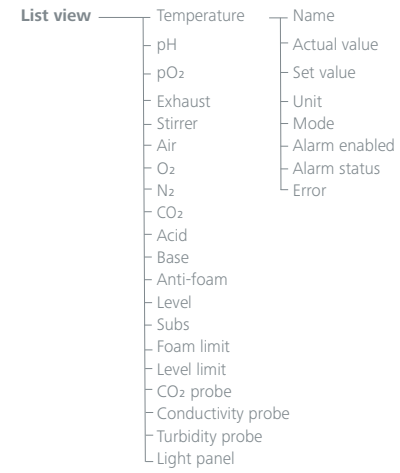
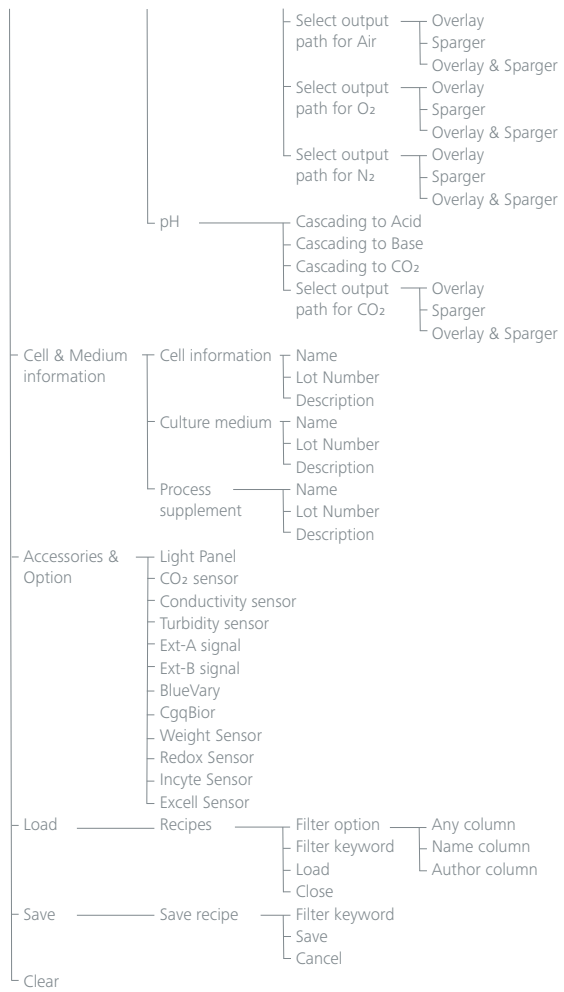

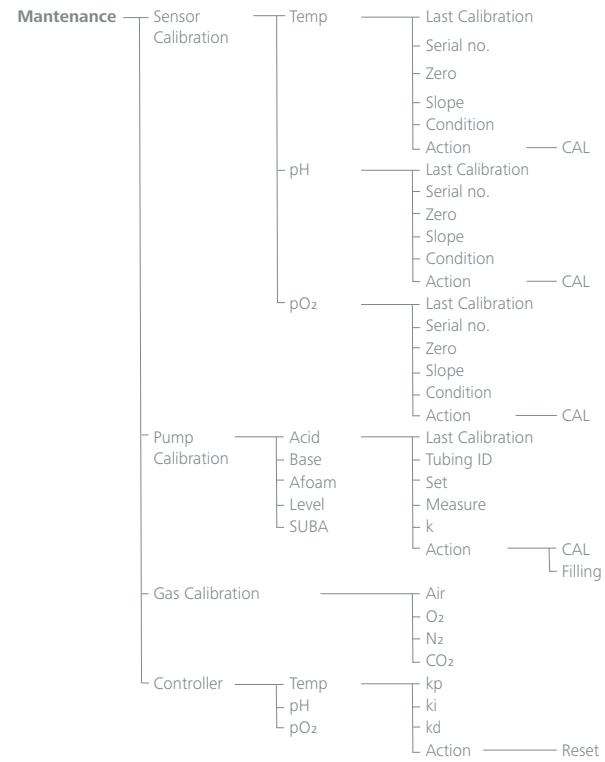
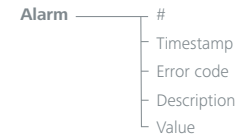
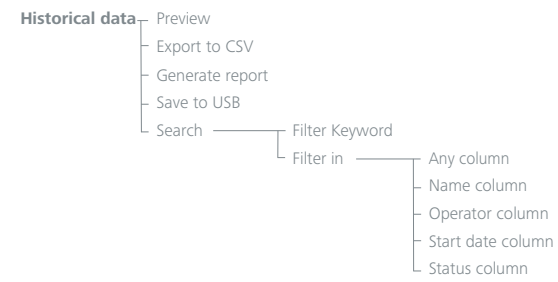

- Settings
  - General
    - Device Name
    - Language
      - System (system)
      - English (en\_US)
      - Deutsch (de\_DE)
      - 中文 (zh\_CN)
      - Español de españa (es\_ES)
      - Française (fr\_FR)
      - Italiano (it)
      - ไทย (th)
    - Select Mass flow unit
    - Down sampling Algorithm for Graph plotting
    - Auto restart after power failure
  - Alarm setting
    - Enable
    - Lo limit
    - Hi Limit
  - System
    - Factory default
    - Save setting
    - Upload setting
      - Database backup
      - Database restore
    - Device type
      - Not set
      - HABITAT Cell
      - HABITAT Ferment
      - HABITAT Cell Photo
      - HABITAT Ferment Photo
      - HABITAT Cell CCT
      - HABITAT Ferment CCT
      - HABITAT Cell Photo CCT
      - HABITAT Ferment Photo CCT
  - Logging level
    - Info
    - Debug
  - Log file to keep (days)
  - Peltier Driver
    - Internal
    - External
  - Pump Driver
    - Normal speed
    - Low speed
  - MFC version
    - V1.0
    - V2.0

- Info
  - About
    - Device information
    - Firmware information
    - GUI software information
    - Disclaimer
  - IKA Cloud
    - IKA Cloud Registration Information
    - Activate Cloud Communication
    - Go to: IKA Cloud
  - Manual
  - Video User guides
  - Shop

## /// Menu navigation

### 1. Screen Format

#### 1.1 Screen Layout Desktop / Tablet

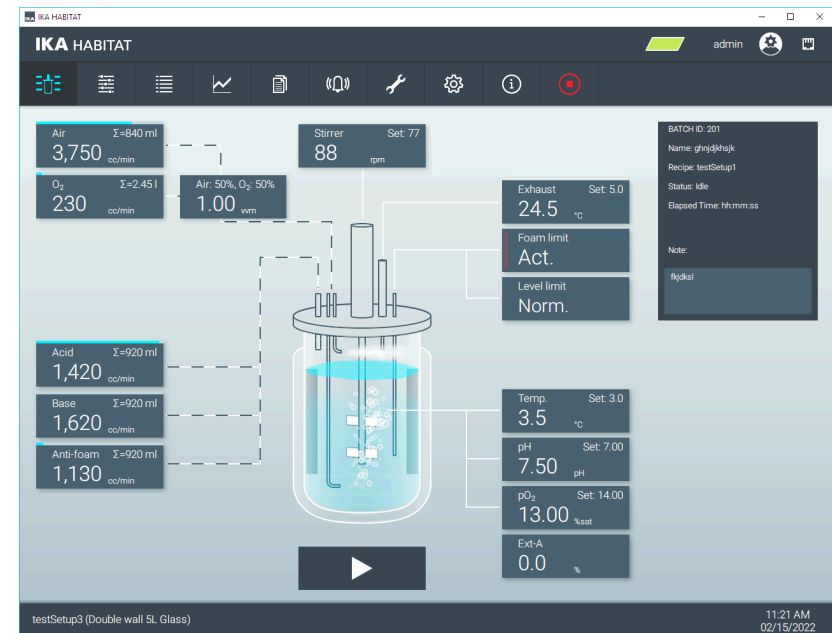
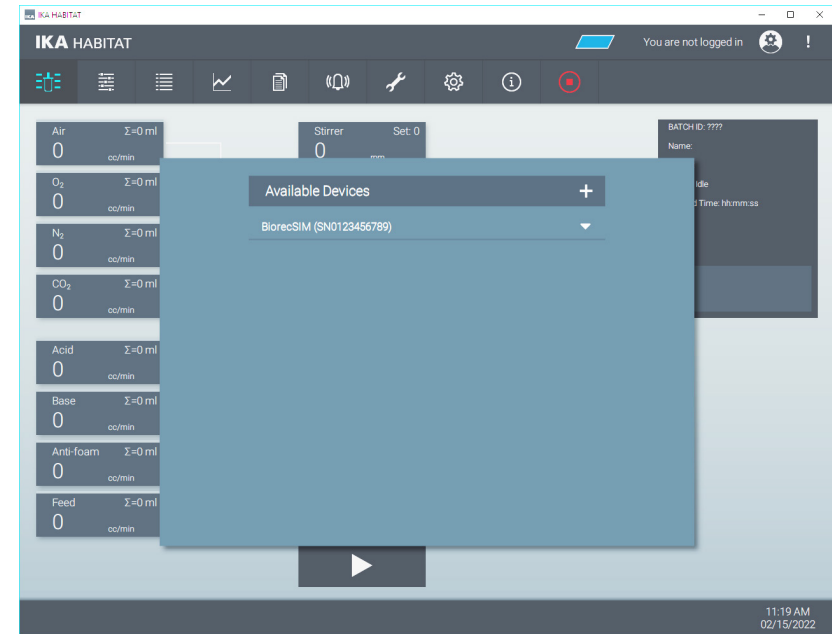

## 1.2 Screen Layout Mobile

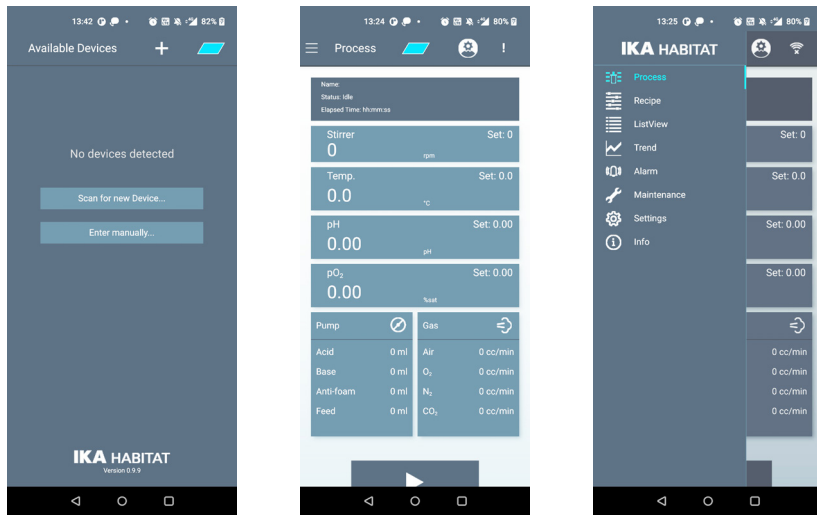

## 2. Screen List

### 2.1 Screen of all available devices

- To display all available devices that are discovered by the software via Networks (Ethernet, Wi-Fi® Serial port and WPAN).

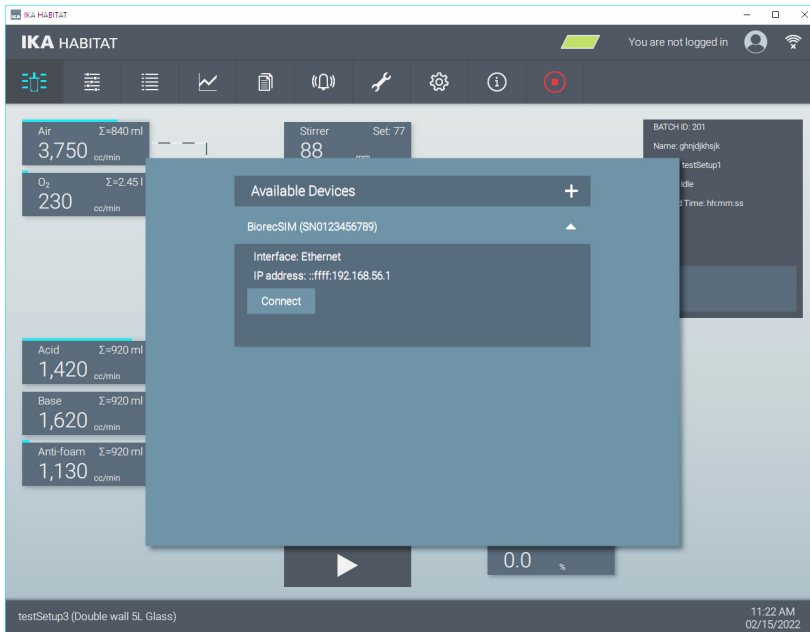

- Click on the plus sign "+" to open menu for re-scanning of new devices or entering the information to connect the device manually if it's not discovered by the software.

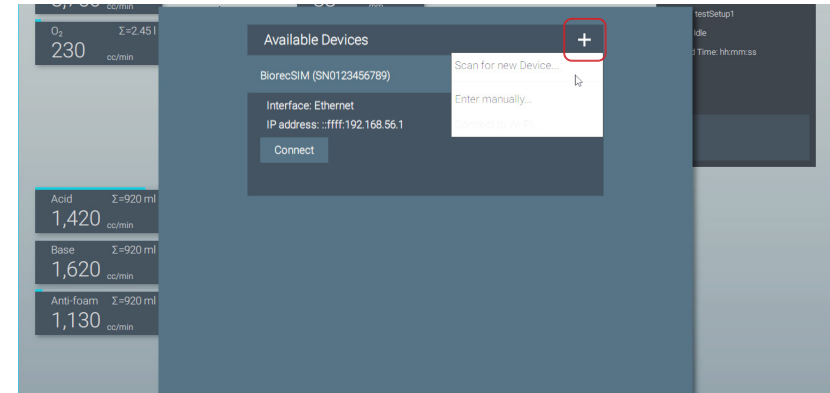

- If the device is turned on, but not discovered by the software, you can enter the information manually to connect the device.

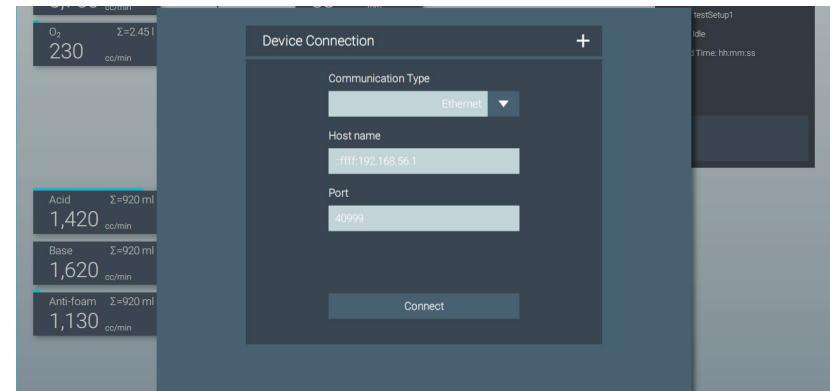

## 2.2 Connection screen

- › The software connects to the device and loads all necessary data.
- › During data synchronization, the connection may be interrupted due to the poor connection quality or the invalid data.
- › The software will show a corresponding error message.

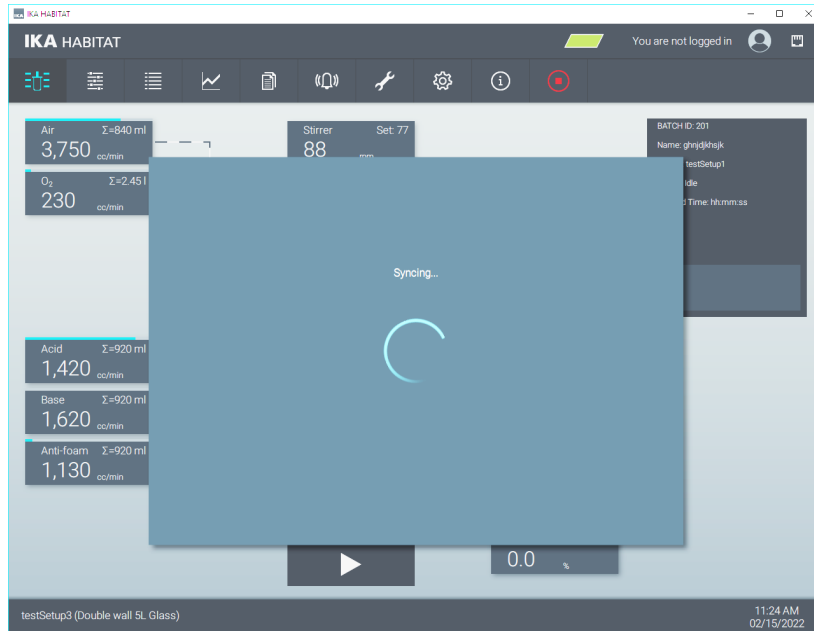

- › After successful data synchronization, the main screen shows the current status. A new log-in is not necessary.

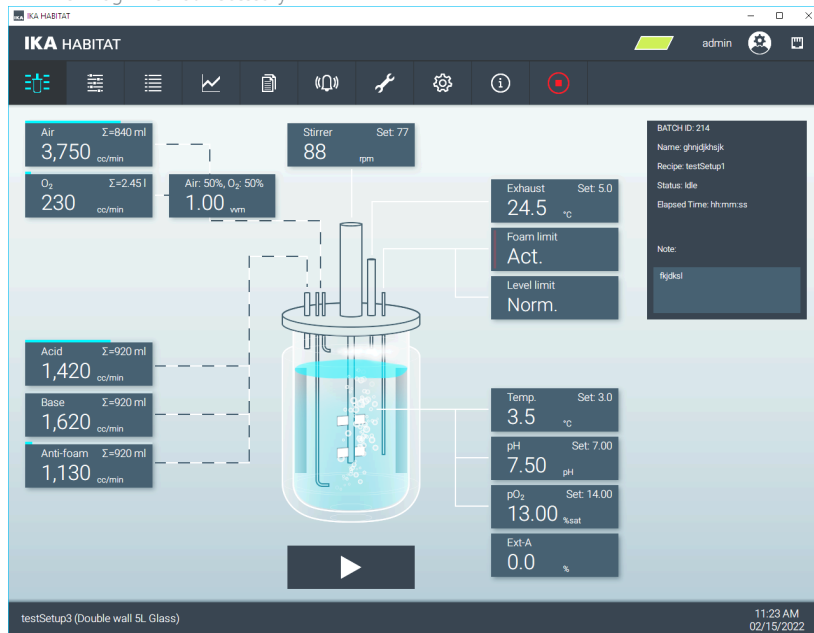

## 2.3 Application Header Menu

### 2.3.1 Header TAB Button

- › For screen navigation
  - ① Process view
  - ② Setup view
  - ③ List view
  - ④ Trend view
  - ⑤ Historical data view
  - ⑥ Alarm view
  - ⑦ Maintenance view
  - ⑧ Settings view
  - ⑨ Info view

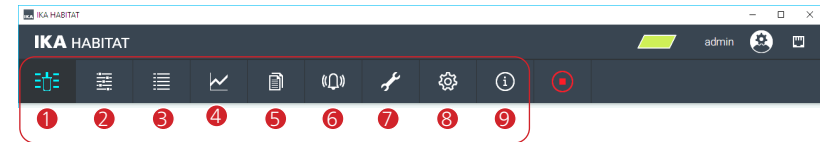

### 2.3.2 Safe-Stop

- › The Safe-Stop (or Emergency) button is needed to stop all the running actions of the device. If the button flashes, the device is in the Safe-Stop mode, the Software is no longer connected to the device and after a short time the screen "Available devices" (2.1) is shown.
- › To restart the operation, the Safe-Stop button on the control unit must be pressed.

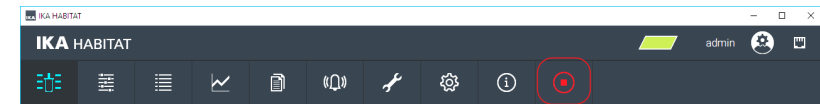

### 2.3.3 System color

- › The color indicates which control unit is connected to the Software.
- › The system color is synchronized with the LED color on the front of the control unit. The color can be changed by clicking on the color icon.

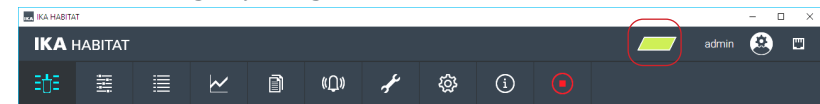

## 2.4 Application Bottom Menu

- ① Display current setup.
- ② Current device time. Click to synchronize the device time with the Tablet / PC.



## 2.5 Process view

- › Start screen with schematic illustration of the reactor vessel:
  - Display of components of the current configuration
  - Overview of measured values and process parameters
  - Open the controller menus

- 1 Log-in user menu and user account (Add, Edit and Delete)
- 2 Connection status display of the currently selected connection type (Ethernet, Wi-Fi® or Serial port)
- 3 Device color indicator
- 4 Safe-Stop
- 5 Device date / time
- 6 Experiment Start button (start data logging and auto mode functions)
- 7 Display selected recipe

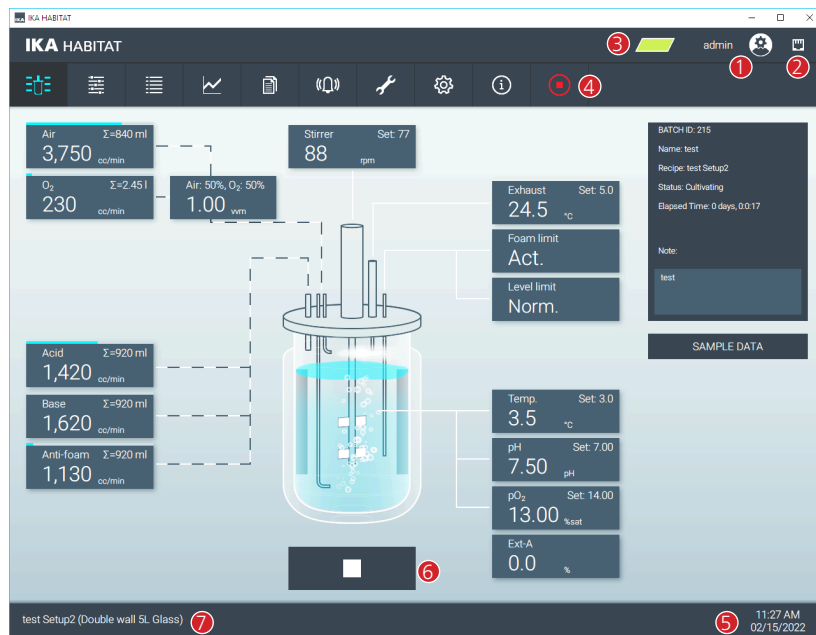

### 2.5.1 Batch information display

- › Display information of current / last batch, such as ID, name, recipe used, status, time elapsed and user information entered.

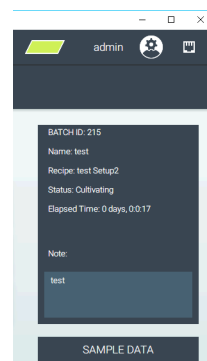

### 2.5.2 Login

- › Before the user is able to change any parameters value or configuration, the user is required to log in to the device first.
- › Enter user name and password.
- › After log-in, the user name and the user icon are displayed.

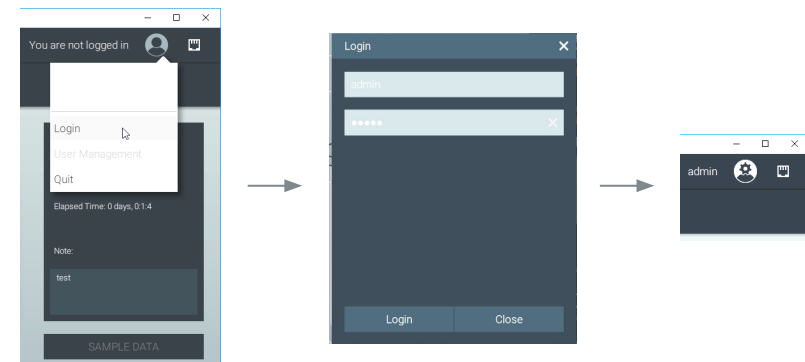

### › User + Access + Right matrix

	Guest (Anonymous, no need to login)	Monitor	Operator	Admin	Service
Access to the Process view	<input checked="" type="checkbox"/> Read-only	<input checked="" type="checkbox"/> Read-only	<input checked="" type="checkbox"/> Full access	<input checked="" type="checkbox"/> Full access	<input checked="" type="checkbox"/> Full access
Access to the List view	<input checked="" type="checkbox"/> Read-only	<input checked="" type="checkbox"/> Read-only	<input checked="" type="checkbox"/> Read-only	<input checked="" type="checkbox"/> Read-only	<input checked="" type="checkbox"/> Read-only
Access to the Trend view	<input checked="" type="checkbox"/> Read-only	<input checked="" type="checkbox"/> Full access	<input checked="" type="checkbox"/> Full access	<input checked="" type="checkbox"/> Full access	<input checked="" type="checkbox"/> Full access
Access to the Setup view	<input checked="" type="checkbox"/> Read-only	<input checked="" type="checkbox"/> Read-only	<input checked="" type="checkbox"/> Full access	<input checked="" type="checkbox"/> Full access	<input checked="" type="checkbox"/> Full access
Access to the Maintenance view		<input checked="" type="checkbox"/> Read-only	<input checked="" type="checkbox"/> Sensor calibration <input checked="" type="checkbox"/> Pump calibration	<input checked="" type="checkbox"/> Sensor calibration <input checked="" type="checkbox"/> Pump calibration <input checked="" type="checkbox"/> Controller parameters	<input checked="" type="checkbox"/> Sensor calibration <input checked="" type="checkbox"/> Pump calibration <input checked="" type="checkbox"/> Controller parameters
Access to the Application settings		<input checked="" type="checkbox"/> Read-only	<input checked="" type="checkbox"/> Full access	<input checked="" type="checkbox"/> Full access	<input checked="" type="checkbox"/> Full access
Access to the System settings				<input checked="" type="checkbox"/> Factory reset <input checked="" type="checkbox"/> Save setting <input checked="" type="checkbox"/> Upload setting <input checked="" type="checkbox"/> Database backup <input checked="" type="checkbox"/> Database restore <input type="checkbox"/> Change device type <input type="checkbox"/> Change logging level <input type="checkbox"/> Change number of log file to keep <input type="checkbox"/> Enable/disable 21-CFR mode	<input checked="" type="checkbox"/> Full access
Access to the User Management Start / Stop process			<input checked="" type="checkbox"/> Full access	<input checked="" type="checkbox"/> Full access	<input checked="" type="checkbox"/> Full access
Access user-self information		<input checked="" type="checkbox"/> Read-only	<input checked="" type="checkbox"/> Full access	<input checked="" type="checkbox"/> Full access	<input checked="" type="checkbox"/> Full access
Access to deleted/archived data					<input checked="" type="checkbox"/> Access switch button to show / hide archived recipe and historical data
Safe stop button		<input checked="" type="checkbox"/> Read-only	<input checked="" type="checkbox"/> Full access	<input checked="" type="checkbox"/> Full access	<input checked="" type="checkbox"/> Full access

### 2.5.3 Stirrer Control

- › Mode:
  - Off: Turn off the stirrer
  - Manual: Set the stirring speed manually (independent of other parameters).
  - Cascade – DO control: Stirrer control by DO cascade controller. Only the stirring direction can be set here.
  - Profile: Preset of up to 10 values, which are run within a certain time period.
  - Profile ramp: Preset up to 10 values that linearly increase or decrease the stirrer speed to the target speed within a specified time.
  - Chaotic: Set the upper and lower speed limits and duration for the chaotic stirring. This is based on an algorithm that randomly calculates the speed within a defined frame. The algorithm is used to optimize the stirring time.

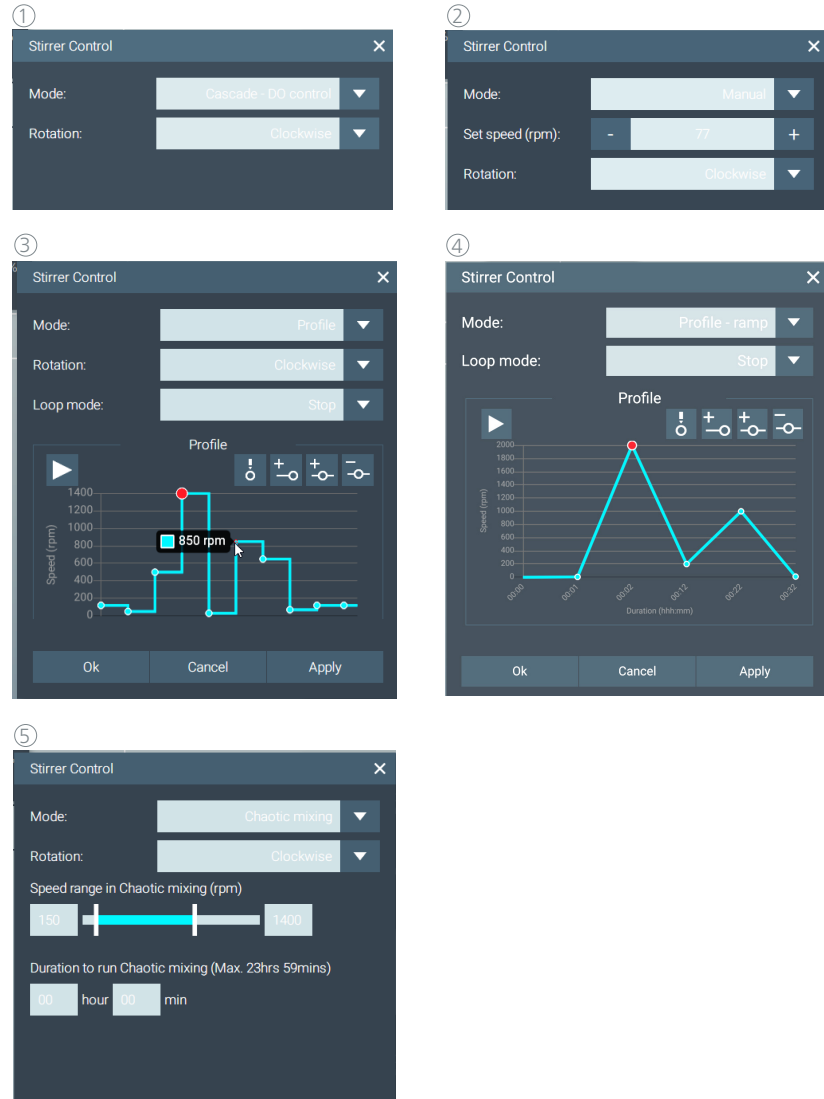

### 2.5.4 Gas Control (Air, O<sub>2</sub>, N<sub>2</sub>, CO<sub>2</sub>)

- › Mode:
  - Off: Turn off the gas module
  - Manual: Set the gas flow rate manually (independent of other parameters).
  - Cascade – DO control: Gas control by DO cascade controller.
  - Profile: Preset of up to 10 values, which are run within a certain time period.

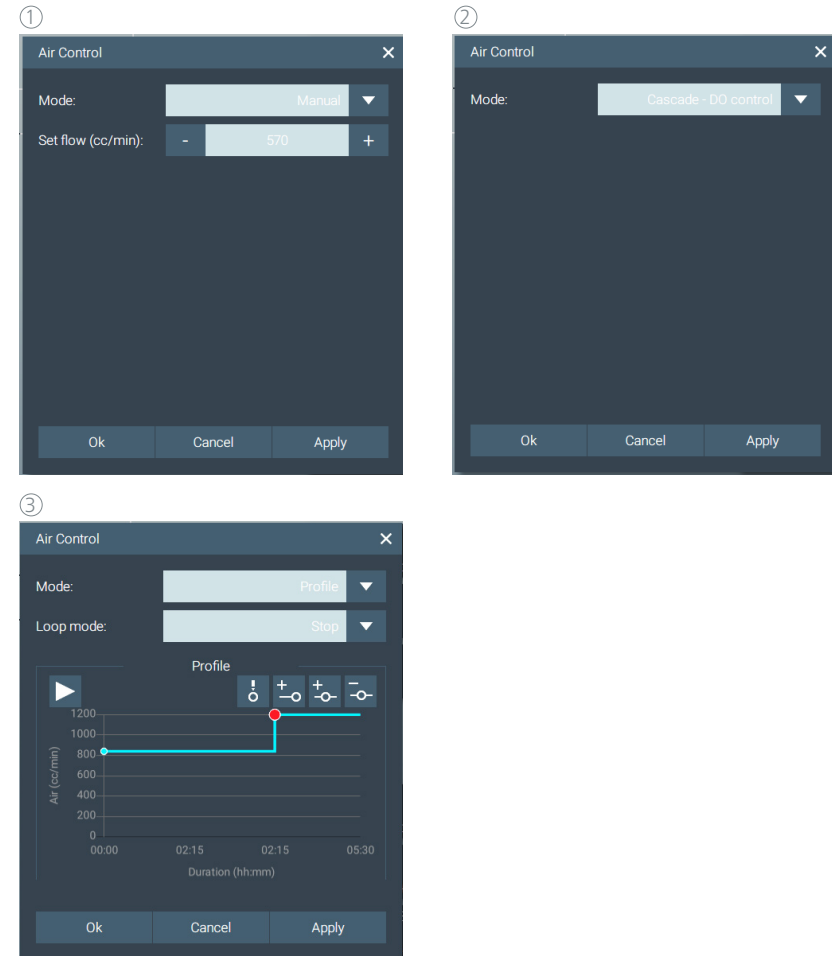

### 2.5.5 Gas Mixer (Air, O<sub>2</sub>)

- > Gas Mixer: Set Air and O<sub>2</sub> control mode to Manual mode.
- > If the Gas Mixer is enabled the set point input from Air and O<sub>2</sub> control will be disabled.
- > **Set flow:** Enter flow rate in vvm (Volume Vessel per Minute), up to 2 vvm.
- > **Set ratio (Slider):** Change the mixing ratio of Air and O<sub>2</sub>.

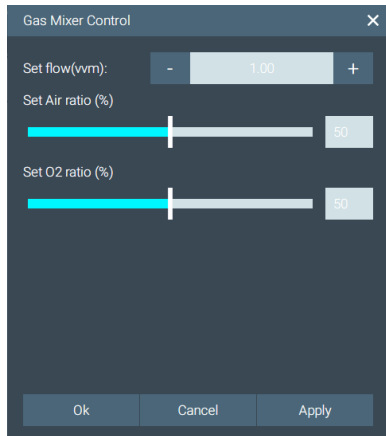

### 2.5.6 Pump Control

- > Mode:
  - Off: Turn off
  - Manual: Set flow rate, volume and rotation direction of the pump manually.
  - Auto – pH control: The pump volume will be controlled by the pH controller. The pump speed and direction can be adjusted in this mode.
  - Profile: Preset of up to 10 values to be run within a certain time period.
- > Calibration information:
  - Show calibration information: If the parameters (for example the hose size used) are out of range, a recalibration should be performed.
  - Calibrate: Pump or hose calibration
  - Filling: (pre) filling of the hose

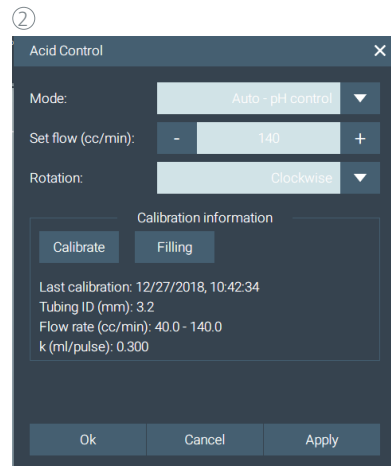
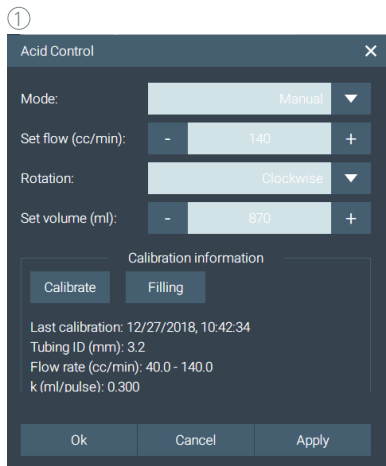

③

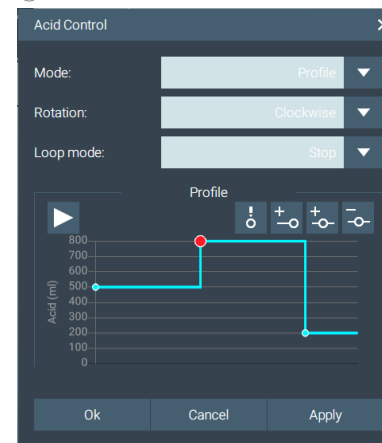

### > Tubing filling

1. Before the calibration, select pump "Filling"
2. Click "Filling"
3. Choose "Tubing ID"
4. Input "Tubing length" in cm
5. Start "Filling"
6. Wait until "Filling" is completed

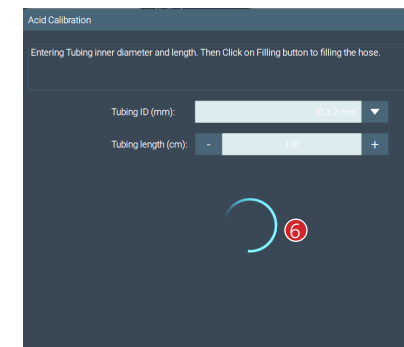
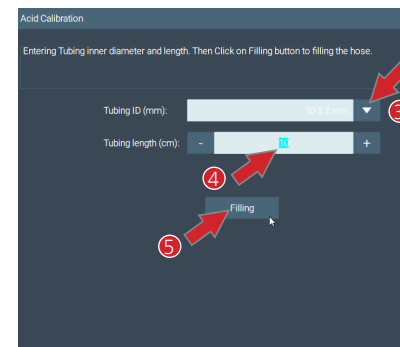
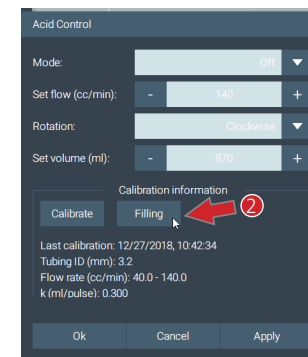
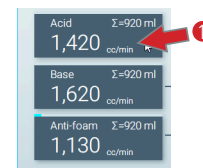

### 2.5.6.1 Special feeding mode for Anti-foam Control

Mode:

- Cascade – DO (Lower Active): auto active feeding when actual DO value is lower than set DO value.
- Cascade – DO (Over Active): auto active feeding when actual DO value is higher than set DO value.
- Biomass Feed (Lower Active): auto active feeding when actual Biomass A.U. is lower than set A.U. value.
- Biomass Feed (Over Active): auto active feeding when actual Biomass A.U. value is higher than set A.U. value.
- Exponential Feed: active feeding control with “exponential equation” parameters’ setting.

Note: A.U. (absorbance unit)

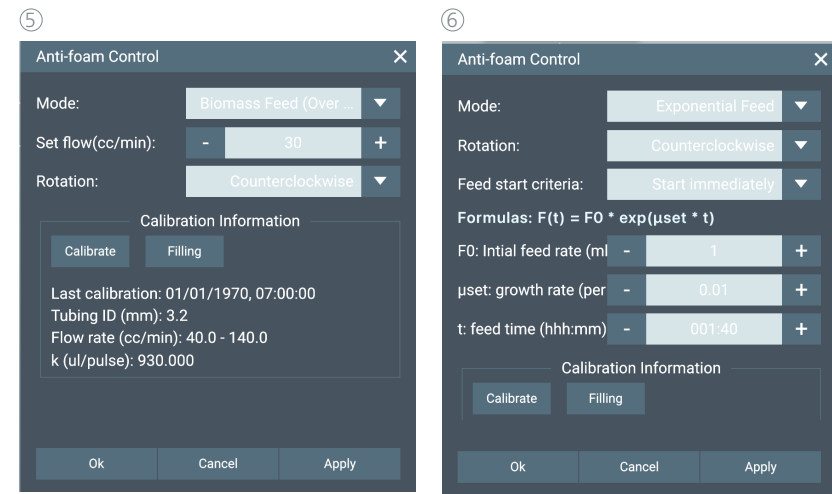
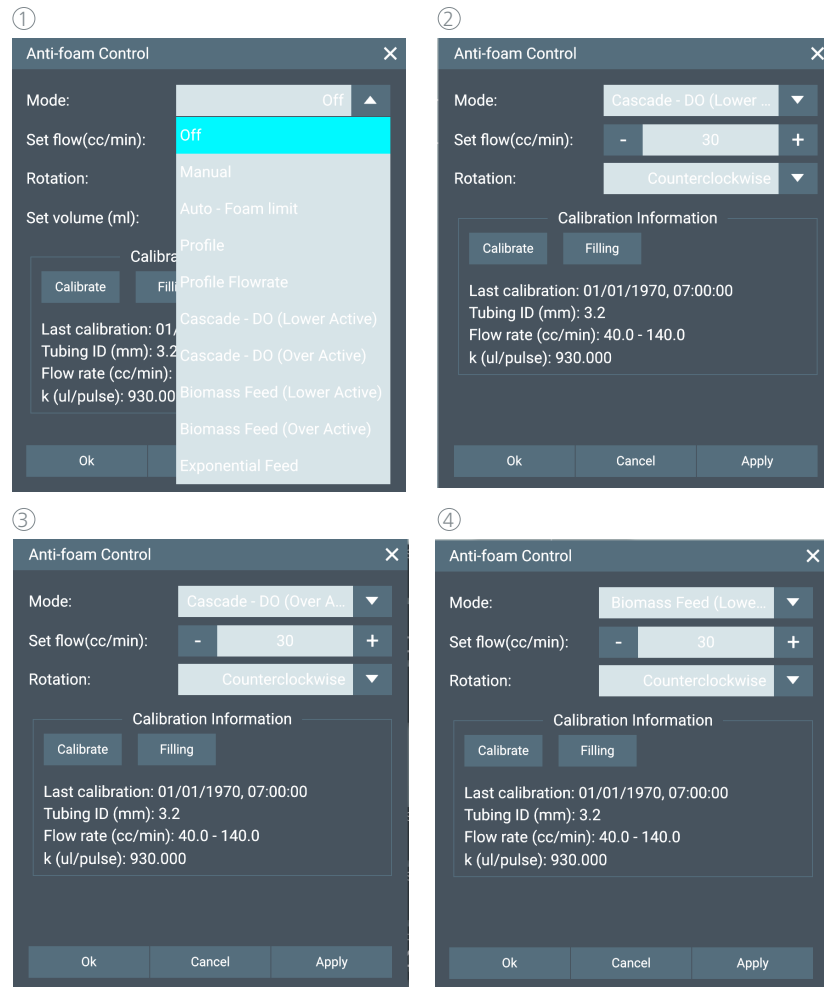

formula [  $F(t) = F_0 * \exp(\mu_{set} * t)$  ]

$F(t)$  → output flowrate/gravimetric feedrate

$F_0$  → initial feedrate/gravimetric feedrate : set by user

exp → mathematical exponential function

$\mu_{set}$  → set federate : set by user; typical range is 0.05 – 0.4 but can be lower/higher dependent on the microorganism

t → time since feedstart : automatic

### 2.5.6.2 Special feeding mode for Feed Control

› Mode:

- RQ feeding (Lower Active): auto active feeding when actual RQ value is lower than set RQ value.
- RQ feeding (Over Active): auto active feeding when actual RQ value is higher than set RQ value.
- Gravimetric: Weight-based rate feeding control in g/h, with Balance device for flask weight measurement.
- Profile Gravimetric: Weight-based rate feeding control in g/h, with Balance device for flask weight measurement, preset of up to 10 values as profile.
- Profile Flowrate: feeding rate control in g/h and duration, preset of up to 10 values as profile.
- pH Feed (Lower Active): auto active feeding with target volume and ratio calculation from current fed volume of Base pump.
- pH Feed (Over Active): auto active feeding with target volume and ratio calculation from current fed volume of Acid pump.
- Cascade – DO (Lower Active): auto active feeding when actual DO value is lower than set active pO<sub>2</sub> value defined in this control.
- Cascade – DO (Over Active): auto active feeding when actual DO value is higher than set active pO<sub>2</sub> value defined in this control.

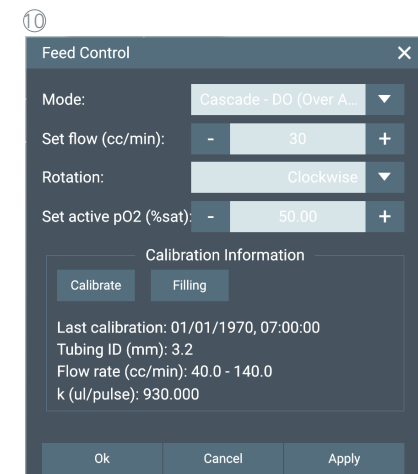
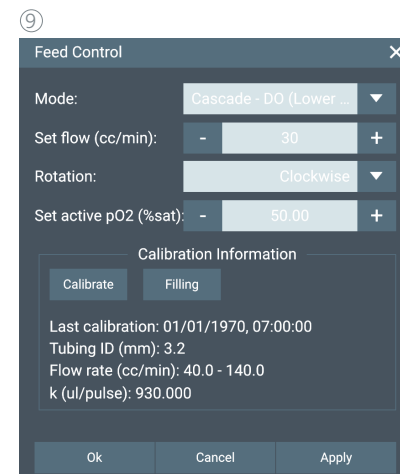
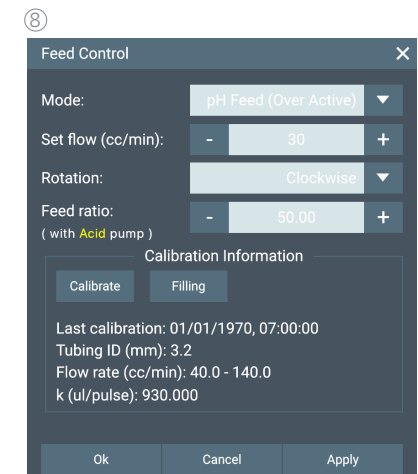
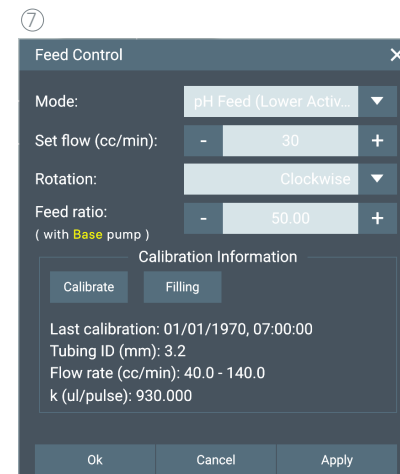
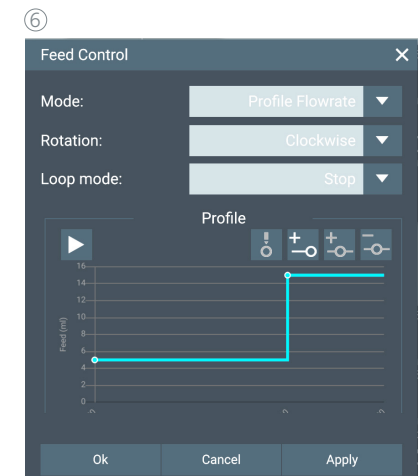
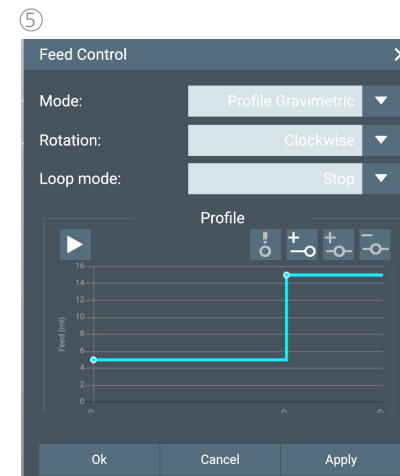
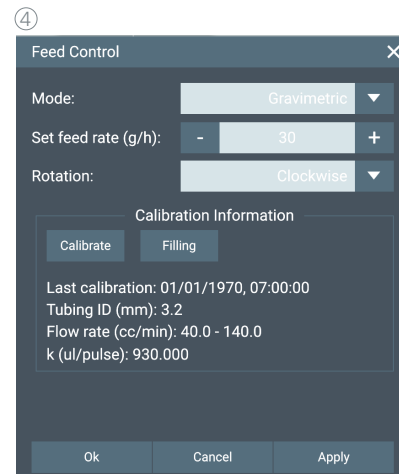
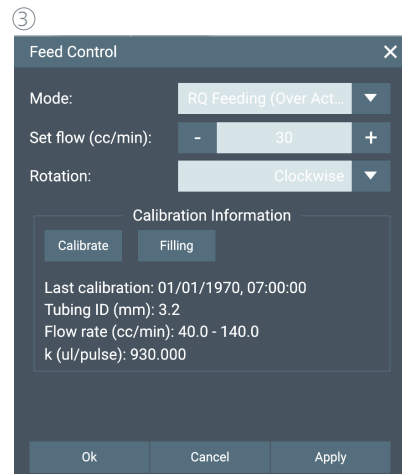
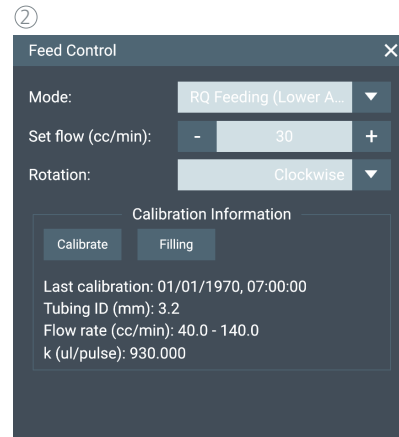
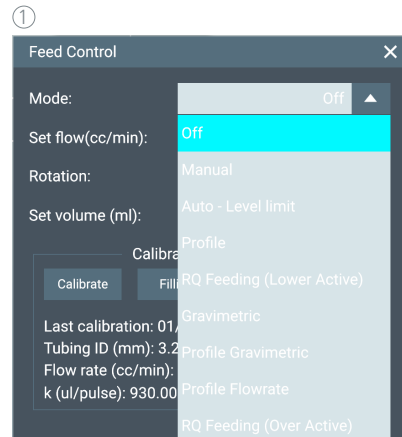

### 2.5.7 Exhaust Control

- › Mode:
  - Off: Turn off
  - Auto: The controller will automatically control the filter heating temperature according to the setpoint value.
  - Peltier Off/On

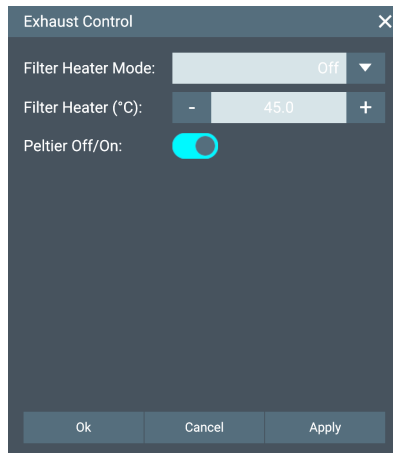

### 2.5.8 Foam limit Control

- › Mode:
  - Off: The foam sensor will detect the foam level but will not take any further action.
  - Auto: If foam is detected the controller will turn on the Anti-foam pump to add Anti-foam agent.
- › On delay: Anti Foam pump delay time
- › On time: Anti Foam pump switch-on time
- › Sensitivity: Adjust the sensitivity of the foam detection sensor.
- › Status Indicator: Sensor status indicator (Normal / Activate).
- › Double detection: Use both "Foam" and "Level" sensors for foam detection, both sensors must detect the foam, then the automatic AFOAM pump feeding will be active.

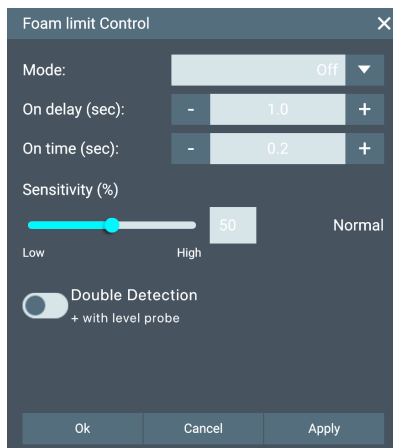

### 2.5.9 Level limit Control

- › Mode:
  - Off: The sensor will detect the level but will not take any further action.
  - Auto: If the level limit is detected, the controller will turn on the level pump to feed / harvest the medium.
- › On delay: The time delay after the level sensor is active and before the Level pump Feed / Harvest.
- › On time: Duration for pumping.
- › Sensitivity: Adjust the sensitivity of the level detection sensor.
- › Status Indicator: Sensor status indicator (Normal / Activate).
- › Level control mode: Control the pump direction (Harvest: suck out / Feed: Fill-in)

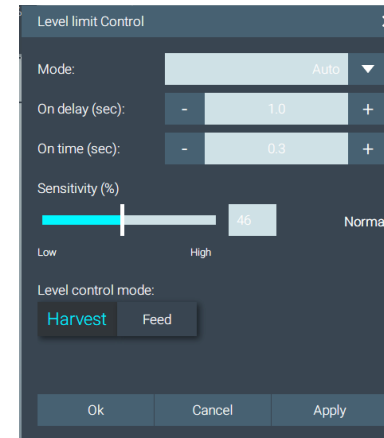

### 2.5.10 Temperature Control

- › Mode:
  - Off: Turn off
  - Auto-Control: Reactor temperature control according to the setpoint specification.
  - Profile: Preset of up to 10 values to be run within a certain time period.
- › Set value offset: Input of a temperature offset value
- › Actuator: Select Heat blanket / Thermostat (IKA HRC 2) to control the temperature of the reactor vessel.

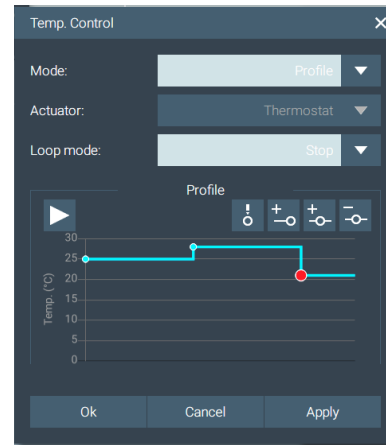
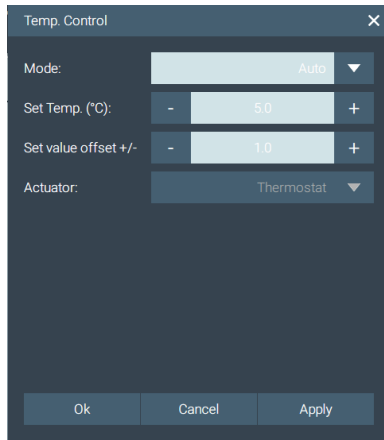

### 2.5.11 pH Control

- › Mode:
  - Off: Turn off
  - Auto: Control process pH value according to the setpoint specification by activating the acid and base pumps, if these have also been set to "auto".
  - Profile: Preset of up to 10 values to be run within a certain time period.
- › Set value offset: Input of a pH value offset value.
- › Digital sensor (Disable / Enable): Use the digital pH sensor as a reference for pH measurement and control.
  - Device ID: User defines the unique ID (2 ... 255) that matches the Modbus-Device address setting for the digital sensor.

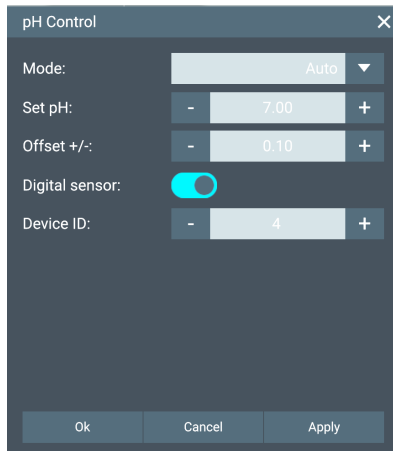

### 2.5.12 pO<sub>2</sub> Control

- › Mode:
  - Off: Turn off
  - Manual: Control the output power (%) of the pO<sub>2</sub> controller directly with the Cascade control setting in the setup.
  - Auto: Enter pO<sub>2</sub> value (% saturate) with the Cascade control setting in the setup.
  - Profile: Preset of up to 10 values to be run within a specified time period.
- › pO<sub>2</sub> Cascading: Graphical visualization of the cascade control values.
- › Digital Sensor (Disable / Enable): Use DO digital sensor as a reference for pO<sub>2</sub> measurement and control.
  - Device ID: User defines the unique ID (2 ... 255) that matches the Modbus-Device address setting for the digital sensor.

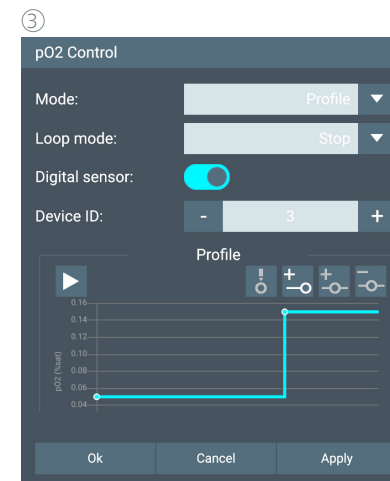
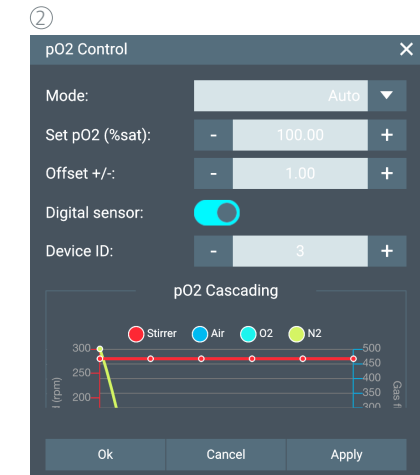
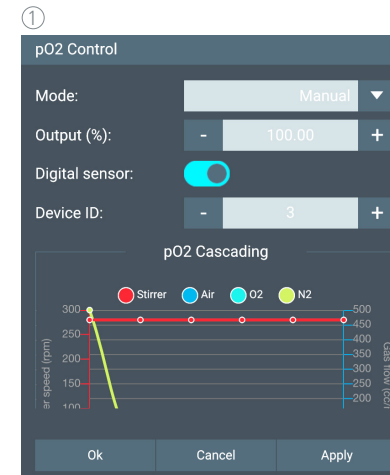

## 2.6 Setup (Recipe) Menu

- › Create, save and restore the setup:
  - Reuse the previous configurations for the experiment.
  - Generate the experiment report after the experiment is finished.
  - Visualization of the process view (for example reactor type, gas, pumps and accessories).

### IMPORTANT:

- › One of the saved setups must be assigned to every experiment before starting!

### 2.6.1 General

- 1 Select experiment mode (Batch, Fed-batch and Continuous)
- 2 Select data recording interval
- 3 Select data saving location: internal control unit, internal or external memory, e.g. USB stick
- 4 Note: Enter notes or information for the setup.
- 5 Load the setup from the device
- 6 Save the current setup in the device
- 7 Reset all settings to default values

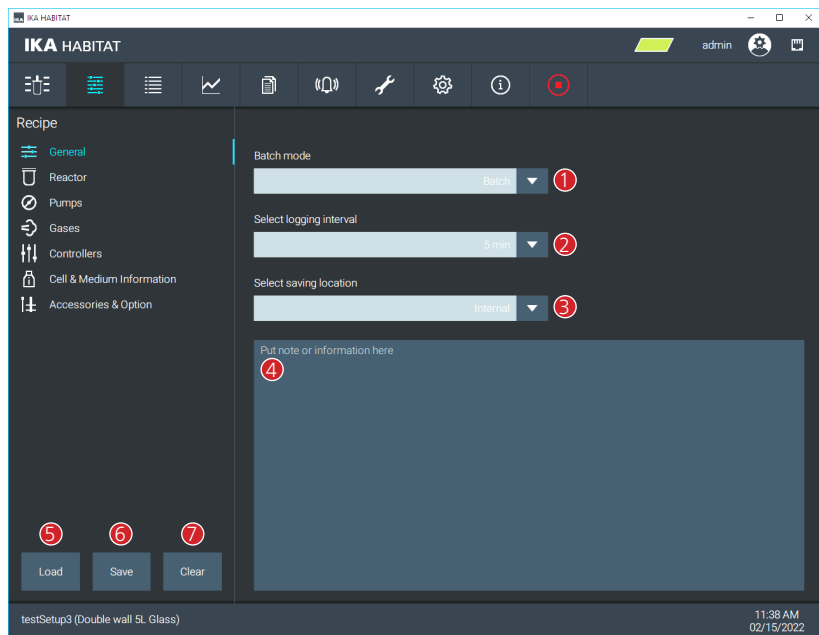

### 2.6.2 Reactor

- 1 Reactor vessel type and size  
(To effect min/max limits of parameter such as Gas flow rate and reactor vessel visualization)
- 2 Sparger type (only for the report)
- 3 Stirrer type (only for the report)
- 4 Number of stirrers (for visualization and report)
- 5 Filter size (only for the report)
- 6 Spin filter size (only for the report)
- 7 Baffles enable / disable (for visualization and report)
- 8 Harvest pipe enable / disable (for visualization and report)
- 9 Cooling finger enable / disable (for visualization and report)

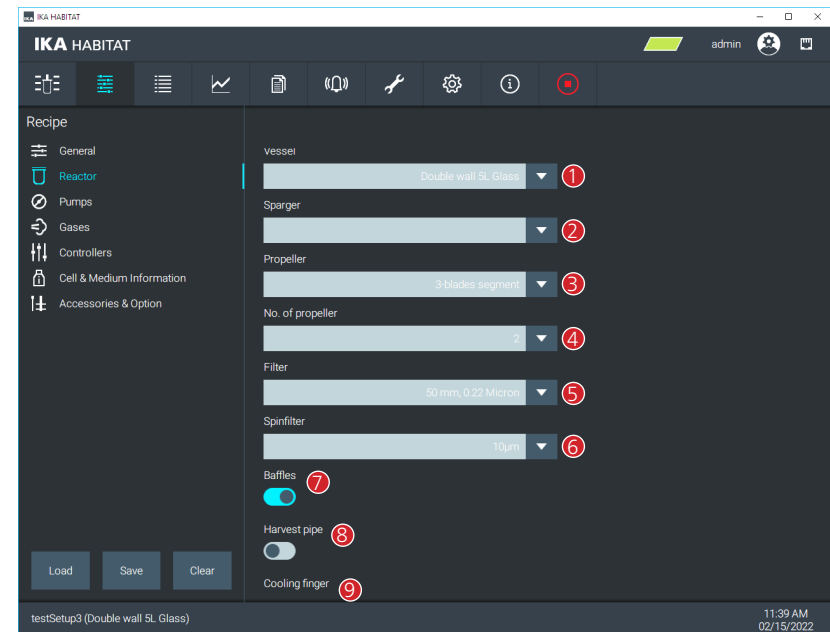

### 2.6.3 Pumps

- > The control unit consists of 4 built-in pumps: Pump A (top) to Pump D (bottom).
- > It is also possible to add an external pump called Ext A.
- ① To enable / disable the pump. A disabled pump will not be shown and can not be controlled.
- ② Combo box is used to assign the parameters to the pump (Acid, Base, Anti-foam, Level and Substrate / Feed)

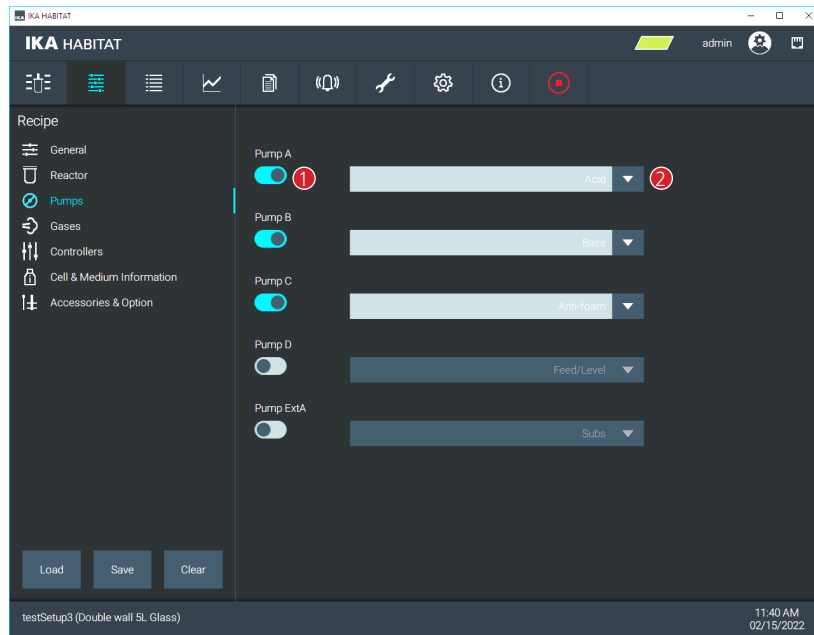

### 2.6.4 Gases

- ① Enable / Disable up to 4 gas modules for the experiment.
- ② Enable / Disable the Gas Mixer (Air, O<sub>2</sub>). When the Gas mixer is enabled the flow rate of Air and O<sub>2</sub> is controlled by the Gas mixer.

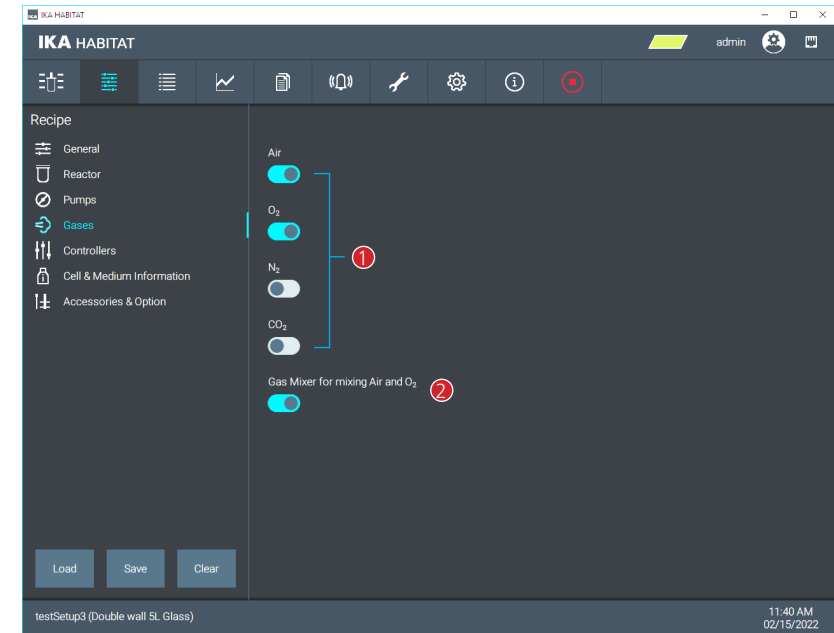

## 2.6.5 Controllers

### 2.6.5.1 pO<sub>2</sub> controller

- ① Enable / Disable parameters to control the pO<sub>2</sub> value
- ② Cascade table to control the pO<sub>2</sub> value
- ③ Plus / Minus button: add / remove table rows (min. 2 / max. 6)
- ④ Apply button: assign the edited table to the device. (This is useful during experiment running if the user would like to update to new control strategy or to find a proper strategy before adding it into the recipe.)
- ⑤ Select the output path  
(Information for the report: Which gas feed was selected)

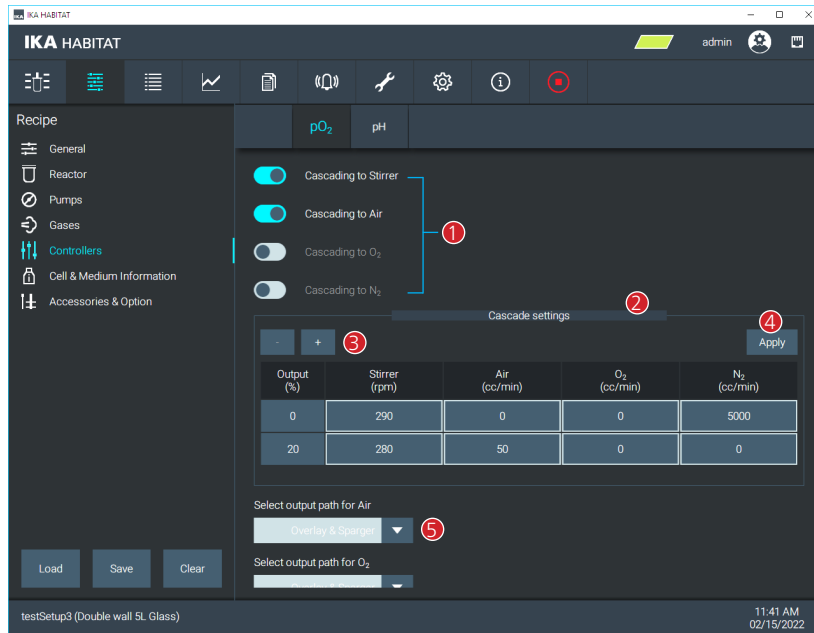

### 2.6.5.1.1 DO cascade control (only) with the stirrer

- › To have the DO control by the stirrer speed adjustment, and then the constant flowrate for the gas input.
- › Set the "DO cascade table"

  - ① Select the tab "Setup recipe"
  - ② Select the "Controllers"
  - ③ Select the tab "pO<sub>2</sub>"
  - ④ Enable the "Cascading to Stirrer"
  - ⑤ Define the "minimum speed", ROW-0%  
Define the "maximum speed", ROW-20%
  - ⑥ Click "Apply" to save the settings

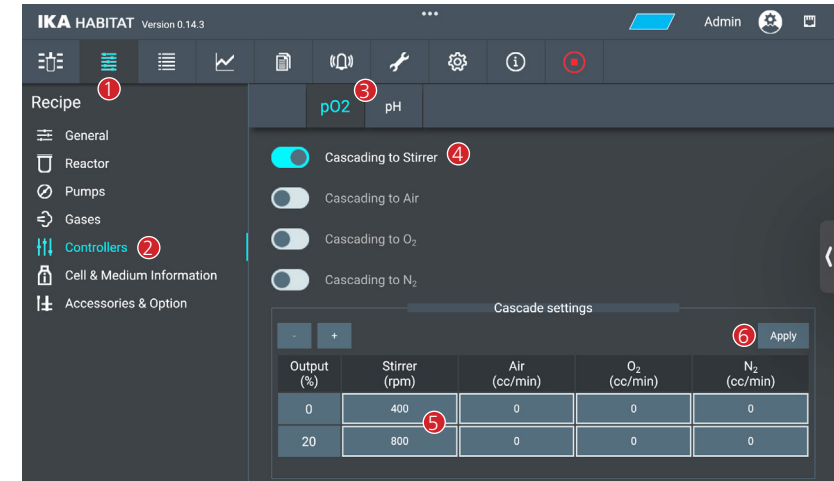

- › Operating the pO<sub>2</sub> control in "Auto" mode.

- ① Open the "pO<sub>2</sub>" module
- ② Select the mode "Auto"
- ③ Define the set DO value (minimum control level), unit: %sat
- ④ Define the "offset +/-" (acceptable tolerance)

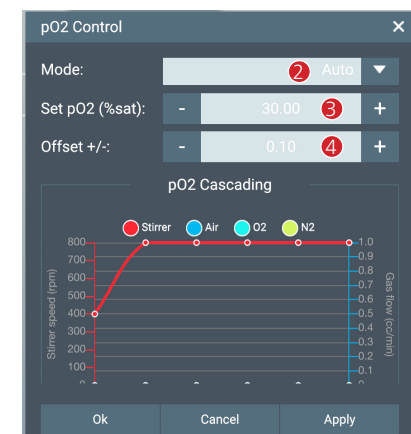
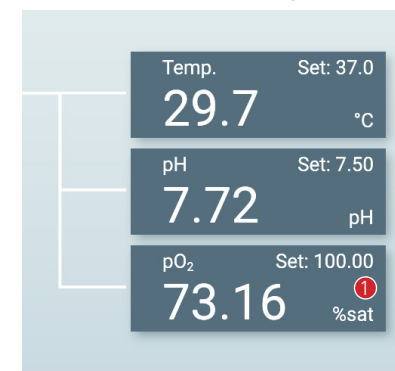

> Operating the Stirrer in "Cascade - DO control" mode

- ① Open the "Stirrer" module
- ② Select the mode "Cascade – DO control"
- ③ Click "Apply" or "Ok" to save the settings

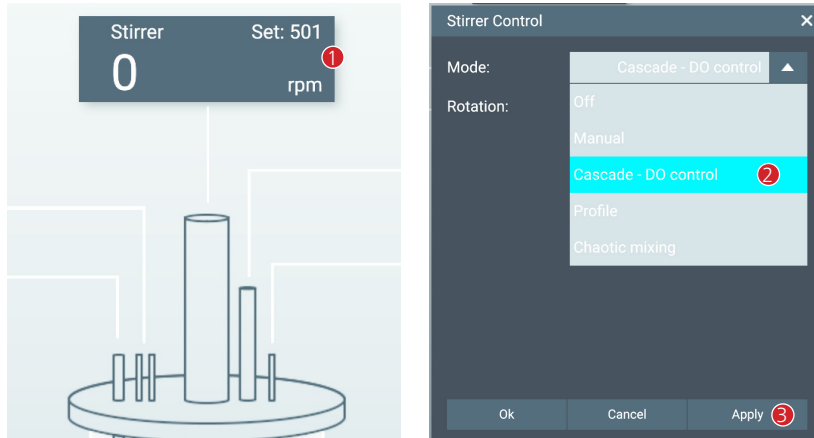

> Operating the Gas module in "Manual" mode

- ① Open the "Air" module
- ② Select the mode "Manual"
- ③ Define the flow rate setpoint value, unit: cc/min
- ④ Click "Apply" or "Ok" to save the settings

**NOTE:** If another gas is required, repeat the first step for O<sub>2</sub>, N<sub>2</sub>, or CO<sub>2</sub> module.

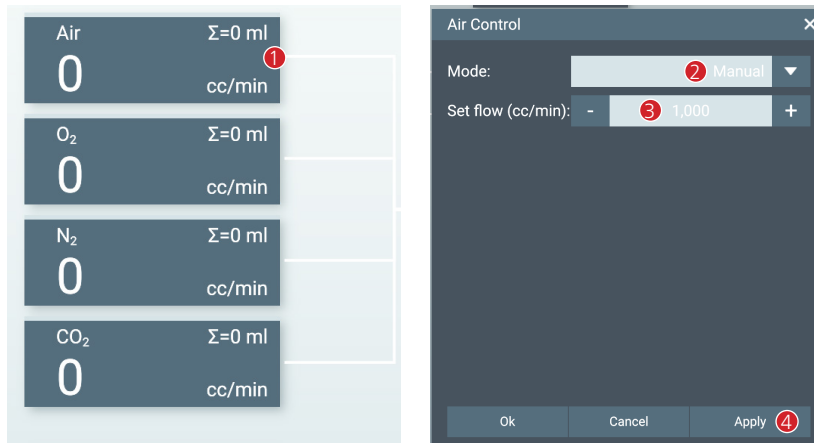

2.6.5.1.2 DO cascade control by the stirrer and the gas flowrate adjustment

> Set the "DO cascade table"

Option 1: To have DO control by stirrer speed and Gas flowrate adjustment in the same time.

- ① Select the tab "Setup recipe"
- ② Select the "Controllers"
- ③ Select the tab "pO<sub>2</sub>"
- ④ Enable the "Cascading to Stirrer"
- ⑤ Enable the "Cascading to Air, O<sub>2</sub>, or N<sub>2</sub> (if needed)"
- ⑥ Define the "minimum Stirrer speed", ROW-0%  
Define the "maximum Stirrer speed", ROW-20%
- ⑦ Define the "minimum Air flowrate", ROW-0%  
Define the "maximum Air flowrate", ROW-20%
- ⑧ Click "Apply" to save the settings

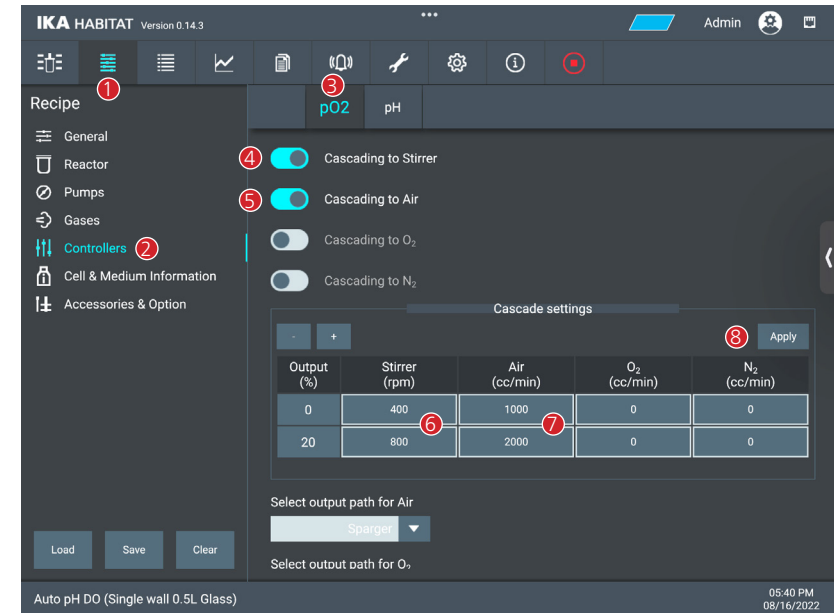

Option 2: To have DO control by stirrer speed as the first step, and then the gas flowrate adjustment in the second step.

- ① Select the tab "Setup recipe"
- ② Select the "Controllers"
- ③ Select the tab "pO<sub>2</sub>"
- ④ Enable the "Cascading to Stirrer"
- ⑤ Enable the "Cascading to Air, O<sub>2</sub>, or N<sub>2</sub> (if needed)"
- ⑥ Define the "minimum Stirrer speed", ROW-0%  
Define the "maximum Stirrer speed", ROW-20% & ROW-40%
- ⑦ Define the "minimum Air flowrate", ROW-0% & ROW-20%  
Define the "maximum Air flowrate", ROW-40%
- ⑧ Click "Apply" to save the settings

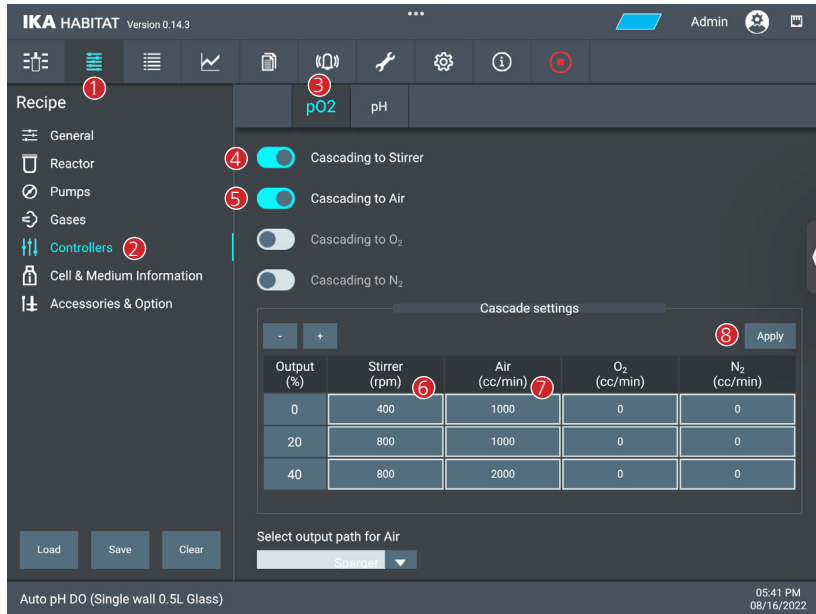

> Operating the PO<sub>2</sub> control in "Auto" mode

- ① Open the "pO<sub>2</sub>" module
- ② Select the mode "Auto"
- ③ Define the set DO value (minimum control level), unit: %sat
- ④ Define "offset +/-" (acceptable tolerance)
- ⑤ Click "Apply" or "Ok" to save the settings

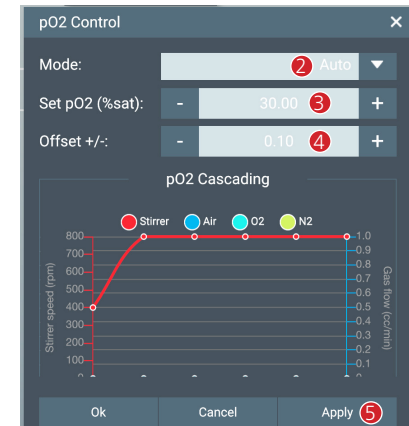
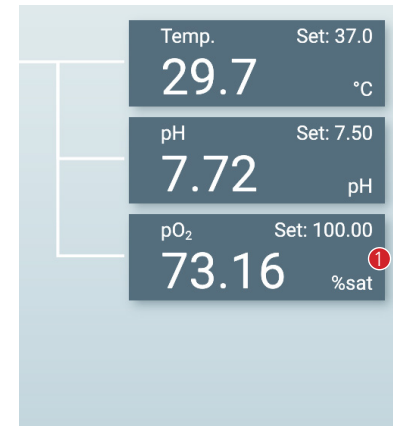

> Operating the stirrer in "Cascade - DO control" mode

- ① Open the "Stirrer" module
- ② Select the "Cascade - DO control"
- ③ Click "Apply" or "Ok" to save the settings

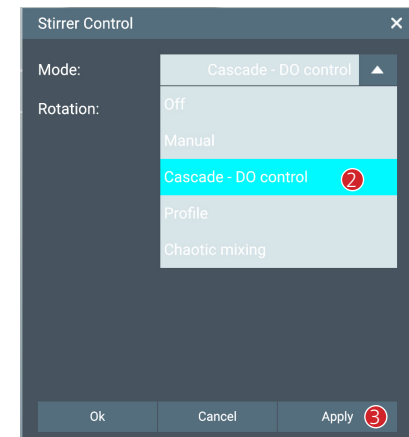
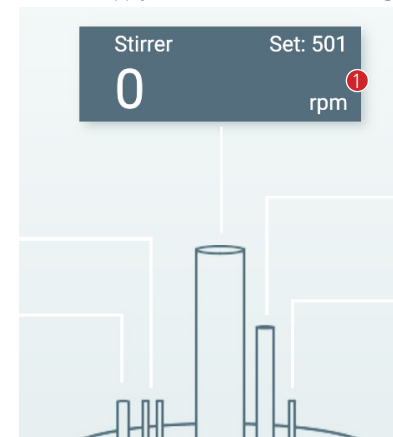

> Operating the Gas in "Cascade - DO control" mode

- ① Open the "Air" module
- ② Select the mode "Cascade - DO control"
- ③ Click "Apply" or "Ok" to save the settings

**NOTE:** If another gas is required, repeat the first step for O<sub>2</sub> or N<sub>2</sub> module.

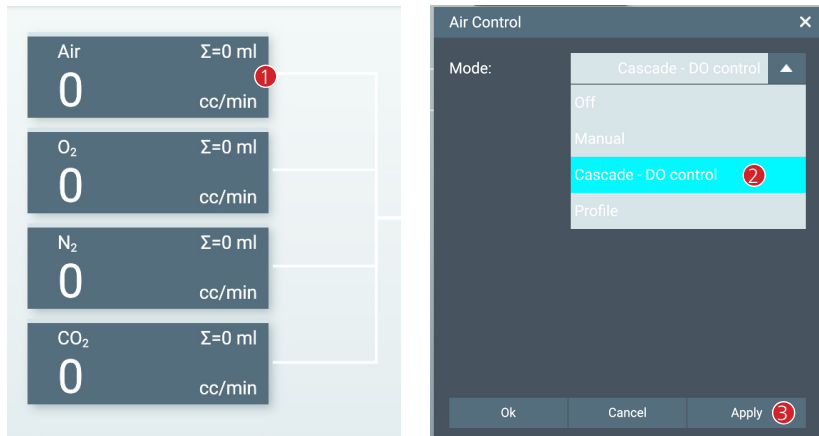

### Important Note

How does the automatic DO control work in the background?

- > The user defines the DO %sat (minimum control level) as the setpoint value.
- > The DO controller will calculate a proper %Output value using the PID algorithm.
  - 0.0 % Output: actual DO %sat is higher than or equal to the setpoint value.
  - 0.1 - 100 % Output: actual DO %sat is lower than the setpoint value.
- > The %Output is used to calculate the setpoint value for each sub-controller within the cascade.

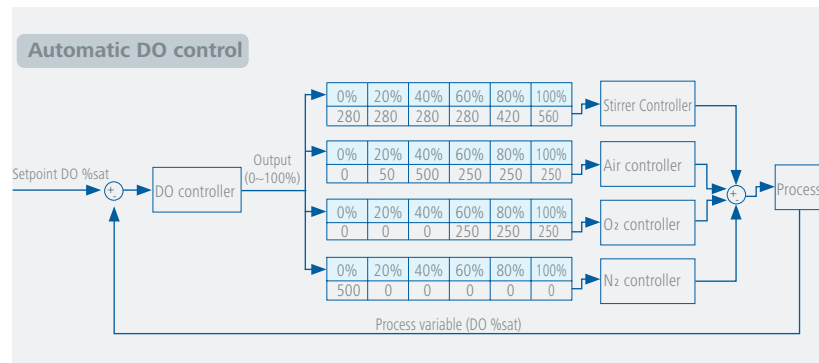

2.6.5.2 pH controller

- ① Enable / Disable the parameters to control the pH value
- ② Select the output path

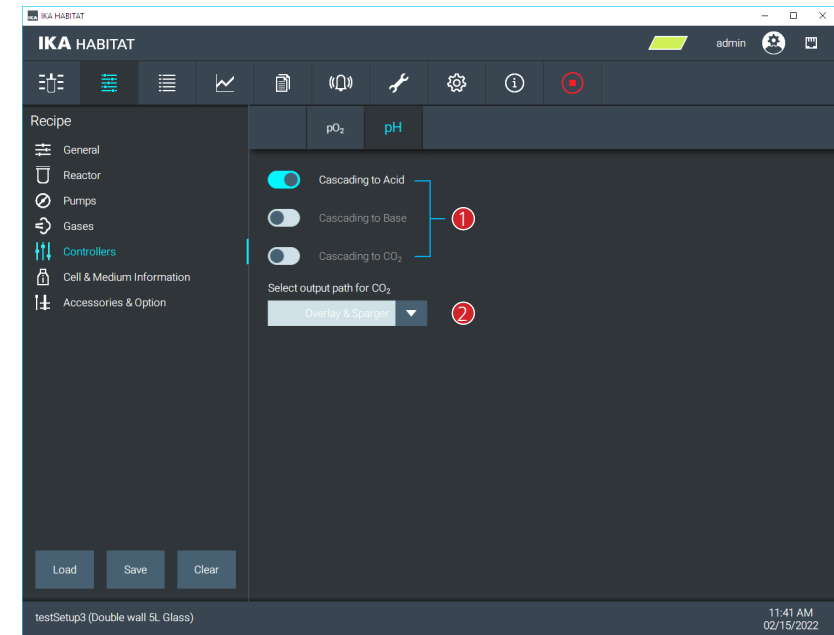

> pH control

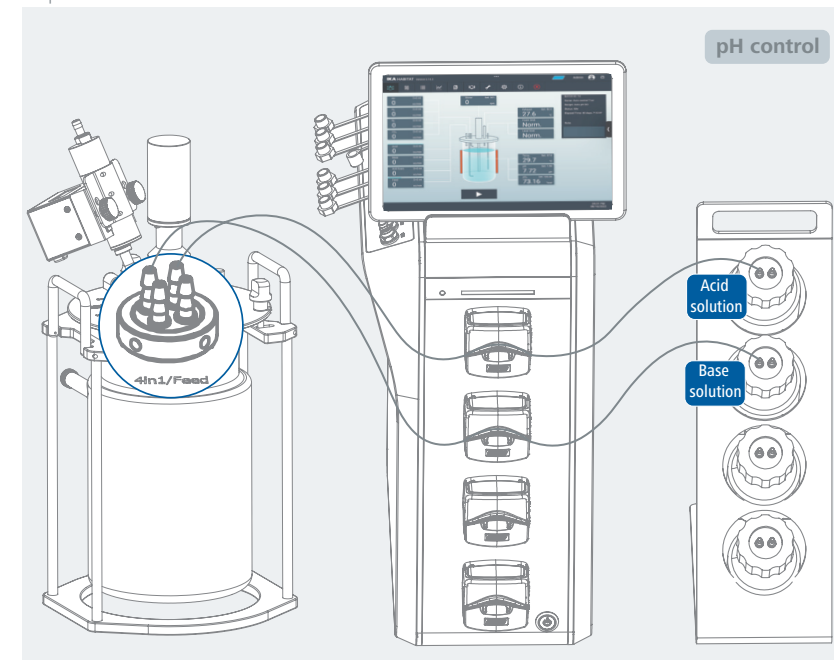

- > pH control with ACID and BASE pump
- > Setting "Auto – pH control" for ACID and BASE pump
- ① Open the "Acid" pump module
- ② Select the mode "Auto – pH control"
- ③ Define pump flowrate (min. and max. values depend on the tube size), unit: cc/min
- ④ Select a proper direction: CW or CCW

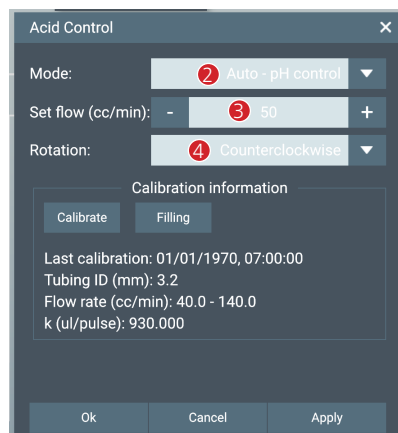
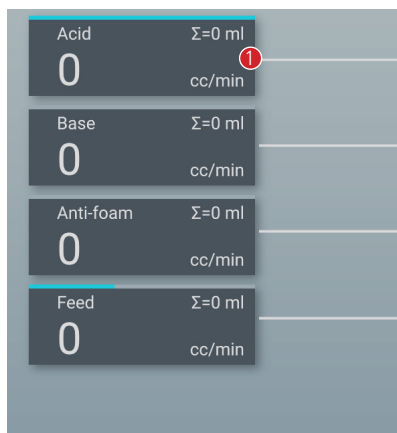

- ⑤ Open the "Base" pump module
- ⑥ Select the mode "Auto – pH control"
- ⑦ Define the pump flowrate (min. and max. values depend on the tube size), unit: cc/min
- ⑧ Select a proper direction: CW or CCW

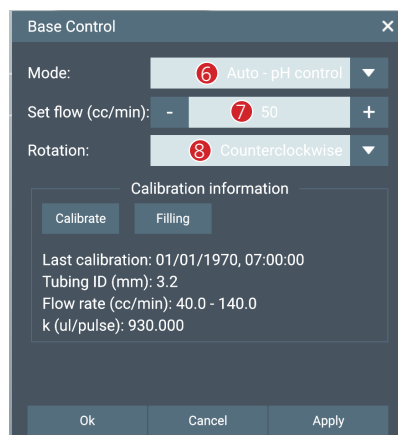
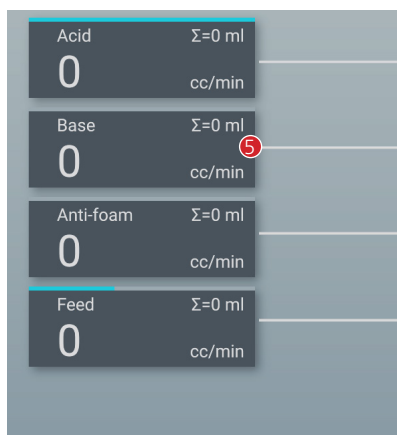

**Note:**  
 cw = clockwise  
 ccw = counter clockwise

- > Setting mode "Auto" for pH module
- ① Open the "pH" module
- ② Select the mode "Auto"
- ③ Define pH set value.
- ④ Define "offset +/-" (acceptable tolerance)

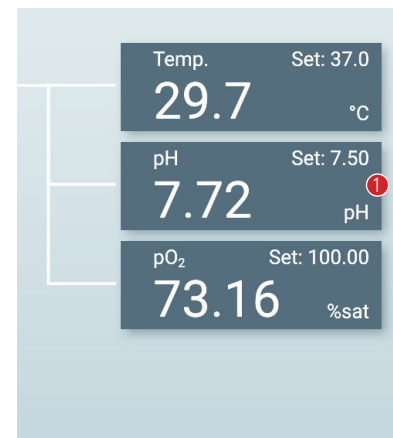

**Important NOTE:**

How does the automatic pH control work in the background?

- > The user defines the pH set-value as setpoint input for the system.
- > The controller determines the difference between the setpoint and actual values measured with the pH sensor.
  - If the actual pH value is within the range of the setpoint (incl. +/- offset), no action is initiated.
  - If the actual pH value is out of the range of the setpoint value (incl. +/- offset) the PID controller calculates the necessary supply of ACID or BASE within a cycle of 30 seconds.

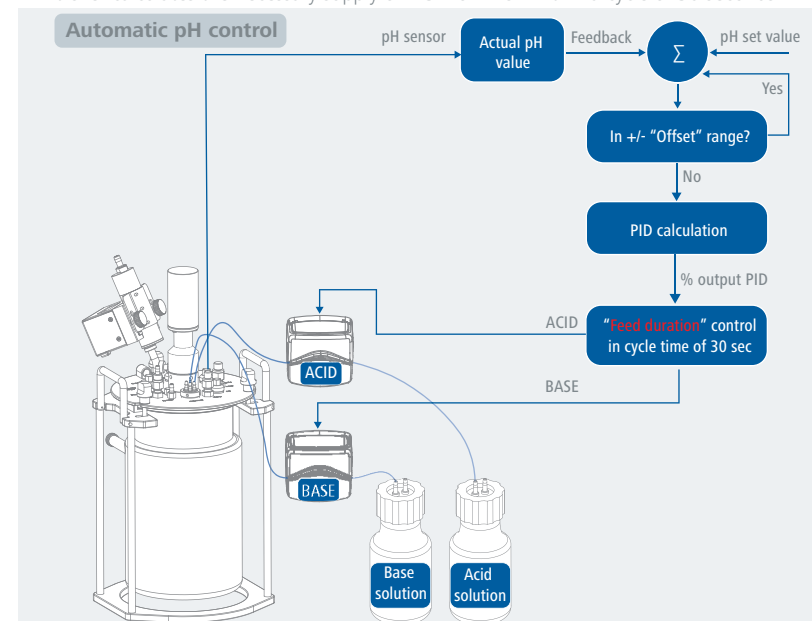

### 2.6.6 Cell & Medium information

- ① Input of cell / product information
- ② Input of culture medium information
- ③ Input of supplement information

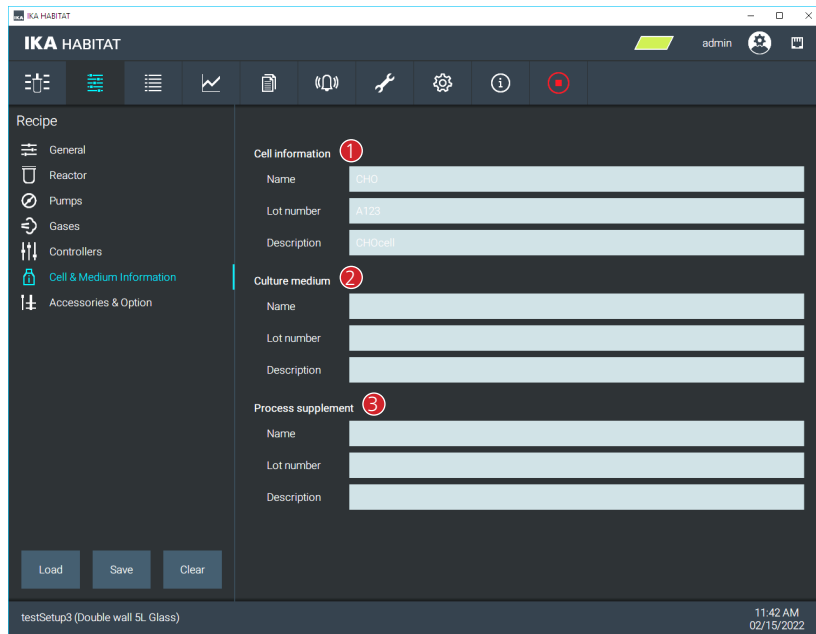

### 2.6.7 Accessories & Option

- ① Enable / Disable Light panel
- ② Enable / Disable CO<sub>2</sub> sensor
- ③ Enable / Disable Conductivity sensor
- ④ Enable / Disable Turbidity sensor
- ⑤ Enable / Disable External signal module
- ⑥ Enable / Disable External signal module

- ⑦ Enable / Disable BlueVary
- ⑧ Enable / Disable CgqBior
- ⑨ Enable / Disable Weight Sensor
- ⑩ Enable / Disable Redox Sensor
- ⑪ Enable / Disable Incyte Sensor
- ⑫ Enable / Disable Excell Sensor

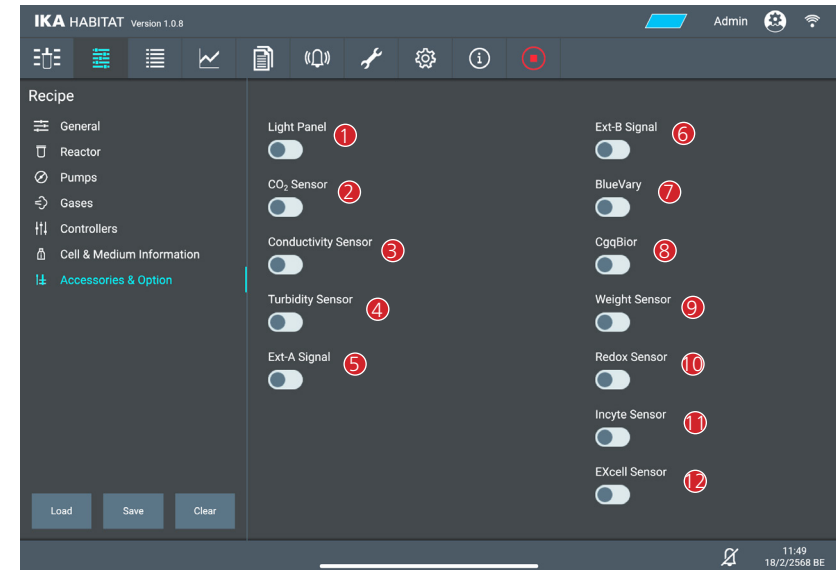

### 2.6.8 Loading a recipe

- ① Table to display all the recipes
- ② Column overview with sorting function (ascending or descending)
- ③ Button to delete the selected recipes
- ④ Selected column to filter the recipes
- ⑤ Input of the filter keywords to filter the recipes
- ⑥ Button to load the selected recipes

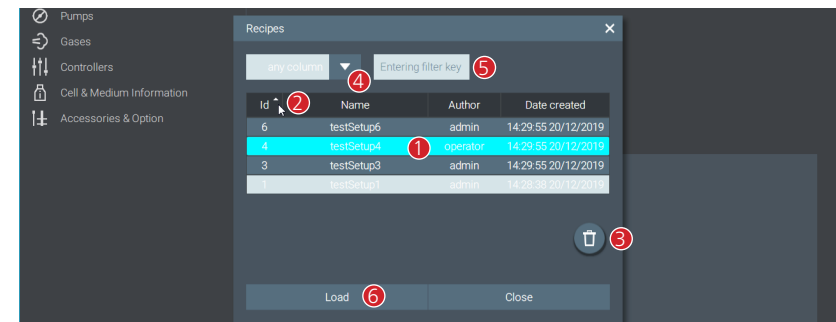

## 2.7 List View Menu

- › Table view of all parameters:
  - Actual value
  - Set value
  - Unit
  - Operating mode
  - Alarm conditions
  - Alarm status
  - Error codes

Name	Actual value	Set value	Unit	Mode	Alarm enabled	Alarm status	Error
Temp.	3.5	3.0	°C	OFF	Disabled	Cleared	0
pH	7.50	7.00	pH	OFF	Disabled	Cleared	0
pO <sub>2</sub>	13.00	14.00	%sat	OFF	Disabled	Cleared	0
Exhaust	24.5	5.0	°C	OFF	Disabled	Cleared	0
Stirrer	98	77	rpm	OFF	Disabled	Cleared	0
Air	3.750	570	cc/min	OFF	Disabled	Cleared	0
O <sub>2</sub>	230	170	cc/min	OFF	Disabled	Cleared	0
N <sub>2</sub>	450	380	cc/min	OFF	Disabled	Cleared	0
CO <sub>2</sub>	420	100	cc/min	OFF	Disabled	Cleared	0
Acid	1,420	1,000	cc/min	OFF	Disabled	Cleared	0
Base	1,620	1,670	cc/min	OFF	Disabled	Cleared	0
Anti-foam	1,130	1,720	cc/min	OFF	Disabled	Cleared	0
Feed	1,380	1,260	cc/min	OFF	Disabled	Cleared	0
Subs	1,425	1,260	cc/min	OFF	Disabled	Cleared	0
Foam limit	2	0		On	Disabled	Cleared	0
Level limit	1	0		OFF	Disabled	Cleared	0
CO <sub>2</sub> probe	0	0		OFF	Disabled	Cleared	0
Conductivity probe	24.81	0	µS/cm	OFF	Disabled	Cleared	0
Turbidity probe	120	0	NTU	OFF	Disabled	Cleared	0
Light panel	0	55	%	OFF	Disabled	Cleared	0

testSetup3 (Double wall SL Glass) 11:42 AM 02/15/2022

## 2.8 Trend View Menu

- › Graphical display of current data.
- › Data is updated when the software is connected to the IKA HABITAT or when the device time is changed.
- › For data synchronization, click the Sync button. (Only when the experiment is running, there is no data when the experiment is not running).
- ① Display all current parameter values (click to adjust the color and the scale).
- ② Change the updating time of the graph
- ③ Graph synchronization button
- › To transfer all the data from the device to the software, as the device can be operated without an active user interface.
- BE AWARE:** Depending on the data size of the experiment it may take some time!
- ④ Export Data to CSV or save to USB
- ⑤ Click in the area of the graph to display a cursor line (display of all the values in this area)



- ① Enable / Disable Trend display
- ② Select the parameters to be displayed
- ③ Select the color
- ④ Enable / Disable the function of auto scaling
- ⑤ Set the minimum Y-Axis scaling
- ⑥ Set the maximum Y-Axis scaling

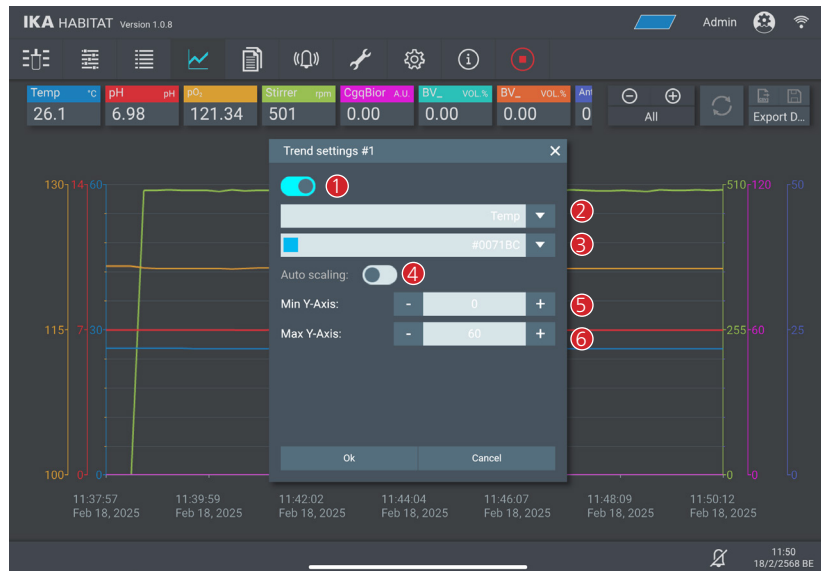

## 2.9 Historical data

- ① Table view of all the experiments
- ② Graph display of historical data series
- ③ Button to export graphical data (PNG format)
- ④ Graph legend, click to show / hide
- ⑤ Button to print the graph
- ⑥ Button to export data as CSV file
- ⑦ Button to create a PDF file
- ⑧ Button to save data to USB drive connected to the control unit
- ⑨ Button to open the Filter menu
- ⑩ Button to delete the selected experiment
- ⑪ Table menu bar to sort the data (ascending / descending)



## 2.10 Alarm view

- › The screen shows the alarm messages for the running experiment. If no experiment is running, the alarm messages will not be recorded.
  - › The alarm messages of each experiment will be saved and listed with the experiment data in the report.
- 1 Table menu bar to sort the data (ascending or descending)
  - 2 Ascending or descending markers for the sorting

The screenshot shows the IKA HABITAT interface with an alarm view. A table lists four alarm messages. Red circles 1 and 2 point to the table menu bar and the sorting markers, respectively.

#	Timestamp	Error code	Description	Value
4	28/2/20 17:23:55	01393805	Temperature Temperature set value not reached	0
3	28/2/20 17:23:55	01392915	Temperature Sensor disconnected	0
2	28/2/20 17:23:55	01290009	Power Supply shut-down	0
1	28/2/20 17:23:55	01030115	Communication BLE disconnected	0

09:02 AM  
08/05/2022

## 2.11 Maintenance Menu

### 2.11.1 Sensor Calibration

- 1 Date / time of last calibration
- 2 Sensor serial number
- 3 Sensor raw value at zero point calibration
- 4 Sensor raw value during slope calibration
- 5 Probe condition: Minus sign means that the sensor is no longer suitable for further experiments and should be replaced.
- 6 CAL button to start the calibration process

The screenshot shows the IKA HABITAT maintenance menu. A table lists calibration data for three sensors: Temp., pH, and pO2. Red circles 1 through 6 point to specific columns in the table.

	Last calibration	serial no.	Zero	Slope	Condition	Action
Temp.	01/01/1970, 07:00:00	IKATEMP001	0.0	0.0/°C	+	CAL
pH	01/01/1970, 07:00:00	IKAPH001	0 mV	59.16 mV (@4 pH)	+	CAL
pO2	01/01/1970, 07:00:00	IKAD00001	0 nA	0 nA/%	-	CAL

### 2.11.2 Pump Calibration

- 1 Date / time of last calibration
  - 2 Tubing inner diameter.
  - 3 Set value of the last pump calibration
  - 4 The value that can be measured by the device when the user specifies a setpoint value.
  - 5 Calibration constant (internal value for setting the pump accuracy)
  - 6 CAL button to start the calibration process
- Filling** button: used to fill an empty tube before calibration, also useful to use before and after the experiment.

The screenshot shows the IKA HABITAT maintenance menu. A table lists pump calibration data for various substances: Acid, Base, Anti-foam, Feed, and Subs-A. Red circles 1 through 6 point to specific columns in the table.

	Last calibration	Tubing ID (mm)	Set (ml)	Measure (ml)	k (ml/pulse)	Action
Acid	02/24/2025, 11:44:55	2.4	3	3	1,034.482	CAL Filling
Base	01/01/1970, 07:00:00	1.2	3	50	930.000	CAL Filling
Anti-foam	01/01/1970, 07:00:00	3.2	50	50	930.000	CAL Filling
Feed	01/01/1970, 07:00:00	3.2	50	50	930.000	CAL Filling
Subs-A	01/01/1970, 07:00:00	1.2	3	0	0.000	CAL Filling

### 2.11.3 Gas Calibration

- › Individual gas calibration by "Slope" and "Offset" value.
- › Users collect the raw flowrate measurement data compared to the standard meter within the interested range, then find the correct slope and offset value from the linear equation  $y = Mx + C$

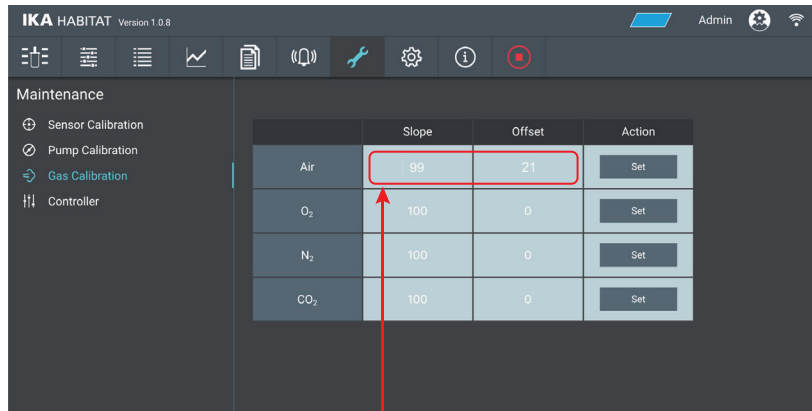

**NOTE:** How to find the slope value for each gas, from raw measurement data?

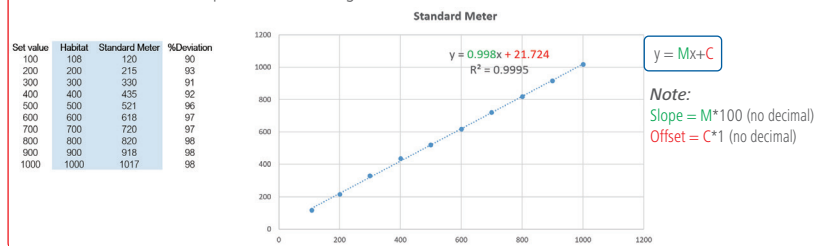

### 2.11.4 Controller

- › This menu is intended for the experienced users with knowledge of PID controller systems to enter their own PID controller parameters.

- ① **kp** constant for the PID controller.
- ② **ki** constant for the PID controller.
- ③ **kd** constant for the PID controller.
- ④ Button to reset the PID controller parameters to default values
- ⑤ pO<sub>2</sub> separate PID for Stirrer (Disable->Enable):  
Disable: Use same PID parameters for Gases and Stirrer  
Enable: Separate PID parameters for Gases and Stirrer.

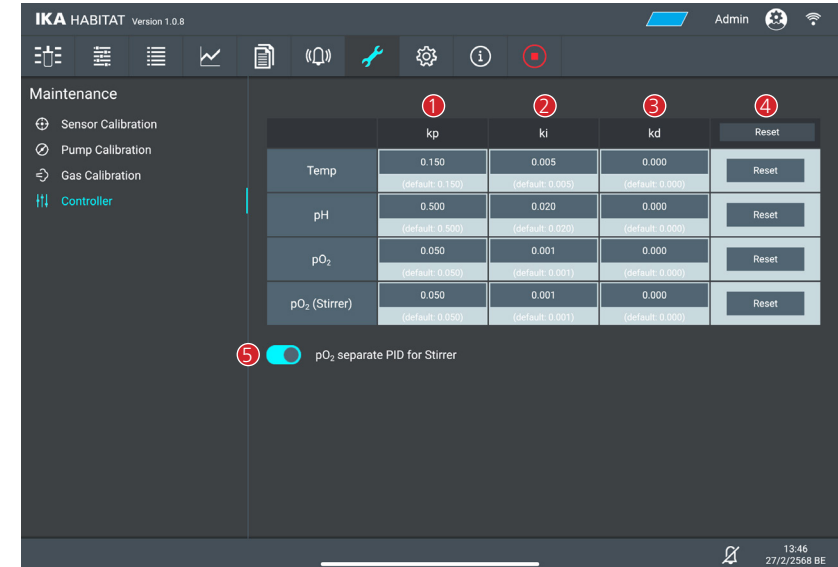

## 2.12 Settings Menu

### 2.12.1 General

- ① Change the device name
- ② Select the user language
- ③ Select the device time zone.
- ④ Set the flow rate unit
- ⑤ Data downsampling Algorithm
  - Average: All data within a 15 minute cycle will be averaged and displayed as one point.
  - LTTB: The algorithm will keep all peaks and valleys of the graph before downsampling to display all data in the original.
- ⑥ Enable / Disable Auto Restart on power failure. The duration of the power failure can be set.

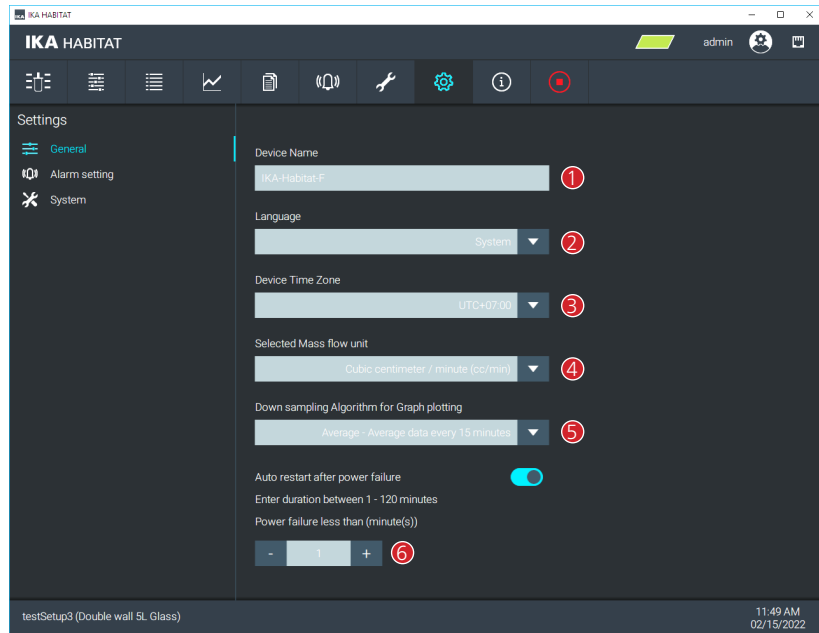

### 2.12.2 Alarm setting

- ① Enable / Disable alarm limits
- ② Lower limit: If the actual value is lower than the lower limit, an alarm will be triggered.
- ③ Higher limit: If the actual value is higher than the higher limit, an alarm will be triggered.

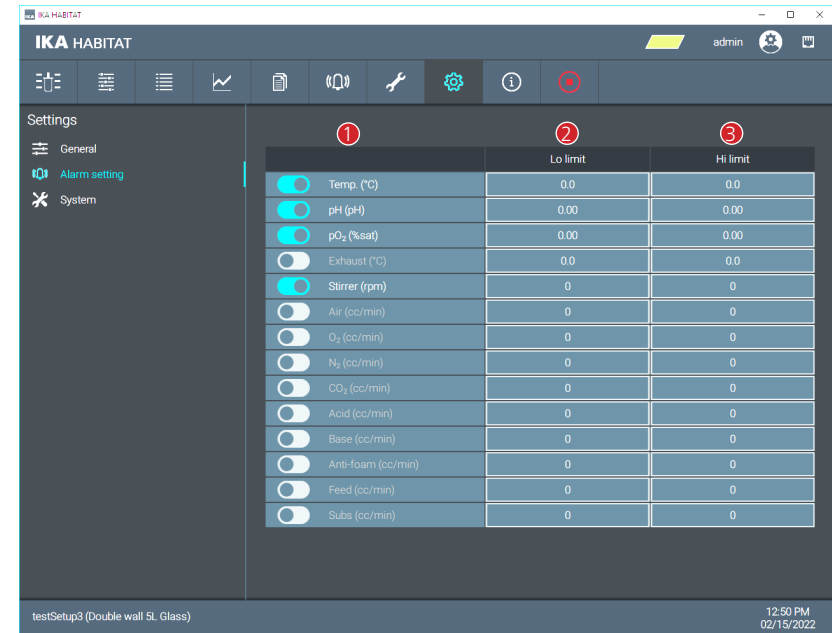

### 2.12.3 System

#### ⚠ Notice!

- › This section should be used carefully!
  - › The menu allows to change the system parameters, delete or restore configurations that may not be compatible with the device!
  - › Access to this menu is reserved for Admin Level users!
  - › However, some menus require IKA service permissions with a service password to access and change the parameters.
- ① Restore factory default configuration.
  - ② Export the current JSON file.
  - ③ Import a JSON file and upload new device configurations.
  - ④ This function is only for IKA Service.
  - ⑤ This function is only for IKA Service.
  - ⑥ Change the device type.  
Only for IKA Service!  
The changing of the device type is necessary if new device components or PCBs have been added.
  - ⑦ This function is only for IKA Service.
  - ⑧ This function is only for IKA Service.
  - ⑨ This function is only for IKA Service.
  - ⑩ This function is only for IKA Service.
  - ⑪ This function is only for IKA Service.

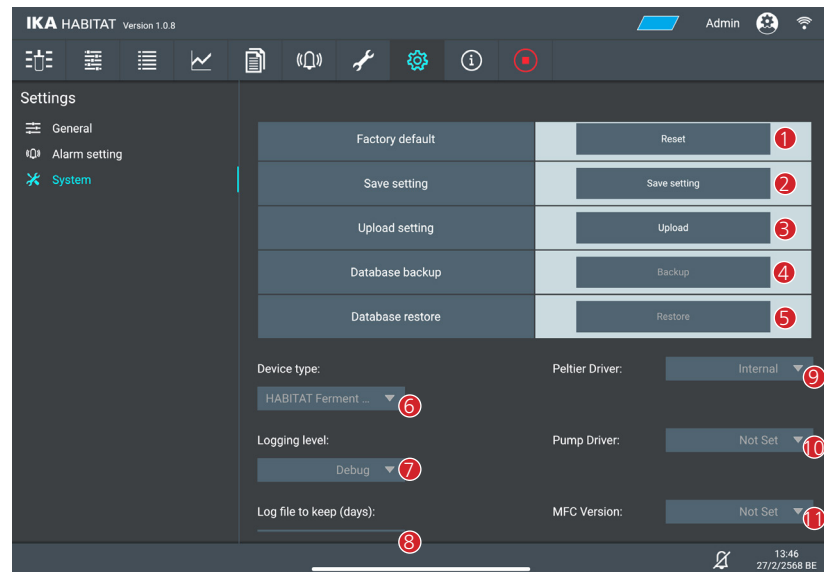

### 2.13 Info Menu

- ① About: HABITAT device information
- ② IKA Cloud: Registration information for the IKA cloud
- ③ Manual: Open HABITAT operating instructions
- ④ Video Users guides: Link to YouTube Tutorial Videos
- ⑤ Shop: Link to HABITAT product page on IKA homepage

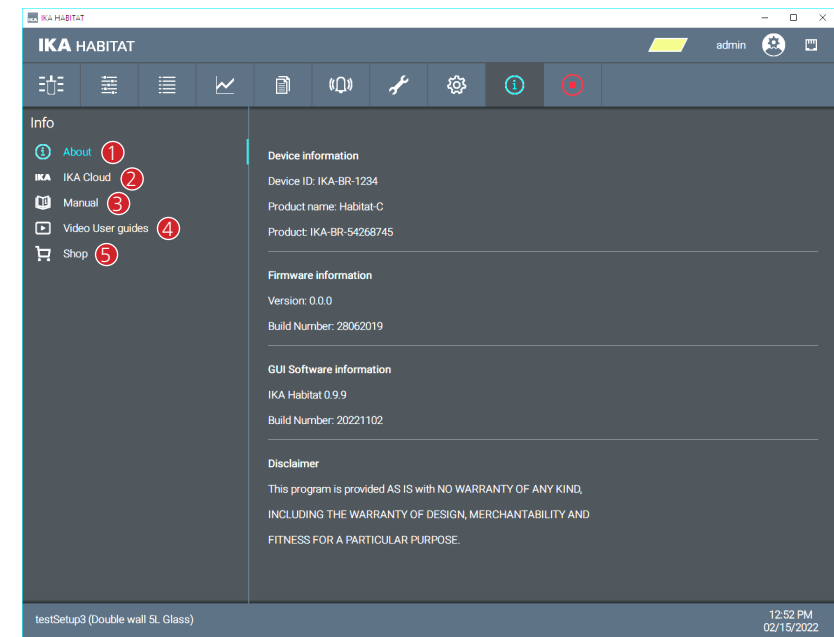

2.14 How to export cultivation data from HABITAT Control Tower?

2.14.1 During cultivation: Trends view tab

- ① Export \*.csv file to the control device (iPad/Tablet/Laptop)
- ② Export \*.csv file directly to the USB drive

The screenshot shows the IKA HABITAT interface with various parameters like Temp (26.1), pH (6.98), pO<sub>2</sub> (121.34), and Stirrer (501). A red box highlights the 'Export D...' button. Below the trends graph, a table lists experiment files. An inset image shows a USB drive plugged into the control tower, with a red circle and '2' indicating the export location.

#	Start date	Name	Recipe	Operator	status
124	19:00:13 18/01/2024	RDtest auto DO 18jan24 02	DO-ZACH	admin	Finished
123	18:48:42 18/01/2024	RDtest auto DO 18jan24	DO-ZACH	admin	Finished
122	18:02:51 18/01/2024	RD test auto DO ZACH	DO-ZACH	admin	Finished
121	17:57:51 18/01/2024	RD test auto DO	STD:ALL	admin	Finished
120	20:31:38 03/01/2024	test pump profile 02	ProfilePump	admin	Finished
119	20:15:36 03/01/2024	test pump profile 01	ProfilePump	admin	Finished
118	20:09:39 03/01/2024	test pump profile	DW-2L-default	admin	Finished
117	16:36:09 19/12/2023	Test Gravimetric profile	DW-2L-default	admin	Finished

2.14.2. Finished cultivation: Historical tab

- ① "Export to CSV" (CSV file, to iPad/Tablet/Laptop)

The screenshot shows the historical data tab with a table of experiment files. A red box highlights the 'Export to CSV' button. The table below is a detailed log of cultivation parameters over time.

#	Start date	Name	Recipe	Operator	status
124	19:00:13 18/01/2024	RDtest auto DO 18jan24 02	DO-ZACH	admin	Finished
123	18:48:42 18/01/2024	RDtest auto DO 18jan24	DO-ZACH	admin	Finished
122	18:02:51 18/01/2024	RD test auto DO ZACH	DO-ZACH	admin	Finished
121	17:57:51 18/01/2024	RD test auto DO	STD:ALL	admin	Finished
120	20:31:38 03/01/2024	test pump profile 02	ProfilePump	admin	Finished
119	20:15:36 03/01/2024	test pump profile 01	ProfilePump	admin	Finished
118	20:09:39 03/01/2024	test pump profile	DW-2L-default	admin	Finished
117	16:36:09 19/12/2023	Test Gravimetric profile	DW-2L-default	admin	Finished

- ② "Generate report" (PDF file, to iPad/Tablet/Laptop)

The screenshot shows the IKA HABITAT interface with a trends graph and a table of experiment files. A red box highlights the 'Generate report' button.

#	Start date	Name	Recipe	Operator	status
124	19:00:13 18/01/2024	RDtest auto DO 18jan24 02	DO-ZACH	admin	Finished
123	18:48:42 18/01/2024	RDtest auto DO 18jan24	DO-ZACH	admin	Finished
122	18:02:51 18/01/2024	RD test auto DO ZACH	DO-ZACH	admin	Finished
121	17:57:51 18/01/2024	RD test auto DO	STD:ALL	admin	Finished
120	20:31:38 03/01/2024	test pump profile 02	ProfilePump	admin	Finished
119	20:15:36 03/01/2024	test pump profile 01	ProfilePump	admin	Finished
118	20:09:39 03/01/2024	test pump profile	DW-2L-default	admin	Finished
117	16:36:09 19/12/2023	Test Gravimetric profile	DW-2L-default	admin	Finished

The screenshot shows a PDF report titled 'IKA Habitat - Batch Report'. It includes the IKA logo and the text 'designed for scientists'. The report details for experiment 122 are as follows:

**/// RD test auto DO ZACH**

ID: 122	Author: admin	Recipe: DO-ZACH
Initialize date: Jan 18, 2024 - 18:02:51	Start date: Jan 18, 2024 - 18:36:29	Stop date: Jan 18, 2024 - 18:37:25
Initialize time (dd:hh:mm): 00:00:33	Cultivation time (dd:hh:mm): 00:00:00	Status: Finished
Device Serial number: 990000002	Device Firmware version: 2.0.9	GUI Software version: 1.0.6

Below the report details is a 'Trend chart' showing various parameters over time, and a section for 'Further Information'.

③ "Save to USB drive" (CSV file, to USB drive)

The screenshot shows the IKA HABITAT software interface. At the top, there's a navigation bar with icons for home, list, settings, and a red stop button. Below is a large graph displaying various parameters over time: Stirrer (blue), Temp (red), pH (green), pO2 (purple), Air (yellow), O2 (cyan), CO2 (magenta), Acid (dark green), Base (orange), Anti-foam (light blue), Feed (dark blue), and Light (pink). The x-axis shows dates from Jan 18, 18:03 to Jan 18, 18:37. Below the graph is a table of experiment files:

#	Start date	Name	Recipe	Operator	status	
124	19:00:13 18/01/2024	RDtest auto DO 18jan24 02	DO-ZACH	admin	Finished	
123	18:48:42 18/01/2024	RDtest auto DO 18jan24	DO-ZACH	admin	Finished	
122	18:02:51 18/01/2024	RD test auto DO ZACH	DO-ZACH	admin	Finished	Save to USB drive
121	17:57:51 18/01/2024	RD test auto DO	STD-ALL	admin	Finished	
120	20:31:38 03/01/2024	test pump profile 02	ProfilePump	admin	Finished	
119	20:15:36 03/01/2024	test pump profile 01	ProfilePump	admin	Finished	
118	20:09:39 03/01/2024	test pump profile	DW-2L-default	admin	Finished	
117	16:36:09 19/12/2023	Test Gravimetric profile	DW-2L-default	admin	Finished	

Below the table is a large data grid with columns for various parameters and a 'Save to USB drive' icon circled in red. To the right, a close-up photo shows a USB drive plugged into the device's port.

2.15 How to save the cultivation data to iPad?

- ① Select the experiment file on the History page.
- ② Click on "Export to CSV" or "Generate report".
- ③ Wait until the file is completely exported to iPad.
- ④ Click on the "Share" icon.
- ⑤ Click on "Save to files"

The screenshot shows the IKA HABITAT software interface. At the top, there's a navigation bar with icons for home, list, settings, and a red stop button. Below is a large graph displaying various parameters over time: Stirrer (blue), Temp (red), pH (green), pO2 (purple), Air (yellow), O2 (cyan), CO2 (magenta), Acid (dark green), Base (orange), Anti-foam (light blue), Feed (dark blue), and Light (pink). The x-axis shows dates from Sep 16, 10:34 to Sep 16, 13:40. Below the graph is a table of experiment files:

#	Start date	Name	Recipe	Operator	status	
29	09:13:33 27/09/2024	RDtest-exp-27sep	DW5L-extPump	admin	Finished	
28	17:34:00 26/09/2024	RDtest-extpump-26sep-02	DW5L-extPump	admin	Finished	
27	11:32:30 26/09/2024	RDtest-extpump-26sep	DW5L-extPump	admin	Finished	
26	16:23:22 19/09/2024	RDtest-exp-19sep	DW5L-extPump	admin	Finished	
25	19:41:10 18/09/2024	RDtest-exp-18sep	DW5L-extPump	admin	Finished	
24	16:05:40 18/09/2024	RDtest-PID-THM	SW2L-PID-THM	admin	Finished	
23	10:34:01 16/09/2024	RDTest-autoDO-16sep	SW2L-PID-THM	admin	Finished	Share
22	16:16:37 13/09/2024	RDtest13sep-autoDO	SW-2L-default	admin	Finished	

Below the table is a large data grid with columns for various parameters and a 'Share' icon circled in red. The interface is overlaid with an iPad's sharing menu, showing options like AirDrop, Messages, Mail, Notes, Copy, Print, Add Tags, Save to Files (circled in red), and SAVE TO ES File Explorer.





## /// Autoclaving



### Danger!

- > After autoclaving: Be aware of the hot surfaces!
- > During autoclaving, there must be no water in the condenser.
- HA.cn:** Fill the condenser with water only after autoclaving! For autoclaving remove the filling cap of the condenser.

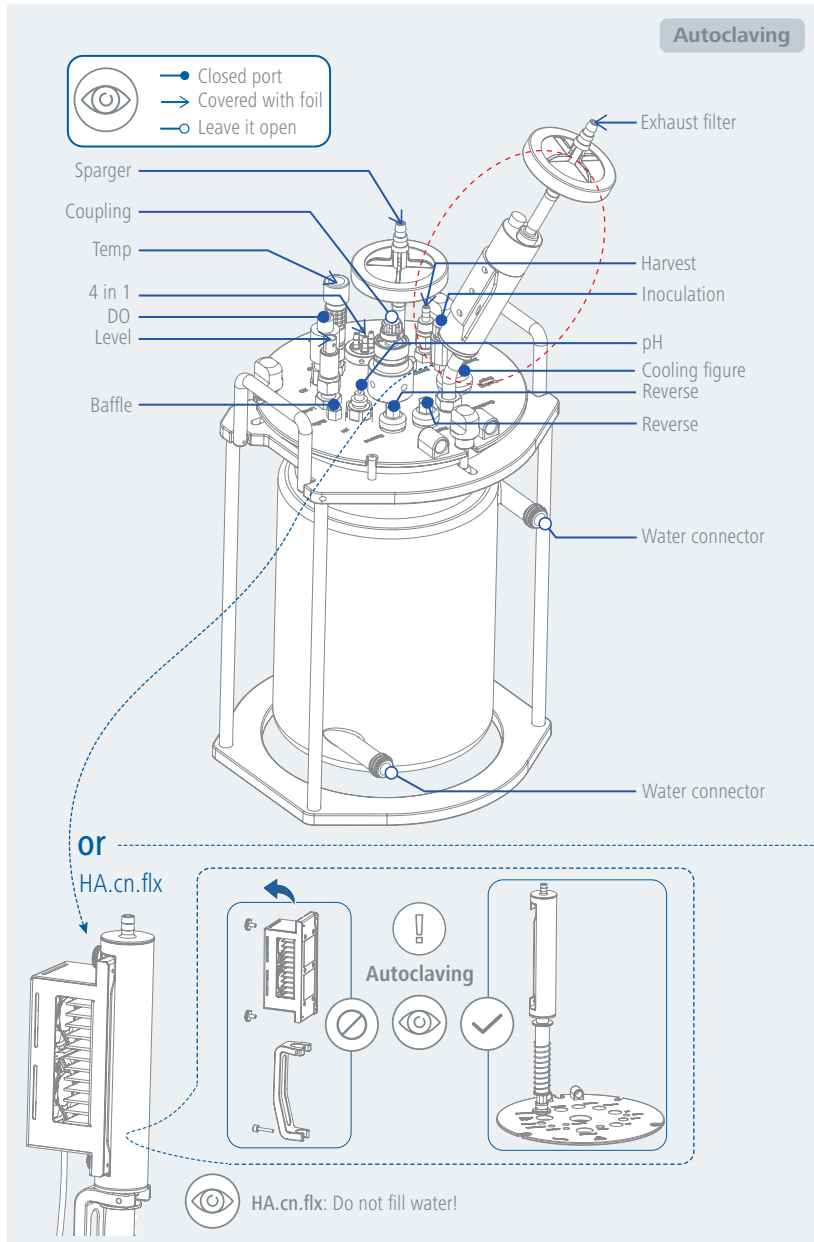

- > Before autoclaving, please remove the motor and keep the connectors of double-walled glass vessel open!
- > During autoclaving, there must be no water in the condenser. Fill the condenser with water only after autoclaving! For autoclaving remove the filling cap of the condenser.

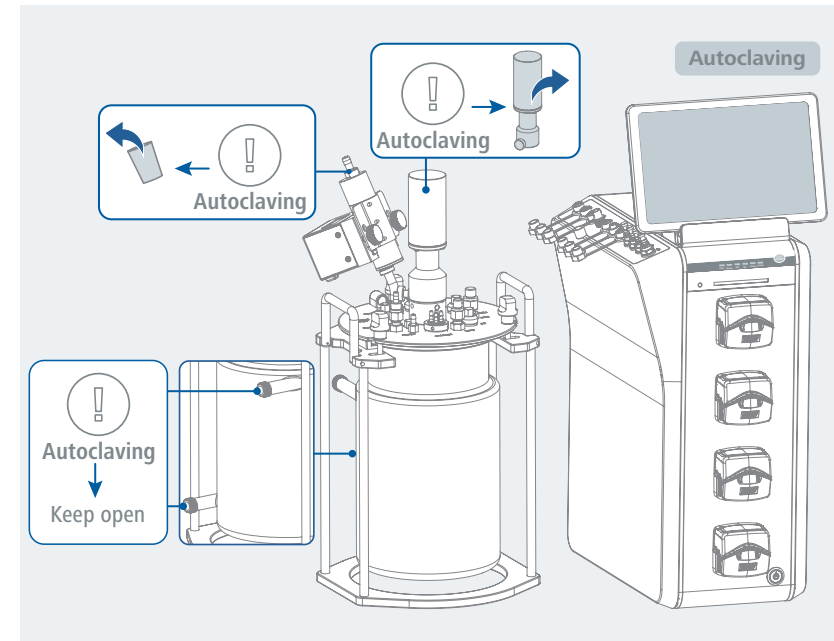

### Caution!

- > Check that the reactor vessel fits the autoclave device!
- > Avoid overpressure in the system during autoclaving!
- > Keep at least one connection port on the lid open during autoclaving!
- > Keep the exhaust filters open.
- > For double-walled reactor vessels, keep the water connections of the double jacket open!

### Steps for autoclaving

- > Place the reactor vessel in the reactor vessel stand, and then close and fasten the lid!
- > Mount the components / sensors to the lid.
- > Fill medium into the reactor vessel (if you use a double-walled reactor, do not fill water into the double jacket).
- > Remove the sensor cables.
- > Remove the motor.
- > Close the caps to protect the sensor connectors.
- > Cover the sensor connections.
- > Use caps, clamps or aluminium foil to cover the connections.
- > Carry the reactor vessel only by the carrying handles on the reactor vessel stand!
- > Place the reactor vessel with the reactor vessel stand in the autoclave (e.g. 25 ... 30 minutes at 121 °C, liquid cycle).
- > After autoclaving, wait until the system cools down.

### /// Inoculation

- › Blow torch flame over the coupling to sterilize again before opening it for inoculation.
- › There are different options for the inoculation:
  - Use a syringe and the septum port. Pierce the syringe needle through the septum port.
  - Open the port and add the liquid directly under the laminar flow hood.

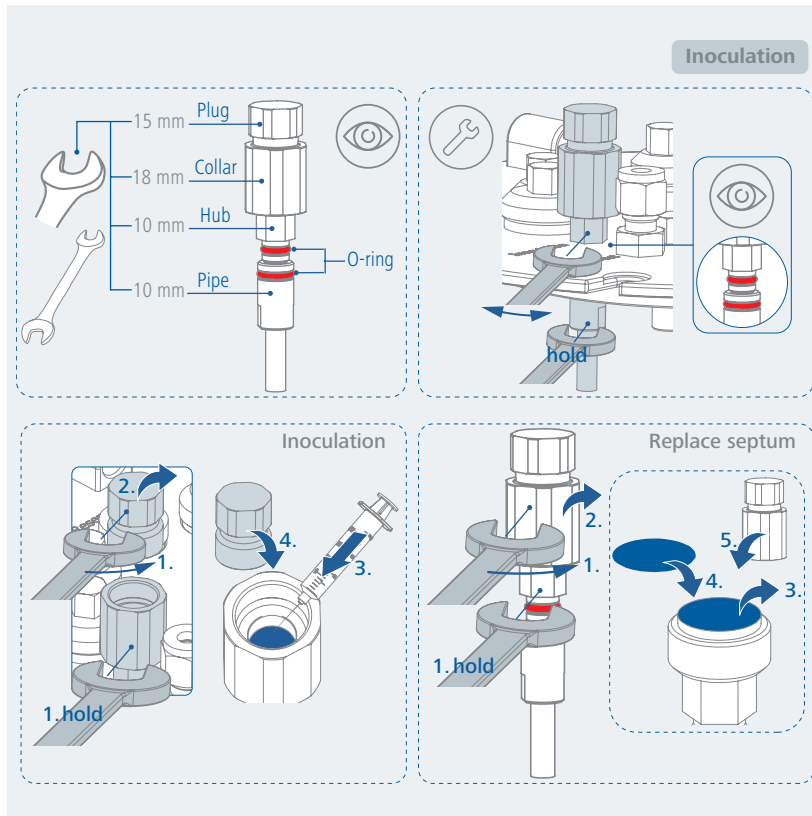

### /// Harvesting

- › There are different methods for harvesting or emptying the reactor vessels:
  - Direct pouring into an empty vessel or transferring to another vessel under the laminar flow hood.
  - Connect the sterilized silicone tubing to the harvesting tube and pump it into a prepared container using the peristaltic pump. This method is recommended for the viscous cell.
  - Apply overpressure to the vessel. This method can be used if the harvesting hose is used. First, clamp the hose to block the escaping gas. Then turn on the gas flow system (maximum pressure 1.5 bar) and slowly adjust the flow rate.

### /// Sampling

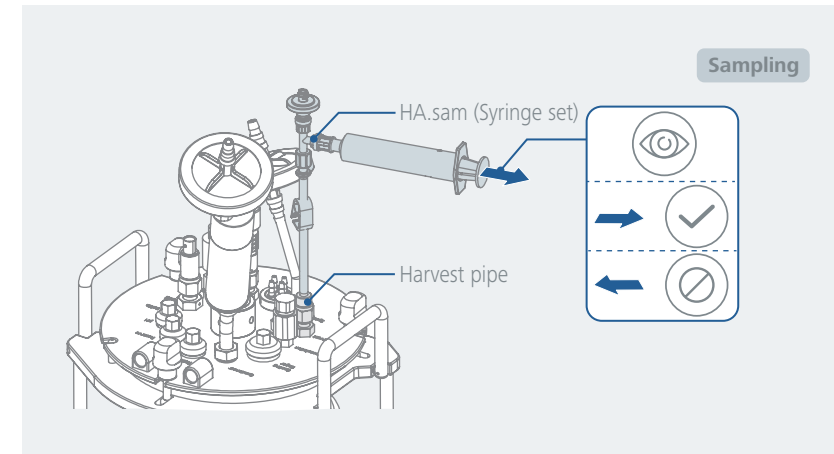

## Interfaces and outputs

The device can be operated by computer via an RS 232 or USB port using labworldsoft® laboratory software.

The device software can also be updated with a PC via the RS 232 or USB port.

**Note:** Please comply with the system requirements together with the operating instructions and help section included with the software.

### /// USB interface

The Universal Serial Bus (USB) is a serial bus for connecting the device to the PC. Equipped with USB devices can be connected to a PC during operation (hot plugging). Connected devices and their properties are automatically recognized. The USB port can also be used to update firmware.

### /// USB device drivers

First, download the latest driver for IKA devices with USB port from:

<https://www.ika.com/ika/lws/download/usb-driver.zip>

Install the driver by running the setup file. Connect the IKA device through the USB data cable to the PC. The data communication runs through a virtual COM port.

**Note:** The USB driver is unnecessary for Windows 10 system. Don't install it for Windows 10 system!

### /// RS 232 interface

Configuration

- › The functions of the interface connections between the device and the automation system are chosen from the signals specified in EIA standard RS 232 in accordance with DIN 66 020 Part 1.
- › For the electrical characteristics of the interface and the allocation of signal status, standard RS 232 applies in accordance with DIN 66 259 Part 1.
- › Transmission procedure: asynchronous character transmission in start-stop mode.
- › Type of transmission: full duplex.
- › Character format: character representation in accordance with data format in DIN 66 022 for start-stop mode. 1 start bit; 7 character bits; 1 parity bit (even); 1 stop bit.
- › Transmission speed: 9600 bit/s.
- › Data flow control: none
- › Access procedure: data transfer from the device to the computer takes place only at the computer's request.

### /// Connection between the device and the external devices

- › PC 1.1 Cable: This cable is required to connect RS 232 port to a PC.

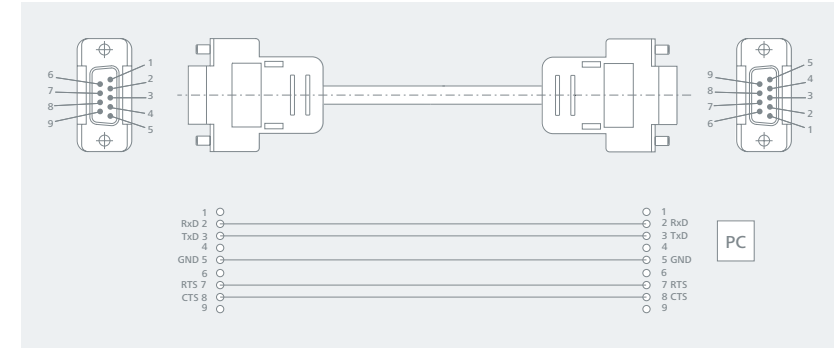

- › USB Cable A – B: This cable is required to connect USB port to a PC.

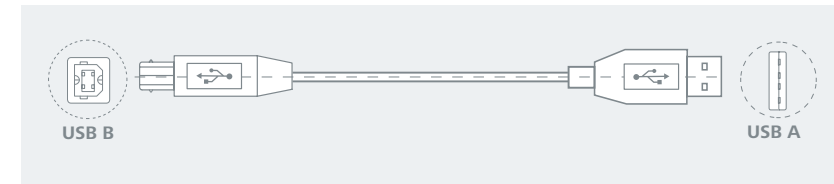

### /// Connection capability

- › Wi-Fi®

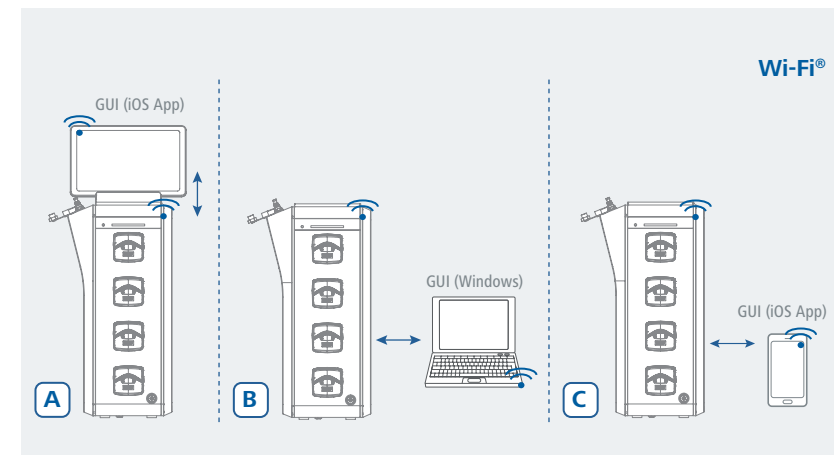

> RS 232 / USB

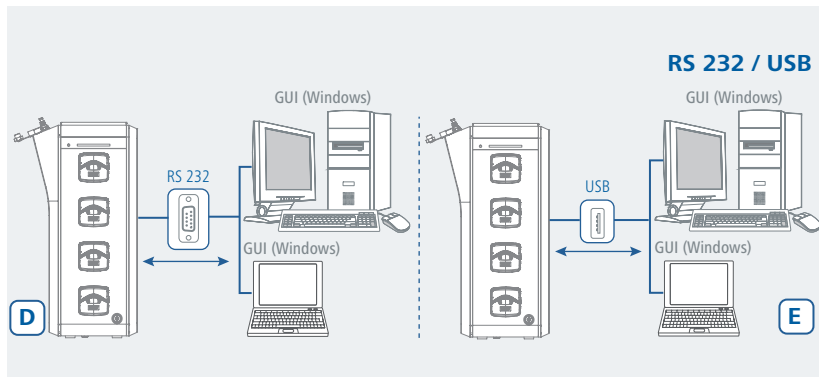

> Ethernet

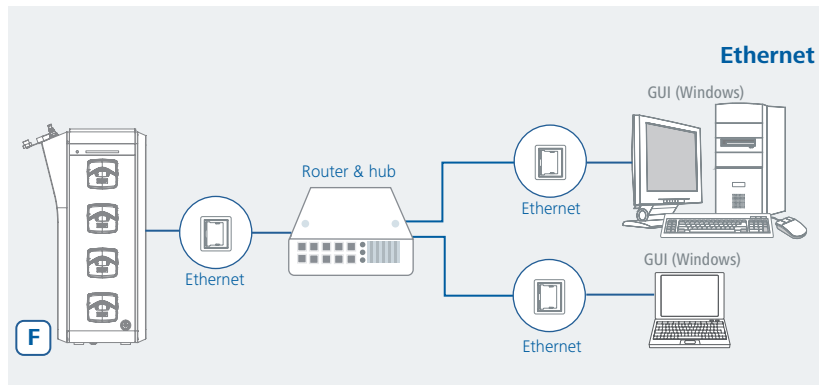

> Ethernet + Wi-Fi®

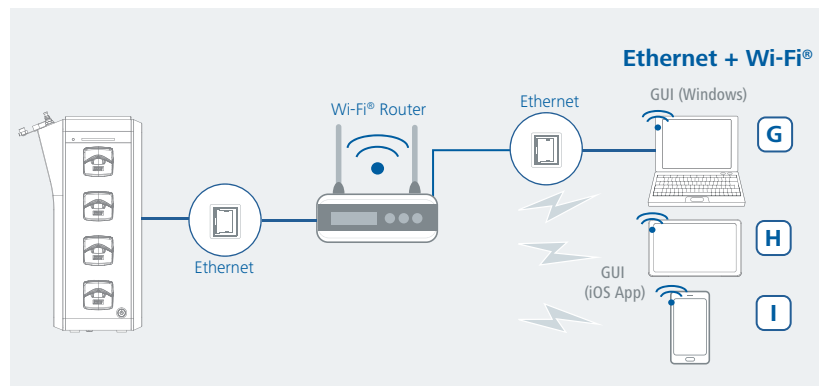

> Remote

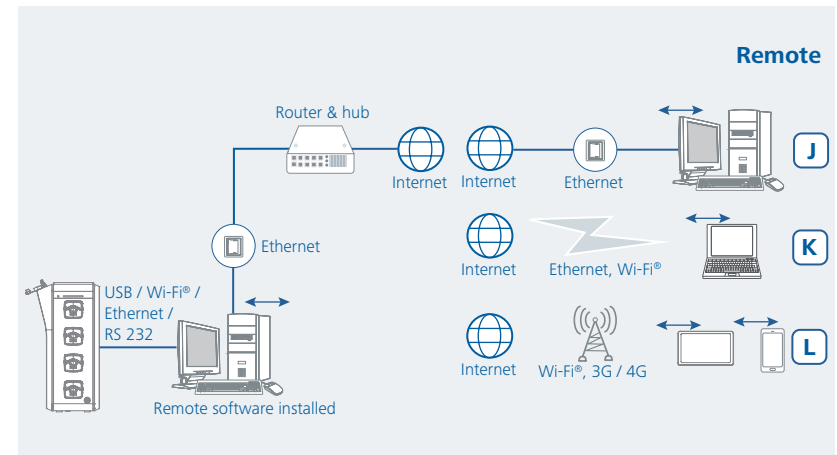

> VPN

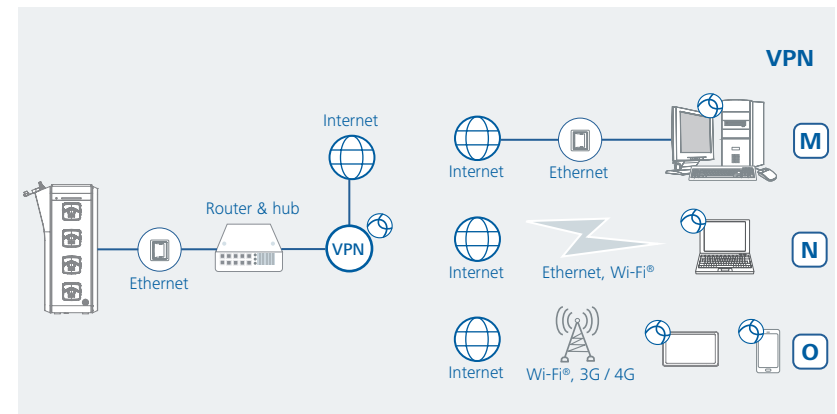

> IKA Cloud

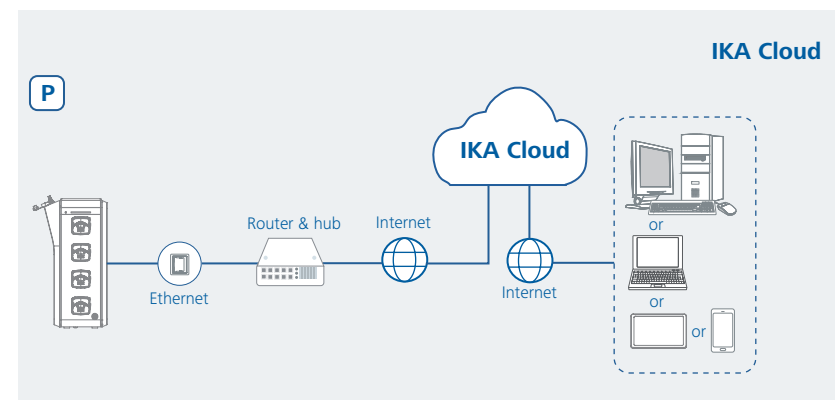

## Maintenance and cleaning

### /// Maintenance Checklist

Component	Check	Before use	Note
Reactor vessel	Visual inspection	X	<ul style="list-style-type: none"> <li>› Don't use if there are any visible cracks or damages</li> <li>› Replace if necessary</li> </ul>
Hoses (gas & liquids)	Visual inspection	X	<ul style="list-style-type: none"> <li>› Don't use if there are any visible cracks or damages</li> <li>› Replace if necessary</li> </ul>
Electrical components (Motor, Heating jacket, Sensors...)	Visual inspection	X	<ul style="list-style-type: none"> <li>› Don't use if there are any visible cracks or damages</li> <li>› Replace if necessary</li> </ul>
Sealings, O-Rings (connectors and stirrer shaft coupling)	Visual inspection	X	<ul style="list-style-type: none"> <li>› Don't use if there are any visible cracks or damages</li> <li>› Replace if necessary</li> </ul>
Filters	Visual inspection	X	<ul style="list-style-type: none"> <li>› Don't use if there are any visible cracks or damages</li> <li>› Replace if necessary</li> </ul>
Other components made of glass	Visual inspection	X	<ul style="list-style-type: none"> <li>› Don't use if there are any visible cracks or damages</li> <li>› Replace if necessary</li> </ul>
pH- and DO- sensors	Visual inspection Calibration	X	<ul style="list-style-type: none"> <li>› Don't use if there are any visible cracks or damages</li> <li>› Replace if necessary</li> <li>› Refer to software, use calibration guide</li> </ul>
Foam- and Level- sensors	Adjust sensitivity	X	

### /// Cleaning

- › For cleaning disconnect the mains plug!
- › Use only cleaning agents which have been approved by IKA to clean IKA devices: Water containing surfactant / isopropyl alcohol.
- › Wear protective gloves during cleaning the devices.
- › Electrical devices may not be placed in the cleansing agent for the purpose of cleaning.
- › Do not allow moisture to get into the device when cleaning.
- › Before using another than the recommended method for cleaning or decontamination, the user must ascertain with IKA that this method does not destroy the device.
- › For parts in contact with medium, please take them for the autoclaving after the cleaning!

### /// Ordering spare parts

- › When ordering spare parts, please give:
  - device type.
  - serial number, see type plate.
  - position number and description of spare part, see [www.ika.com](http://www.ika.com).
  - software version.

### /// Repairs

- › Please only send devices in for repair that have been cleaned and are free of materials which might present health hazards.
- › For repair, please request the "**Safety Declaration (Decontamination Certificate)**" from IKA or use the download printout of it from IKA website at [www.ika.com](http://www.ika.com).
- › If your appliance requires repair, return it in its original packaging. Storage packaging is not sufficient when sending the device - also use appropriate transport packaging.

## Accessories

- › For accessories see [www.ika.com](http://www.ika.com).

## Error codes

### /// Table "Error codes"

- › The fault is shown by an error code on the display as following if the error occurs.  
Proceed as follows in such cases:
  - Turn off the device by using the mains switch.
  - Carry out corrective measures.
  - Restart the device.

#### Error code | Causes | Effect | Solutions

##### 01290009 - Power Supply shutdown

Causes	› AC Power failure
Effect	› Device stops
Solutions	› Check the AC power supply › Check the fuses › Contact customer service

##### 01380615 - Stirring contact disconnected

Causes	› No signal from motor
Effect	› Stirrer off
Solutions	› Check the motor cable › Check the motor › Contact customer service

##### 01383610 - Stirring Speed blocked

Causes	› Motor does not run
Effect	› Stirrer motor off
Solutions	› Check the cable connection › Check the sensor › Contact customer service

##### 01392915 - Temperature Sensor disconnected

Causes	› No signal from sensor
Effect	› Display 0.0 › Temperature control is not active
Solutions	› Check the cable connection › Check the sensor › Contact customer service

##### 01072915 - Dissolved Oxygen (DO) Sensor disconnected

Causes	› No signal from sensor
Effect	› Display 0.0 › DO control is not active
Solutions	› Check the cable connection › Check the sensor › Contact customer service

##### 01132915 - Foam Sensor disconnected

Causes	› No signal from sensor
Effect	› Foam control is not active
Solutions	› Check the cable connection › Check the sensor › Contact customer service

##### 01172915 - Level Sensor disconnected

Causes	› No signal from sensor
Effect	› Level control is not active
Solutions	› Check the cable connection › Check the sensor › Contact customer service

##### 01140615 - Heater contact disconnected

Causes	› No signal from Heater
Effect	› Heater off
Solutions	› Check the heater cable › Check the heater › Contact customer service

##### 01090615 - Exhaust (Filter Heater) contact disconnected

Causes	› No signal from Filter heater
Effect	› Filter heater off
Solutions	› Check the filter heater cable › Check the filter heater › Contact customer service

##### 01011315 - Air Flow disconnected

Causes	› No gas input
Effect	› Air control is not active
Solutions	› Check the gas supply and tubing › Contact customer service

##### 01261315 - Oxygen (O<sub>2</sub>) Flow disconnected

Causes	› No gas input
Effect	› O <sub>2</sub> control is not active
Solutions	› Check the gas supply and tubing › Contact customer service

##### 01021315 - Carbon dioxide (CO<sub>2</sub>) Flow disconnected

Causes	› No gas input
Effect	› CO <sub>2</sub> control is not active
Solutions	› Check the gas supply and tubing › Contact customer service

##### 01251315 - Nitrogen (N<sub>2</sub>) Flow disconnected

Causes	› No gas input
Effect	› N <sub>2</sub> control is not active.
Solutions	› Check the gas supply and tubing › Contact customer service

##### 01563610 - Pump A Speed blocked

Causes	› Pump A does not run
Effect	› Pump A stops
Solutions	› Visual inspection of the pump head › Open the pump head and perform a test › Contact customer service

### 01573610 - Pump B Speed blocked

Causes	> Pump B does not run
Effect	> Pump B stops
Solutions	> Visual inspection of the pump head > Open the pump head and perform a test > Contact customer service

### 01583610 - Pump C Speed blocked

Causes	> Pump C does not run
Effect	> Pump C stops
Solutions	> Visual inspection of the pump head > Open the pump head and perform a test > Contact customer service

### 01593610 - Pump D Speed blocked

Causes	> Pump D does not run
Effect	> Pump D stops
Solutions	> Visual inspection of the pump head > Open the pump head and perform a test > Contact customer service

- > If the actions described fails to resolve the fault or another error code is displayed:
  - Contact the service department.
  - Send the device for repair, including a short description of the fault.

## /// LED Status

### 1. Processing Status

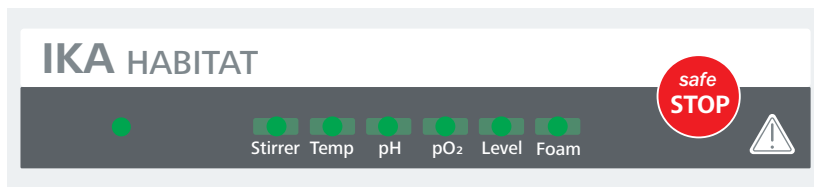

#### 1.1 Stirrer

##### 1.1.1 Color status:

- > **GREEN:** Stirrer is working normally.
- > **ORANGE:** Warning, actual value out of the alarm limits
- > **RED:** An error has occurred.
- > **OFF:** Stirrer motor cable is not connected.

##### 1.1.2 Possible Error codes:

- > 01380615: Stirring contact disconnected / Check the motor and the motor cable.
- > 01383610: Stirring Speed blocked / Check the motor and the drive shaft.
- > 01382708: Stirring Safety Circuit safety circuit cut-off / Contact customer service.
- > 01383502: Stirring Setting upper limit / Check the alarm setting.
- > 01383503: Stirring Setting lower limit / Check the alarm setting.

#### 1.2 Temp

##### 1.2.1 Color status:

- > **GREEN:** Temperature control is working normally.
- > **ORANGE:** Warning, actual value out of the alarm limits
- > **RED:** An error has occurred.
- > **OFF:** Temperature sensor cable is not connected.

##### 1.2.2 Possible Error codes:

- > 01392915: Temperature Sensor disconnected / Check the temperature sensor and the cable.
- > 01393502: Temperature Setting upper limit / Check the alarm setting.
- > 01393503: Temperature Setting lower limit / Check the alarm setting.
- > 01140615: Heater contact disconnected / Check the heat blanket and the cable
- > 01142920: Heater Sensor fault / Contact customer service.
- > 01143808: Heater Temperature safety circuit cut-off / Contact customer service.
- > 01143824: Heater Temperature too high / Check the installation of the heat blanket on the vessel.

#### 1.3 pH

##### 1.3.1 Color status:

- > **GREEN:** pH control is working normally.
- > **ORANGE:** Warning, actual value out of the alarm limits
- > **RED:** An error has occurred.

##### 1.3.2 Possible Error codes:

- > 01283502: pH Setting upper limit / Check the alarm setting.
- > 01283503: pH Setting lower limit / Check the alarm setting.

#### 1.4 pO<sub>2</sub>

##### 1.4.1 Color status:

- > **GREEN:** pO<sub>2</sub> control is working normally.
- > **ORANGE:** Warning, actual value out of the alarm limits
- > **RED:** An error has occurred.
- > **OFF:** DO sensor cable is not connected.

##### 1.4.2 Possible Error codes:

- > 01072915: Dissolved Oxygen (DO) Sensor disconnected / Check DO probe and cable.
- > 01073502: Dissolved Oxygen (DO) Setting upper limit / Check the alarm setting.
- > 01073503: Dissolved Oxygen (DO) Setting lower limit / Check the alarm setting.

#### 1.5 Level

##### 1.5.1 Color status:

- > **GREEN:** Level is normal
- > **RED:** Level (max.) is reached
- > **OFF:** Foam & Level sensor box is not connected.

##### 1.5.2 Possible Error codes:

- > 01172915: Level Sensor disconnected / Check the cable connection to the control unit.
- > 01172906: Level Sensor set value exceeded / Liquid has been detected by the sensor.

#### 1.6 Foam

##### 1.6.1 Color status:

- > **GREEN:** Foaming is normal, within the detection area.
- > **RED:** Foam has been detected.
- > **OFF:** Foam & Level sensor box is not connected.

##### 1.6.2 Possible Error codes:

- > 01132915: Foam Sensor disconnected / Check the cable connection to the control unit.
- > 01132906: Foam Sensor set value exceeded / Foam has been detected by the sensor.

- 2. Interrupting Status
- 2.1 Emergency mode display
- > All 6 LEDs keep flashing in "RED"

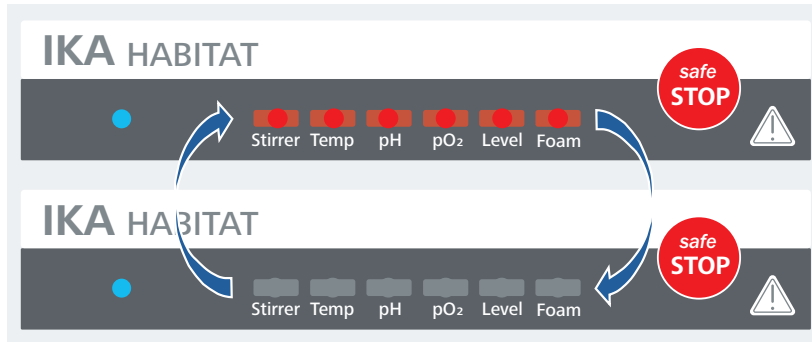

- 2.2 Wi-Fi® reset and initialization display
- 2.21 Triple LED (left -right) are flashing in "GREEN" during Wi-Fi® module reset and connection setup
- 2.22 Setup finished. Ready for Wi-Fi® connection.

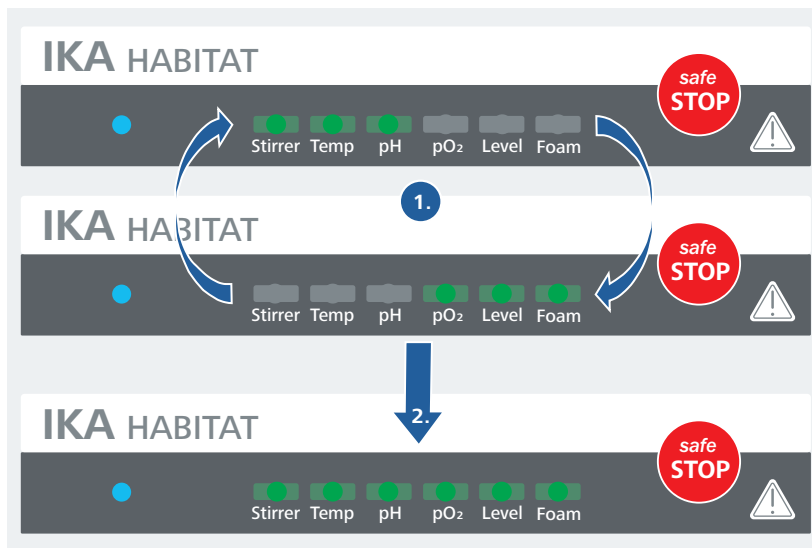

## Technical data



Environment	
Permissible ambient temperature	+ 5 ... + 40 °C
Permissible relative humidity	80% (up to 31 °C), decreasing linearly to max. 50 (@40 °C)
Permitted on-time	100 %
Protection class	I
Contamination level	2
Overvoltage category	II
Operation at a terrestrial altitude	max. 2000 m
Control unit	
Nominal voltage	100 ... 240 VAC
Frequency	50 / 60 Hz
Max. rated power	1100W
Nominal input power	300 W
Fuse	2x T5.0 A 250 V
Dimensions (W x D x H)	224 x 405 x 624 mm
Dimension (W x D)	189 x 345 mm
Material of housing	Metal housing and PUR coated
Weight	14 kg
Protection class according to DIN EN 60529	IP 20
Motor direct coupling	0.25L glass 1...2000 rpm 0.5 L glass 1...1400 rpm 1 L glass: 1 ... 2000 rpm 2 L glass: 1 ... 2200 rpm 5 L glass: 1 ... 1500 rpm 10 L glass: 1 ... 800 rpm 3.0 L SU: 1 ... 400 rpm
System requirement	Window 10 or higher iOS 7 or higher
Interface	USB PC connect RS 232 Ethernet SU connect Thermostat Ext. pump Ext. signal input 4 ... 20 mA

Pump Module	
Quantity	4 PC
Controller	Variable speed (CW / CCW)
Flow rate (Tube wall thickness 1.6 mm)	ID 0.5 mm: 0.3 ... 4 cc/min ID 0.8 mm: 1.0 ... 12 cc/min ID 1.2 mm: 1.6 ... 20 cc/min ID 1.6 mm: 3.0 ... 45 cc/min ID 2.4 mm: 7.0 ... 85 cc/min ID 3.2 mm: 13.3 ... 140 cc/min ID 4.8 mm: 26.6 ... 270 cc/min
Probe and controllers * is optional	
Temperature	0 ... 100 °C Display resolution: 0.1 °C
DO probe (Brand Hamilton)	Range 0 ... 200 % Display resolution: 0.01 %
pH probe (Brand Hamilton)	Range 0 ... 14 pH Display resolution: 0.01 pH
Foam	Display: Norm. or Act.
Level	Display: Norm. or Act.
*CO <sub>2</sub>	Range 0 ... 100 % Display resolution: 0.01 %
*Conductivity	Range 0.2 ... 400 ms/cm Accuracy ± 5%
*Turbidity	Range 0 ... 250 g/L Range 10 ... 4000 FTU
Aeration Module	
Gas inlet	- Dry and oil free gases - Maximum pressure 3.0 barg ±10 %
Gas outlet	- Maximum pressure 1.0 barg With safety relief valve 1.0 bar
Four gases system (Air, O <sub>2</sub> , N <sub>2</sub> & CO <sub>2</sub> ) for Cell culture Automatic aeration control	
Cell culture flow rate	10 ... 2000 cc/min
Fermentation flow rate	100 ... 20000 cc/min
Accuracy	±2% full scale
Temp control module in side vessel	
Using heating jacket (single wall vessel)	Room temp ... 60 °C
Using chiller (double wall vessel)	5 ... 80 °C
LED light panel	
Type	Flexible LED panel system, able to adjust brightness
Number of light panel	Up to 4
	Day & night simulation can be programmed

Vessel information							
	Unit	Glass vessel 0.25 L	Glass vessel 0.5 L	Glass vessel 1 L	Glass vessel 2 L	Glass vessel 5 L	Glass vessel 10 L
Total volume	l	0.4	0.8	1.6	3.00	6.7	12.9
Max. working volume	l	0.25	0.5	1	2	5	10
Min. working volume	l	0.06-0.08	0.25	0.30	0.60	1.0	2.0
Vessel inner diameter d <sub>v</sub>	mm	65.6	90	110	130	160	190
Vessel height h	mm	130	150	190	260	370	470
Ratio h/d <sub>v</sub>	mm	1.98	1.67	1.73	2.00	2.31	2.47
Liquid height h <sub>l</sub>	mm	78	85	110	160	265	370
Ratio h <sub>l</sub> /d <sub>v</sub>	mm	1.19	0.94	1.0	1.23	1.66	1.95
Diameter 6-blade impeller d <sub>6</sub>	mm	24	33	40	48	57	68
Diameter 3-pitch blade impeller d <sub>3</sub>	mm	25	34	41	49	59	69
Ratio d <sub>6</sub> / d <sub>v</sub> (6-blade)	mm	0.37	0.37	0.36	0.37	0.36	0.36
Ratio d <sub>3</sub> / d <sub>v</sub> (3-pitch blade)	mm	0.38	0.38	0.37	0.38	0.37	0.36
Net weight assembled without media & accessories single wall	kg	5.98	6.4	7.87	9.11	13.29	-
Net weight assembled without media & accessories double wall	kg	6.21	6.77	8.09	10.55	15.66	21.9
Weight SU 2 L without holder	kg	-	-	-	-	-	-
Weight SU 2 L with holder	kg	-	-	-	-	-	-

Overall dimension (mm)			
Vessel size	Width	Depth	Height
Glass vessel 0.25 L	875	530	510
Glass vessel 0.5 L	875	530	630
Glass vessel 1 L	900	530	630
Glass vessel 2 L	920	530	630
Glass vessel 5 L	950	530	860
Glass vessel 10 L	990	530	980

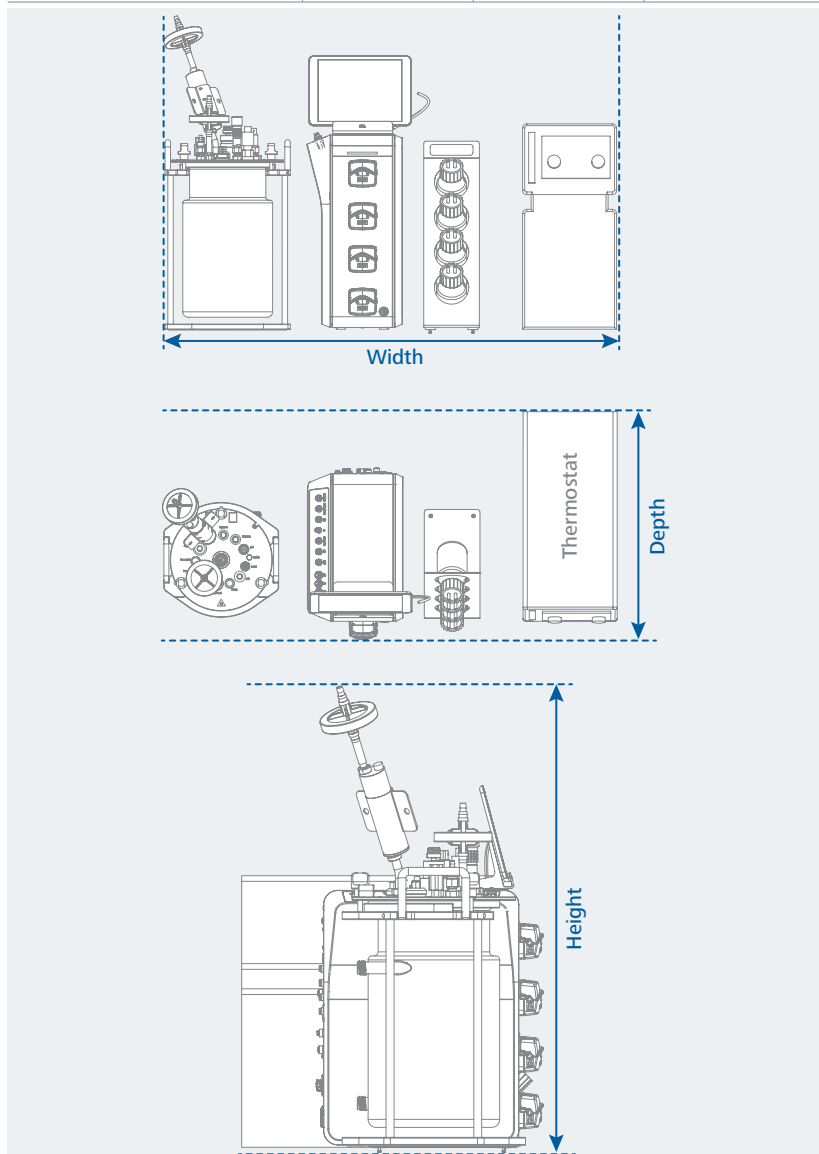

Space requirement for autoclaving (mm)			
Vessel size	Width	Depth	Height
Glass vessel 0.25 L	185	215	510
Glass vessel 0.5 L	185	215	455
Glass vessel 1 L	210	240	505
Glass vessel 2 L	230	260	580 (cell)   480 (ferment)
Glass vessel 5 L	260	290	560
Glass vessel 10 L	300	330	650

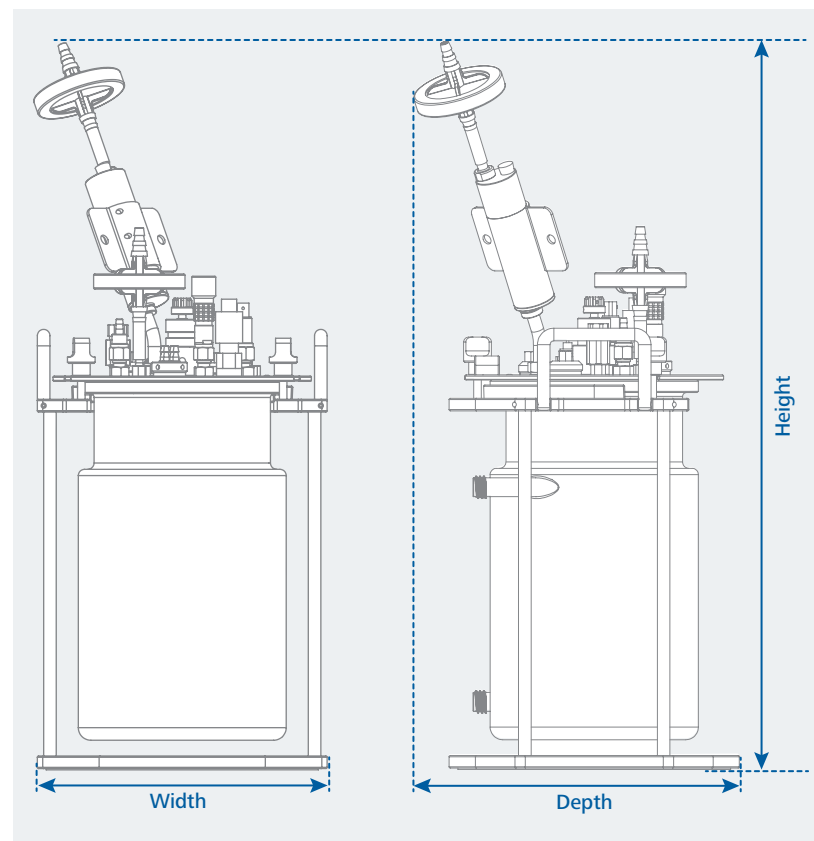

## Multiuse vessel

Material	
Vessel	Borosilicate glass 3.3
Components contact to medium	Stainless steel 316
Components not contact to medium	Stainless steel 304
Gasket	EPDM
O-ring	Silicone USP class VI

## Hose for peristaltic pump

Material	Silicone USP Class VI
Size (ID x wall THK)	3.2 x 1.6 mm

## Tube for air / gases

Material	Silicone tube USP class VI
Size (ID x OD)	3.2 x 6.4 mm

## Impeller type

Type	6-blades or 3-pitched blades
Flow characteristic	Down or up flow

## Sparger type

Micro sparger	5 micron
Ring sparger	Hole diameter 0.5 mm

## Air pump

### Specification

Voltage	115 ... 230 VAC
Rated pressure	0.15 bar
Flow rate	80 Liter / min
Noise level	40 dB

## Peltier Cooling

Type of cooling	peltier or water cooling
Temperature min. / Condenser with Peltier	15 °C
Operating mode	continuous operation
Auto restart after power failure	yes
Dimensions (W x D x H)	90 x 250 x 70 mm
Weight	2 kg
Permissible ambient temperature	+ 5 ... + 40 °C
Permissible ambient conditions	80% (up to 31 °C), decreasing linearly to max. 50% (@40 °C)
Protection class according to DIN EN 60529	IP 20
Voltage	100 ... 240 V
Frequency	50 / 60 Hz
Power input	50 W
Power input max.	60 W
Fuse	2 x T5.0A 250 V

PC requirements		
	Minimum	Recommended
Operating system	Windows 10, 32/64 bits	Windows 10, 64 bits
Processor	Intel® Core i3 8th generation (8109U) or above	Intel® Core i5 4th generation ( or an equivalent AMD processor)
Graphics card	Video adapter compatible with DirectX 9, WDDM driver support and minimum 128 MB RAM	Video adapter compatible with DirectX 10, WDDM driver support and minimum 1 GB RAM
RAM	4 GB	8 GB
Storage	HDD, minimum 15 GB free disk space	SSD, minimum 50 GB free disk space
Display	1024 x 768 (XGA)	1920 x 1080 (FHD)
Peripherals		
Ethernet	10BASE-T	Gigabit Ethernet
Wi-Fi®	802.11a/b/g/n/ac	802.11a/b/g/n/ac
WPAN	4.2	4.2
USB	USB 2.0	USB 3.0
Serial port (optional)	DB-9 connector	DB-9 connector
Tablet requirements		
	Minimum	Recommended
Operating system	Running iOS 11 or later	Running iOS 12 or later
Processor	ARM: ARMv7-A or higher	ARM: ARMv8-A or higher
RAM	2 GB	4 GB
Storage	32 GB	64 GB
Display	7 inch in diagonal, viewport ≥ 768 x 1024	10 inch in diagonal, viewport ≥ 768 x 1024
Peripherals		
Wi-Fi®	802.11a/b/g/n/ac	802.11a/b/g/n/ac
WPAN	4.2	4.2
Smart Phone requirements		
	Minimum	Recommended
Operating system	Running iOS 11 or later	Running iOS 12 or later
Processor	ARM: ARMv7-A or higher	ARM: ARMv8-A or higher
RAM	2 GB	4 GB
Storage	32 GB	64 GB
Display	5.5 inch in diagonal, viewport ≥ 380 x 640	6.0 inch in diagonal, viewport ≥ 412 x 732
Peripherals		
Wi-Fi®	802.11a/b/g/n/ac	802.11a/b/g/n/ac
WPAN	4.2	4.2

Subject to technical changes!

## Warranty

- › In accordance with IKA Terms and Conditions of Sale, the warranty period is 24 months. For claims under the warranty please contact your local dealer. You may also send the device direct to our factory, enclosing the delivery invoice and giving reasons for the claim. You will be liable for freight costs.
- › The warranty does not cover worn out parts, glassware or sensors, nor does it apply to faults resulting from improper use, insufficient care or maintenance not carried out in accordance with the instructions in this operating manual.



designed for scientists

#### **IKA-Werke GmbH & Co. KG**

Janke & Kunkel-Straße 10,  
79219 Staufen, Germany  
Phone: +49 7633 831-0  
eMail: sales@ika.de

#### **USA**

**IKA Works, Inc.**  
Phone: +1 910 452-7059  
eMail: sales@ika.net

#### **KOREA**

**IKA Korea Ltd.**  
Phone: +82 2 2136 6800  
eMail: sales-lab@ika.kr

#### **BRAZIL**

**IKA Brasil**  
Phone: +55 19 3772 9600  
eMail: sales@ika.net.br

#### **MALAYSIA**

**IKA Works (Asia) Sdn Bhd**  
Phone: +60 3 6099-5666  
eMail: sales.lab@ika.my

#### **CHINA**

**IKA Works Guangzhou**  
Phone: +86 20 8222 6771  
eMail: info@ika.cn

#### **POLAND**

**IKA Poland Sp. z o.o.**  
Phone: +48 22 201 99 79  
eMail: sales.poland@ika.com

#### **JAPAN**

**IKA Japan K.K.**  
Phone: +81 6 6730 6781  
eMail: info\_japan@ika.ne.jp

#### **INDIA**

**IKA India Private Limited**  
Phone: +91 80 26253 900  
eMail: info@ika.in

#### **UNITED KINGDOM**

**IKA England LTD.**  
Phone: +44 1865 986 162  
eMail: sales.England@ika.com

#### **VIETNAM**

**IKA Vietnam Company Limited**  
Phone: +84 28 38202142  
eMail: sales.lab-vietnam@ika.com

#### **THAILAND**

**IKA Works (Thailand) Co. Ltd.**  
Phone: +66 2059 4690  
eMail: sales.lab-thailand@ika.com

#### **TURKEY**

**IKA Turkey A.Ş.**  
Phone: +90 216 394 43 43  
eMail: sales.turkey@ika.com

#### **KENYA**

**IKA Works Kenya Ltd.**  
Phone: +254 112 323 745  
eMail: sales.kenya@ika.com

#### **UGANDA**

**IKA Works Kampala Limited**  
Phone: +254 112 323 745  
eMail: sales.uganda@ika.com

#### **SPAIN**

**IKA Works Spain, S. L.**  
**Barcelona**  
eMail: sales.spain@ika.com

Register now: [www.ika.com/register](http://www.ika.com/register)



[www.ika.com](http://www.ika.com)



IKAworlwide // #lookattheblue

Technical specifications may be changed without prior notice.