



INSTALLATION INSTRUCTIONS

Safe-Assist® Shower Seat



When safety in the shower is paramount, Con-Serv Safe-Assist® shower seats are the industry recognised solution with non-slip foldable seat, rounded edges and water drain channels.

Manufactured from grade 304 Stainless Steel, Polar White UV resistant High Density Polyethylene (HDPE) seat top and assembled with Tension Grip Hinge, ensuring stability up to 160kg. Special sizes available on request.

IMPORTANT: MUST BE FITTED TO A SOLID WALL OR OTHER FIRM SURFACE.
For fixing to timber, use only hexagon coach screws. For fixing to brickwork, block work or concrete, use the hexagon screws with 10mm wall plugs or equivalent.

Grade 304 Stainless Steel M8 x 75mm hexagon coach screws supplied and 10mm wall plugs supplied.

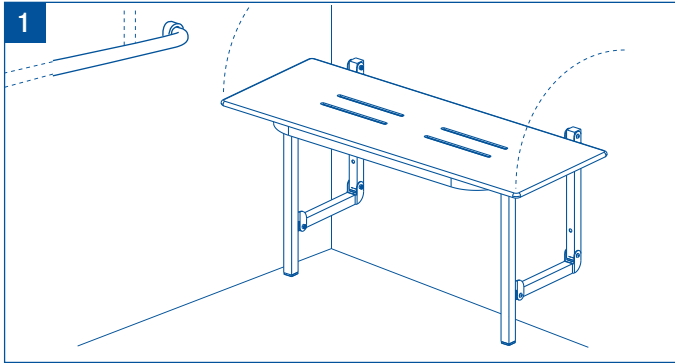

1
Accessible: Install as per AS 1428.1 Design for Access and Mobility. When in the horizontal position ensure seat does not present a hazard and the grab rail is accessible.

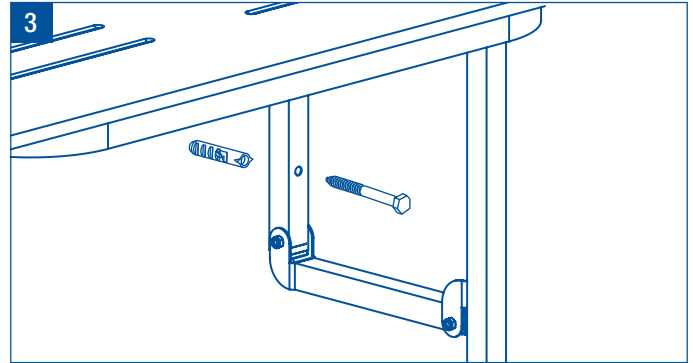

3
Fixing: Drill spot marks with 10mm bit. Plug and screw seat to wall using the 304 Stainless Steel M8 x 75mm hexagon coach screws supplied.

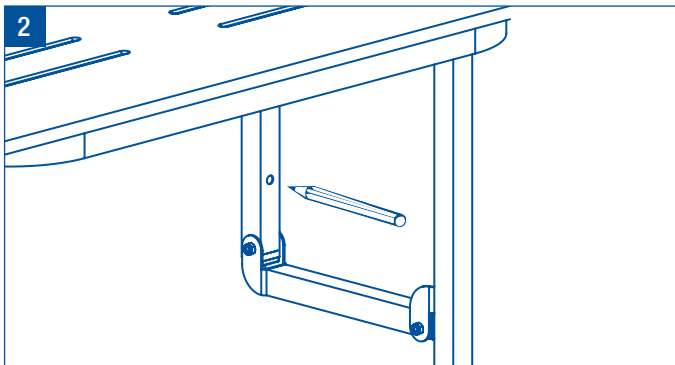

2
Positioning: In the horizontal position, level check and spot mark wall through seat frame mount holes.

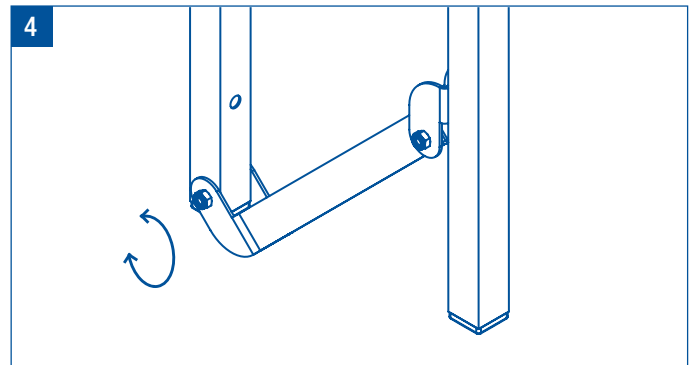

4
Checking: Check seat is firmly secured to wall and the Tension Grip Hinge screws are appropriate for ease of movement.

IMPORTANT: All measurements are subject to accepted manufacturing tolerances. To ensure accuracy please check actual product dimensions before drilling for installation. The manufacturer reserves the right to change specifications at any time without giving prior notification. This product should be installed by a qualified plumber. Local authority, Water Board, and Building Regulations may apply to the installation of this product, and you should consult the appropriate bodies on these requirements.

Our Promise

Con-Serv Corporation Australia Pty Ltd warrants all of its products (as below) with a Limited Lifetime Warranty on all mechanical parts from manufacturing defects in materials and workmanship under normal use in a domestic installation for as long as the original purchaser owns their home into which the particular product(s) was/were installed. A five year warranty (also on the terms below) will apply to commercial installations, irrespective of ownership. Con-Serv will repair or replace defective items correctly installed as per the Con-Serv installation instructions. Con-Serv will not be liable for defects arising through normal wear and tear. Item(s) must be returned with proof of purchase to Con-Serv at 17 Glentanna Street, Kedron, Queensland 4031. We will attend to your warranty claim after we make appropriate investigations. Contact our Service Manager during normal office hours on 1300 467 322 or at our email address of warranty@con-serv.com.au. If a warranty claim is accepted, Con-Serv will bear the reasonable costs of the return of the defective item(s) to us. A claim for expenses associated with making a claim for a defective product must be in writing and submitted to us with copies of supporting documents. The benefits given under our warranty are in addition to other rights and remedies of the customer under a law in relation to goods and services to which this warranty relates. Our goods come with guarantees that cannot be excluded under the Australian Consumer Law. You are entitled to a replacement or a refund for a major failure and compensation for any other reasonable foreseeable loss or damage. You are also entitled to have the goods repaired or replaced if the goods fail to be of acceptable quality and the failure does not amount to a major failure. Visit the Con-Serv website www.con-serv.com.au for the detailed warranty policy.

