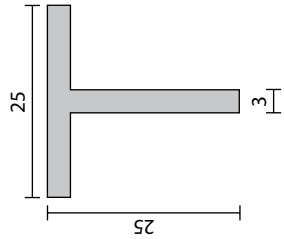

RP37
FITTING INSTRUCTIONS
 Astragal (Meeting Stile Seal)
**DETAILS****LOCATION**

Meeting stiles of doors.

STANDARD FINISH

Anodised Satin Clear (Silver) or PE Paint.

FIXING METHOD

Zinc plated, cross recess head CSK S.T. screws of the appropriate size and colour supplied.

DESCRIPTION

A simple heavy duty 'T' section to provide security for meeting stiles.

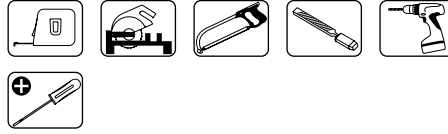
TOOLS

RAVEN PRODUCTS PTY. LTD.
 18-22 Aldershot Rd,
 Lonsdale SA 5160 Australia
 T +61 8 8384 5455
 raven.com.au

Designed and produced by
 Raven Products Pty Ltd
 (Australia)

Raven Products is an
 ISO9001 QMS company
 certified by SGS

Made in P.R.C. by Raven

Copyright: 07/24 (B)

Part No. ZSDSRP37

INSTALLATION**NOTES**

» RP37 may be fitted into a rebate on the meeting stile (**FIG.1**) or where large clearances are encountered, fixed to the meeting stile face (**FIG.2**) (user determined).

Check type and dimensions of latching hardware. The RP37 leg may be checked out around hardware to suit (user determined).

STEP 1 Determine which door RP37 is to be fitted to. If fixing to meeting stile face, go to **STEP 4. (FIG.2)** Otherwise **STEP 2.**

STEP 2 Remove door and machine 3mm x 22mm rebate to suit. (**FIG.1**)

STEP 3 Paint timber to prevent wood rotting. Rehang door.

STEP 4 Measure door length.

STEP 5 Machine cut RP37 to measurement.

STEP 6 Screw fix.

STEP 7 Open and close door to check for correct latching.

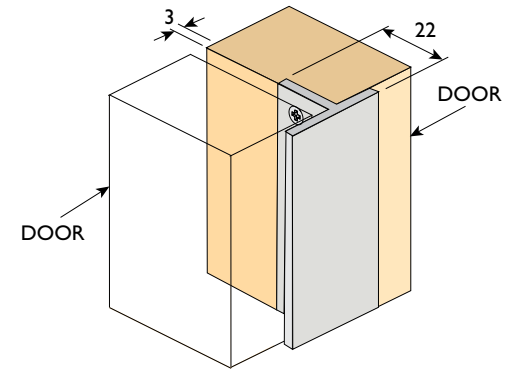
FIG.1**PAGE 1 OF 1****FIG.2**