

RP35Si



## FITTING INSTRUCTIONS

### Automatic Door Bottom Seal

### Anti-microbial Silicon Gasket

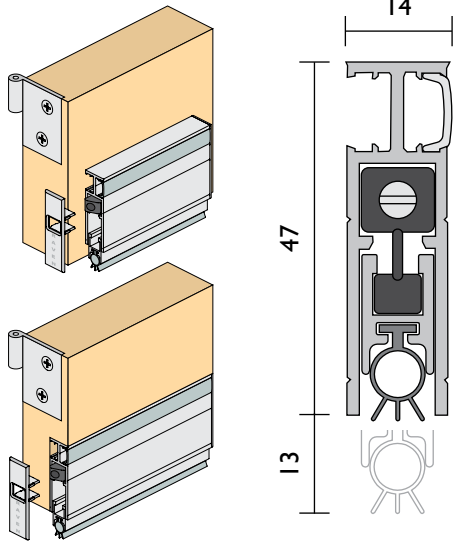

Category J door bottoms are intended for application to/with Classified hollow metal and steel covered composite type fire doors rated up to and including 3 hrs. and wood and plastic covered composite and wood core fire doors rated up to and including 1-1/2 hrs.

## DETAILS

### LOCATION

Solid core single and double butt hinged doors.

### MIN/MAX GAP

3mm to 13mm.

### SEAL MATERIAL

Silicon Rubber.

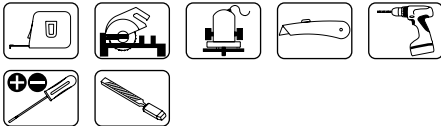

TOOLS

## REPLACEMENT SEAL

### RP308Si.

## DESCRIPTION

RP35Si is a heavy duty automatic door bottom seal which is spring loaded to lift clear of the sill as soon as the door leaf is opened. Acoustically designed for face mounted and semi-morticed applications. It is operated automatically by pressure against the door jamb on the adjustment block. Butt hinged doors only.

Complies with NCC S12C2 for fire & smoke doors. Tested to AS 1530.7, ISO 5925-1 & EN 1634-3.

## NOTES

- » If doors are exposed to weather, any untreated exposed timber should be sealed with a wood primer.
- » When cutting RP35Si to length, cut latch end only.
- » To suit hand of door simply turn the whole RP35Si around.

RAVEN PRODUCTS PTY. LTD.  
18-22 Aldershot Rd,  
Lonsdale SA 5160 Australia  
T +61 8 8384 5455  
raven.com.au

certifire  
CF-5710

### Registered Design

Raven Products is an  
ISO9001 QMS company  
certified by SGS

Designed and produced by  
Raven Products Pty Ltd  
(Australia)

Made by Raven in P.R.C.

Copyright: 07/24 (M)

Part No. ZSDSRP35Si

## WITHOUT ESCUTCHEON PLATES

Sealing performance is slightly improved if fitted without escutcheon plates for face mounted applications.

Nominal Seal Lengths:	Cuts back to:
1220mm	1070mm
1070mm	920mm
920mm	820mm
820mm	600mm
600mm	380mm
380mm	295mm

## WITH ESCUTCHEON PLATES

Total length of product is increased by 4mm.

Nominal Seal Lengths:	Cuts back to:
1224mm	1074mm
1074mm	924mm
924mm	824mm
824mm	604mm
604mm	384mm
384mm	299mm

## FACE MOUNT INSTALLATION

### NOTES

#### Aluminium Frame Only

- » On aluminium door frames it may be necessary to remove a small section of the door stop to give a flat surface for the adjustment block to strike against. This will need to be allowed for when cutting RP35Si to length.
- » When fitting the seal to the full width of the door the aluminium door stops can be checked out to suit seal profile.
- » Measure the distance between the door jambs in **STEP 1**.

**STEP 1** Remove the **cover strip** and the **latch** side escutcheon plate. **(FIG.3)** Turn whole RP35Si around so adjustment block is on hinge side to suit hand of door. **(FIG.1 & FIG.2)**

**STEP 2** Measure the distance between the door stops. **(FIG.1)** To allow for door opening clearance on the latch side **machine cut** RP35Si **shorter** by dimension "a". Cut latch end only.

### WITHOUT ESCUTCHEON PLATES

Seal Unit	FIG.1 DIM "a"
380, 600 & 820mm	2.5mm
920, 1070 & 1220mm	1mm

### WITH ESCUTCHEON PLATES

Seal Unit	FIG.1 DIM "a"
380, 600 & 820mm	4mm
920, 1070 & 1220mm	3mm

To allow for operating clearance, file the cut end of the **inner extrusion** 1mm shorter. Trim gasket. **(FIG.2)**

**STEP 3** Wind adjustment block all the way in. **(FIG.2)** Refer **STEP 7**.

**STEP 4** Position the RP35Si onto the door bottom hard against the **hinge** side stop. Fix in the **centre** of slots of the **outer extrusion** using screws supplied. **(FIG.2 & FIG.3)**

**STEP 5** For soft timber stops, position striker button where adjustment block meets door stop. **(FIG.4)**

**STEP 6** **Orientate** the **adjustment block** correctly. **(FIG.5)**

**STEP 7** Adjust seal travel to make full contact with sill. To adjust seal travel **either** pull out **adjustment block** to clear escutcheon plate. Firmly holding metal threaded rod, turn adjustment block **anti-clockwise** to increase seal travel and **clockwise** to reduce seal travel. **Or** turn adjustment screw with a flat blade screwdriver **(FIG.2)**. Turning screw **clockwise** increases seal travel, **anti-clockwise** reduces seal travel. **Note:** Only turn adjustment half a turn at a time then close door to check seal travel before further adjustment. To compress seal is not necessary since this will increase seal wear.

**STEP 8** The seal is factory set to seal a door bottom that is parallel with the floor (excludes 600mm unit length). To adjust, screw **level adjustment screw** with a Phillips head screwdriver. **(FIG.6)** **Note:** Adjustment is very sensitive. Screw clockwise to bias seal on **latch** side. Screw anti-clockwise to bias seal on **hinge** side.

**STEP 9** Trim cover strip to size and slide into end of outer extrusion to fit. Push in latch side escutcheon plate.

**FIG. 1**

#### PLAN VIEW

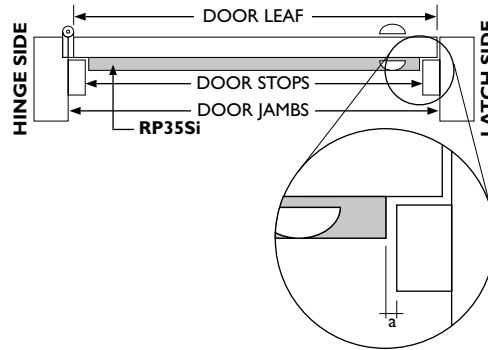

**FIG. 2**

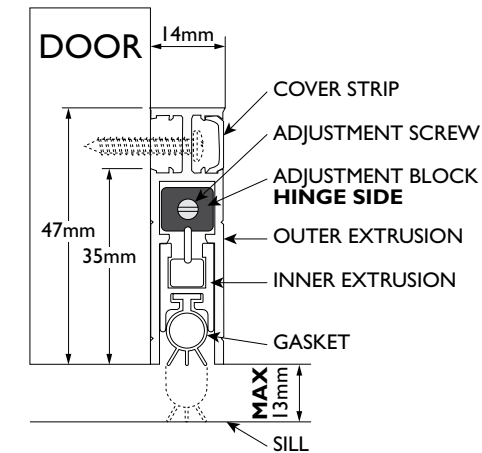

**FIG. 3**

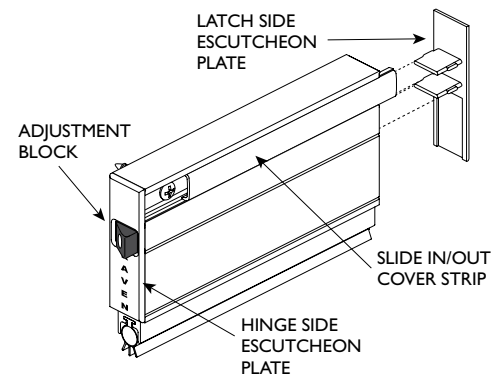

**FIG. 4**

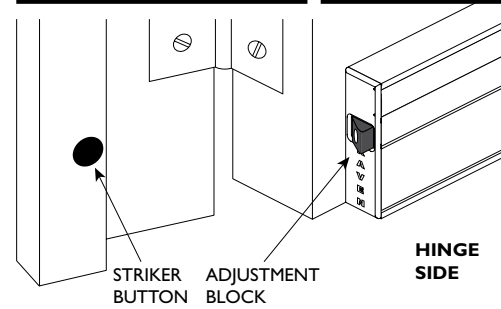

**FIG. 5**

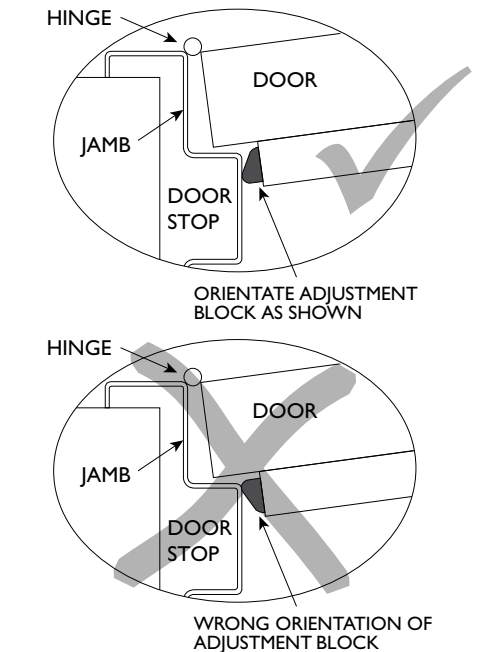

**FIG. 6**

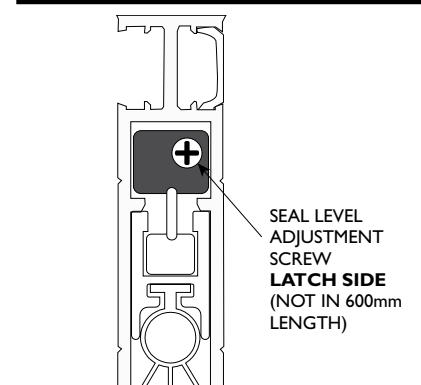

## SEMI-MORTICE INSTALLATION

- STEP 1** Remove the **cover strip** and the **latch side escutcheon plate**. **(FIG.3)** Turn whole RP35Si around so adjustment block is on hinge side to suit hand of door. **(FIG.1 & FIG.2)**
- STEP 2** Measure the width of the door leaf(s). **(FIG.1)** Machine cut RP35Si to this length less 2mm **shorter** to allow for latch side escutcheon plate. Cut latch end only.
- STEP 3** To allow for operating clearance, file the cut end of the **inner extrusion** 1mm shorter. Trim gasket. **(FIG.2)**
- STEP 4** Remove door. Machine rebate the bottom of the door leaf(s) **14mm x 47mm**. **(FIG.2 & FIG.7)** **Note:** If doors are exposed to weather, any untreated exposed timber should be sealed with a wood primer.
- STEP 5** Wind adjustment block all the way in. **(FIG.2)** Refer **STEP 9**.
- STEP 6** Position the RP35Si into the door bottom rebate aligned with the **hinge side**. Fix in the **centre** of slots of the **outer extrusion** using screws supplied. **(FIG.2 & FIG.3)**
- STEP 7** Re-hang door. For soft timber jambs, position striker button where adjustment block meets door jamb. **(FIG.4)**
- STEP 8** **Orientate** the **adjustment block** correctly. **(FIG.5)**
- STEP 9** Adjust seal travel to make full contact with sill. To adjust seal travel **either** pull out **adjustment block** to clear escutcheon plate. Firmly holding metal threaded rod, turn adjustment block **anti-clockwise** to increase seal travel and **clockwise** to reduce seal travel.

Or turn adjustment screw with a flat blade screwdriver **(FIG.2)**. Turning screw **clockwise** increases seal travel, **anti-clockwise** reduces seal travel. **Note:** Only turn adjustment half a turn at a time then close door to check seal travel before further adjustment. To compress seal is not necessary since this will increase seal wear.

- STEP 10** The seal is factory set to seal a door bottom that is parallel with the floor (excludes 600mm unit length). To adjust, screw **level adjustment screw** with a Phillips head screwdriver. **(FIG.6)** **Note:** Adjustment is very sensitive. Screw clockwise to bias seal on **latch side**. Screw anti-clockwise to bias seal on **hinge side**.
- STEP 11** Trim cover strip to size and slide into end of outer extrusion to fit. Push in latch side escutcheon plate.

**FIG. 1**

### PLAN VIEW

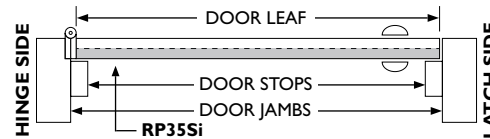

**FIG. 2**

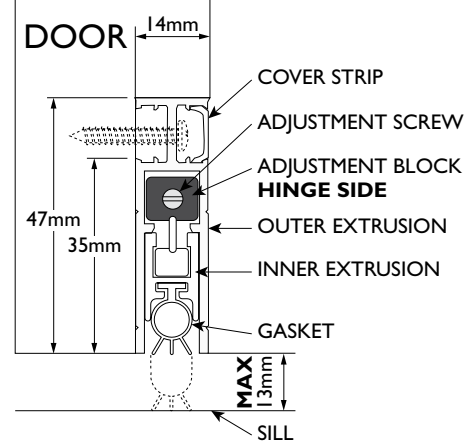

**FIG. 3**

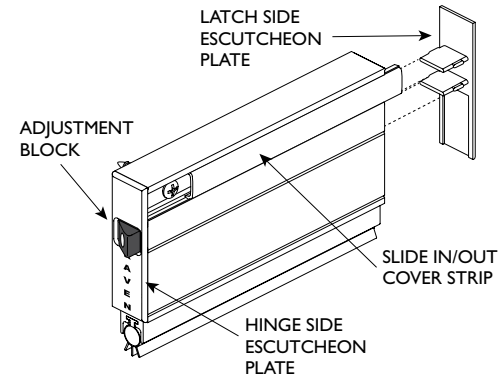

**FIG. 4**

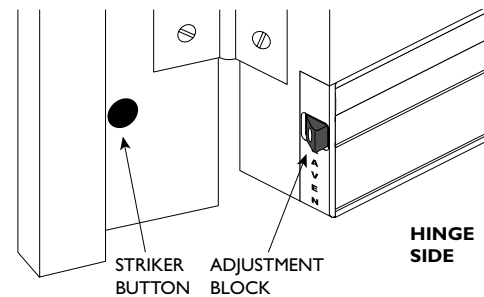

**FIG. 5**

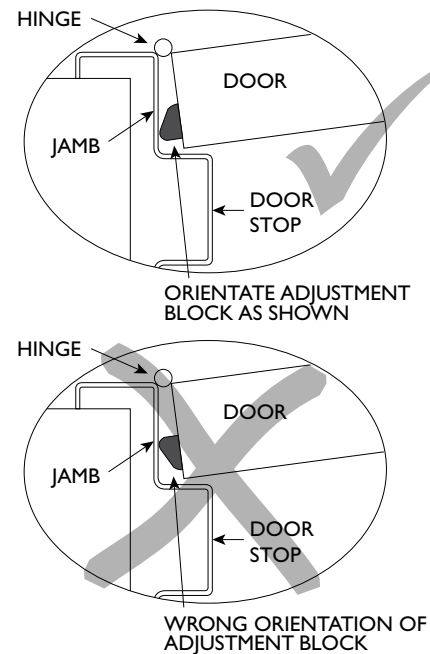

**FIG. 6**

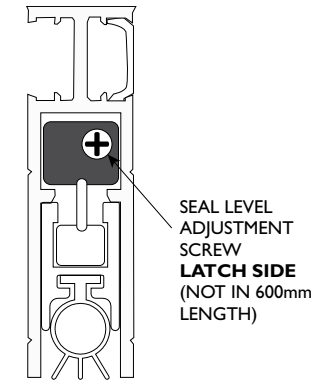

**FIG. 7**

Double doors (rebated meeting stiles)  
Minimum 40mm thickness door recommended.  
**Note:** Concealed flush bolt (by others).

