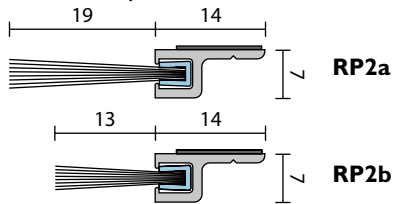

RP2a RP2b**FITTING INSTRUCTIONS****Nylon Brush Strip Seal****DETAILS****LOCATION**

Door bottoms of single, double or sliding doors.
(Double acting doors - RP2a only).

MIN/MAX GAP

RP2a - Up to 19mm (user determined).

RP2b - Up to 13mm (user determined).

SEAL MATERIAL

Fine dense, black nylon filaments, UV stabilised.

FIXING METHOD

Self-adhesive backing. Can screw fix.

Note: Contact surface must be clean, smooth and if painted, well cured. Self-adhesive seals will not adhere to oiled or alkyd finishes or to easy clean wash and wear paint surfaces.

DESCRIPTION

RP2a & RP2b are nylon brush strip seals with aluminium holders that mount to the inside or outside of doors. They are ideal for sliding or double acting doors.

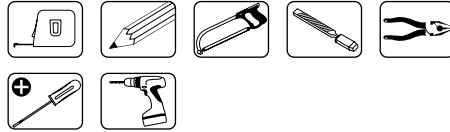
TOOLS

RAVEN PRODUCTS PTY. LTD.
18-22 Aldershot Rd,
Lonsdale SA 5160 Australia
T +61 8 8384 5455
raven.com.au

Raven Products is an
ISO9001 QMS company
certified by SGS

Designed and produced by
Raven Products Pty Ltd
(Australia)

Made in P.R.C. by Raven
Part No. ZSDSRP2a 2b

Copyright: 07/25 (F)

DISCLAIMER

Raven self-adhesive products are used successfully in many door and window sealing applications. Raven literature and product specifications contain numerous examples of self-adhesive products that help to solve door and window sealing problems. However, experience has shown that even for one and the same objective, the exact requirements may vary due to various site and environmental conditions that are outside our control. It is understood that users will independently determine the suitability of these products including the surfaces to which the self-adhesive product is to be installed. Raven recommends all users carry out their own site test or evaluation for each case, to confirm that the product selected is appropriate for the specific application. The Raven Technical support team will be happy to assist. All Self-adhesive product, technical data and recommendations although based upon our research and believed to be reliable are given in good faith but without warranty.

INSTALLATION

Preparation Tip: Raven suggest using methylated spirits and a lint free cloth to wipe down smooth and well cured surfaces so they are perfectly clean. **Note:** Self-adhesive seals will not adhere to oil stained or “easy clean” painted surfaces that contain silicon, Teflon or other non-stick additives.

STEP 1 Slide out brush strip from aluminium holder. **(FIG.1)**

STEP 2 With fine tooth hacksaw, cut aluminium holder only, to desired length. Remove burrs. **(FIG.1)**

STEP 3 With combination pliers, cut brush strip to suit. **(FIG.2)** (This locks in bristles).

STEP 4 To stop brush strip sliding out, bow brush strip slightly and slide back into aluminium holder. **(FIG.3)**

STEP 5 If using self-adhesive fixing method, make sure surface to be adhered to is smooth, clean and if painted, well cured. Methylated spirit or alcohol is ideal for cleaning. Do not use an oil based solvent. If screw fixing, proceed to **STEP 7**.

STEP 6 Before removing backing from adhesive strip, position seal and pencil mark fixing location. Nylon bristles should lightly engage sealing surface.

STEP 7 For screw fixing method, mark and drill holes along vee groove **(FIG.1)**

STEP 8 Remove backing from adhesive and **lightly** position on pre-marked fixing location **STEP 6**. Press firmly into place along full length. **Note:** Adhesive tape is very aggressive. Maximum bond is achieved in 24 hours @>20°C. Use a sharp blade or pin to carefully separate backing from adhesive **(FIG.4)**.

STEP 9 Screw fix in position.

FIG.1

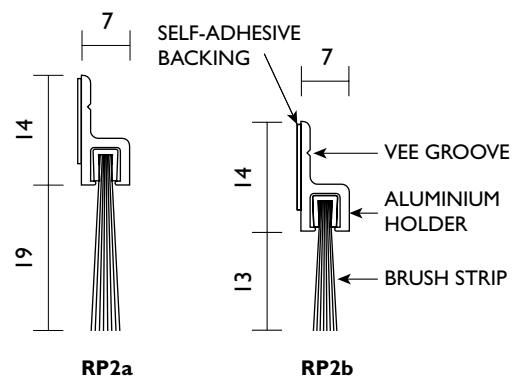

FIG.2

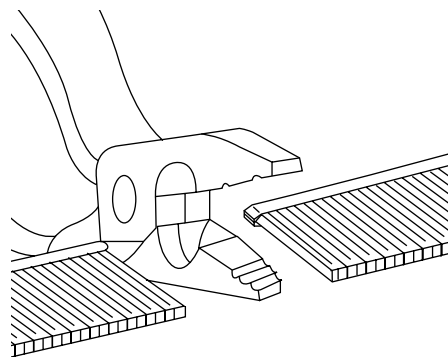

FIG.3

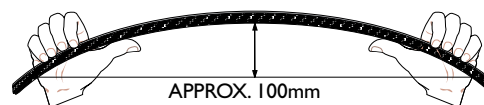

FIG.4

