

RP26

FITTING INSTRUCTIONS

Door Bottom Seal

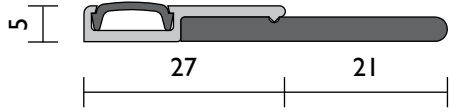

DETAILS

LOCATION

Door bottoms, single or double outward opening, butt hinged or tilt-up doors. Can be used as an astragal seal.

MIN/MAX GAP

5mm to 20mm (user determined).

SEAL MATERIAL

EPDM.

FIXING METHOD

Zinc plated, cross recess head S.T. screws of the appropriate size are supplied.

ADDITIONAL DETAILS

SEAL SIZES

Available in stock lengths.

USED IN CONJUNCTION

Raven threshold plates.

REPLACEMENT SEAL

RP326.

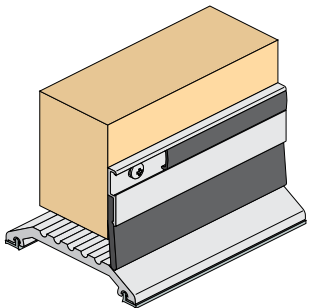

DESCRIPTION

A heavy duty EPDM sweep seal for door bottoms of outward opening doors. It has slotted holes for the adjustment of its concealed fixings, behind a push-in cover strip.

TOOLS



RAVEN PRODUCTS PTY. LTD.
18-22 Aldershot Rd,
Lonsdale SA 5160 Australia
T +61 8 8384 5455
raven.com.au

Designed and produced by
Raven Products Pty Ltd
(Australia)

Raven Products is an
ISO9001 QMS company
certified by SGS

Made in P.R.C. by Raven

Copyright: 07/24 (C)

Part No. ZSDSRP26

INSTALLATION

NOTES

- » The RP26 may be fitted on the front or back of the door. For inward opening doors check that the floor level is even otherwise seal may jam.

STEP 1 Remove cover strips. **(FIG.1)**

STEP 2 With door closed, measure the door width.

STEP 3 Machine cut RP26 to measurement. **(FIG.1)**

STEP 4 Position RP26 against the door and drill pilot holes in centre of slots to suit.

STEP 5 Screw fix lightly in centre of slots with pan head screws supplied.

STEP 6 With door closed, adjust RP26 so that rubber fin lightly engages sill or leading edge of threshold plate. **(FIG.2)**

STEP 7 Open and close door and check sealing action. Tighten all fixing screws.

STEP 8 Trim screw cover strips 3mm less than RP26 and fit in screw channel. **(FIG.1)** Centre cover strips to allow cover strip lock tabs each end. Push in cover strip lock tabs and lightly tap in flush with a small hammer. The cover strip lock tabs lock the cover strips in position. **(FIG.2)**

FIG.1

PAGE 1 OF 1

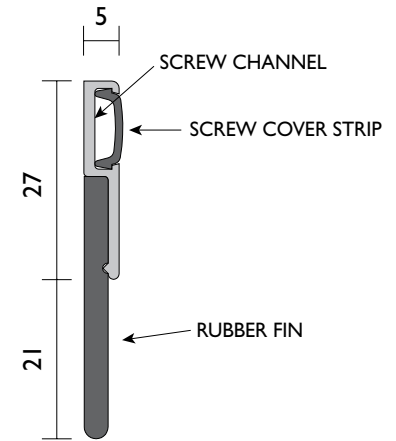

FIG.2

