

RP18



A heavy duty threshold plate designed for butt hinged, single, double, or pivot hinge doors. It allows the door leaf to clear high pile carpets which have been laid up to the frame. It has been designed to accommodate concealed screw fixings through the door jambs.

An aluminium door frame, complete with the threshold plate, can be assembled by a door fabricator prior to transporting as a complete unit. RP18 will accommodate Pivot Sets for most types of Transom Closers.

Used in Conjunction with Raven door bottom seals RP2b and RP74 (RP8Si butt hinged doors).

Location: Door sill of single, double butt hinged or pivot hinged doors.

Finish: Satin clear (silver) anodised aluminium (25µm).

Fixing: By door fabricator.

Sizes: Available in stock lengths.

Approvals

Cert. GVV1.R37913

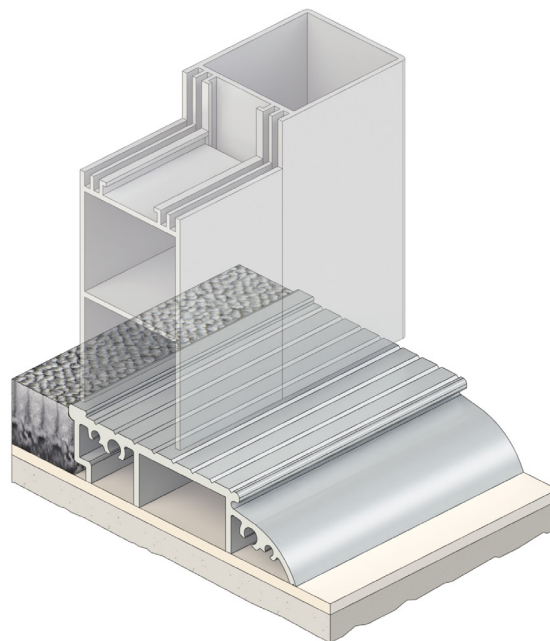
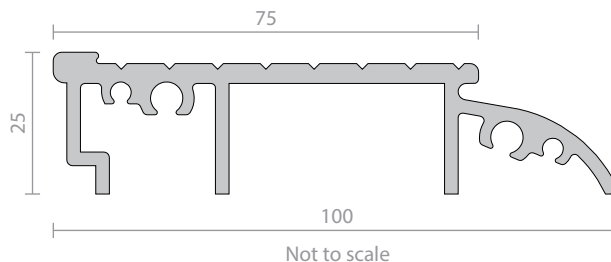

RP19



A heavy duty threshold plate with ribbed profile and integral sill gaskets.

Can be used in conjunction with Raven door bottom seals to prevent rain, draughts, noise and smoke infiltration.

RP19 has been designed to accommodate a concealed screw fix through the door jambs.

Location: Door sill.

Finish: Satin clear (silver) anodised aluminium (25µm).

Fixing: Screw fix. Colour matched zinc plated, cross recess head CSK S.T. screws supplied.

Seal: RP404a. Grey flexible PVC.

Sizes: Available in stock lengths.

Approvals

Access & Mobility NZ: NZ BC Compliance Doc. D1/AS1 1.3.2.

UK/EU: Approved Document M.

Fire AUS/NZ: NCC Spec. C3.4. AS1530.4 & AS/NZS 1905.1. NZ BC Compliance Doc. C/AS1 6.19.2(a) & App. C6.1.1.

UK/EU: Approved Document B. BS 476 Pt. 20 & 22 (similar to BS EN 1634-1).

FRL & FRR-/240/30.

BAL ≤FZ when used with a BAL rated door bottom seal in accordance with AS 3959.

