

RP15

FITTING INSTRUCTIONS

Nylon Brush Strip Seal

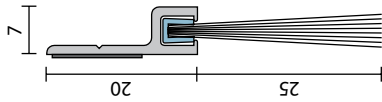

DETAILS

LOCATION

Bottom of single, double or sliding doors.

MIN/MAX GAP

Up to 25mm (user determined).

FIXING METHOD

Self-adhesive backing. Can screw fix.

Note: Contact surface must be clean, smooth and if painted, well cured. Self-adhesive seals will not adhere to oiled or alkyd finishes or to easy clean wash and wear paint surfaces.

USED IN CONJUNCTION

Raven RP13, RP82 (optional).

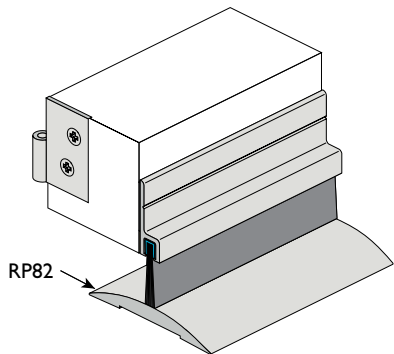

DESCRIPTION

RP15 is a nylon brush strip seal with aluminium carrier that is ideal where larger gaps are encountered.

TOOLS

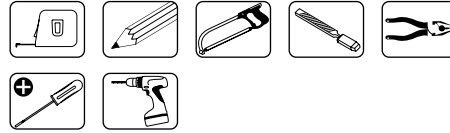

RAVEN PRODUCTS PTY. LTD.
18-22 Aldershot Rd,
Lonsdale SA 5160 Australia
T +61 8 8384 5455
raven.com.au

Designed and produced by
Raven Products Pty Ltd
(Australia)

Raven Products is an
ISO9001 QMS company
certified by SGS

Made in P.R.C. by Raven

Copyright: 06/24 (D)

Part No. ZSDSRP15

DISCLAIMER

Raven self-adhesive products are used successfully in many door and window sealing applications. Raven literature and product specifications contain numerous examples of self-adhesive products that help to solve door and window sealing problems. However, experience has shown that even for one and the same objective, the exact requirements may vary due to various site and environmental conditions that are outside our control. It is understood that users will independently determine the suitability of these products including the surfaces to which the self-adhesive product is to be installed. Raven recommends all users carry out their own site test or evaluation for each case, to confirm that the product selected is appropriate for the specific application. The Raven Technical support team will be happy to assist. All Self-adhesive product, technical data and recommendations although based upon our research and believed to be reliable are given in good faith but without warranty.

INSTALLATION

Preparation Tip: Raven suggest using methylated spirits and a lint free cloth to wipe down smooth and well cured surfaces so they are perfectly clean. **Note:** Self-adhesive seals will not adhere to oil stained or “easy clean” painted surfaces that contain silicon, Teflon or other non-stick additives.

STEP 1 Slide out brush strip from aluminium holder. **(FIG.1)**

STEP 2 With fine tooth hacksaw, cut aluminium holder only, to desired length. Remove burrs. **(FIG.1)**

STEP 3 With combination pliers, cut brush strip to suit. **(FIG.2)** (This locks in bristles).

STEP 4 To stop brush strip sliding out, bow brush strip slightly and slide back into aluminium holder. **(FIG.3)**

STEP 5 If using self-adhesive fixing method, make sure surface to be adhered to is smooth, clean and if painted, well cured. Methylated Spirits or alcohol is ideal for cleaning. Do not use an oil based solvent. If screw fixing, proceed to **STEP 7**.

STEP 6 Before removing backing from adhesive strip, position seal and pencil mark fixing location. Nylon bristles should lightly engage sealing surface.

STEP 7 For screw fixing method, mark and drill holes along vee groove **(FIG.1)** Screws not supplied.

STEP 8 Remove backing from adhesive and **lightly** position on pre-marked fixing location **STEP 6**. Press firmly into place along full length. **Note:** Adhesive tape is very aggressive. Maximum bond is achieved in 24 hours @>20°C. Use a sharp blade or pin to carefully separate backing from adhesive **(FIG.4)**.

STEP 9 Screw fix in position.

FIG.1

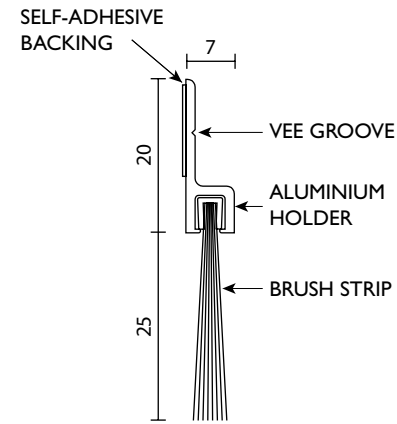

FIG.2

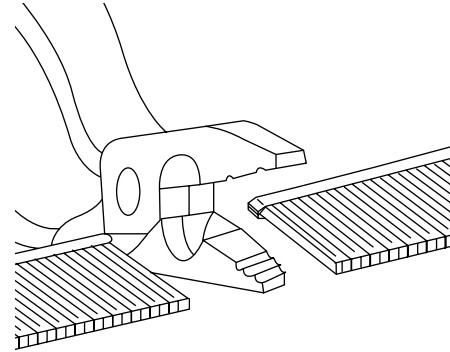

FIG.3

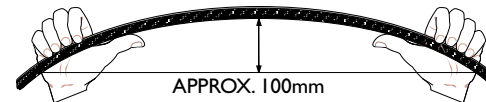

FIG.4

