

RPI20 / RPI50

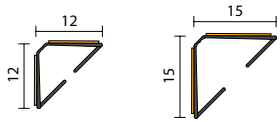

FITTING INSTRUCTIONS

Self-adhesive Door and Window Frame Seal



Category J gaskets for use with Listed steel frames and/or Classified steel covered composite, hollow metal doors rated up to 3 hrs; wood and plastic covered composite doors rated up to 1-1/2 hrs; and wood core doors rated for 20 minutes.

R37913

DETAILS

LOCATION

Around rebated frames of single or double butt hinged doors and windows.

MIN/MAX GAP

3mm to 5.5mm.

SEAL MATERIAL

Rigid and flexible flame retardant PVC, with an aggressive self-adhesive backing tape.

FIXING METHOD

Self-adhesive.

Note: Contact surface must be clean, smooth and if painted, well cured. Self-adhesive seals will not adhere to oiled or alkyd finishes or to easy clean wash and wear paint surfaces.

DISCLAIMER

Raven self-adhesive products are used successfully in many door and window sealing applications. Raven literature and product specifications contain numerous examples of self-adhesive products that help to solve door and window sealing problems. However, experience has shown that even for one and the same objective, the exact requirements may vary due to various site and environmental conditions that are outside our control. It is understood that users will independently determine the suitability of these products including the surfaces to which the self-adhesive product is to be installed. Raven recommends all users carry out their own site test or evaluation for each case, to confirm that the product selected is appropriate for the specific application. The Raven Technical support team will be happy to assist. All Self-adhesive product, technical data and recommendations although based upon our research and believed to be reliable are given in good faith but without warranty.

DESCRIPTION

Delta Seal™

RPI20 is a co-extruded PVC, acoustic and smoke seal. Discreetly located in the protected corners of rebated timber or steel door frames. RPI20 is suitable for new and retrofit applications.

TOOLS



certifire
CF 5710

RAVEN PRODUCTS PTY.LTD.
18-22 Aldershot Rd,
Lonsdale SA 5160 Australia
T +61 8 8384 5455
www.raven.com.au

Designed and produced by
Raven Products Pty Ltd
(Australia)
Made in P.R.C. by Raven

Raven Products is an
ISO9001 QMS company
certified by SGS

Copyright: 08/24 (H)
Part No. ZSDSRPI20 150

NOTES

- » During the installation process be careful to avoid removing and repositioning the seal as this may lessen the adhesive bond.
- » Before touch up paint is used, check that the seal is correctly positioned (**FIG.1**) **PAGE 2** and the door or window opens and latches properly.
- » The door or window must be kept open until all paint is well cured. Soft or uncured paint will bind the door or window to the seal.

INSTALLATION

Preparation Tip: Raven suggest using methylated spirits and a lint free cloth to wipe down smooth and well cured surfaces so they are perfectly clean. **Note:** Self-adhesive seals will not adhere to oil stained or “easy clean” painted surfaces that contain silicon, Teflon or other non-stick additives.

STEP 1 Close the door or window. Check the clearance around the perimeter. The gap should not be less than 3mm. If required, plane or sand the door or window stile edges so that the seal, when fitted, allows for easy closing and latching. Refer **NOTES**.

STEP 2 Ensure that the surface which the seal is to be adhered to is clean, smooth and if painted, well cured. Refer **DISCLAIMER**.

STEP 3 Measure the door or window jamb perimeter to determine seal lengths required. **(FIG.2)**

STEP 4 The **stop** side of RPI20 should be mitred at corners and the **jamb** side should be butt jointed. **(FIG.1)** Trim the seal to length with a pair of scissors or knife.

STEP 5 Install the vertical jamb seals first. Peel off about 150mm of the self-adhesive backing from one of the seals to expose adhesive. **Note:** Use a sharp blade or pin to carefully separate backing from adhesive **(FIG.3)**.

STEP 6 Starting at the top corner of the jamb **(FIG.2)** progressively remove backing and run a blunt tool or finger down the centre of the seal. Ensure to fix the seal evenly and firmly into place.

STEP 7 Check door or window for correct closing and latching.

FIG.1

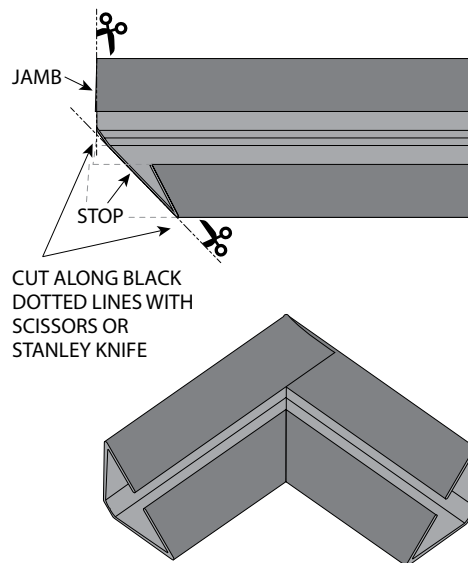

FIG.2

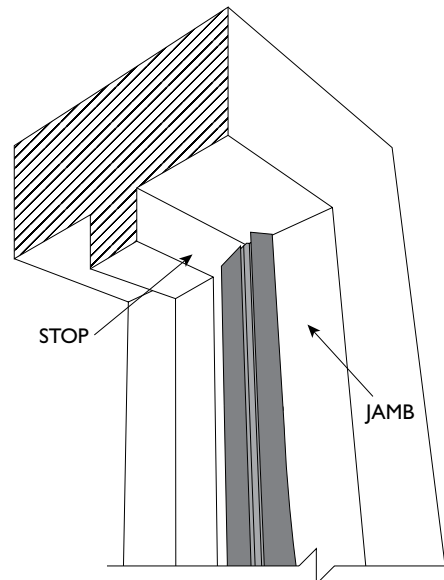

FIG.3

