

ADDITIONAL DETAILS**SEAL MATERIAL**

Silicon Rubber.

REPLACEMENT SEAL

RP3126Si.

DESCRIPTION

A concealed, automatic door bottom seal to suit medium temperature smoke and energy door seal applications.

RP144Si features twin silicon bulb gaskets and is spring loaded to lift clear of the floor as soon as the door leaf is opened by a few millimetres.

Mounted into the bottom hollow rail of metal doors, the seal is operated automatically by pressure against the door jamb on its adjustable strike block.

NOTES

- » Do not cut RP144Si shorter than the length recommended as this may affect the seal operation and void warranty.
- » If doors are exposed to weather, any exposed metal should be sealed with a suitable paint.
- » For double doors, plain meeting stiles are required.
- » Do not use power or battery driven tools to fit escutcheon screws.

RAVEN PRODUCTS PTY. LTD.
18-22 Aldershot Rd,
Lonsdale SA 5160 Australia
T +61 8 8384 5455
raven.com.au

Raven Products is an
ISO9001 QMS company
certified by SGS

Designed and produced by
Raven Products Pty Ltd
(Australia)

Made in P.R.C. by Raven

Copyright: 09/24 (I)

Part No. ZSDSRP144Si

MINIMUM CUT BACK LENGTHS

Nominal Seal Lengths: Cuts back to:

1350mm	1220mm
1220mm	920mm
920mm	600mm

RP144Si

FITTING INSTRUCTIONS

Automatic Door Bottom Seal

Anti-microbial Silicon Gaskets

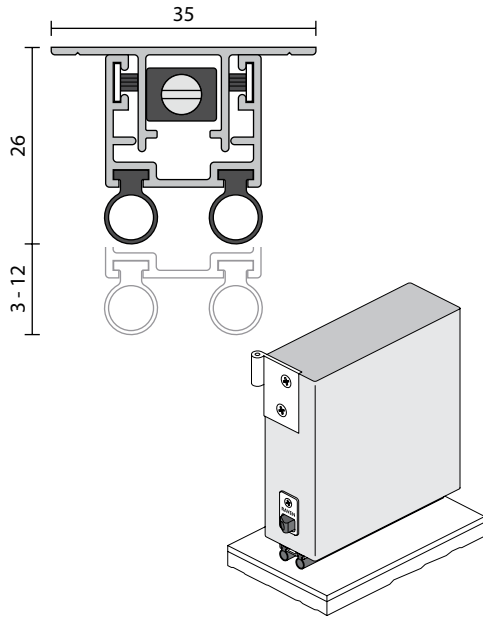

Category J, intended for application to/with Classified hollow metal and steel covered composite type fire doors rated up to and including 3 hrs; wood and plastic covered composite and wood core fire doors rated up to and including 1-1/2 hrs; wood core doors rated for 20 minutes.

DETAILS**LOCATION**

Concealed in the bottom of single and double metal framed and clad butt hinged doors.

MIN/MAX GAP

3mm to 12mm.

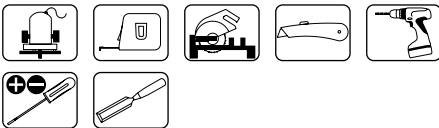
TOOLS

CONCEALED INSTALLATION WITHIN HOLLOW BOTTOM RAIL OF BUTT HINGED METAL DOORS, BOTH SINGLE AND DOUBLE.

- FOR METAL DOOR FABRICATORS

STEP 1 Remove door. For metal clad doors go to **STEP 2**. On aluminium door bottom rails, cut out metal of internal stiles, so that the seal mounts in centre of rail. Machine inside of stile to suit.

STEP 2 Drill 13.0mm dia. hole in **hinge** side stile for escutcheon plate. **(FIG.1)**

STEP 3 Machine cut RPI44Si to exact length between inside faces of stiles. Cut latch end only. Cut gaskets and fins with a sharp wet knife. **(FIG.2)**

STEP 4 Push escutcheon plate into 13.0mm drilled hole. Drill pilot hole for escutcheon plate screw. Screw fix escutcheon plate with countersunk (CSK) screw supplied. **(FIG.3)** **Note:** Do not use a powered driver.

STEP 5 Drill along vee grooves to suit fixing screws supplied **(FIG.2)**.

STEP 6 Wind adjustment block all the way in. **(FIG.2)** Refer **STEP 10**.

STEP 7 Insert **adjustment block** end of RPI44Si into hinge side of bottom rail so adjustment block protrudes through escutcheon plate. Push other end of seal into latch side of bottom rail. **(FIG.4)**

STEP 8 Screw fix with self drilling screws supplied. **(FIG.4)**

STEP 9 Hang door.

STEP 10 Orientate the **adjustment block** correctly. **(FIG.5)**

STEP 11 Adjust seal travel to make full contact with sill. To adjust seal travel **either** pull out **adjustment block** to clear escutcheon plate. Firmly holding metal threaded rod, turn adjustment block **anti-clockwise** to increase seal travel and **clockwise** to reduce seal travel. **Or** turn adjustment screw with a flat blade screwdriver **(FIG.2)**. Turning screw **clockwise** increases seal travel, **anti-clockwise** reduces seal travel. **Note:** Only turn adjustment half a turn at a time then close door to check seal travel before further adjustment. To compress seal is not necessary since this will increase seal wear.

FIG.1

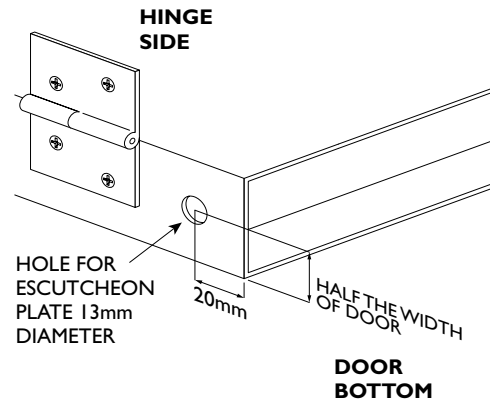

FIG.2

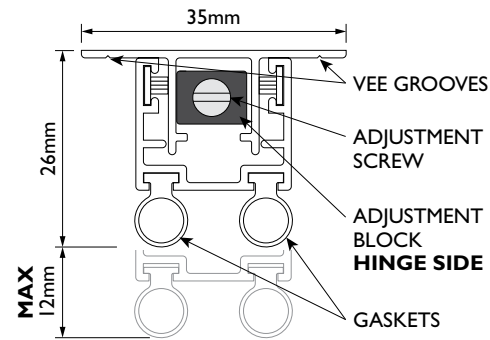

FIG.3

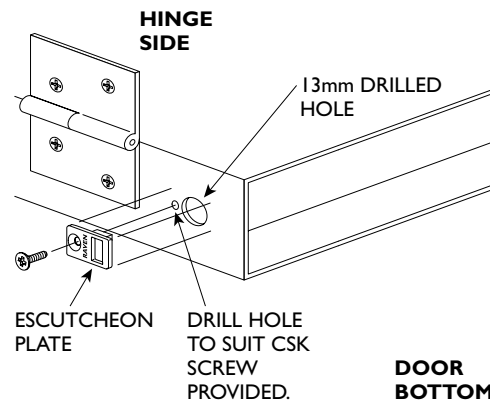

FIG.4

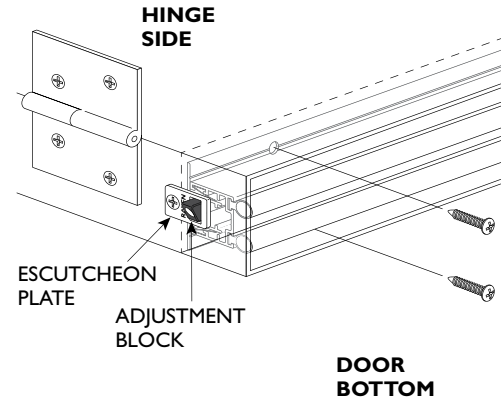

FIG.5

