

DESCRIPTION

Threshold Plates are hard anodised, aluminium extrusions that are fitted to the sill under doors; they provide a clean delineation between adjacent floor surfaces. A weather barrier in themselves, threshold plates provide an optimum sealing surface for door bottom seals. Being hard wearing, threshold plates offer an elevated sealing surface which, in the case of door bottom sweep seals, prevents contact or excessive resistance over carpeted, uneven or sloping floors.

Raven Threshold Plates have been designed to withstand the day to day rigours of heavy pedestrian and wheeled traffic encountered in commercial buildings. Their low profiles do not impede wheeled traffic nor do they present any tripping hazard to pedestrian traffic.

RP116 is a heavy duty threshold plate designed for butt hinged, single, double, or pivot hinge doors. A low profile threshold plate used in conjunction with Raven door bottom seals to prevent rain, draught and smoke infiltration.

RAVEN PRODUCTS PTY. LTD.
18-22 Aldershot Rd,
Lonsdale SA 5160 Australia
T +61 8 8384 5455
raven.com.au

Raven Products is an
ISO9001 QMS company
certified by SGS

Designed and produced by
Raven Products Pty Ltd
(Australia)

Made in P.R.C. by Raven
Copyright: 03/25 (E)
Part No. ZSDSRP116

INSTALLATION

NOTES

- » If installing a door bottom seal refer to door bottom seal instructions for correct fitting location of the RP116. It may be necessary to check out the RP116 ends to allow for the door stops. Where the RP116 meets the door jamb, sealant may be applied (user determined).
- » Can be fixed with high strength, multipurpose polyurethane adhesive such as Sikaflex IIFC or equivalent.

- STEP 1** Machine cut RP116 to full width between jambs and/or door stops. **(FIG.1)**
- STEP 2** Drill and countersink RP116 to suit screws provided or apply adhesive to RP116 bottom, refer notes. **(FIG.2)**
- STEP 3** Position RP116 on door sill to suit application. **(FIG.3)**
- STEP 4** Screw fix firmly but do not over tighten. Alternatively adhesive fix.

Note: If screw fixing in exposed external coastal areas, substitute the supplied fixing screws with equivalent stainless steel screws.

FIG.2

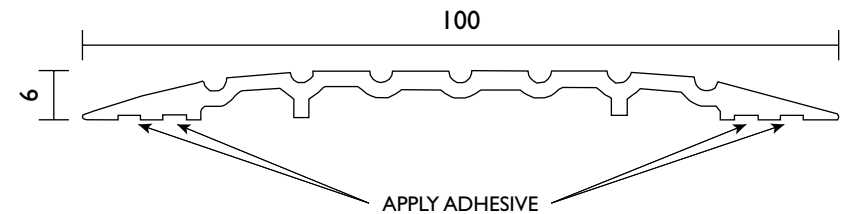
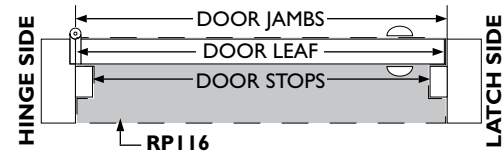

FIG.1

PLAN VIEW

BUTT HINGE DOOR



PIVOT DOOR

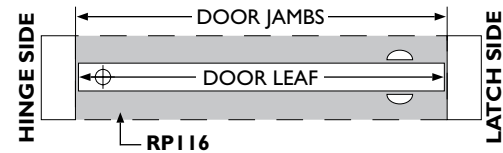

FIG.3

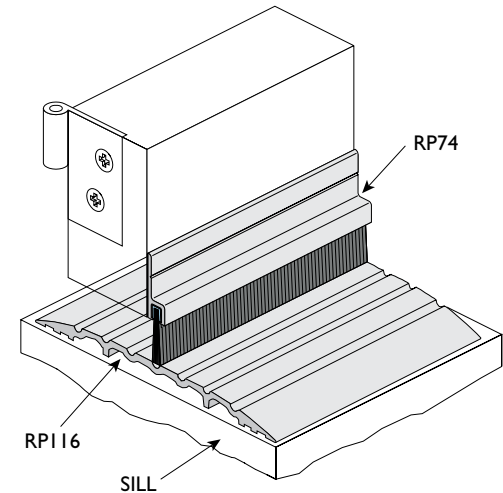

FIG.2

RP116



FITTING INSTRUCTIONS

Threshold Plate

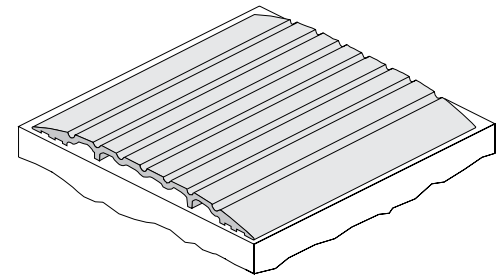
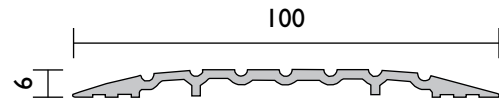

DETAILS

LOCATION

Door sill.

FIXING METHOD

Zinc plated, cross recess head CSK S.T. screws of the appropriate size and colour are supplied, or it can be fastened with adhesive (by others).

USED IN CONJUNCTION

Raven door bottom seals.

TOOLS

