

ML_950DA_WHT Automatic Soap Dispenser

Material Specifications

- ABS Plastic Body

Mounting

- Surface Mount Concealed Fix

Dimensions

- 112mmW x 265mmH x 104mmD

Installation Guidelines

- *May be subject to Australian Building Code Regulations for height and location fixing and may be subject to placement as per architectural drawings. In all cases, this is the responsibility of the installer.*
- **Recommended Installation height for above counter top: Distance (minimum typical) is 200mm above counter top to ensure auto sensor detection works effectively.**



For Dry Wall or Tile

1. Tape the installation template to the appropriate location on the mounting surface.
2. Drill two holes at marked locations 6.4mm diameter (1/4"Ø).
3. Insert two plastic anchors (supplied) into the drilled holes and remove template.
4. Insert the two screws (supplied) into top plastic anchors and leave 1/8" space from the wall under head for hanging dispenser.
5. Hang the dispenser on the 2 screws through the keyhole slots on the top of the backplate.
6. Use the key (supplied) to unlock the dispenser and pull out the housing cover.
7. Tighten all screws and ensure unit is level. Insert the soap reservoir and close the unit to finish installation.

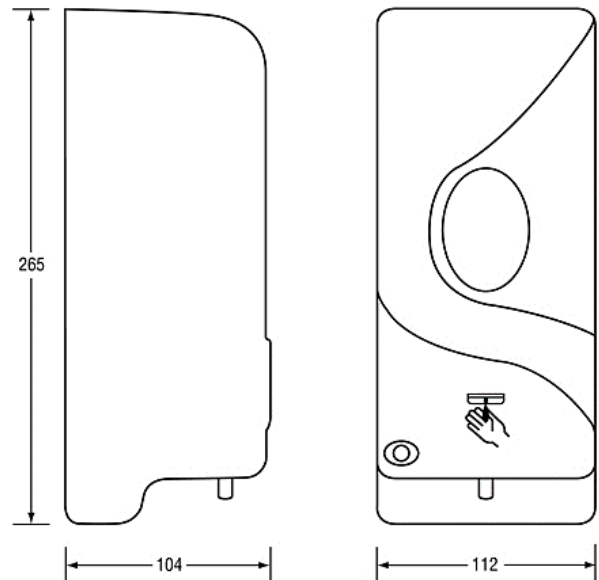

For Mirror

1. Clean mounting surface with isopropyl alcohol.
2. Mark outline of dispenser on the mirror with masking tape.
3. Attach self-adhesive pads (supplied) to dispenser backplate.
4. Remove the other paper liner from pads and place unit on mounting surface with even steady pressure and hold for 1 minute.

The photographs and line drawings of the products presented above are representational only. Metlam Australia Pty Ltd reserves the right to, and from time to time, make changes and improvements in design and dimensions.

5. Let tape cure for 10 hours prior to filling dispenser with soap for use.

Features

- Provides one drop per cycle (1~1.5mL)
- Infrared Sensor Operated/Powered by three C Batteries (not included)
- Provides approx. 100,000 drops/one-year usage
- Solid Blue Light for Dispensing and Flashing Blue Light for Low Battery
- Can be used with select Medical Grade Soaps
- Liquid Level Indicator
- Lockable (key provided)
- 950mL Removable Reservoir



This product is AS1428.1 compliant (accessible compliant) when installed in accordance with the guidelines.

The technical recommendations contained in this document are necessarily of a general nature and should not be relied on for specific applications without first securing competent advice. Whilst Metlam Australia Pty Ltd has taken all reasonable steps to ensure the information contained herein is accurate and current, it does not warrant the accuracy or completeness of the information and does not accept liability for errors or omissions. Any Commercial product should only be installed by a competent tradesperson and serviced/maintained by knowledgeable janitorial staff or competent people. Metlam Australia accepts no responsibility for any damage to product, walls or fixtures due to incorrect installation or maintenance of any of their products.

The photographs and line drawings of the products presented above are representational only.
Metlam Australia Pty Ltd reserves the right to, and from time to time, make changes and improvements in design and dimensions.