

ML8100V Vertical Baby Change Station

Material Specifications

- Hi-density bacteria resistant Polyethylene body
- Stainless Steel hinge

Dimensions

- **Open:** 885mmH x 480mmW x 885mmD
- **Closed:** 870mmH x 480mmW x 126mmD

Installation Guidelines

AS1428.1 Standard - Baby Change Table Mounting Instructions

- *Baby Change Tables shall not encroach into the circulation space of any other toilet facility when in the folded position*
- *Baby Change Tables shall have a maximum height of 820mm and a minimum clearance of 720mm when in the open position (above finished floor level).*

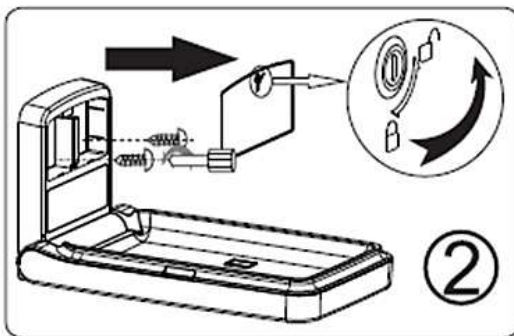
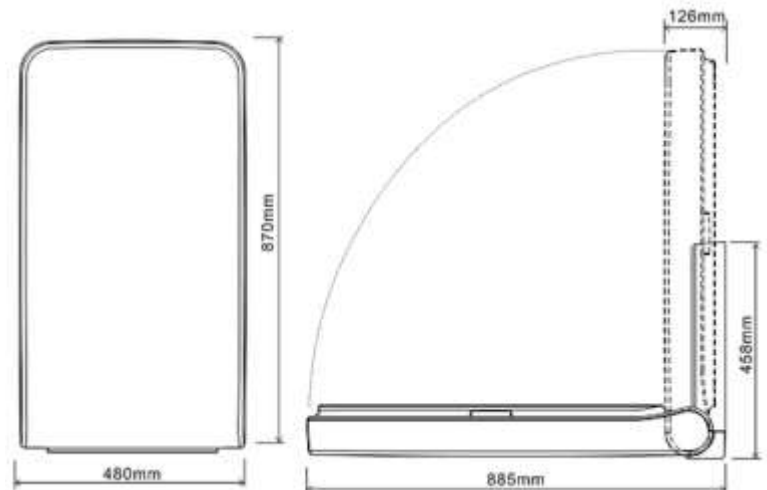
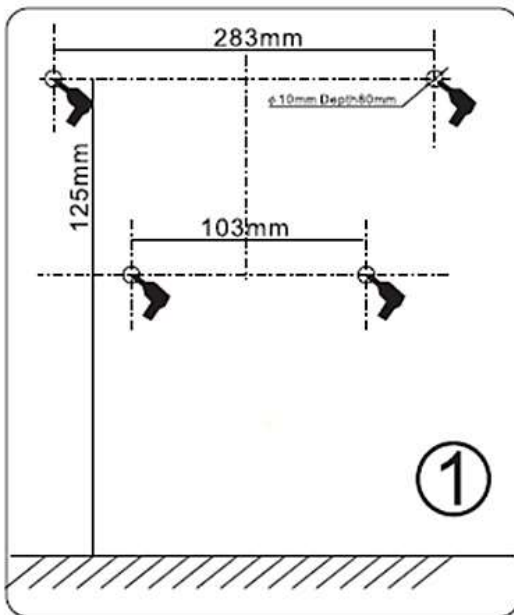

The photographs and line drawings of the products presented above are representational only. Metlam Australia Pty Ltd reserves the right to, and from time to time, make changes and improvements in design and dimensions.

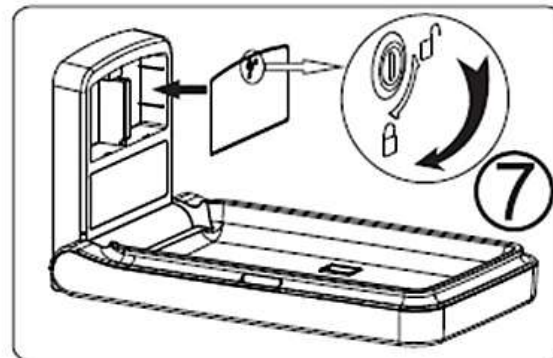
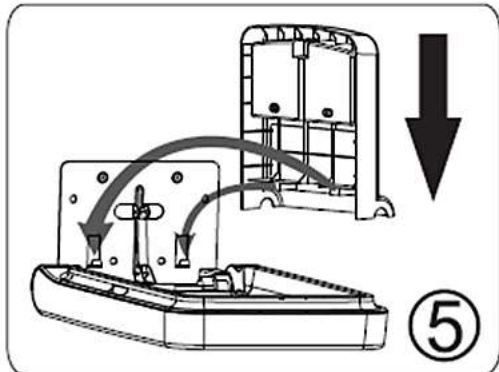
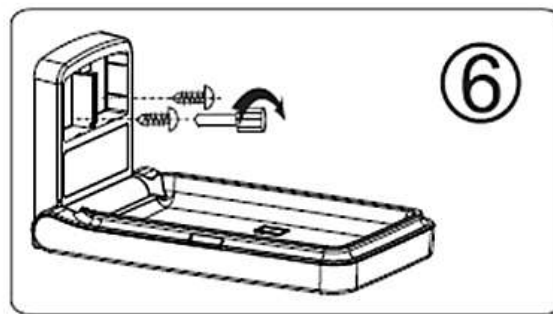
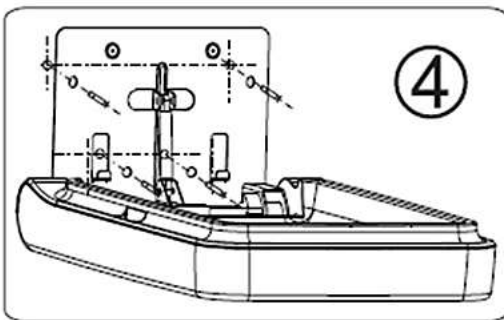
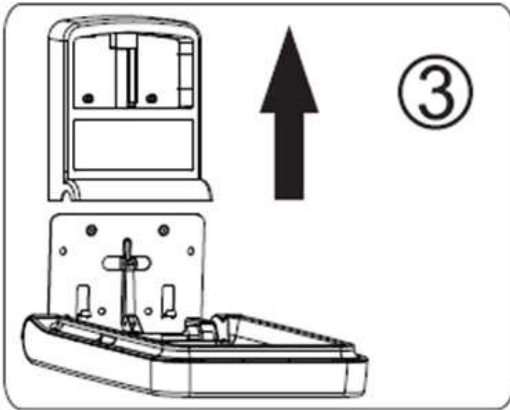

Warning

1. Do not leave the child unattended.
2. Take care of the baby, avoid serious injury from falling or sliding out.
3. Always use restraint belt when using.
4. Children are forbidden from hanging on the unit, there are risk of falling.
5. Designed for infants only, aged up to 12 months and weighing less than 11kgs.
6. Designed for baby care, it is strictly forbidden to use as an infant bed.
7. All assembly fittings should always be correctly tightened and checked regularly.
8. Be aware of the risk of open fires and other sources of strong heat, such as electric bar fires, gas fires etc, in the near vicinity of the changing unit.
9. Any additional or replacement parts shall only be obtained from the manufacturer or distributor.
10. Do not use the changing unit when any part is broken, torn or missing.



This product is AS1428.1 compliant (accessible compliant) when installed in accordance with the guidelines.

Installation Guidelines Sheet



The technical recommendations contained in this document are necessarily of a general nature and should not be relied on for specific applications without first securing competent advice. Whilst Metlam Australia Pty Ltd has taken all reasonable steps to ensure the information contained herein is accurate and current, it does not warrant the accuracy or completeness of the information and does not accept liability for errors or omissions. Any Commercial product should only be installed by a competent tradesperson and serviced/maintained by knowledgeable janitorial staff or competent people. Metlam Australia accepts no responsibility for any damage to product, walls or fixtures due to incorrect installation or maintenance of any of their products.

The photographs and line drawings of the products presented above are representational only.
Metlam Australia Pty Ltd reserves the right to, and from time to time, make changes and improvements in design and dimensions.