

ML8100H Horizontal Baby Change Station

Material Specifications

- Hi-density bacteria resistant Polyethylene body
- Stainless Steel hinge

Dimensions

- **Open:** 855mmW x 560mmH x 495mmD
- **Closed:** 855mmW x 560mmH x 107mmD

Installation Guidelines

AS1428.1 Standard - Baby Change Table Mounting Instructions

- *Baby Change Tables shall not encroach into the circulation space of any other toilet facility when in the folded position*
- *Baby Change Tables shall have a maximum height of 820mm and a minimum clearance of 720mm when in the open position (above finished floor level).*

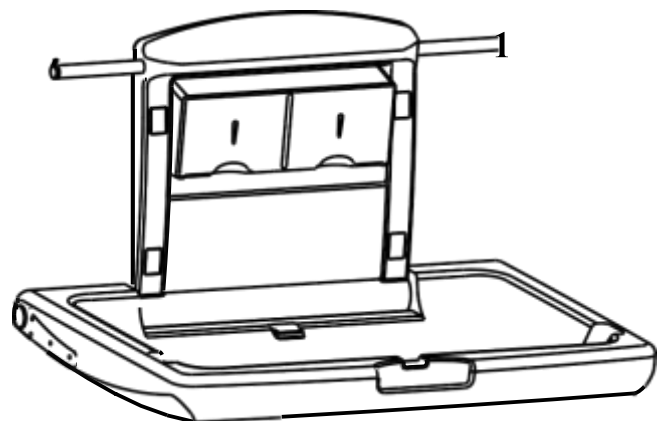
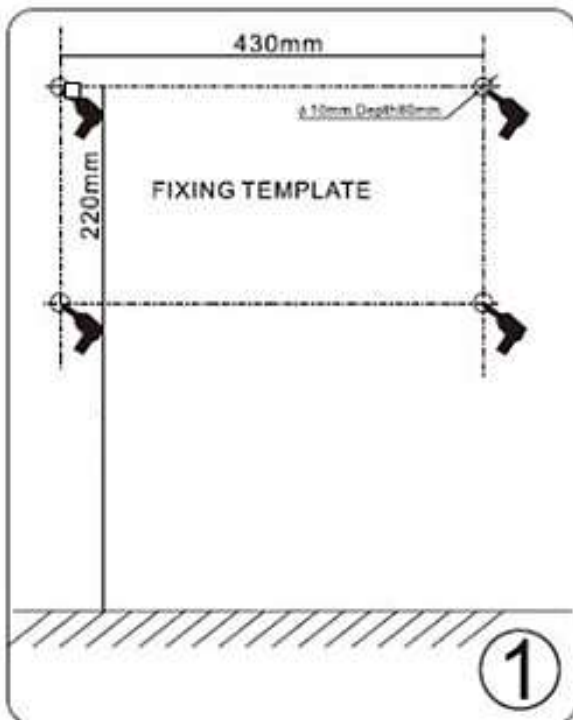

The photographs and line drawings of the products presented above are representational only. Metlam Australia Pty Ltd reserves the right to, and from time to time, make changes and improvements in design and dimensions.

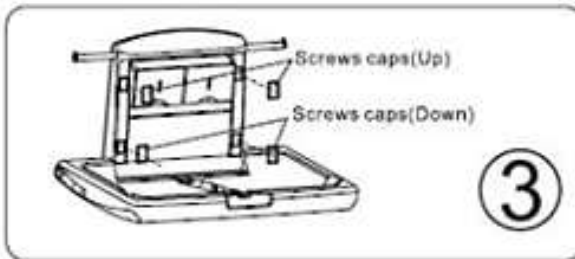
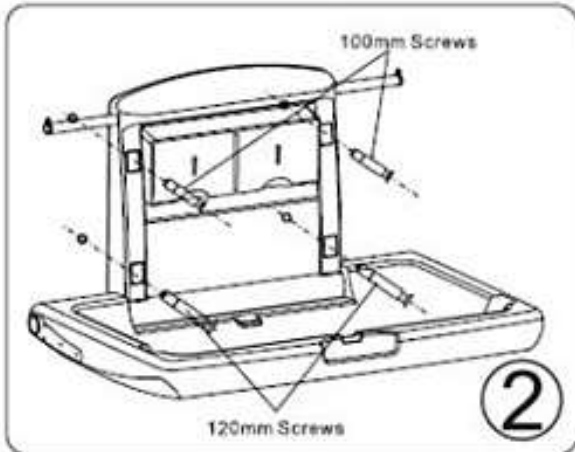

This product is AS1428.1 compliant (accessible compliant) when installed in accordance with the guidelines.

Warning

1. Do not move away from baby, never leave child unattended.
2. Take care of the baby to avoid serious injury from falling or sliding out.
3. Always use restraint belt when using.
4. Children are forbidden from hanging on the unit due to the risk of falling.
5. Designed for infants only, age up to 3years and weighing less than 20kgs.
6. Designed for baby care/ change, unit is strictly forbidden to use as an infant bed

The technical recommendations contained in this document are necessarily of a general nature and should not be relied on for specific applications without first securing competent advice. Whilst Metlam Australia Pty Ltd has taken all reasonable steps to ensure the information contained herein is accurate and current, it does not warrant the accuracy or completeness of the information and does not accept liability for errors or omissions. Any Commercial product should only be installed by a competent tradesperson and serviced/maintained by knowledgeable janitorial staff or competent people. Metlam Australia accepts no responsibility for any damage to product, walls or fixtures due to incorrect installation or maintenance of any of their products.

The photographs and line drawings of the products presented above are representational only.
Metlam Australia Pty Ltd reserves the right to, and from time to time, make changes and improvements in design and dimensions.