

ML2122 Concealed Stainless Steel Collapsible Coat Hook

Material Specifications

- #304 Stainless Steel Body
- Spring Loaded Pivot Hook with 12kg Drop-down Load Capacity

Mounting

- Concealed Screw Fix via rear mounting points

Dimensions

- 108mmW x 108mmH x 56mmD (hook in upright position)

Installation Guidelines

- *May be subject to Australian Building Code Regulations for able bodied and/or healthcare use.*
- *Unit **must** be affixed to secondary mounted panel, minimum 200mmW x 140mmL x 12mmH.*
- *It is recommended that the unit is installed whereby it clears any other fixtures by at least 100mm and not carry loads any greater than 12kg.*

1. Locate and drill 4 holes (70mm C to C or 100mm diagonal) into secondary mount panel and position metal security hex thread screws through panel and secure firmly into rear of hook body.
2. Secure secondary panel onto wall surface with appropriate screws and wall plugs.
3. Test the hook load for operational integrity to finish installation.

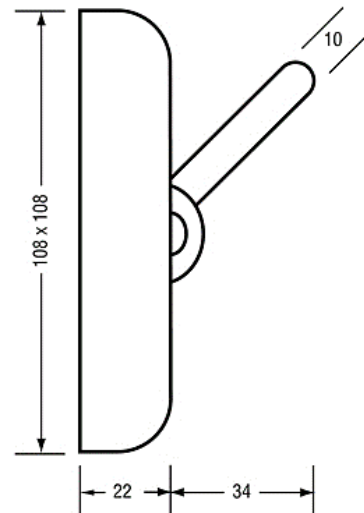

This product is AS1428.1 compliant (accessible compliant) when installed in accordance with the guidelines.

The technical recommendations contained in this document are necessarily of a general nature and should not be relied on for specific applications without first securing competent advice. Whilst Metlam Australia Pty Ltd has taken all reasonable steps to ensure the information contained herein is accurate and current, it does not warrant the accuracy or completeness of the information and does not accept liability for errors or omissions. Any Commercial product should only be installed by a competent tradesperson and serviced/maintained by knowledgeable janitorial staff or competent people. Metlam Australia accepts no responsibility for any damage to product, walls or fixtures due to incorrect installation or maintenance of any of their products.

The photographs and line drawings of the products presented above are representational only.
Metlam Australia Pty Ltd reserves the right to, and from time to time, make changes and improvements in design and dimensions.