RIVERS MODEL D TWO POINT LOCK – OPEN OUT DOOR

1. Mark centreline of Lock across inside of door at desired height (nominally 1000mm from floor to centreline of Lock Body). (Fig. 1)
2. Mark position for end of lock (with door closed) on opening side 10mm from frame (23mm for Series 4 & 5 Locks). (Fig. 1)
3. Locate the correct drilling template. Note that a different template applies to the standard cylinder shield and the Key & Lever interface.
4. Place the template on the centreline of lock marked on door (step 1), and mark the two lock body mounting holes at opening side of door. If external key access is provided, mark the cluster of five holes.
5. Drill two mounting holes 10mm diameter through door, then counter bore each 15mm diameter x 25mm deep from the outside.
6. Cut four pieces of the supplied M8 threaded rod to length (length = door thickness + 35mm). Deburr ends & screw partway into nut plates.
7. Fit nut plate assembly to door from outside at opening side of door & position lock body over the threaded rods.
8. Mark hinge side mounting holes
9. Remove lock. Drill two 10mm diameter holes and counter bore 15mm diameter x 25mm deep from front. (Fig. 5 & 6)
10. Fit lock to door with the two nut plate assemblies, dome nuts & washers. Tighten all nuts. Do not over tighten. (Fig. 7)
11. With door closed, activate the Locking Bars so that they are touching on the door frame. Mark position of locking bars on frame (Fig. 8)
12. Drill a 12mm diameter hole in both sides of frame at top & bottom of locking bar. Use a small cutting wheel to splice between top & bottom holes, either side. (Fig. 9 & 10) This will create a slot in the frame to accept Locking Bars. If frame is concrete filled, drill out masonry to a depth so that Locking Bars will not 'bottom out' when fully extended.
13. Clean edges of slots & ensure smooth action of Lock when locking/unlocking.
14. Position the striker plates over the locking bars and against the frame, hold in position & fix in place with self-tapping screws supplied. For Series 4 & 5 Locks, care must be taken in fixing the strike/ramp on the opening side to ensure that the dome nut on the trigger runs up the ramp & comes to rest on the flat as the locking bars are released.
15. Ensure Lock operates smoothly & without resistance. Excessive force should not be required to activate lock. Inside Lever Handle must operate in a downward motion & allow escape at all times.

PLEASE NOTE: RIVERS RESERVES THE RIGHT TO CHANGE SPECIFICATIONS WITHOUT NOTICE

RIVERS LOCKS SHOULD ONLY BE MOUNTED ONTO SOLID CORE DOORS

MODEL D LOCK - OPEN OUT DOOR

23

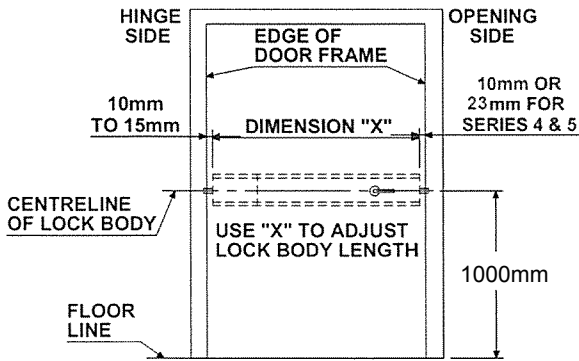

FIGURE 1

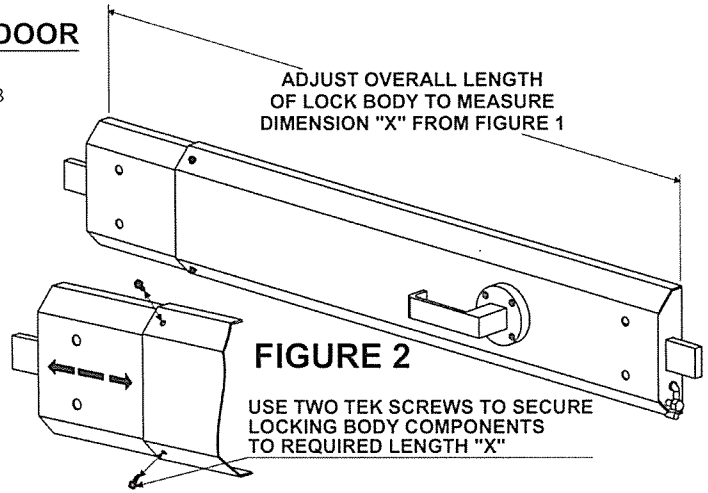

FIGURE 2

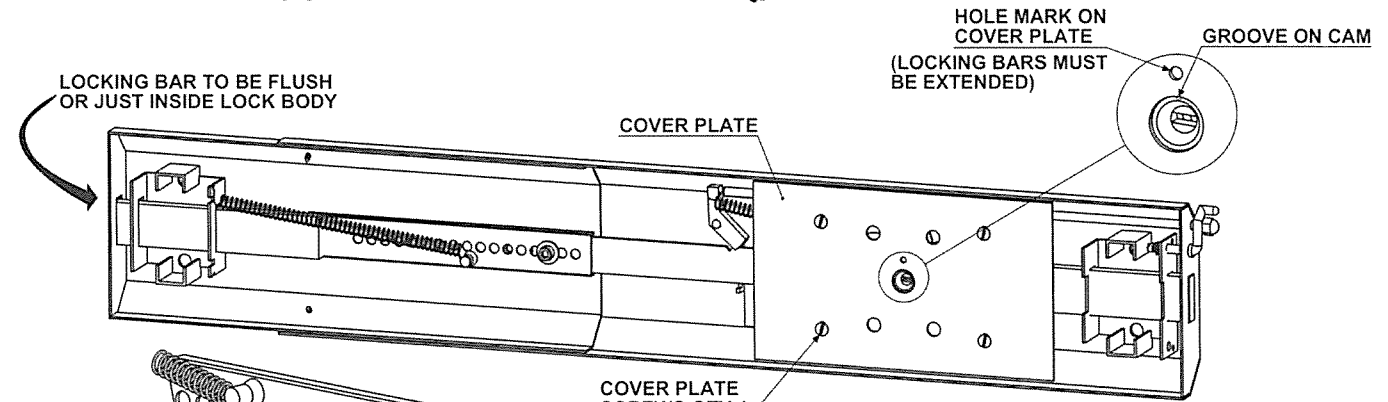

FIGURE 3

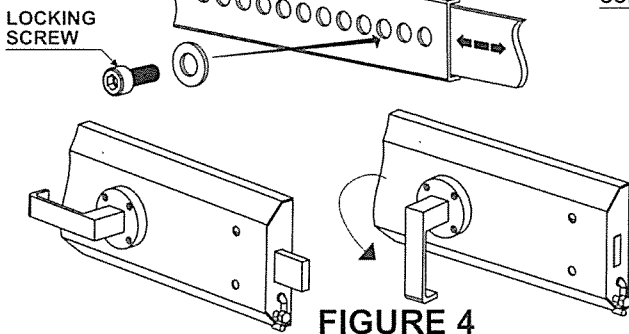

FIGURE 4

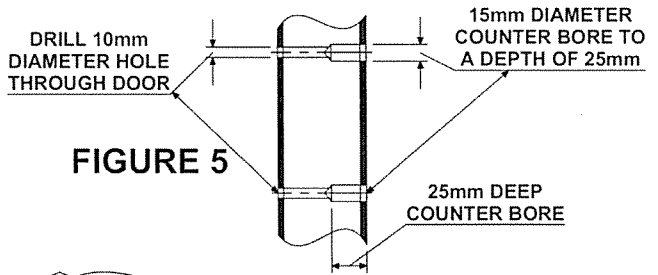

FIGURE 5

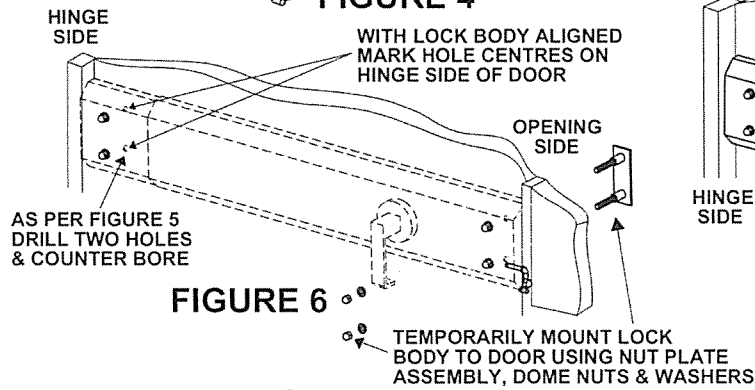

FIGURE 6

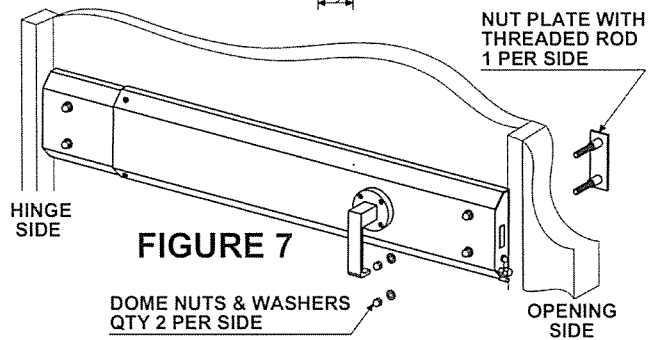

FIGURE 7

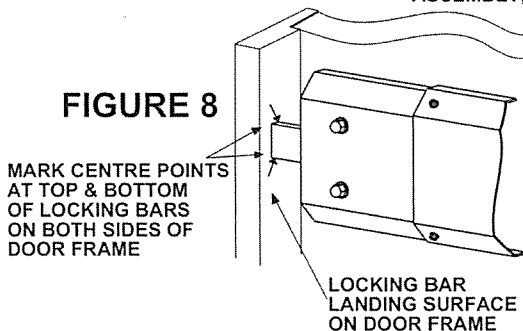

FIGURE 8

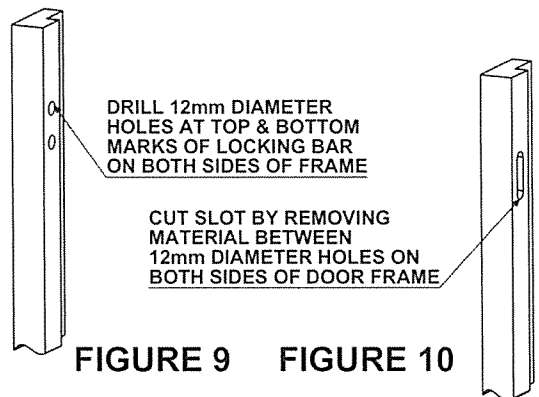

FIGURE 9 **FIGURE 10**

RIVERS MODEL D TWO POINT LOCK – OPEN OUT DOOR

LOCKS SUPPLIED ADJUSTABLE

1. Mark position for end of lock (with door closed) on hinge side 10-15mm from frame. (Fig. 1)
2. Measure the distance between the two marks & adjust lock body to that length. Fix into position using 2 x tek screws. (Fig. 2)
3. Remove locking screw from perforated locking bar & adjust locking bar in extension end of lock such that with the lock in the retracted position the locking bar is flush with (or just inside of) the end of the lock body. Refit screw in adjusted position & tighten. (Fig. 3)
4. Ensure the lever handle operates in a downward motion to retract locking bars. (Fig. 4) If it does not the 'hand' of the lock needs to be changed. This can be changed with a 'Change of Handing Kit' ordered separately.

INSTALLING KEY & LEVER UNIT/CYLINDER SHIELD – SERIES 4KL & SERIES 5

1. Drill four mounting holes 10mm diameter through door and then counter bore each 15mm diameter x 25mm deep from the outside.
2. For standard cylinder shield – drill lock cylinder hole 32mm diameter through door. Note that the 32mm diameter hole for the lock cylinder is not on the centreline.
3. For Key & Lever interface – drill key steel hole 15mm diameter through door.
4. Fit the cylinder shield assembly/key & lever to the outside of the door using screws provided. Trim cylinder tail/square bar to project 20-22mm from inside face of door.
5. Key must be in neutral position i.e. removable. Check that the groove on the cam aligns with marking on Backing Plate when Locking Bars are extended. (Fig. 3) Ensure that the cylinder tail/square bar is aligned with the slot in the cam. Fit dome nuts and washers. Align lock and mark mounting hole positions for hinge side mounting holes. (Fig. 6)
6. For Series 4KL, be aware that alignment is crucial. The key steel that turns from the external lever handle must freely move when the handle is turned in the downward motion and when it is released. If alignment of the cam on the key steel is not correct, it may prevent the key from being removed from the lock once it has been unlocked.

PLEASE NOTE: RIVERS RESERVES THE RIGHT TO CHANGE SPECIFICATIONS WITHOUT NOTICE

RIVERS LOCKS SHOULD ONLY BE MOUNTED ONTO SOLID CORE DOORS

MODEL D LOCK - OPEN OUT DOOR

23

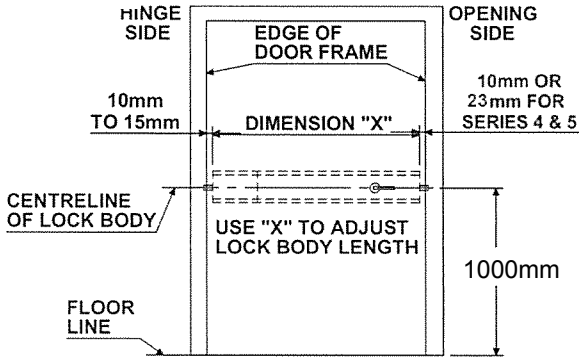

FIGURE 1

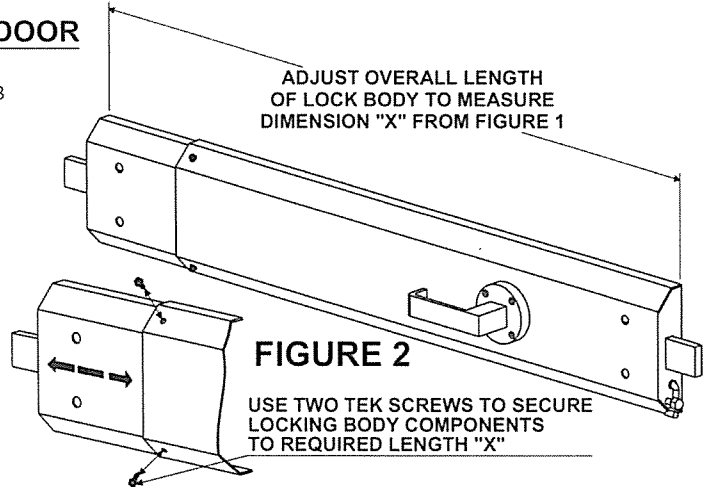

FIGURE 2

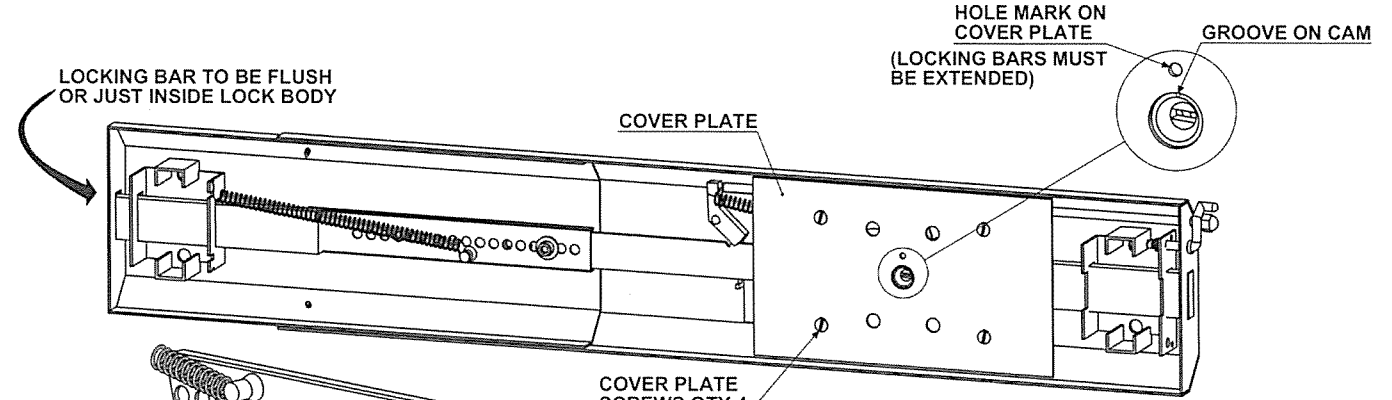

FIGURE 3

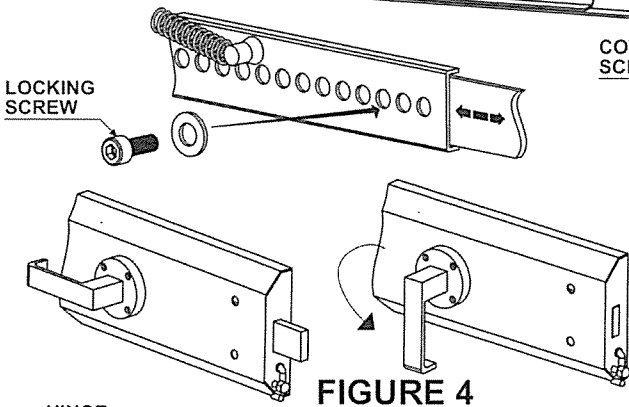

FIGURE 4

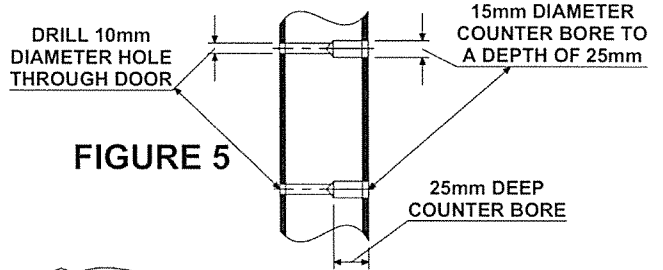

FIGURE 5

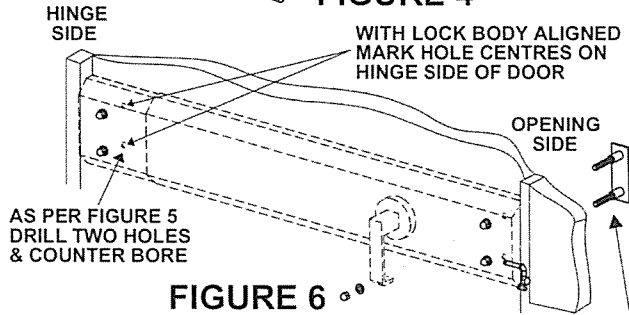

FIGURE 6

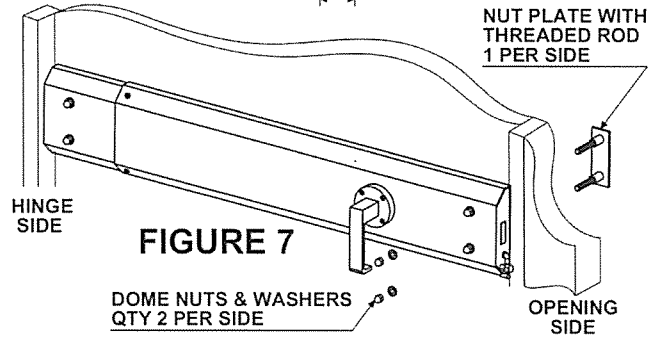

FIGURE 7

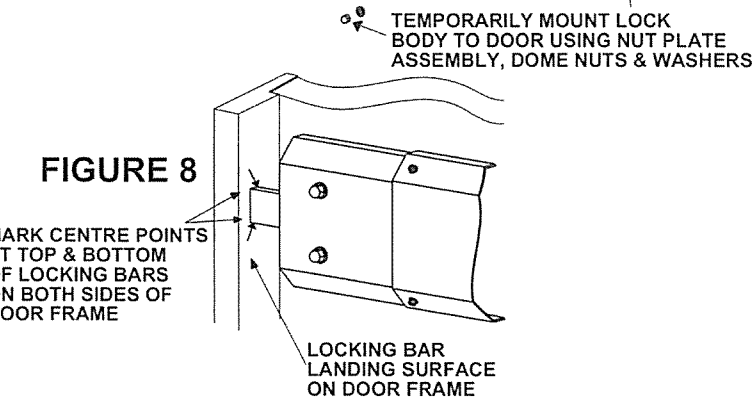

FIGURE 8

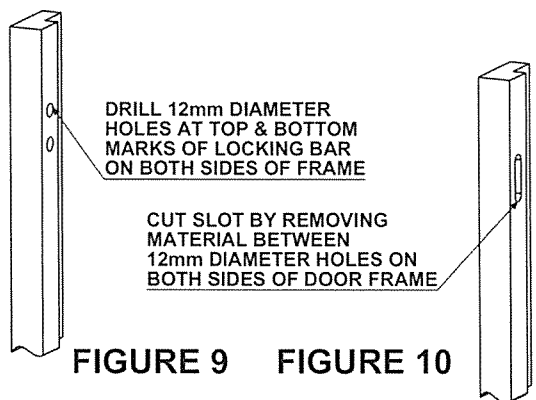

FIGURE 9 **FIGURE 10**

RIVERS MODEL D TWO POINT LOCK – OPEN IN DOOR

1. Mark centreline of Lock across inside of door at desired height (nominally 1000mm from floor to centreline of Lock Body). (Fig. 1)
2. Mark position for end of lock (with door closed) on opening side 10mm from edge of door. (Fig. 1)
3. Locate the correct drilling template. Note that a different template applies to the standard cylinder shield and the Key & Lever interface.
4. Place the template on the centreline of lock marked on door (step 1), and mark the two lock body mounting holes at opening side of door. If external key access is provided, mark the cluster of five holes.
5. Drill two 3mm diameter x 15mm deep holes from the inside, for mounting lock body.
6. Fix lock using coach screws & washers supplied (do not over tighten) & mark position for hinge side mounting holes.
7. Remove lock & drill two 3mm diameter x 15mm deep holes from the inside for coach screws.
8. Fit lock to door with the four coach screws & washers. Tighten all screws. Do not over tighten. (Fig. 5)
9. With door closed, activate the Locking Bars so that they are extended over the door frame. Mark hole positions in keepers onto frame. (Fig. 8)
10. Drill outer keeper holes using a 4mm diameter drill through face of frame. Drill inner keeper holes using a 10mm diameter drill right through the width of the frame. Use a masonry drill if frame is concrete filled. Counter bore 15mm diameter x 25mm deep from outside face of frame. (Fig. 7)
11. Fit the keepers to the frame using 14G self-tapping screws in outer holes. Add spacers provided behind keepers if necessary to obtain freedom of movement. (Fig. 8) For Series 4 & 5 Locks, care must be taken in fixing the strike/ramp on the opening side to ensure that the dome nut on the trigger runs up the ramp & comes to rest on the flat as the locking bars are released.
12. Cut four pieces of the M8 threaded rod to length (length = frame thickness + 15mm). Deburr ends & screw partway into nut plates.
13. Fit the nut plates with threaded rod through the frame (from the outside). Run the dome nuts & washers onto the threaded rod & tighten. (Fig. 9)
14. Fit door stop (not supplied), if necessary, to prevent damage to the hinge side keeper.
15. Ensure Lock operates smoothly & without resistance. Excessive force should not be required to activate lock. Inside Lever Handle must operate in a downward motion & allow escape at all times.

PLEASE NOTE: RIVERS RESERVES THE RIGHT TO CHANGE SPECIFICATIONS WITHOUT NOTICE

RIVERS LOCKS SHOULD ONLY BE MOUNTED ONTO SOLID CORE DOORS

MODEL D LOCK - OPEN IN DOOR

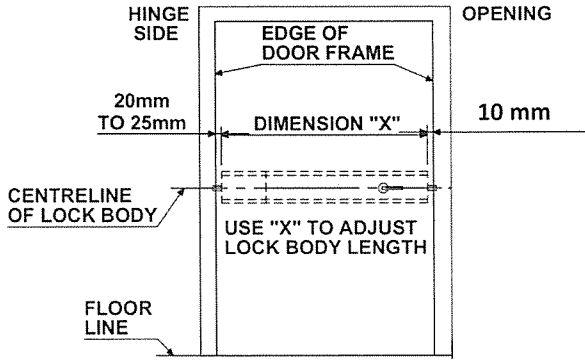

FIGURE 1

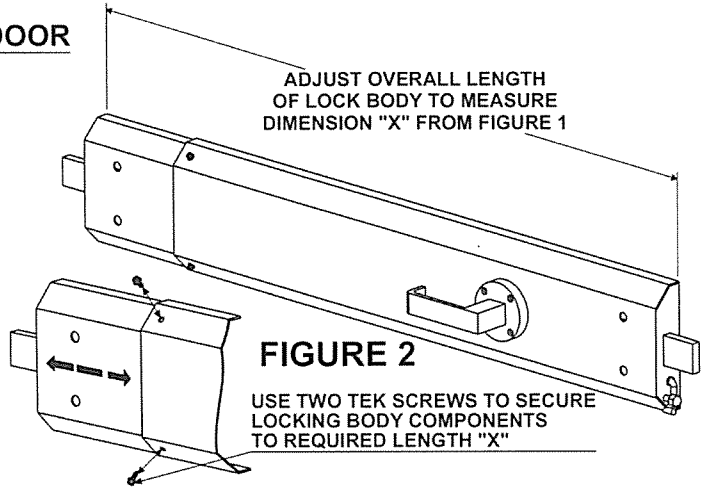

FIGURE 2

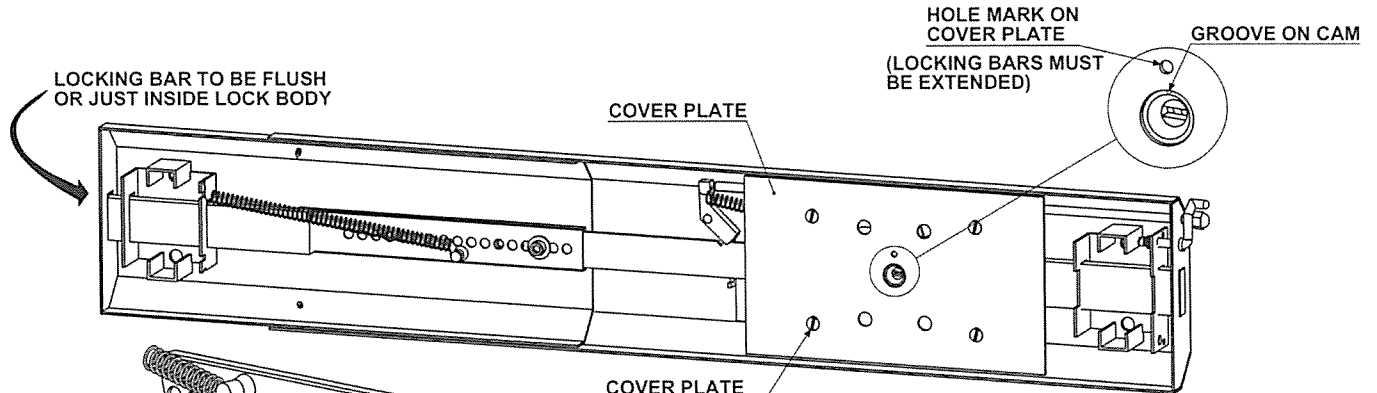

FIGURE 3

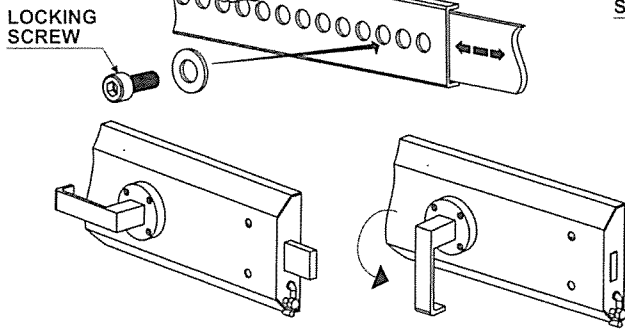

FIGURE 4

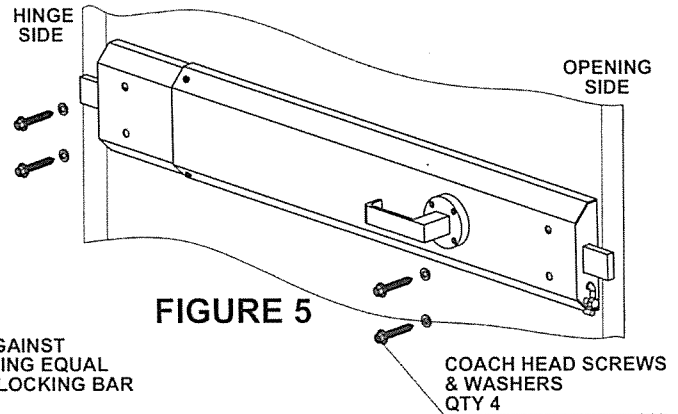

FIGURE 5

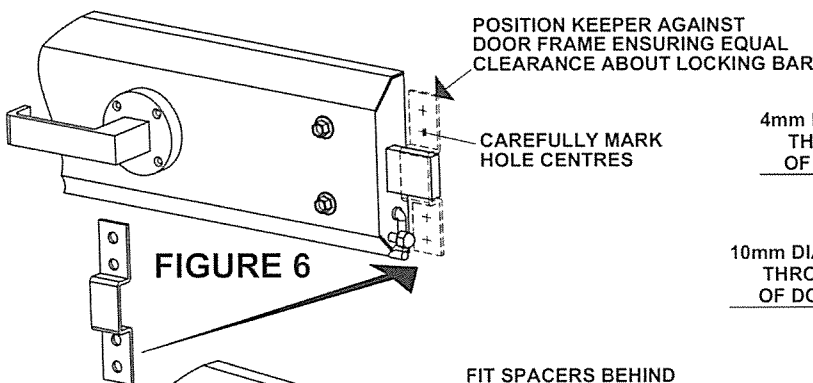

FIGURE 6

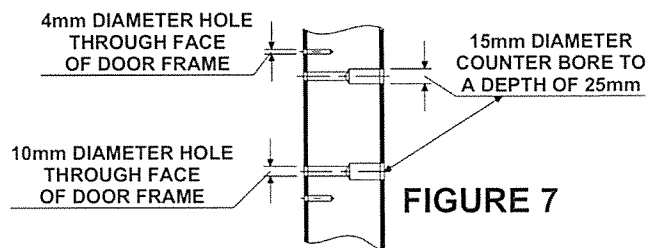

FIGURE 7

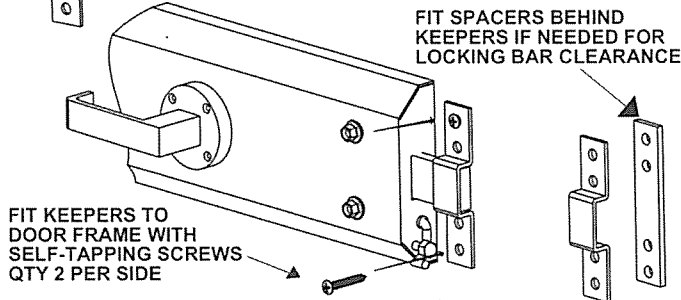

FIGURE 8

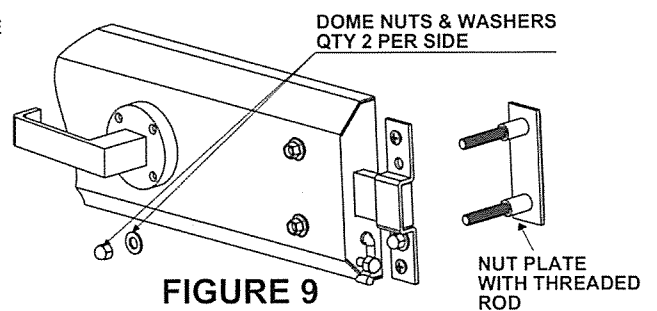

FIGURE 9

RIVERS MODEL D TWO POINT LOCK – OPEN IN DOOR

LOCKS SUPPLIED ADJUSTABLE

1. Mark position for end of lock (with door closed) on hinge side 20-25mm from edge of door. (Fig. 1)
2. Measure the distance between the two marks & adjust lock body to that length. Fix into position using 2 x tek screws. (Fig. 2)
3. Remove locking screw from perforated locking bar & adjust locking bar in extension end of lock such that with the lock in the retracted position the locking bar is flush with (or just inside of) the end of the lock body. Refit screw in adjusted position & tighten. (Fig. 3)
4. Ensure the lever handle operates in a downward motion to retract locking bars. (Fig. 4) If it does not the 'hand' of the lock needs to be changed. This can be changed with a 'Change of Handing Kit' ordered separately.

INSTALLING KEY & LEVER UNIT/CYLINDER SHIELD – SERIES 4KL & SERIES 5

1. Drill four mounting holes 10mm diameter through door and then counter bore each 15mm diameter x 25mm deep from the outside.
2. For standard cylinder shield – drill lock cylinder hole 32mm diameter through door. Note that the 32mm diameter hole for the lock cylinder is not on the centreline.
3. For Key & Lever interface – drill key steel hole 15mm diameter through door.
4. Fit the cylinder shield assembly/key & lever to the outside of the door using screws provided. Trim cylinder tail/square bar to project 20-22mm from inside face of door.
5. Key must be in neutral position i.e. removable. Check that the groove on the cam aligns with marking on Backing Plate when Locking Bars are extended. (Fig. 3) Ensure that the cylinder tail/square bar is aligned with the slot in the cam. Fit dome nuts and washers. Align lock and mark mounting hole positions for hinge side mounting holes. (Fig. 6)
6. For Series 4KL, be aware that alignment is crucial. The key steel that turns from the external lever handle must freely move when the handle is turned in the downward motion and when it is released. If alignment of the cam on the key steel is not correct, it may prevent the key from being removed from the lock once it has been unlocked.

PLEASE NOTE: RIVERS RESERVES THE RIGHT TO CHANGE SPECIFICATIONS WITHOUT NOTICE

RIVERS LOCKS SHOULD ONLY BE MOUNTED ONTO SOLID CORE DOORS

MODEL D LOCK - OPEN IN DOOR

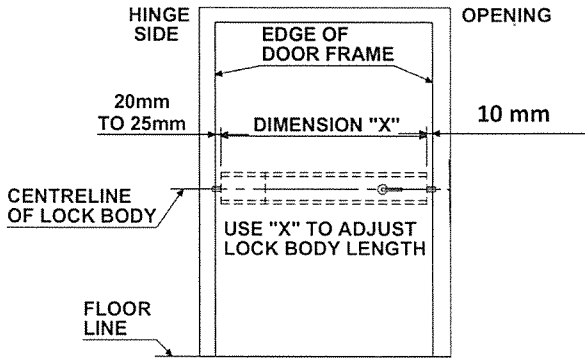

FIGURE 1

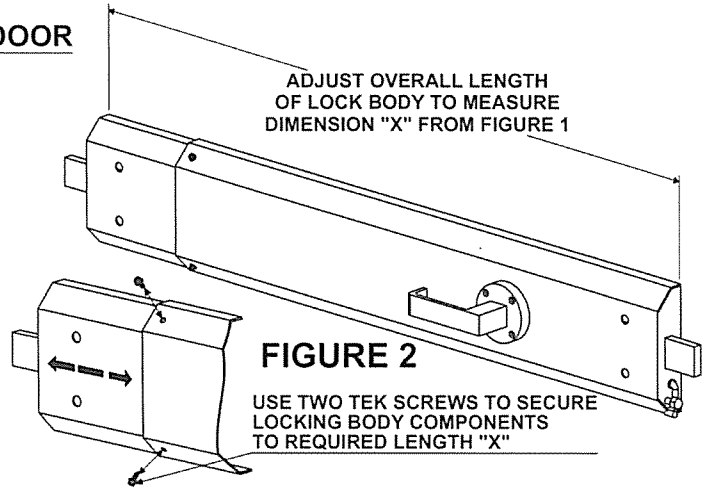

FIGURE 2

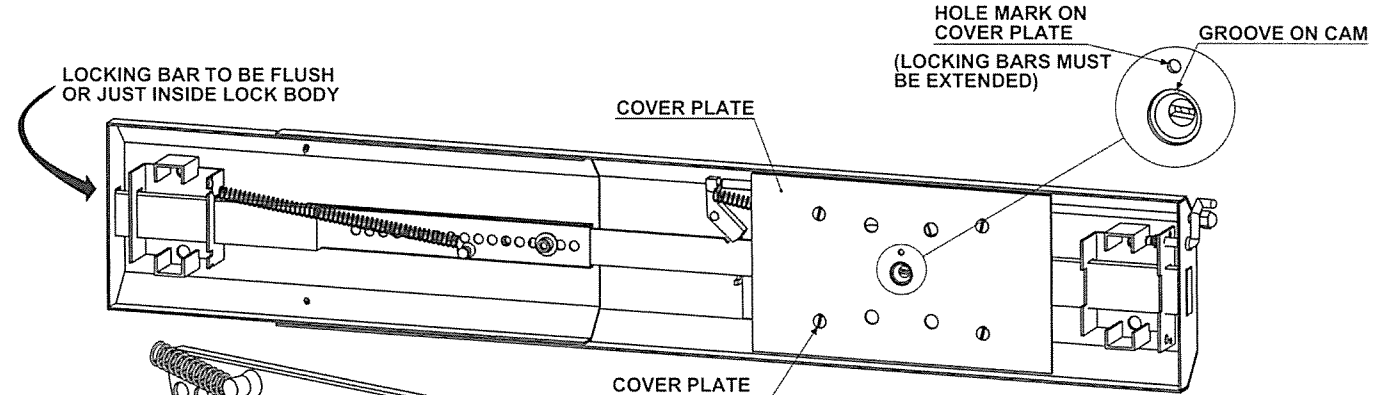

FIGURE 3

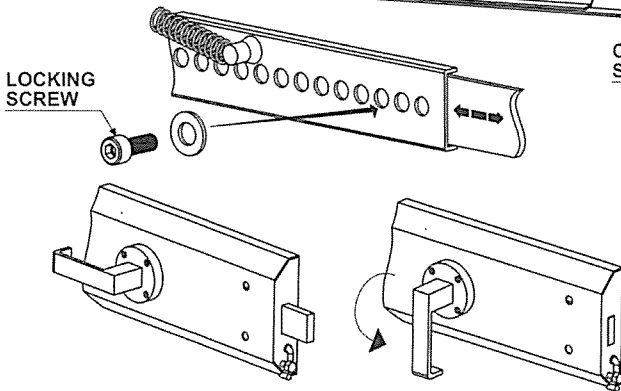

FIGURE 4

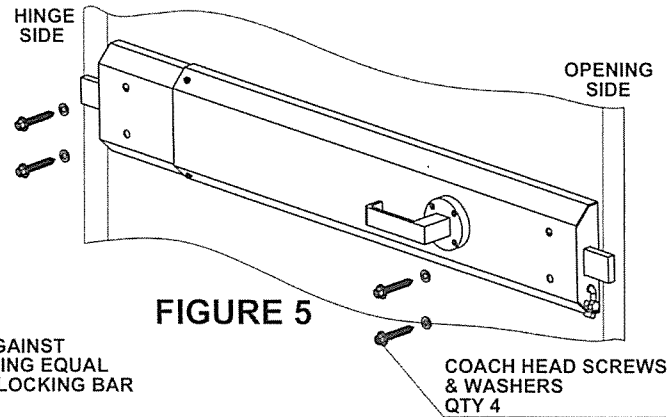

FIGURE 5

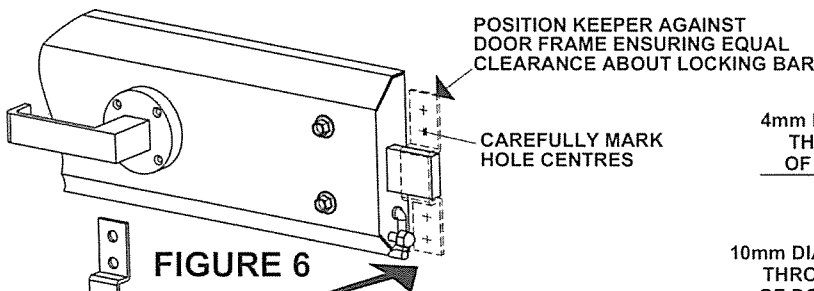

FIGURE 6

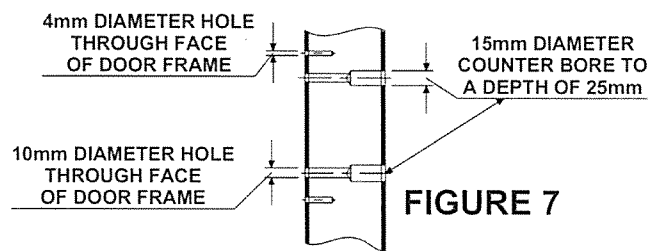

FIGURE 7

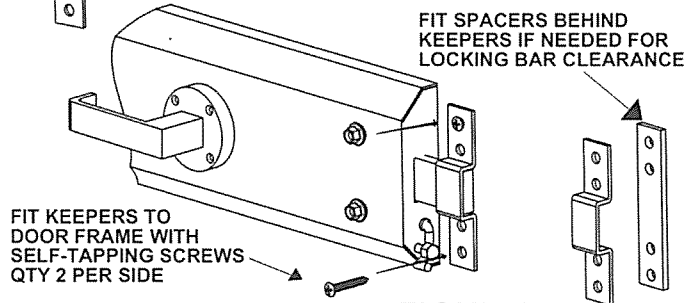

FIGURE 8

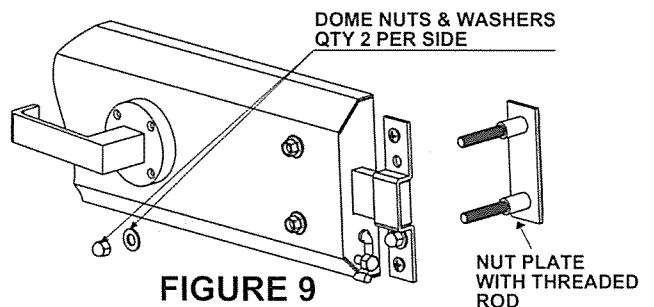

FIGURE 9