

## PRODUCT INFORMATION

### DIMENSIONS

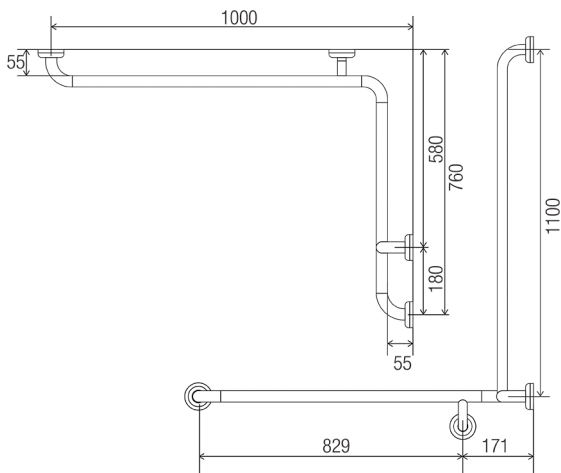

Drawn RH (Right Hand)

### INDICATIVE IMAGE



## CLAM FLANGE® - SHOWER GRAB RAILS

### Product Code - Finish

- CF 711 PS RH - Polish Supreme™

### Features

- 760 mm x 1000 mm x 1100 mm
- 78 mm pre-formed domed CLAM FLANGE®
- Clam plate is fully welded to 32 mm rail for maximum strength
- Clam flange cover is a firm press fit to clam plate
- Fabricated from 304 stainless steel
- Inside of grab rail has been cleaned and free of unsanitary oil and dirt produced through fabrication processes
- Stainless steel fixing screws supplied

### Compliance

- Complies with clause 17 of AS 1428.1-2009 for design and construction of grab rails

### Optional Extras



- SD 032



- HC 024



- HC 932

### Warranty

See Con-Serv warranty policy for full details.

CON-SERV CORPORATION AUSTRALIA PTY. LTD.

17 Glentanna Street, Kedron · Qld. 4031 Australia

Phone: +61 (0)7 3630 5744 · Fax: +61 (0)7 3630 5755 · Email: mail@con-serv.com.au · www.con-serv.com.au