

SURFACE MOUNTED SHELF

MODEL 9094

Options:

9094-18 - 450mm

9094-24 - 600mm



SHELF 9094

- Satin finish stainless steel
- Vandal resistant escutcheons
- Model 9095 - polished stainless steel

Overall Dimensions
 450mm W x 50mm H x 127mm D Shelf
 with 159mm projection
 Escutcheons: 50mm x 50mm

CONSTRUCTION:

UNITS: Fabricated of type 304 stainless steel with exposed surfaces in architectural satin finish.

ESCUTCHEONS: Are 50mm W x 50mm H, where applicable, unless otherwise indicated.

INSTALLATION:

Secure mounting bracket to wall with screws (included) at holes provided. With escutcheon set screw on the bottom, align top end of escutcheon interior to top of wall bracket.

Pivot escutcheon plate(s) down into position and tighten concealed set screw to lock unit in place.

GUIDE SPECIFICATION:

Surface mounted shelf shall be fabricated of type 304 stainless steel with exposed surfaces in architectural satin finish.

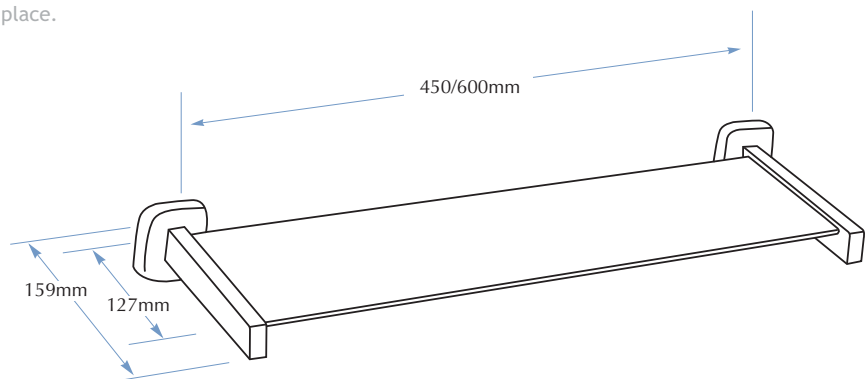
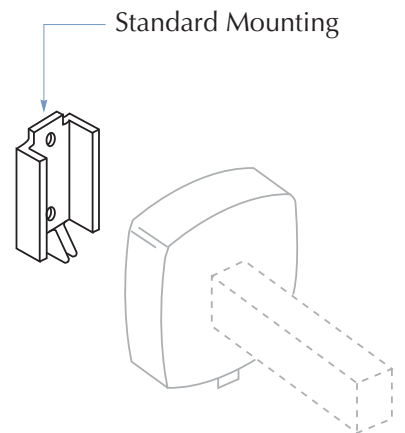

TOLL FREE 1300 364 561

The manufacturer reserves the right to make changes in design and material without formal notice and without incurring obligation.

Bradley
 AUSTRALIA.COM