

MODEL 832-005-3030

SURFACE MOUNTED RIGHT HAND GRAB RAIL

Options:

- 832-006-3030 Left Hand
- 2 Peened (Safety Grip)
- 4 Polished
- 6 Powdercoated
- 51 with Toilet Roll Holder

www.bradleyaustralia.com

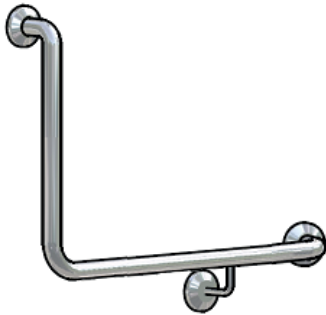

PRODUCT FEATURES:

- 31.8mm diameter
- Concealed fixing
- All dimensions centre to centre
- Standard - 750mm x 750mm at 90° (under slung)
- For special sizes nominate:
Horizontal (A) =
Vertical (B) =

PRODUCT DATA:

CONSTRUCTION:

FLANGES: Fabricated of type 304 (18-8), 80mm dia. 13 gauge stainless steel.

ESCUTCHEONS: Fabricated of type 304 (18-8), 22 gauge stainless steel.

One-piece drawn construction with exposed surfaces in architectural satin finish. Snap over flanges to conceal mounting screws.

TUBING: Fabricated of type 304 (18-8), 32mm (1-1/4") O.D.

18 gauge stainless steel, seamless construction with exposed surfaces in architectural satin finish. Bent ends of tubing pass through the flanges and are heliarc welded into a single structural unit for maximum strength. Intermediate supports are contour cut and joined by heliarc welding to form an integral part of the grab bar. All welds ground and polished to blend. Mandrel bending process maintains uniform bar diameter.

STRENGTH

When properly mounted, all Bradley heavy duty grab bar systems meet or exceed the requirements of Australian Standard AS 1428.1

INSTALLATION:

Secure to wall where adequate in-wall backing exists. Use bar as template to locate mounting holes. Drill holes and set anchors as appropriate. Mount grab rail and secure mounting screws. Snap escutcheons into place.

GUIDE SPECIFICATION:

Grab bar shall be fabricated of type 304 satin finish stainless steel with concealed mounting flanges in sizes and configurations as indicated.

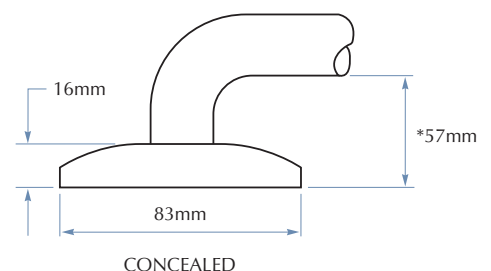
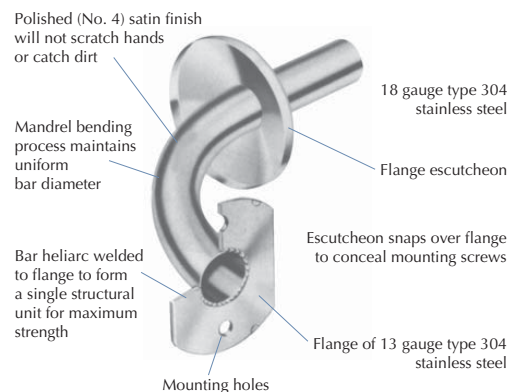
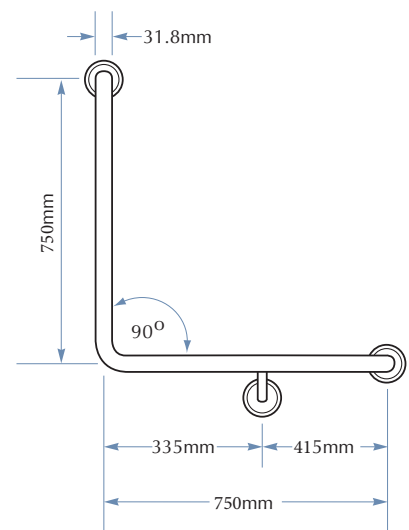

*50-60mm wall clearance required under most building design codes