

RIVERS 420 FOUR POINT LOCK – OPEN IN DOOR

1. Mark centreline of Lock across inside of door at desired height (nominally 1000mm from floor to centreline of Handle). (Fig. 1)
2. Remove cover from Lock Body.
3. Position Lock onto door at pre-determined height & such that the clearance between Lock Body & edge of door is approximately 5-10 mm at opening side & 20-25mm at hinge side. (Fig. 1 & 2) Fix Lock to door using only three self-tapping screws.
4. Mark four Cylinder Shield holes & Cylinder centre using the Lock Backing Plate as a template. (Fig. 3)
5. Remove Lock Body from door & drill four 10mm diameter holes through door, then counter bore each 15mm diameter x 25mm deep from the outside. Drill Lock Cylinder hole 32mm diameter. (Fig. 4 & 5)
6. Mount Lock Body to door using self-tapping screws provided.
7. Fit Cylinder Shield Assembly to door using screws provided. Fix through lock body. (Fig. 7)
8. With the Locking Bars extended (i.e. locked position) & the key removed from the Cylinder, ensure that the Cam (that accepts the Cylinder Tail) is oriented so the two marks are lined up (one on the Cam, the other on the cover plate.). This is critical for the Lock to function properly.
9. With door closed, activate the Locking Bars so that they are extended over the door frame. Position the keepers over the locking bars & against the frame, ensuring that there is equal clearance around the bars. Fix them in position with screws supplied. (Fig. 7)
10. Fit outside Handle & Spindle to door using screws provided.
11. At this point check the operation of the Cam Locking Bar. Ensure when the outside Lever Handle is moved upwards to the horizontal position, the Cam Locking Bar falls freely into the cut out in the Inner Cam Plate. (Fig. 6)
12. Ensure correct Lock operation. Inside Handle must disengage Locking Bars at all times (for escape), while the outside Handle should not operate unless the Cylinder has been unlocked with the key.
13. Replace Lock Body Cover.
14. Screw inside Lever Handle on.
15. Ensure Lock operates smoothly & without resistance. Excessive force should not be required to activate Lock. Inside Lever Handle must operate in a downward motion & allow escape at all times.

PLEASE NOTE: RIVERS RESERVES THE RIGHT TO CHANGE SPECIFICATIONS WITHOUT NOTICE

RIVERS LOCKS SHOULD ONLY BE MOUNTED ONTO SOLID CORE DOORS

RIVERS 420 FOUR POINT LOCK – OPEN OUT DOOR

1. Mark centreline of Lock across inside of door at desired height (nominally 1000mm from floor to centreline of Handle). (Fig. 1)
2. Remove cover from Lock Body.
3. Position Lock onto door at pre-determined height & such that the clearance between Lock Body & door jamb is equal on both sides. (Fig. 1) Fix Lock to door using only three self-tapping screws.
4. Mark four Cylinder Shield holes & Cylinder centre using the Lock Backing Plate as a template. (Fig. 3)
5. Remove Lock Body from door & drill four 10mm diameter holes through door, then counter bore each 15mm diameter x 25mm deep from the outside. Drill Lock Cylinder hole 32mm diameter. (Fig. 4 & 5)
6. Mount Lock Body to door using self-tapping screws provided.
7. Fit Cylinder Shield Assembly to door using screws provided. Fix through Lock body. (Fig. 7)
8. With the Locking Bars extended (i.e. locked position) & the key removed from the Cylinder, ensure that the Cam (that accepts the Cylinder Tail) is oriented so the two marks are lined up (one on the Cam, the other on the cover plate.) The door will need to be open to do this. This is critical for the Lock to function properly.
9. With door closed, activate the Locking Bars so that they are touching on the dor frame. Mark position of locking bars on frame. (Fig. 8)
10. Drill a 12mm diameter hole in frame at top & bottom of each Locking Bar position. (Fig. 9) Use a small cutting wheel to splice between top & bottom holes, either side. (Fig. 10) This will create a slot in the frame to accept Locking Bars. If frame is concrete filled, drill out masonry to a depth so the Locking Bars will not 'bottom out' when fully extended.
11. Clean edges of slots & ensure smooth action of Lock when locking/unlocking.
12. Position striker plates over the locking bars and against the frame, hold in position & fix in place with self-tapping screws supplied.
13. Fit outside Handle & Spindle to door using screws provided.
14. Ensure correct Lock operation. Inside Handle must disengage Locking Bars at all times (for escape), while the outside Handle should not operate unless the Cylinder has been unlocked with the key.
15. Replace Lock Body Cover and install inside Handle.
16. Ensure Lock operates smoothly & without resistance. Excessive force should not be required to activate lock. Inside Lever Handle must operate in a downward motion & allow escape at all times.

PLEASE NOTE: RIVERS RESERVES THE RIGHT TO CHANGE SPECIFICATIONS WITHOUT NOTICE

RIVERS LOCKS SHOULD ONLY BE MOUNTED ONTO SOLID CORE DOORS

410/420 FOUR POINT LOCK-OPEN OUT DOOR

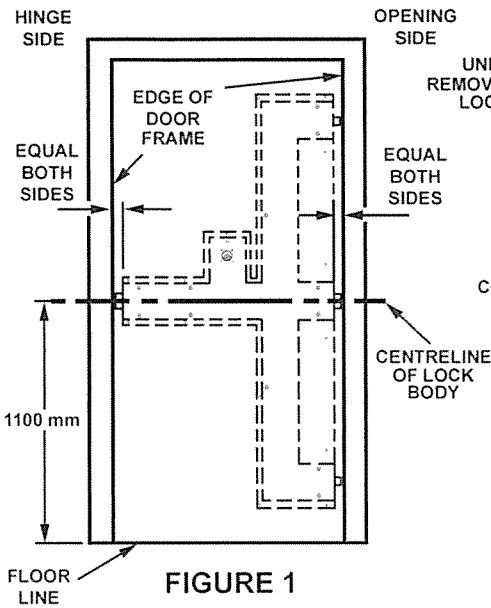

FIGURE 1

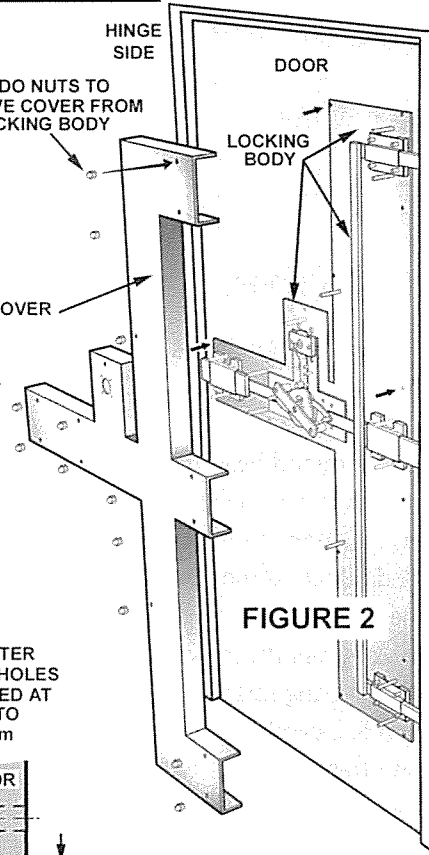

FIGURE 2

OPENING SIDE
LOCKING BODY MOUNTS TO DOOR USING SELF-TAPPING SCREWS
WHEN CYLINDER MOUNTING HOLES ARE TO BE MARKED ONTO DOOR, USE ONLY 3 SELF-TAPPING SCREWS, TEMPORARILY, TO MOUNT LOCK TO DOOR OR, FOR LOCKS WITHOUT CYLINDERS, USE ALL SELF TAPPING SCREWS TO PERMANENTLY MOUNT LOCK TO DOOR
USING BACKING PLATE AS A TEMPLATE, MARK FOUR CYLINDER MOUNTING HOLES & CYLINDER CENTRE ON DOOR

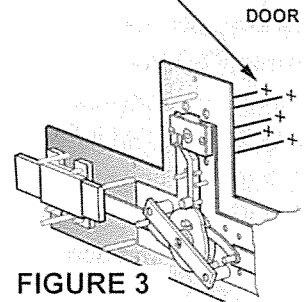

FIGURE 3

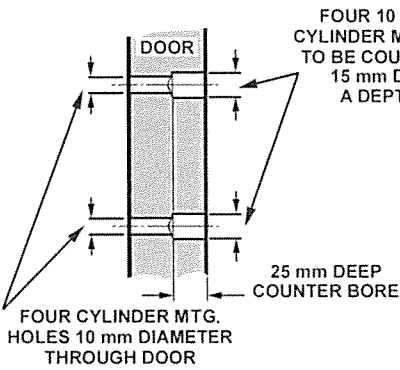

FIGURE 4
TYPICAL SECTION
FOUR CYLINDER
MOUNTING HOLES

FOUR 10 mm DIAMETER CYLINDER MOUNTING HOLES TO BE COUNTER BORED AT 15 mm DIAMETER TO A DEPTH OF 25 mm

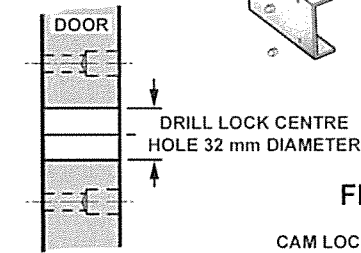

FIGURE 5

FIGURE 6

CAM LOCKING BAR MUST DROP FREELY INTO CUT OUT IN THE INNER CAM PLATE WHEN HANDLE IS HORIZONTAL
CAM LOCKING BAR
CAM LOBE TO POINT AWAY FROM FROM LOCKING BAR

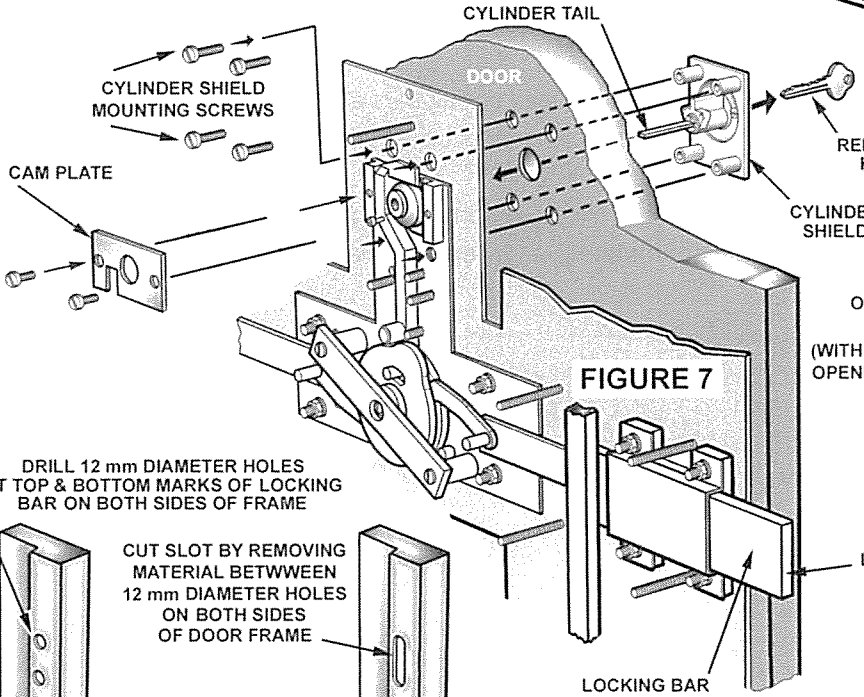
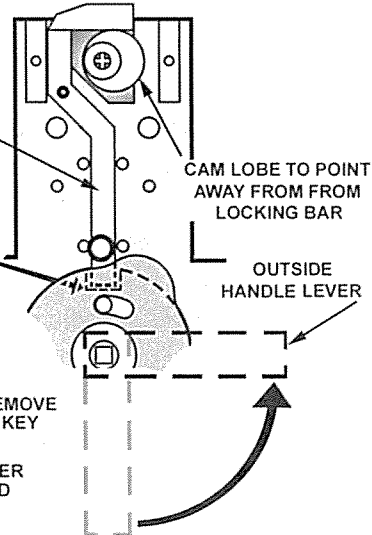

FIGURE 7

OPENING SIDE (WITH DOOR IN THE OPENED POSITION)
MARK CENTRE POINTS AT TOP & BOTTOM OF LOCKING BARS ON BOTH SIDES OF DOOR FRAME

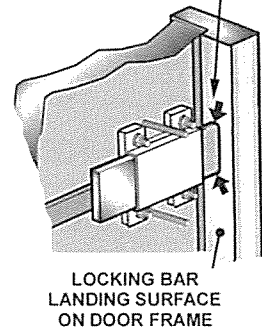

FIGURE 8

DRILL 12 mm DIAMETER HOLES AT TOP & BOTTOM MARKS OF LOCKING BAR ON BOTH SIDES OF FRAME

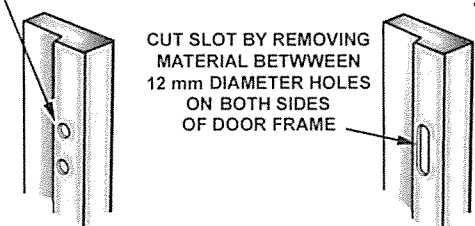

FIGURE 9

CUT SLOT BY REMOVING MATERIAL BETWEEN 12 mm DIAMETER HOLES ON BOTH SIDES OF DOOR FRAME

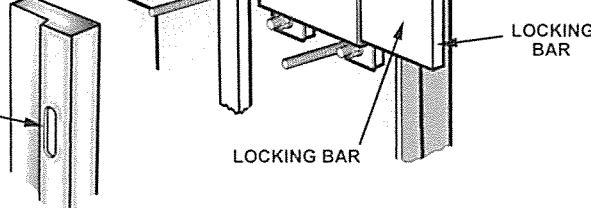

FIGURE 10