

**Bradley**  
AUSTRALIA

customised excellence

www.bradleyaustralia.com

## MODEL 252

**Option:**

**252-33 White Powdercoat**

### CONTEMPORARY SERIES TOWEL DISPENSER 252



#### PRODUCT FEATURES:

- Satin finish stainless steel
- Surface mounted
- Tumbler lock

Overall Dimensions  
280mm W x 210mm H x 100mm D

#### PRODUCT DATA:

##### CONSTRUCTION:

Unit fabricated of type 304 (18-8), 22 gauge stainless steel with exposed surfaces in architectural satin finish. Smooth corners, free of burrs and sharp edges. Tumbler lock. Cabinet hinged at the base to allow easy filling. Refill indicator slot on face of cabinet. Rolled edge on dispenser opening.

##### CAPACITY:

85mm folded (Slimline Model E2485) paper towels.

##### OPERATION:

Unit holds E2485 paper towels without use of special adaptors.

##### INSTALLATION:

Secure to wall with mounting screws (included) at holes provided.

##### GUIDE SPECIFICATION:

Surface mounted paper towel dispenser shall be fabricated of type 304 (18-8), 22 gauge stainless steel with exposed surfaces in architectural satin finish. Refill indicator on face of cabinet.

Tumbler lock to secure hinged front panel.

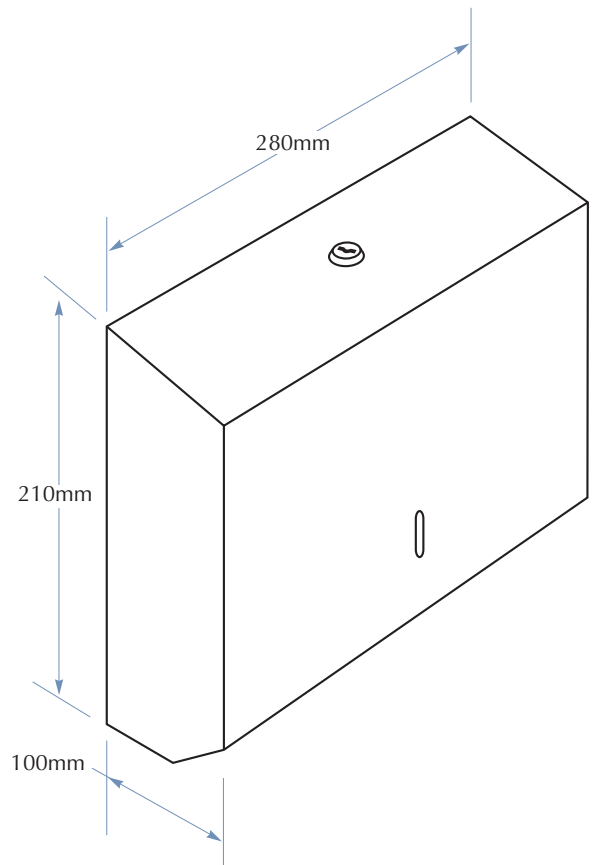

**TOLL FREE 1300 364 561**

The manufacturer reserves the right to make changes in design and material without formal notice and without incurring obligation.