

MORE THAN JUST QUALITY – AN EXPERIENCE™



FUTURA

## DUKE

### PASSAGE SET

Component: 1 Pair Lever Set &  
1x 1131 Heavy Duty Latch

#### Description:

- 15-Year Warranty: Futura Door Furniture is covered for 15 years internally and 10 years externally. If defective, Zanda will replace it for free.
- Ergonomic design for user comfort
- Modern European design
- Ideal for elderly
- Backsets are 60mm. Specify if otherwise.
- Suit domestic and light commercial application
- Suits 25mm hole size

#### Available Set:

- Lever Set
- Passage Set
- Separate Privacy Set
- Integrated Privacy Set
- Dummy Set
- Entrance Set

#### Available Finish:

- Brushed Nickel
- Graphite Nickel
- Matt Black
- Satin Brass
- White

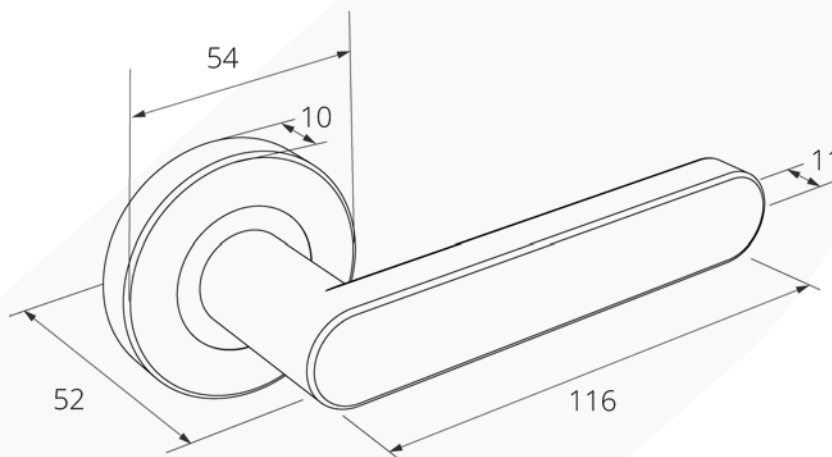

*Note: Measurements are in mm*

1 300 926 321 

sales@zanda.com.au 

www.zanda.com.au 

# FUTURA RAPIDFIT REMOVED PASSAGE SETS

Print: Actual size on A4 paper

Product Code: 10011 | 10021 | 10071  
10081 | 10091 | 7314 | 7033 | 7036 | 7107 | 10001 | 10051

### RapidFIT REMOVED

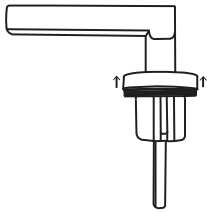

1. Unscrew the rose covers.

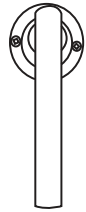

2. Remove the screw with the red screw head.



3. Remove the rapidFIT boss from the handle.

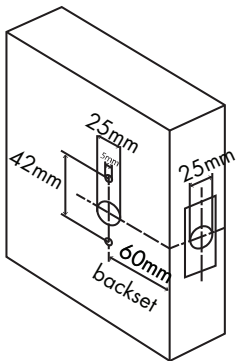

4. Measure the thickness and mark the centre at the desired height for the latch.
5. Drill a 25mm(1") diameter hole through the door edge to a depth of at least 90mm. Ensure this hole is square to the door.
6. Mark the face of the door each side for drilling a 25mm diameter spindle hole. The centre of the spindle hole will need to be 60mm from the door edge [backset]. Mark 2 6mm screw holes at 21mm above and below the centre of the spindle hole. For clean cutouts, drill from both side, meeting in the middle of the door.

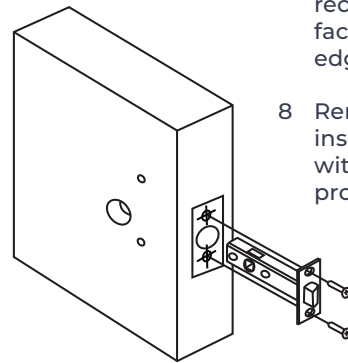

7. Insert the latch, scribe around the faceplate, remove, then chisel out the recess to enable the latch faceplate to sit flush the door edge.
8. Remove any loose saw dust, insert the latch and secure it with the wood screws provided.

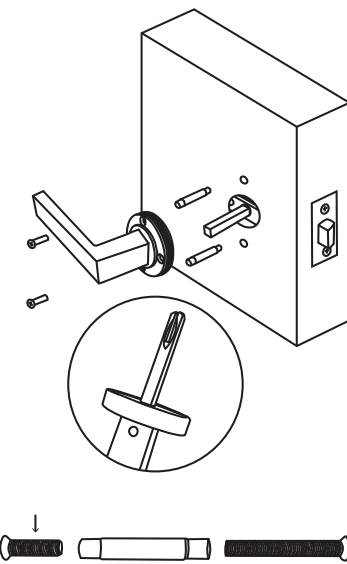
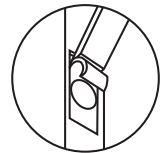

9. Unscrew the rose covers from the levers and unscrew the bolts from the threaded sleeves.
10. Insert the spindle into the latch so an even amount protrudes on each side of the door. Ensure the grooved side of the spindle will align with the grub screws on the handles.
11. Insert the threaded sleeves into the oval holes in the back of the rose at two vertical positions. Screw the short bolts from the top of the rose through into the threaded sleeves.
12. Slide the handle over the spindle and press against the door.

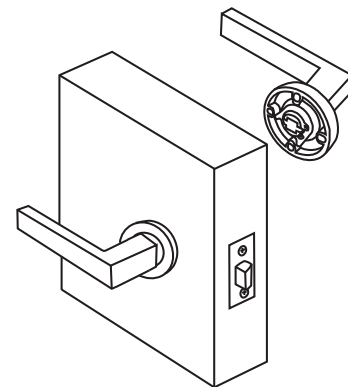

13. Insert the handle on the opposite side of the door over the spindle and tighten the long bolts through the rose into the threaded sleeves.
14. Screw the rose covers onto the handles and tighten the grub screws on the side of the levers onto the spindle for each side of the door.

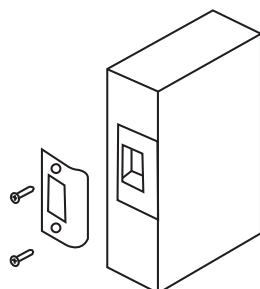

15. Close door against the frame and mark the latch position for fitting of the striker.
16. Router or chisel so the striker fits flush, allowing for the plastic dust-box behind the striker.
17. Secure the striker with the wood screws provided. Test the door and if necessary, adjust the striker and anti-rattle tab to take up any rattle.

# FUTURA RAPIDFIT PASSAGE SETS

Print: Actual size on A4 paper

Product Code: 10011 | 10021 | 10071  
10081 | 10091 | 7314 | 7033 | 7036 | 7107 | 10001 | 10051

- 1 Measure the thickness and mark the centre at the desired height for the latch.
- 2 Drill a 25mm(1") diameter hole through the door edge to a depth of atleast 90mm. Ensure this hole is square to the door.
- 3 Mark the face of the door each side for drilling a 48mm diameter spindle hole. The centre of the spindle hole will need to be 60mm from the door edge (backset). We recommend using a 48mm hole saw. For clean cutouts, drill from both side, meeting in the middle of the door.

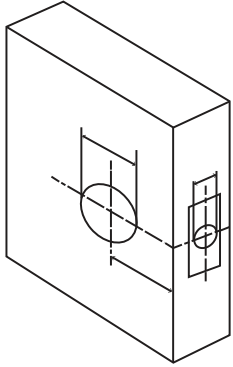

- 4 Insert the latch, scribe around the faceplate, remove, then chisel out the recess to enable the latch faceplate to sit flush the door edge.
- 5 Remove any loose saw dust, insert the latch and secure it with the wood screws provided.

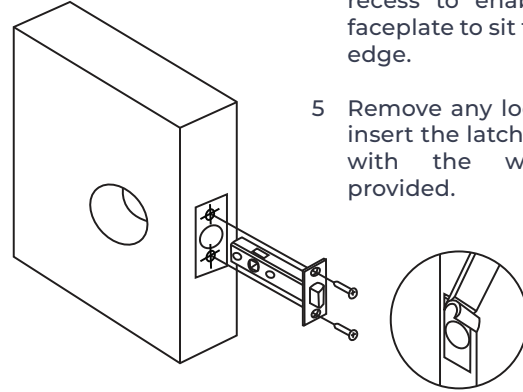

- 6 Insert handle 'A' in the 48mm hole with the spindle and rapidFIT attached and press against the door. Ensure the grooved side of the spindle is aligned with the grub-screws on the handle

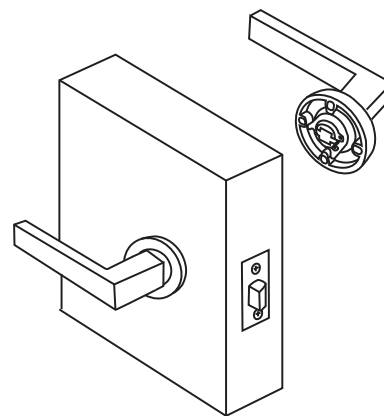
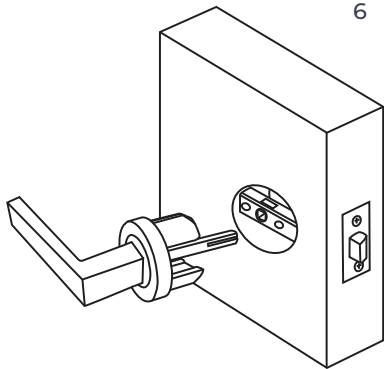

- 7 Insert handle 'B' over the spindle. Ensure the handles are straight before securing through the fixing screws.
- 8 Screw the rose cover onto the handle and tighten the grub screws on the side of the levers onto the spindle for each side of the door.

**Note:** The grub screws may need a re-tighten after a bedding period. We recommend medium strength thread-lock to be used.

- 9 Close door against the frame and mark the latch position for fitting of the striker.
- 10 Router or chisel so the striker fits flush, allowing for the plastic dustbox behind the striker.
- 11 Secure the striker with the wood screws provided. Test the door and if necessary, adjust the striker and anti-rattle tab to take up any rattle.

