

SKF ConCentra roller bearing units

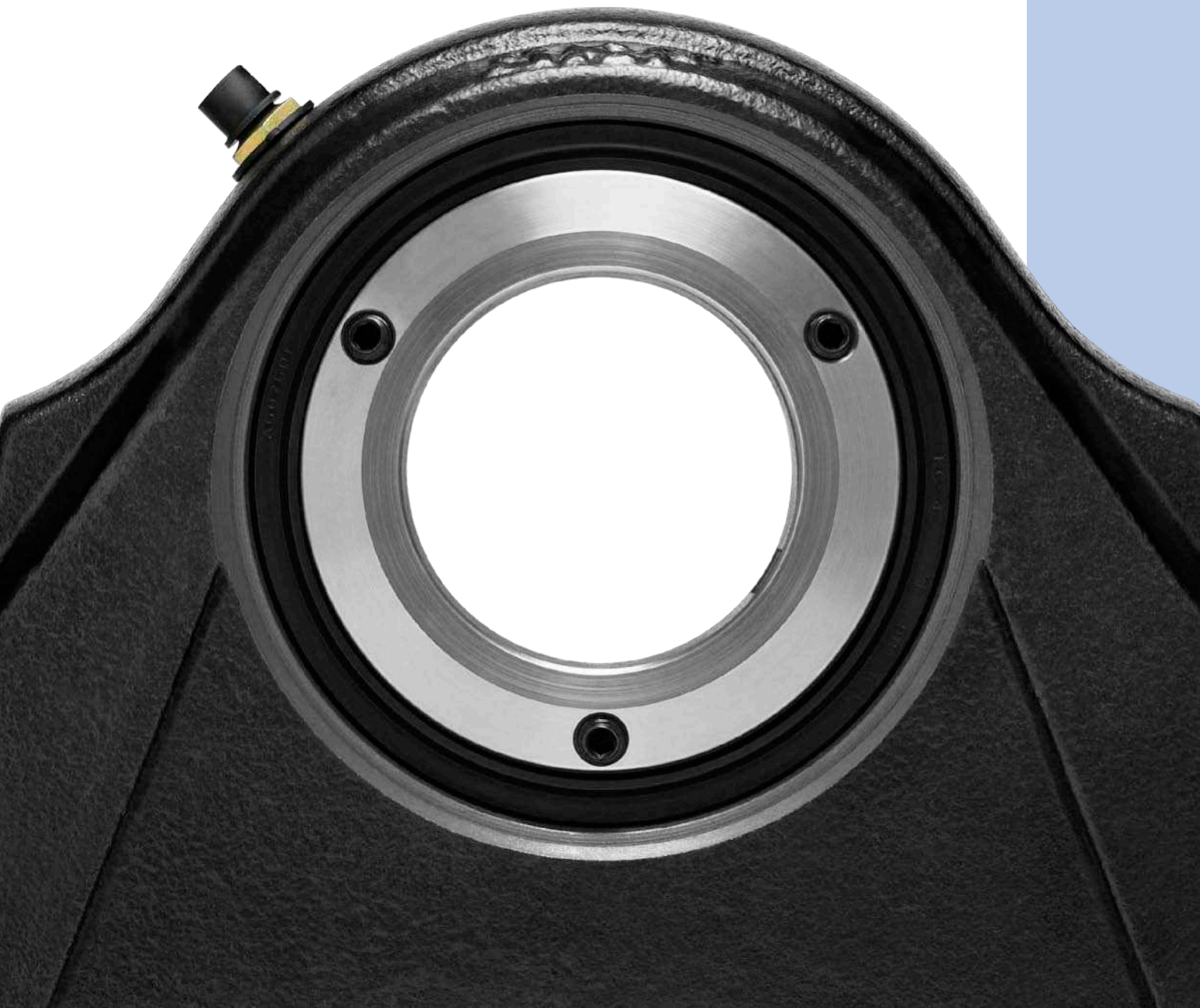



The SKF brand now stands for more than ever before, and means more to you as a valued customer.

While SKF maintains its leadership as the hallmark of quality bearings throughout the world, new dimensions in technical advances, product support and services have evolved SKF into a truly solutions-oriented supplier, creating greater value for customers.

These solutions encompass ways to bring greater productivity to customers, not only with breakthrough application-specific products, but also through leading-edge design simulation tools and consultancy services, plant asset efficiency maintenance programmes, and the industry's most advanced supply management techniques.

The SKF brand still stands for the very best in rolling bearings, but it now stands for much more.

SKF – the knowledge engineering company

Contents

A Product information

Ready to mount and operate	3
SKF ConCentra – a truly innovative concentric locking technology	4
SKF ConCentra roller bearing units	5
The housings	5
The bearing	6
The SKF ConCentra stepped sleeve	6
The seals	7
The end cover	7
The lubricants	7
Applications	8

B Recommendations

Selection of bearing unit variant	10
Selection of bearing unit size	12
SKF rating life	12
Loads	14
Design of bearing unit arrangements	16
Type of arrangement	16
Design of associated components	18
Lubrication and maintenance	20
Grease types	20
Relubrication	21
Grease life for the relubrication-free variant	23
Condition monitoring	24
Repainting the housing	24
Mounting and dismounting	25
Methods and tools	25
Mounting instructions	25
Dismounting instructions	30

C Product data

Product data – general	34
Boundary dimensions	34
Radial internal clearance	34
Misalignment	34
Speeds	34
Corrosion protection	34
Load carrying ability of the housings	35
Axial holding power	36
Designation system	37
Product tables	38
C.1 SKF ConCentra roller bearing units with a plummer block housing	38
C.2 SKF ConCentra roller bearing units with a flanged housing	40

D Additional information

Other SKF bearing units	42
SKF – the knowledge engineering company	46

Ready to mount and operate

SKF ConCentra roller bearing units are robust, ready-to-mount bearing units that are assembled, lubricated and sealed at the factory for maximum service life. When compared to sleeve-mounted bearing units in split housings, SKF ConCentra roller bearing units provide a number of advantages including:

- longer service life
- higher operational reliability
- quicker mounting
- minimal maintenance
- simplified replacement

These benefits, in addition to the wide assortment available, make SKF ConCentra roller bearing units suitable for a wide variety of applications. The assortment includes bearing units with a plummer block housing in four variants – including a relubrication-free variant – each optimized to accommodate different operating conditions. These are complemented by bearing units with a flanged housing that have an integral double-lip seal fitted on both sides. All bearing units are available as locating or non-locating units.

The simple installation, easy alignment and reliable locking technology of SKF ConCentra roller bearing units contribute to trouble-free operation.



SKF ConCentra – a truly innovative concentric locking technology

The locking concept of SKF ConCentra roller bearing units is based on the expansion and contraction of two mating surfaces: the bearing bore and the external surface of the stepped sleeve. Both surfaces have precision-engineered inclined serrations.

When the grub screws on the mounting collar are tightened, the mating surfaces are displaced axially. This forces the bearing inner ring to expand and the stepped sleeve to contract evenly, providing a true concentric

tight fit on the shaft and the appropriate internal clearance in the bearing. The wave spring, which facilitates dismounting, is pressed against the back-up ring on the opposite side of the bearing unit and preloaded during this time.

The near perfect 360° grip on the shaft virtually eliminates shaft damage and the possibility of fretting corrosion. The SKF ConCentra locking technology enables the bearing to operate reliably and achieve maximum bearing service life.

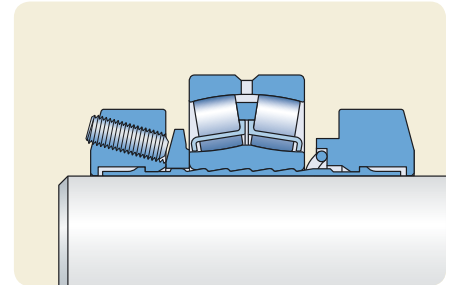
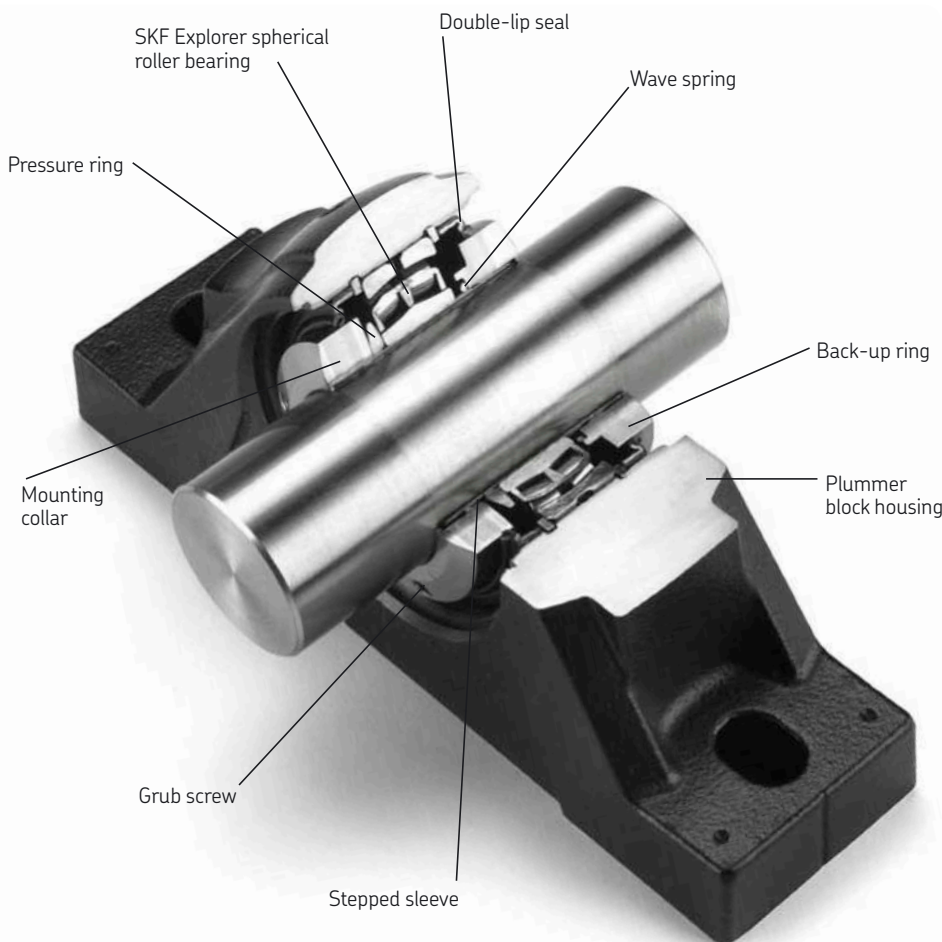

Prior to installation

There is clearance between the grub screws in the mounting collar and the pressure ring as well as between the bearing bore and the stepped sleeve.

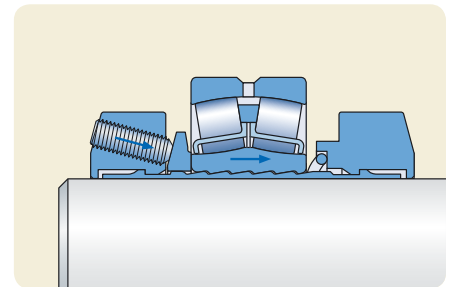

During installation

By tightening the grub screws in the mounting collar, the pressure ring forces the inner ring up the inclined serrations of the stepped sleeve.

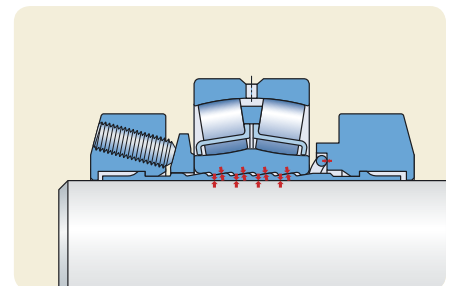

After installation

Once the grub screws have been tightened to the recommended torque, the correct internal clearance is reached and a true concentric tight fit is achieved on the shaft.

SKF ConCentra roller bearing units

The assortment of SKF ConCentra roller bearing units consists of both metric and inch bearing units that comprise:

- a plummer block or flanged housing
- an SKF Explorer spherical roller bearing
- an SKF ConCentra stepped sleeve
- an integral seal fitted on both sides
- an adequate grease fill

Metric units accommodate shaft diameters ranging from 35 to 100 mm; inch units range from 1 7/16 to 4 in.

Only metric bearing units are presented in this publication.

The housings

SKF ConCentra roller bearing units are available in two housing series:

- a non-split plummer block housing in the SYNT series
- a flanged housing in the FYNT series

Plummer block housings in the SYNT series have a stiff design that helps the housing to retain its form. These non-split, grey cast iron housings have the same excellent heat conducting properties and strength as comparably sized SKF split SNL plummer block housings.

Flanged housings in the FYNT series are also made of grey cast iron and are produced in two flange designs depending on the size:

- housings with a triangular shaped flange for shaft diameters ranging from 35 to 60 mm
- housings with a square shaped flange for shaft diameters ranging from 65 to 100 mm

Housings in the SYNT series have two holes cast into the base for attachment bolts. Housings in the FYNT series have either three or four drilled holes depending on the design. The area around the holes in both housing series is strengthened to minimize the risk of cracking caused by possible over-tightening of the attachment bolts. Centre lines and dimples cast into the housing base or flange facilitate mounting.

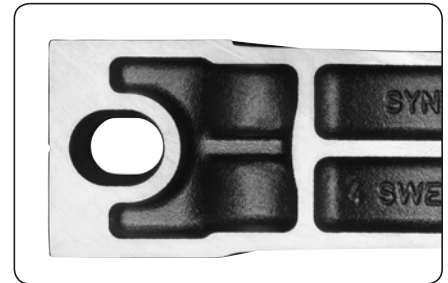

Stiff design

The ribs in the base of the plummer block housing help strengthen it and also enable good heat dissipation, while providing a solid flat surface for shims.

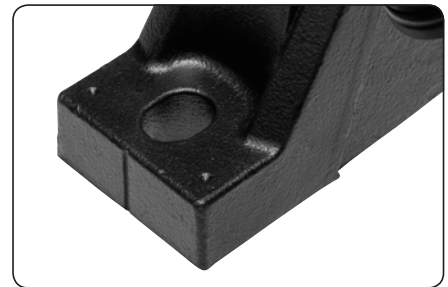

Markings in the base

To reduce alignment errors, centre lines cast into the housing base or flange indicate the position of the centre of the bearing. Appropriate positions for dowel pin holes are indicated by dimples.

SKF ConCentra roller bearing unit with a plummer block housing in the SYNT series



SKF ConCentra roller bearing unit with a triangular shaped flanged housing in the FYNT series



SKF ConCentra roller bearing unit with a square shaped flanged housing in the FYNT series



The bearing

The bearings used in SKF ConCentra roller bearing units are based on SKF Explorer E-design spherical roller bearings in the 222 series – the most popular spherical roller bearing series worldwide. These bearings are optimized for superior performance and endurance and contribute to long bearing service life and high operational reliability.

The bearings have the following features:

- a multi-tapered bore to accommodate the SKF ConCentra stepped sleeve
- self-guiding symmetrical rollers with an optimized roller profile
- a floating guide ring between the roller rows
- two lightweight, high-strength and wear-resistant steel cages

The bearings are self-aligning and can accommodate some misalignment of the shaft relative to the housing.

The SKF ConCentra stepped sleeve

The patented SKF ConCentra stepped sleeve, a masterpiece of locking technology, is the real innovation behind the SKF ConCentra bearing unit. The external surface of this low cross section sleeve has inclined serrations that match the profile of the bearing bore.

The stepped sleeve is supplied with a mounting collar, pressure ring, back-up ring and wave spring. The mounting collar is equipped with grub screws that are positioned at an angle, and not horizontal, to facilitate mounting and dismounting.

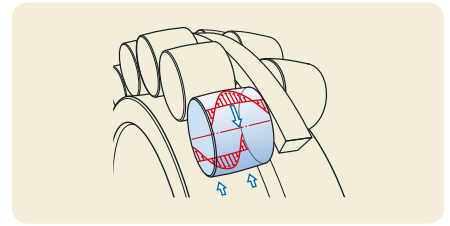

Low friction

The rollers, together with the floating guide ring, keep friction and heat generation to a minimum.

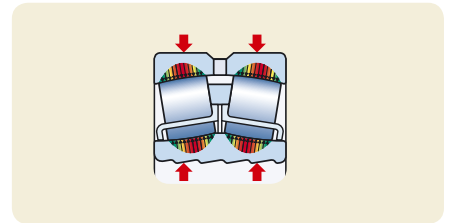

No edge stresses

The special roller profile prevents edge stresses from occurring.

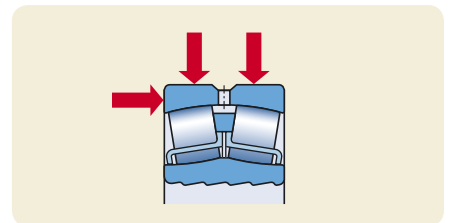

Very high load carrying capacity

The symmetrical rollers self-adjust, providing an even load distribution along the roller length. This provides very high load carrying capacity under all load combinations.

SKF Explorer E-design spherical roller bearing with inclined serrations on the bore



SKF ConCentra stepped sleeve



The seals

The seals of SKF ConCentra roller bearing units protect the bearing from the ingress of contaminants and retain the grease. The seals are integral to the bearing units, enabling them to remain compact. As sealing demands vary, depending on parameters such as the environment, circumferential speed and operating temperature, there are different seal types to choose from.

Bearing units with a plummer block housing are produced standard with:

- double-lip seals
- labyrinth seals
- heavy-duty radial shaft seals

Bearing units with a flanged housing are produced standard with double-lip seals only.

Double-lip seals

Double-lip seals consist of an acrylonitrile-butadiene rubber (NBR), vulcanized to a pressed steel shell. The steel shell enables the outside diameter of the seal to sit firmly in the housing bore, providing a static seal. The seal has an auxiliary lip to protect against coarse contaminants.

Labyrinth seals

As labyrinth seals do not generate friction, bearing units fitted with these seals are capable of relatively high speed operation. The labyrinth design is achieved by three sheet steel rings. Two rings are fixed to the mounting collar / back-up ring and rotate with the shaft to act as flingers. The third ring is secured in the housing bore.

Heavy-duty radial shaft seals

Heavy-duty radial shaft seals with a garter spring and an auxiliary lip provide superior protection against contaminants. These rugged and robust seals have a steel insert and an acrylonitrile-butadiene rubber (NBR) outside diameter. The primary seal lip is spring loaded and can maintain its sealing ability even after excessive wear. A secondary dust lip provides added protection against coarse contaminants.

The end cover

End covers are available for SKF ConCentra roller bearing units fitted at shaft ends. In addition to protecting the shaft ends of bearing arrangements, they also help prevent accidents.

End covers for bearing units in both the SYNT and FYNT series are made from polypropylene (PP), have good resistance to most chemicals and are suitable for operating temperatures up to 100 °C. These end covers can be snapped easily into the recess of the housing bore, on the mounting collar side.

The lubricants

SKF ConCentra roller bearing units are designed for grease lubrication and are greased at the factory. All bearing units, excluding the relubrication-free variant, are filled with premium mineral oil based grease with a lithium thickener. Relubrication-free bearing units are filled with semi-synthetic oil based grease with a lithium thickener. Both greases are characterized by:

- good lubricating properties, even under heavy loads and at low speeds
- maximum wear protection under severe operating conditions
- excellent ageing resistance
- excellent water resistance
- very good rust inhibiting properties

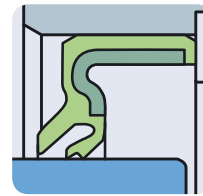

Double-lip seal

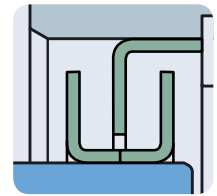

Labyrinth seal

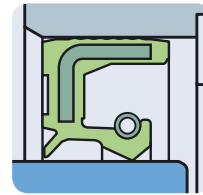

Heavy-duty radial shaft seal

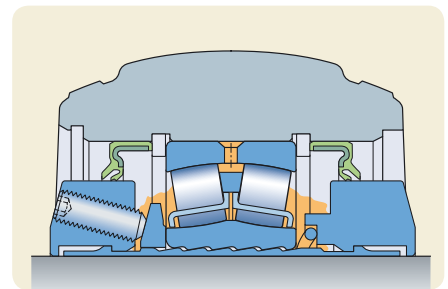

Lubricated
SKF ConCentra roller bearing units are greased at the factory.

End cover



Applications

SKF ConCentra roller bearing units are part of SKF's commitment to the "Total Shaft Solutions" programme that provides a wide assortment of innovative bearing products to the air handling, conveyor equipment, fluid machinery, agricultural and forestry industries.

SKF ConCentra roller bearing units, with their true concentric locking mechanism, are friction assemblies that provide optimum

performance in applications where there is a need for easy bearing unit replacement and minimal maintenance. There is no comparable bearing unit available on the market that can be mounted or dismounted as quickly and as accurately as the SKF ConCentra technology allows. Where bearing units with eccentric locking technology had been used before, SKF ConCentra roller bearing units provide superior performance.

Applications

- belt, bucket and chain conveyors
- mining and metallurgical equipment
- industrial air handling units
- fans and blowers
- commercial laundry equipment
- textile machines
- refining equipment
- large washing installations
- agricultural and forestry machinery
- food and beverage processing equipment
- mixers, crushers and vibrating screens
- light rail vehicles
- wastewater treatment equipment

Requirements

- ready-to-mount and ready-to-operate
- robust design
- strong and reliable
- effective sealing
- filled with premium grease
- insensitive to misalignment
- prepared for condition monitoring
- accommodate thermal elongation of the shaft

The solution

SKF ConCentra roller bearing units





Selection of bearing unit variant

With numerous applications and varying requirements, SKF ConCentra roller bearing units need to be versatile. There are four variants to choose from; each designed to accommodate four typical application conditions:

- general
- high-speed
- extreme environment
- relubrication-free

Each variant contains an SKF Explorer E-design spherical roller bearing in the 222 series and the SKF ConCentra stepped sleeve, but may differ from each other by the housing series, type of seal and type of grease.

When selecting the bearing unit variant (→ **table 1**), always consider the relubrication-free variant first as this is the most economical bearing unit. If this variant is not

suitable for the application, consider the general variant as the next option.

The housing series is typically determined by the design of the application. The type of grease is specific to the unit variant.

However, when selecting the type of seal, the most important points to consider are:

- operating temperature
- permissible circumferential speed at the seal lip (except for labyrinth seals)
- suitability to the environmental conditions

Details about the bearing unit variants are provided in **table 1**.



Table 1

SKF ConCentra roller bearing unit variants

Variant	General	High-speed	Extreme environment	Relubrication-free
Housing	 SYNT and FYNT series	 SYNT series only	 SYNT series only	 SYNT series only
Seal	 Double-lip	 Labyrinth	 Heavy-duty	 Double-lip
Permissible circumferential speed at the seal lip	13 m/s ¹⁾	–	6 m/s ¹⁾	13 m/s ^{1) 2)}
Permissible misalignment	1,5°	1,5°	1,5°	1,5°
Safe operating temperature range	35 to 100 °C ³⁾	35 to 110 °C ⁴⁾	35 to 100 °C ³⁾	–25 to +100 °C ²⁾
Lubricant	Mineral oil based grease with a lithium thickener and consistency grade NLGI 2			Semi-synthetic oil based grease with a lithium thickener and consistency grade NLGI 2–3
Conditions of use	Normal to heavy loads, 0,05 C < P ≤ 0,15 C			Light loads, P ≤ 0,05 C
Suitable environmental conditions	Normal to contaminated environments	Relatively clean to normal environments	Extremely contaminated environments	Relatively clean environments
Application examples	 Textile machines	 Industrial fans and blowers	 Belt conveyors	 Industrial air handling units
Designation suffix for variant	–	TS	TF	W
Designation label colour	Black	Blue	Red	Green
Designation label example				

¹⁾For limiting speeds of the bearing units, refer to the product tables.

²⁾Refer to **diagram 4** on **page 23**.

³⁾Imposed by the seal, which can withstand temperatures up to 120 °C for very brief periods.

⁴⁾Imposed by the grease.

Selection of bearing unit size

SKF rating life

The size of an SKF ConCentra roller bearing unit is selected initially on the basis of the loads within the application, as well as the load carrying capacity, reliability and expected service life of the bearing unit. The load carrying capacity is expressed by the basic dynamic and static load ratings. The basic dynamic load ratings are determined according to the methods described in ISO 281:2007; the basic static load ratings are in accordance with ISO 76:2006.

The simplest method for calculating roller bearing life is to use the ISO equation for basic rating life, which is

$$L_{10} = \left(\frac{C}{P} \right)^{10/3}$$

The life-extending improvements embodied in SKF Explorer spherical roller bearings can best be understood by using the SKF rating life equation in accordance with ISO 281:2007

$$L_{nm} = a_1 a_{SKF} \left(\frac{C}{P} \right)^{10/3}$$

or

$$L_{nmh} = a_1 a_{SKF} \frac{1\,000\,000}{60 n} \left(\frac{C}{P} \right)^{10/3}$$

where

- L_{10} = basic rating life (at 90% reliability) [millions of revolutions]
- L_{nm} = SKF rating life (at $100 - n^1$ reliability) [millions of revolutions]
- L_{nmh} = SKF rating life (at $100 - n^1$ reliability) [operating hours]
- a_1 = life adjustment factor for reliability (→ **table 1**)
- a_{SKF} = SKF life modification factor (→ **diagram 1**)
- C = basic dynamic load rating [kN] (→ *product tables*)
- P = equivalent dynamic bearing load [kN] (→ *Equivalent dynamic bearing load, page 14*)
- n = rotational speed [r/min]

¹⁾ Here, the factor n represents the failure probability.

Table 1

Life adjustment factor a_1 for SKF rating life equation

Reliability	Failure probability n	SKF rating life L_{nm}	Life adjustment factor a_1
%	%	–	–
90	10	L_{10m}	1
95	5	L_{5m}	0,62
96	4	L_{4m}	0,53
97	3	L_{3m}	0,44
98	2	L_{2m}	0,33
99	1	L_{1m}	0,21

Table 2

Guideline values for the factor η_c for different levels of contamination

Environmental conditions

Factor η_c ¹⁾
for shaft diameter

$d_a < 75$ mm

$d_a \geq 75$ mm

High cleanliness

Conditions typical for relubrication-free SKF ConCentra roller bearing units, with double-lip seals (designation suffix W)

0,8 ... 0,6

0,9 ... 0,8

Normal cleanliness

Conditions typical for SKF ConCentra roller bearing units with double-lip seals (no designation suffix)

0,8 ... 0,6

0,9 ... 0,8

Conditions typical for SKF ConCentra roller bearing units with labyrinth seals (designation suffix TS)

0,6 ... 0,5

0,8 ... 0,6

Contaminated environments

Conditions typical for SKF ConCentra roller bearing units with heavy-duty radial shaft seals (designation suffix TF)

0,6 ... 0,5

0,8 ... 0,6

¹⁾ As smaller bearings are affected more by contamination than larger bearings, the lower value of the factor η_c in each range applies to the smallest shaft diameter referenced in that column.

Reliability – the life adjustment factor a_1

Values for the life adjustment factor a_1 for reliability are listed in **table 1**.

SKF life modification factor a_{SKF}

The factor a_{SKF} represents a very complex relationship between various influencing factors including the fatigue load limit, contamination and lubrication. Contamination and fatigue load limit conditions are expressed by the contamination-load ratio η_c (P_u/P) while lubrication conditions are expressed by the viscosity ratio κ .

Values for a_{SKF} can be obtained from **diagram 1** as a function of:

- the fatigue load limit P_u (→ *product tables*)
- the equivalent dynamic bearing load P (→ **page 14**)
- the factor for contamination level η_c (→ **table 2**)
- the viscosity ratio κ (→ **page 14**)

The values include a safety factor commonly used in fatigue life considerations.

Contamination – the factor η_c for contamination level

The factor η_c considers the degree of contamination of the grease in the bearing life calculation. It is difficult to allocate precise values to the factor for each application since the influence of contamination on bearing fatigue depends on a number of parameters. However, some guideline values are provided in **table 2**. In general, the factor η_c can be improved in highly contaminated environments by regular relubrication.

Diagram 1

Factor a_{SKF} for bearings in SKF ConCentra roller bearing units

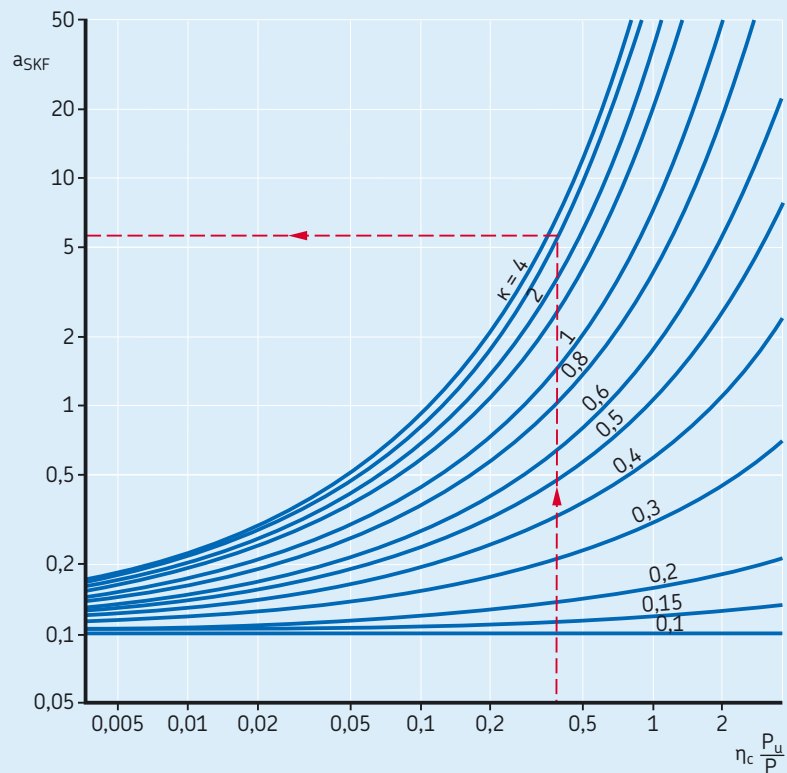
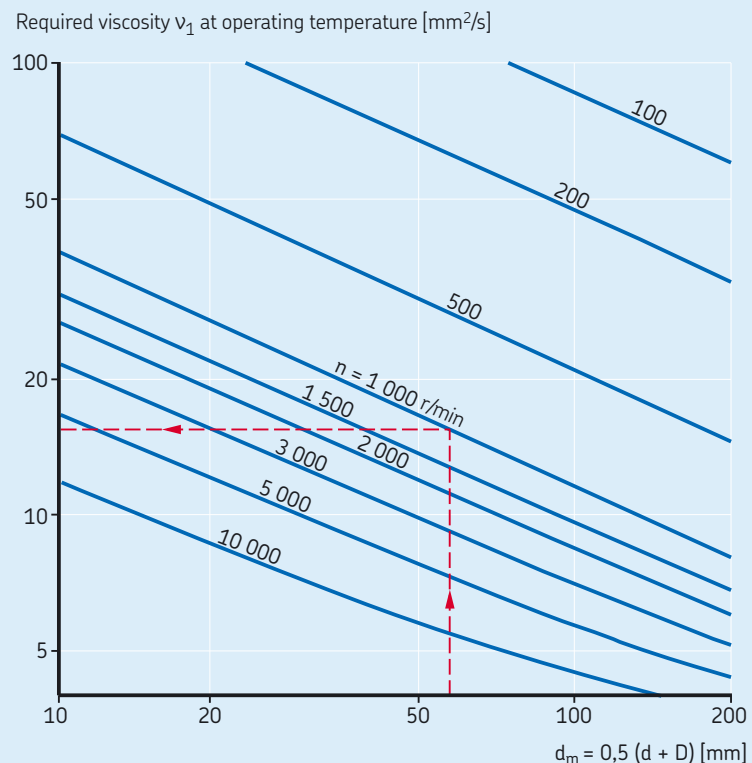

Diagram 2

Estimation of the required minimum kinematic viscosity ν_1 at operating temperature



Lubrication conditions – the viscosity ratio κ

In order to form an adequate lubricant film between the rolling contact surfaces, the base oil in the grease must retain a certain minimum viscosity at the operating temperature. The condition of the lubricant is described by the viscosity ratio κ as the ratio of the actual viscosity ν to the rated viscosity ν_1 for adequate lubrication, both values being considered at normal operating temperature

$$\kappa = \nu/\nu_1$$

where

κ = viscosity ratio

ν = actual kinematic viscosity at operating temperature [mm²/s]

ν_1 = required minimum kinematic viscosity [mm²/s]

The required minimum kinematic viscosity ν_1 at operating temperature can be determined from **diagram 2** on **page 13** as a function of the bearing mean diameter d_m (→ **table 3**) and rotational speed n . The actual kinematic viscosity ν at the expected operating temperature can be determined from **diagram 3**, using the base oil viscosity of the grease in SKF ConCentra roller bearing units, which is 200 mm²/s at 40 °C.

Additional information and calculation tools are available in the *SKF General Catalogue* or the *SKF Interactive Engineering Catalogue* available online at www.skf.com.

Loads

Minimum load

To provide satisfactory operation, the spherical roller bearing in an SKF ConCentra roller bearing unit must always be subjected to a given minimum load, particularly if the bearing unit is to operate at high speeds or is subjected to high accelerations or rapid changes in the direction of load. Under these conditions, the inertial forces of the rollers and cages, and the friction in the grease, can have a detrimental influence on the rolling conditions in the bearing arrangement and may cause damaging sliding movements to occur between the rollers and raceways.

The requisite minimum load to be applied can be estimated using

Conversion to the actual kinematic viscosity ν at operating temperature

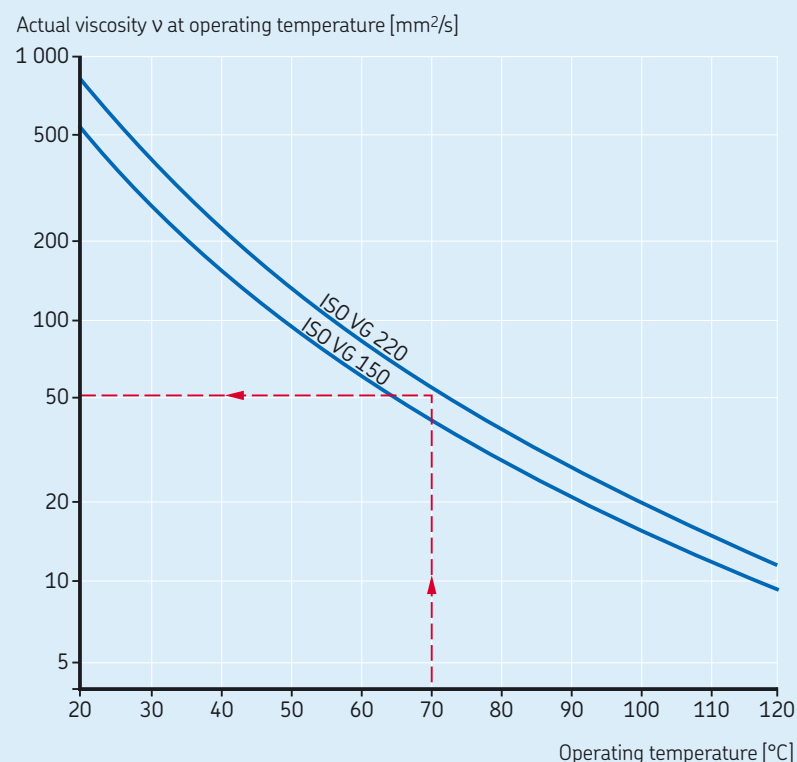

$$P_m = 0,01 C_0$$

where

P_m = equivalent minimum load [kN]

C_0 = basic static load rating [kN]

(→ *product tables*)

When starting up at low temperatures, even higher minimum loads than $P_m = 0,01 C_0$ may be required. The weight of the components supported by the bearing, together with external forces, generally exceeds the requisite minimum load. If this is not the case, the bearing must be subjected to an additional radial load such as by increasing belt tension or idling torque.

Equivalent dynamic bearing load

The equivalent dynamic bearing load for the bearings in SKF ConCentra roller bearing units can be obtained from

$$P = F_r + Y_1 F_a \quad \text{when } F_a/F_r \leq e$$

$$P = 0,67 F_r + Y_2 F_a \quad \text{when } F_a/F_r > e$$

where

P = equivalent dynamic bearing load [kN]

F_r = radial component of the bearing load [kN]

F_a = axial component of the bearing load [kN]

Y_1, Y_2 = axial load calculation factors for the bearing (→ **table 4**)

e = limiting value for F_a/F_r (→ **table 4**)

Equivalent static bearing load

The equivalent static bearing load for the bearings in SKF ConCentra roller bearing units can be obtained from

$$P_0 = F_r + Y_0 F_a$$

where

P_0 = equivalent static bearing load [kN]

F_r = radial component of the bearing load [kN]

F_a = axial component of the bearing load [kN]

Y_0 = axial load calculation factor for the bearing (→ **table 4**)

Calculation example

An SKF ConCentra roller bearing unit with a plummer block housing is required for a chain conveyor application. The following application information is known:

- required SKF rating life $L_{10mh} = 100\,000$ hours
- equivalent dynamic bearing load $P = 12$ kN
- rotational speed $n = 1\,000$ r/min
- shaft diameter $d_a = 40$ mm
- environmental conditions: contaminated
- expected operating temperature: 70 °C

Based on the shaft diameter provided, plummer block housing requirement and the level of contamination, the bearing unit SYNT 40 FTF (or SYNT 40 LTF) is selected. From the product table:

- basic dynamic load rating $C = 96,5$ kN
- fatigue load limit $P_u = 9,8$ kN

For $d_a = 40$ mm and a factor $\eta_c \approx 0,55$ (→ **table 2, page 12**),

$$\eta_c (P_u/P) = 0,55 (9,8/12) = 0,45$$

For $d_m = 60$ mm and $n = 1\,000$ r/min, $v_1 \approx 16$ mm²/s (→ **diagram 2, page 13**).

With the base oil viscosity of the grease being 200 mm²/s at 40 °C , $v \approx 51$ mm²/s (→ **diagram 3**). Therefore,

$$\kappa = v/v_1 = 51/16 = 3,2$$

Using **diagram 1** on **page 13**, for $\eta_c (P_u/P) = 0,45$ and $\kappa = 3,2$, $a_{SKF} \approx 6$.

Using the SKF rating life equation

$$L_{nmh} = a_1 a_{SKF} \frac{1\,000\,000}{60 n} \left(\frac{C}{P} \right)^{10/3}$$

with $a_1 = 1$

$$L_{10mh} = 1 \times 6 \times \frac{1\,000\,000}{60 \times 1\,000} \times \left(\frac{96,5}{12} \right)^{10/3}$$

$$\approx 104\,000 \text{ hours}$$

The bearing unit SYNT 40 FTF (or SYNT 40 LTF) meets the SKF rating life requirement and is therefore suitable for the application.

Table 3

Mean diameter of bearings in SKF ConCentra roller bearing units

Bearing unit Basic designation	Bearing Mean diameter d_m
–	mm
SYNT 35	53,5
SYNT 40	60
SYNT 45	65
SYNT 50	70
SYNT 55	77,5
SYNT 60	85
SYNT 65	92,5
SYNT 70	97,5
SYNT 75	102,5
SYNT 80	110
SYNT 90	125
SYNT 100	140

Table 4

Calculation factors for calculating the equivalent bearing load

Bearing unit Basic designation		Calculation factors			
		e	Y_1	Y_2	Y_0
SYNT 35	FYNT 35	0,31	2,2	3,3	2,2
SYNT 40	FYNT 40	0,28	2,4	3,6	2,5
SYNT 45	FYNT 45	0,26	2,6	3,9	2,5
SYNT 50	FYNT 50	0,24	2,8	4,2	2,8
SYNT 55	FYNT 55	0,24	2,8	4,2	2,8
SYNT 60	FYNT 60	0,24	2,8	4,2	2,8
SYNT 65	FYNT 65	0,24	2,8	4,2	2,8
SYNT 70	FYNT 70	0,22	3,0	4,6	2,8
SYNT 75	FYNT 75	0,22	3,0	4,6	2,8
SYNT 80	FYNT 80	0,22	3,0	4,6	2,8
SYNT 90	FYNT 90	0,24	2,8	4,2	2,8
SYNT 100	FYNT 100	0,24	2,8	4,2	2,8

Design of bearing unit arrangements

Type of arrangement

Locating and non-locating bearing units

Generally, two bearings are required to support a rotating machine component with the typical arrangement comprising one locating and one non-locating bearing unit (→ **fig. 1**). Due to these requirements, SKF ConCentra roller bearing units are available as locating and non-locating bearing units.

Locating bearing units, which are typically positioned at the drive end, support the shaft radially and locate it axially in both directions.

Non-locating bearing units provide radial support and accommodate axial displacement of the shaft relative to the housing, as a result of thermal elongation. The permissible axial displacement for these bearing units is 2,5 mm from the central position of the unit (5 mm maximum).

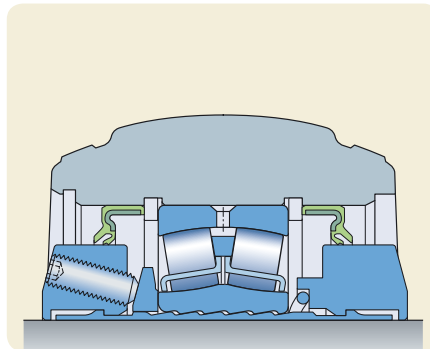

Locating bearing unit

Locating bearing units locate the shaft axially in both directions.

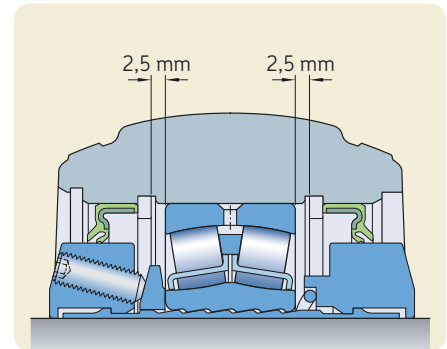

Non-locating bearing unit

Non-locating bearing units have sufficient axial space to accommodate up to 2,5 mm of movement in either direction.

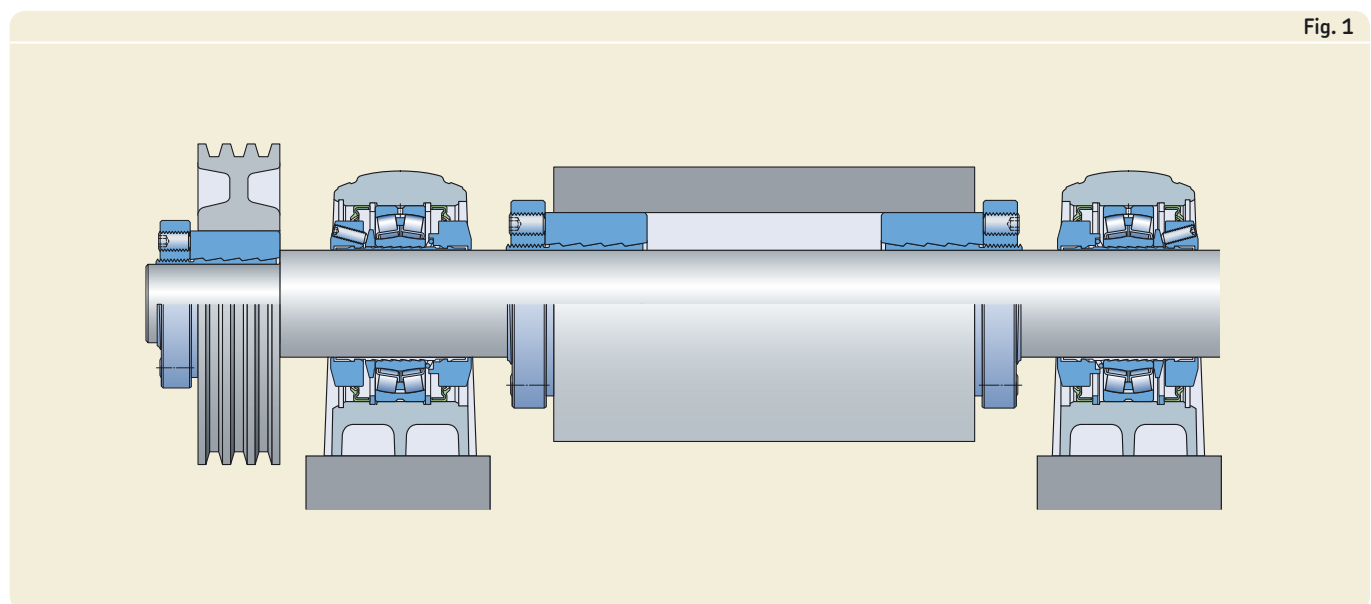

Fig. 1

Bearing unit arrangement at shaft ends

When SKF ConCentra roller bearing units are mounted at the end of a shaft, the outboard side should be fitted with an end cover. The designation of the appropriate end cover is provided in **table 1**. The permissible length of the shaft end and the allowable protrusion dimensions of the end cover are also provided.

Table 1

End covers for SKF ConCentra roller bearing units at shaft ends

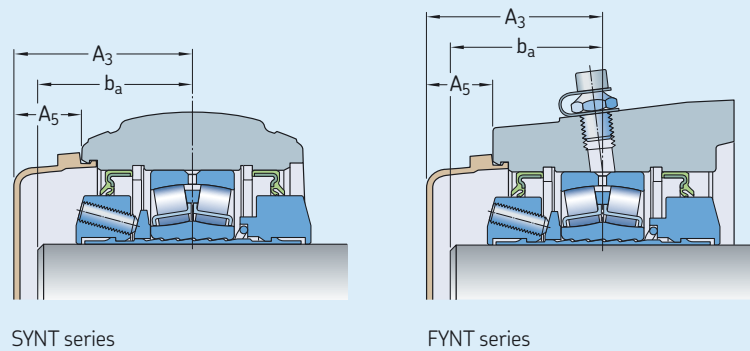

Bearing unit Basic designation	Dimensions b_a		A_3	A_5	End cover Designation
	min	max			
–	mm		–	–	–
SYNT 35	34	43	50	22	ECY 207
SYNT 40	34	43	51	23,5	ECY 208
SYNT 45	34	43	52	23	ECY 209
SYNT 50	34	55	62	29,5	ECY 210
SYNT 55	34	55	66	34	ECY 211
SYNT 60	38	65	73	35,5	ECY 212
SYNT 65	38	65	73	35,5	ECY 213
SYNT 70	38	70	80	38,5	ECY 214
SYNT 75	38	70	80	38,5	ECY 215
FYNT 35	34	43	50	22	ECY 207
FYNT 40	34	43	51	23,5	ECY 208
FYNT 45	34	43	52	23	ECY 209
FYNT 50	34	55	62	29,5	ECY 210
FYNT 55	34	55	66	34	ECY 211
FYNT 60	38	65	73	35,5	ECY 212
FYNT 65	38	65	73	35,5	ECY 213
FYNT 70	38	70	80	38,5	ECY 214
FYNT 75	38	70	80	38,5	ECY 215

Design of associated components

Shaft requirements

SKF ConCentra roller bearing units can be used with commercial grade shafts. SKF recommends using shaft seats to dimensional tolerance class h9 and cylindricity tolerance IT5/2, in accordance with ISO 1101:2004.

The surface roughness R_a of the sleeve seat, in accordance with ISO 4288:1996, should not exceed $3,2 \mu\text{m}$. A small lead-in chamfer on the end of the shaft will facilitate mounting.

Support surface requirements

To maximize the service life of an SKF ConCentra roller bearing unit, SKF recommends using a support (mounting) surface with a surface roughness $R_a \leq 12,5 \mu\text{m}$ and flatness tolerance that meets IT7 specifications.

Attachment to support surfaces

SKF ConCentra roller bearing units in the SYNT series have two slotted holes cast into the base of the housing. Bearing units in the FYNT series have three and four drilled holes in the triangular and square shaped flange designs respectively.

To attach the bearing units to their support (mounting) surfaces, SKF recommends using fasteners such as hexagon headed bolts in accordance with ISO 4014:1999. For radial loads that act in the direction of the support surface, strength class 8.8 bolts can be used. If the loads are particularly heavy or act in other directions, strength class 10.9 bolts are preferred.

In addition to the attachment bolts, SKF recommends using dowel pins to pin bearing units in the SYNT series to their support surfaces under the following conditions (→ **table 2, page 35**):

- if the direction of the load lies between 55 and 120°
- if the load acts parallel to the support surface and exceeds 5% of the breaking load P_{180°

Appropriate positions for these dowel pins are indicated by dimples cast into the housing feet. Details about the position and size of the dowel pin holes are listed in **table 2**.

Bearing units in the FYNT series have a machined recess as standard; this can be used to centre the bearing unit on a shoulder on a machine wall. The shoulder can be provided by machining the wall accordingly (→ **fig. 2a**) or by attaching an appropriate guide ring to the wall (→ **fig. 2b**). The dimensions of the recess are provided in the product table. Dowel pins can also be used where necessary. Appropriate positions for these dowel pins are indicated by dimples cast into the housing flange.

Fig. 2

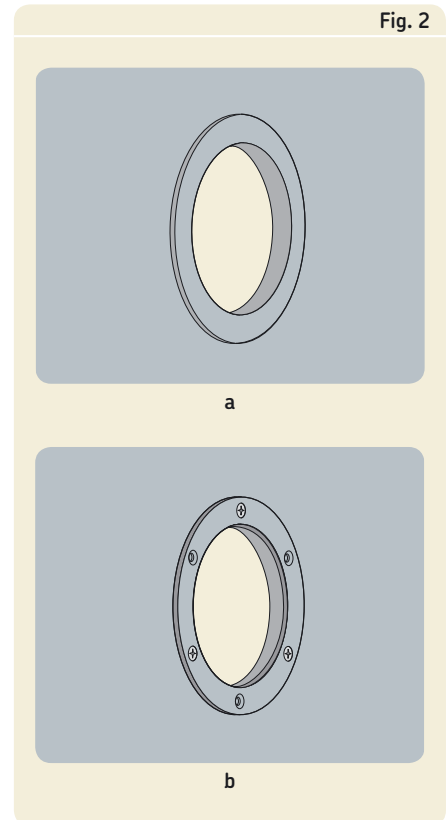
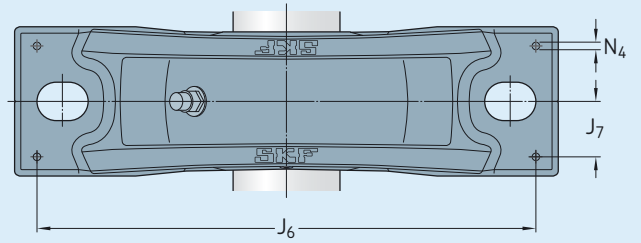

Table 2

Position and size of dowel pin holes for SKF ConCentra roller bearing units in the SYNT series



Bearing unit Basic designation	Dimensions		
	J ₆	J ₇	N ₄ max
— mm			
SYNT 35	135	23	6
SYNT 40	135	23	6
SYNT 45	135	23	6
SYNT 50	170	27	8
SYNT 55	172	27	8
SYNT 60	190	32	8
SYNT 65	190	32	8
SYNT 70	218	35	8
SYNT 75	218	35	8
SYNT 80	320	35	8
SYNT 90	355	40	8
SYNT 100	385	45	8

B

Lubrication and maintenance

Grease types

SKF ConCentra roller bearing units, excluding the relubrication-free variant, are filled with premium grease that contains EP additives. The grease is mineral oil based with a lithium thickener and consistency of 2 on the NLGI scale.

Relubrication-free SKF ConCentra roller bearing units are filled with a premium long life grease. This grease has a semi-synthetic base oil, lithium thickener and consistency of 2–3 on the NLGI scale. The technical specifications of both greases are listed in **table 1**.

The initial grease fill at the factory fills the bearing completely. The free space in the housing is partially filled with grease as follows:

- 60 to 80% for the relubrication-free variant
- 30 to 50% for all other variants

Temperature range – the SKF traffic light concept

The temperature range of grease depends on the base oil and thickener and to a lesser extent, the additives. The range is characterized by four temperature limits:

- low temperature limit (LTL)
- low temperature performance limit (LTPL)
- high temperature performance limit (HTPL)
- high temperature limit (HTL)

SKF illustrates this schematically in the form of a “double traffic light” (→ **fig. 1**). The green zone, between the LTPL and the HTPL, represents the temperature range wherein the grease functions most reliably.

For additional information about the SKF traffic light concept, refer to the *SKF General Catalogue* or the *SKF Interactive Engineering Catalogue* available online at www.skf.com.

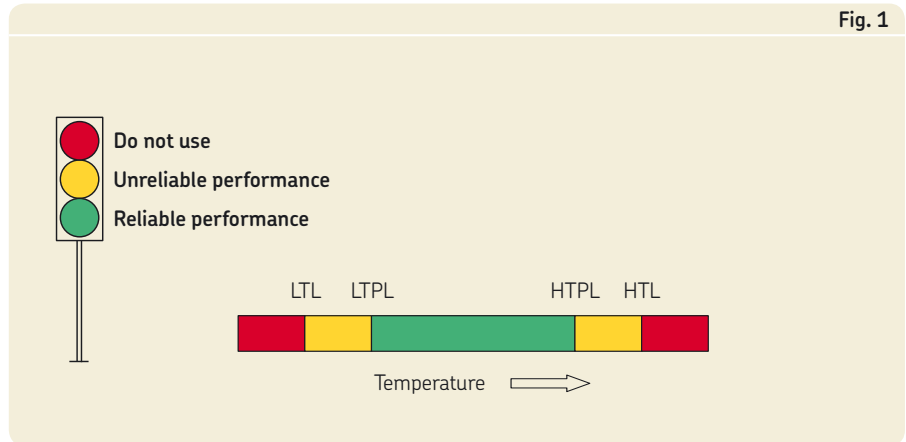

Table 1

Technical specifications of the grease in SKF ConCentra roller bearing units										
Properties	Grease specification All bearing units, excluding the relubrication-free variant	Relubrication-free variant								
Thickener	Lithium soap	Lithium soap								
Base oil type	Mineral	Semi-synthetic								
NLGI consistency class	2	2–3								
Temperature range [°C]	<table border="1" style="width: 100%; text-align: center;"> <tr> <td style="width: 25%;">-20</td> <td style="width: 25%;">+35</td> <td style="width: 25%;">+110</td> <td style="width: 25%;">+170</td> </tr> </table>	-20	+35	+110	+170	<table border="1" style="width: 100%; text-align: center;"> <tr> <td style="width: 25%;">-40</td> <td style="width: 25%;">-25</td> <td style="width: 25%;">+130</td> <td style="width: 25%;">+170</td> </tr> </table>	-40	-25	+130	+170
-20	+35	+110	+170							
-40	-25	+130	+170							
[°F]	<table border="1" style="width: 100%; text-align: center;"> <tr> <td style="width: 25%;">-5</td> <td style="width: 25%;">+95</td> <td style="width: 25%;">+230</td> <td style="width: 25%;">+340</td> </tr> </table>	-5	+95	+230	+340	<table border="1" style="width: 100%; text-align: center;"> <tr> <td style="width: 25%;">-40</td> <td style="width: 25%;">-15</td> <td style="width: 25%;">+265</td> <td style="width: 25%;">+340</td> </tr> </table>	-40	-15	+265	+340
-5	+95	+230	+340							
-40	-15	+265	+340							
Kinematic viscosity [mm ² /s] at 40 °C	200	41,9								
at 100 °C	13	7,5								

Relubrication

The bearings in SKF ConCentra roller bearing units are typically relubricated in order to realize maximum service life. All bearing units have a lubrication hole with a 1/8-27 NPSF thread. They are provided standard with a grease fitting AH 1/8-27 PTF, except for the relubrication-free variants, which have the lubrication hole plugged.

Relubrication intervals

The relubrication intervals t_r for SKF ConCentra roller bearing units (excluding the relubrication-free variant) can be obtained from **diagrams 1 to 3** as a function of:

- the operating temperature [°C]
- the rotational speed n [r/min]
- the bearing mean diameter d_m [mm] (→ **table 3, page 15**)
- the bearing factor b_f
 - $b_f = 2$ for $F_a/F_r \leq e$
 - $b_f = 6$ for $F_a/F_r > e$
- the load ratio
 - $P \leq 0,05 C$ (→ **diagram 1**)
 - $P = 0,1 C$ (→ **diagram 2**)
 - $P = 0,15 C$ (→ **diagram 3 on page 22**)

The intervals represent the grease life L_{11} , which relates to the time period at the end of which 99% of the bearing units are still reliably lubricated. The intervals are estimated values, applicable for bearing units mounted on horizontal shafts in a relatively clean environment.

When operating conditions differ, the relubrication intervals should be adjusted as follows:

- For a vertical shaft, the interval should be halved.
- For outer ring rotation or rotating load, the interval should be halved.
- For contaminated environments, the following reduction factors should be used:
 - 0,5 for moderate contamination
 - 0,3 for severe contamination
 - 0,1 for very severe contamination

Diagram 1

Relubrication interval t_r for SKF ConCentra roller bearing units, for $P \leq 0,05 C$

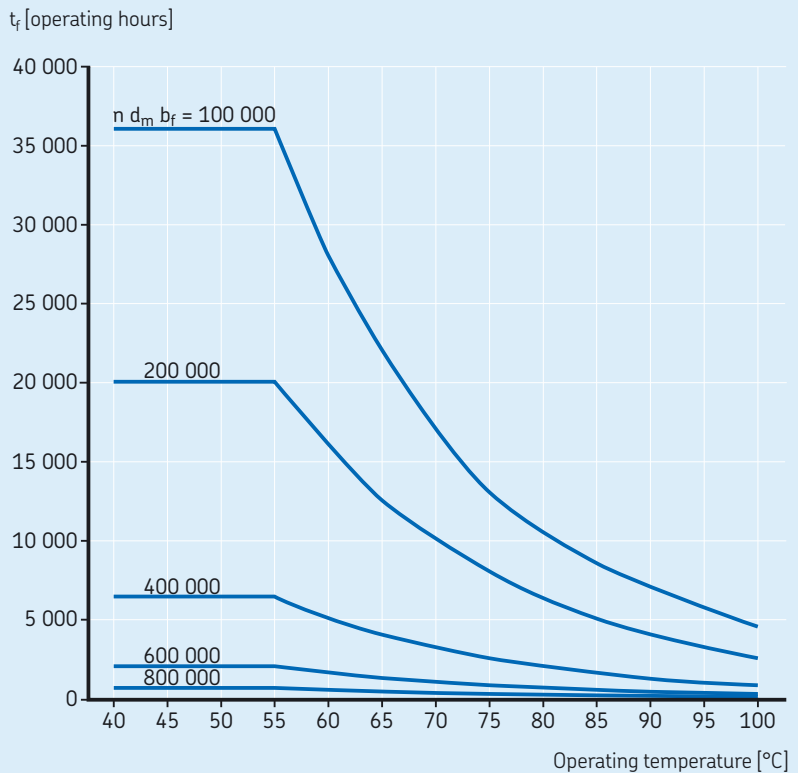
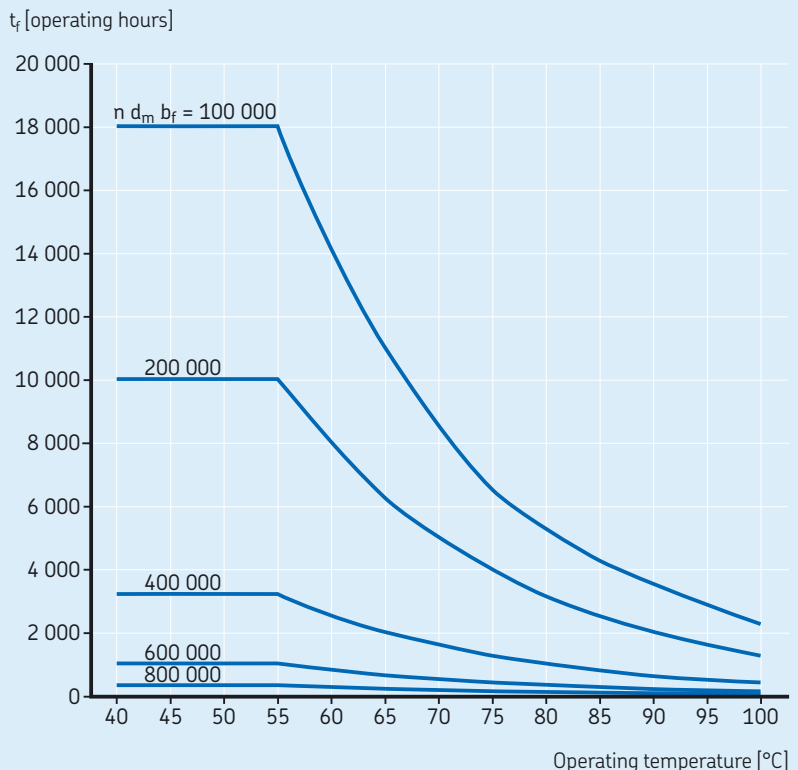

Diagram 2

Relubrication interval t_r for SKF ConCentra roller bearing units, for $P = 0,1 C$



Relubrication procedure

Before relubricating, the grease fitting and area surrounding the bearing unit should be cleaned; high-pressure cleaning equipment should be avoided.

During relubrication, grease should be introduced via the grease fitting (→ **fig. 2**) while the shaft is rotating slowly. Excessive pressure and over-greasing should be avoided, otherwise the seals may be damaged.

Relubrication quantity

The appropriate quantity of grease for relubrication of SKF ConCentra roller bearing units is provided in **table 2**.

Greases for relubrication

To relubricate SKF ConCentra roller bearing units, SKF recommends using SKF LGEP 2 grease, which is fully compatible with the original grease introduced at the factory. Other compatible greases such as SKF's multipurpose LGMT 2 and LGMT 3 greases can also be used.

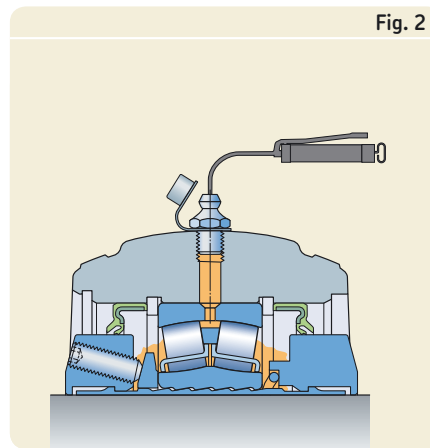

Diagram 3

Relubrication interval t_r for SKF ConCentra roller bearing units, for $P = 0,15 C$

t_r [operating hours]

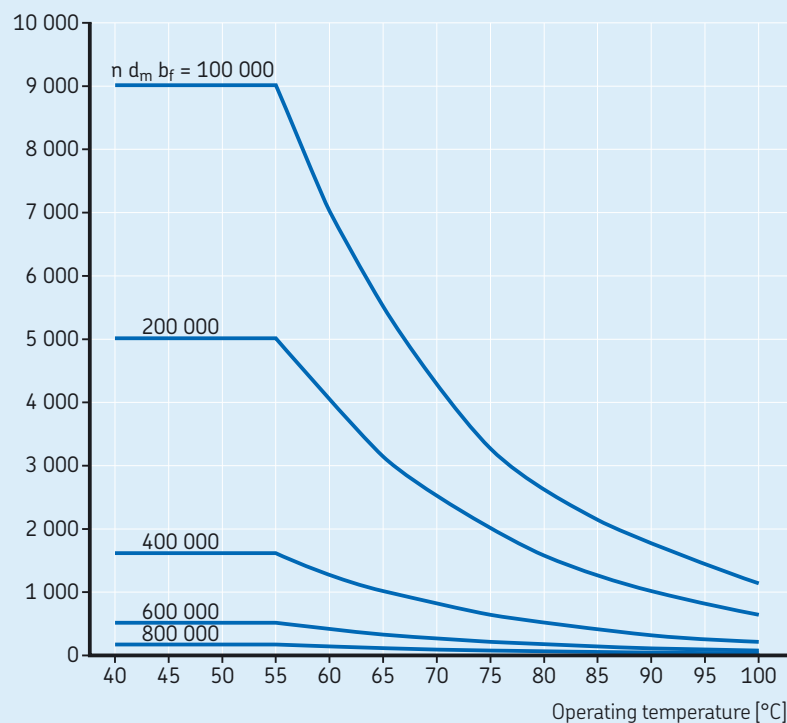

Table 2

Grease quantity for relubrication of SKF ConCentra roller bearing units

Bearing unit Basic designation	Grease quantity
–	g
SYNT 35 FYNT 35	3
SYNT 40 FYNT 40	4
SYNT 45 FYNT 45	4
SYNT 50 FYNT 50	4
SYNT 55 FYNT 55	5
SYNT 60 FYNT 60	6
SYNT 65 FYNT 65	7
SYNT 70 FYNT 70	8
SYNT 75 FYNT 75	8
SYNT 80 FYNT 80	9
SYNT 90 FYNT 90	13
SYNT 100 FYNT 100	17

Grease life for the relubrication-free variant

The grease used in SKF relubrication-free roller bearing units can adequately lubricate the bearings throughout their service life provided the unit is suitable for the operating conditions. The relationship between operating conditions and grease service life shown in **diagram 4** is a function of:

- the operating temperature [°C]
- the speed factor $A = n d_m$

where

- A = speed factor [mm/min]
- n = rotational speed [r/min]
- d_m = bearing mean diameter [mm]
(→ **table 3, page 15**)

Provided the operating range of the bearing unit falls within the shaded area of **diagram 4**, the bearing unit can attain a grease life $L_{50h} = 100\ 000$ hours or more.

Calculation example

An SKF ConCentra roller bearing unit with a plummer block housing is required for an industrial air handling unit. The following application information is known:

- required grease life $L_{50h} = 100\ 000$ hours
- equivalent dynamic bearing load $P = 7$ kN
- rotational speed $n = 1\ 800$ r/min
- shaft diameter $d_a = 60$ mm
- environmental conditions: relatively clean
- expected operating temperature: $55\ ^\circ\text{C}$

Based on the shaft diameter provided and plummer block housing requirement, the bearing unit SYNT 60 is selected. As the application is an industrial air handling unit in a relatively clean environment, the relubrication-free variant would be a most suitable choice.

From the product table, the basic dynamic load rating $C = 156$ kN and when $C/P = 156/7 = 22,3$, $P = 0,045 C$.

Therefore, the bearing unit meets the conditions of use for relubrication-free variants, where $P \leq 0,05 C$.

For $d_m = 85$ mm (→ **table 3, page 15**)

$$A = n d_m = 1\ 800 \times 85 = 153\ 000 \text{ mm/min}$$

Using **diagram 4**, the intersection point of the calculated speed factor and expected operating temperature of $55\ ^\circ\text{C}$ is located in the shaded area.

The bearing unit SYNT 60 FW (or SYNT 60 LW) meets the grease life requirement and is therefore suitable for the application.

Diagram 4

Temperature-speed relationship for relubrication-free SKF ConCentra roller bearing units

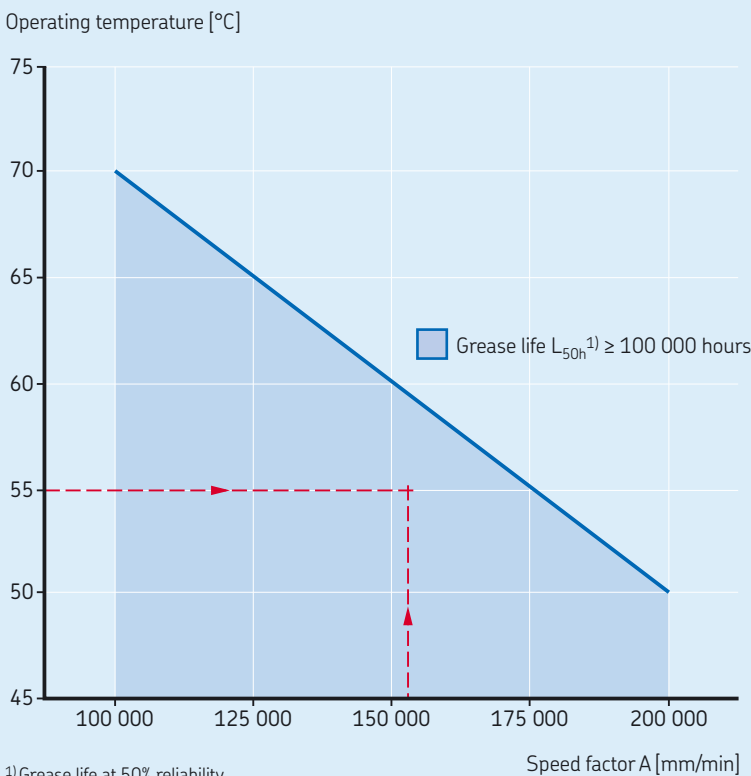

Condition monitoring

SKF recommends monitoring the condition of SKF ConCentra roller bearing units at regular intervals or continuously to assess the condition of the bearing units and detect bearing damage at an early stage. The most reliable way to do this is through vibration analysis.

Bearing units in the SYNT series are prepared for condition monitoring as they have three flat surfaces cast into the housing. The surfaces are located at the 12, 9 and 3 o'clock positions when viewing the housing from the mounting collar side. Accelerometers with magnets that can accommodate rounded surfaces can be attached to bearing units in the FYNT series.

SKF has a wide assortment of condition monitoring equipment, from light hand-held vibration pens to complex inspection systems.

Repainting the housing

The housings of SKF ConCentra roller bearing units can be repainted, if desired. SKF recommends taking the following precautions, prior to painting:

- Cover the housing bore and bearing at both ends, for example with discs cut from cardboard or plastic. This is particularly important to prevent possible bearing contamination and seal damage when using chemicals or abrasive paper to prepare the housing surface.
- Replace the grease fitting with a plug to protect the thread in the housing.
- Do not remove the thin transparent foil covering the designation label. This can be peeled off once the painting is finished.

To avoid peeling effects on the surface when washing repainted housings with washing chemicals, it is important to follow the instructions from the supplier about the concentration and temperature of the chemicals as well as the permissible duration of application.

SKF MARLIN I-Pro and SKF Machine Condition Detector

The SKF MARLIN family of hand-held mobile computers and compatible accessories combines ease of use with advanced technologies that automate inspection processes in virtually any type of facility.



SKF Microlog Analyzer MX series

The MX series, portable maintenance instrument, redefines traditional approaches to vibration analysis and simplifies industrial maintenance, servicing and inspection techniques.



Mounting and dismounting

To realize maximum performance and help prevent premature bearing damage, a clean work environment is essential when mounting SKF ConCentra roller bearing units. In addition, SKF recommends leaving the bearing units in their original package until immediately before mounting so that they are not exposed to contaminants unnecessarily.

Bearing units can also be damaged during dismounting and should therefore be handled with care during this operation. If the bearing units are not already damaged and are dismounted carefully, they might be used again. Even if the bearing units are damaged, be careful when dismounting so as not to cause additional damage that could interfere with any failure analysis.

Methods and tools

The mounting collar of SKF ConCentra roller bearing units is equipped with M6 grub screws, the number of which depends on the bearing unit size. SKF recommends using a torque wrench to tighten these grub screws. The tightening torque is 7,4 Nm. A specially designed hexagonal key 3L, in accordance with ISO 2936:2001, with a torque indicator is supplied with each bearing unit as a secondary option.

When the grub screws are tightened to the recommended torque, the appropriate clearance in the bearing is achieved. A preloaded wave spring facilitates the dismounting of the bearing unit when the grub screws are loosened.

Mounting instructions

Mounting instructions for SKF ConCentra roller bearing units are provided as follows:

- for units with a plumber block housing on **page 26**
- for units with a flanged housing on **page 28**

Note

Do not tighten the grub screws until the bearing unit is positioned on the shaft. If the screws are tightened prematurely, the stepped sleeve may deform. Auxiliary equipment such as hammers or pipes should never be used to tighten the grub screws.

Using a torque wrench

The grub screws in the mounting collar of SKF ConCentra roller bearing units are positioned at an angle to the horizontal, enabling easy access with a torque wrench. The tightening torque is 7,4 Nm.



Using a hexagonal key

The torque indicator supplied with the hexagonal key prevents the grub screws from being under- or over-tightened.



Mounting SKF ConCentra roller bearing units with a plummer block housing

- 1 Make sure that the support surface and the bases of both bearing units are clean and free from burrs.
- 2 Check the flatness and surface roughness of the support surface (→ *Support surface requirements*, page 18). If shims are used, the entire contact surface must be covered.
- 3 Remove any burrs on the shaft with emery cloth and wipe the shaft clean with a lint-free cloth.
- 4 Check the dimensional and form accuracy of the shaft (→ *Shaft requirements*, page 18).
- 5 Mount any necessary components on the shaft between the two bearing unit positions.
- 6 Coat the shaft seats with a thin layer of light oil.
- 7 With the mounting collar facing outward, slide the locating and non-locating bearing units onto the shaft and into position at the drive and non-drive ends of the shaft respectively. Take into consideration that during mounting, the units will be displaced axially on the stepped sleeve.
- 8 Fasten the bearing units to the support surface with suitable attachment bolts and tighten lightly (a).
- 9 Adjust the position of the bearing units and shaft if necessary. Centre lines in the housing base can facilitate this.

- 10 To secure the locating bearing unit onto the shaft, tighten the grub screws in the mounting collar "finger tight". Then tighten each screw 1/4 of a turn, according to the tightening pattern shown.
 - When a 3 mm bit and torque wrench is used, tighten each grub screw to 7,4 Nm (b).
 - When the supplied hexagonal key is used, mount the red torque indicator on the short end of the hexagonal key and tighten each grub screw until the key makes contact with the torque indicator (c).
- 11 Fully tighten the attachment bolts of the locating bearing unit to the recommended tightening torque listed in table 1.
- 12 Find the middle of the non-locating bearing unit seat in the housing by supporting the shaft and pushing the bearing from one end position in the housing to the other, while keeping the housing fixed (d). If only thermal elongation of the shaft is expected, position the non-locating bearing further in the direction of the locating bearing. Be careful to only push the bearing and not the housing.
- 13 To secure the non-locating bearing unit onto the shaft and to the support surface, follow steps 10 and 11 above.
- 14 Remove the shaft support.
- 15 Check that any misalignment of the shaft relative to the bearing units is less than 1,5°.
- 16 Where applicable, snap the end cover into the housing bore recess.

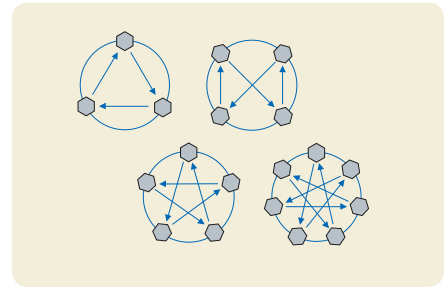

Tightening pattern for grub screws

Table 1

Recommended tightening torques for attachment bolts to strength class 8.8

Bearing unit Basic designation	Attachment bolts	
	Size	Tightening torque
–	–	Nm
SYNT 35 FYNT 35	M12	80
SYNT 40 FYNT 40	M12	80
SYNT 45 FYNT 45	M12	80
SYNT 50 FYNT 50	M12	80
SYNT 55 FYNT 55	M12	80
SYNT 60 FYNT 60	M12	80
SYNT 65 FYNT 65	M16	200
SYNT 70 FYNT 70	M16	200
SYNT 75 FYNT 75	M16	200
SYNT 80 FYNT 80	M16	200
SYNT 90 FYNT 90	M20	385
SYNT 100 FYNT 100	M20	385

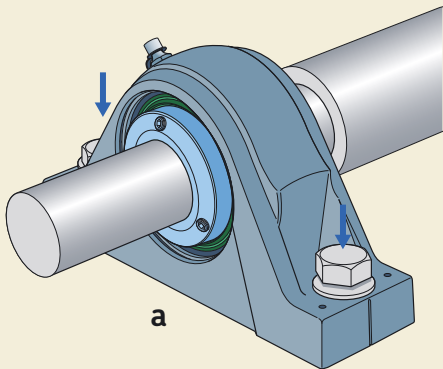

a

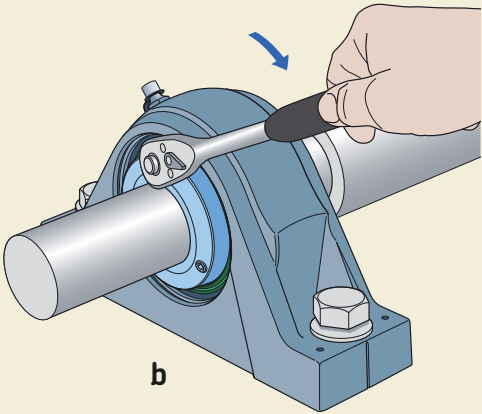

b

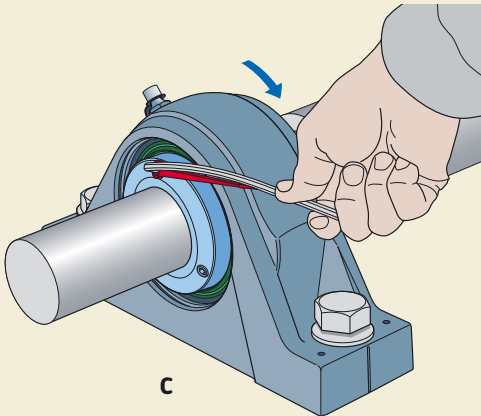

c

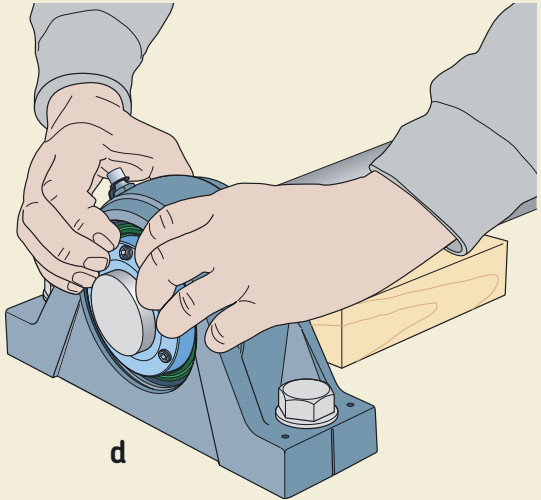

d

Mounting SKF ConCentra roller bearing units with a flanged housing

- 1 Make sure that the mounting surface and the bases of both bearing units are clean and free from burrs.
- 2 Check the flatness and surface roughness of the mounting surface (→ *Support surface requirements, page 18*). If shims are used, the entire contact surface must be covered.
- 3 Remove any burrs on the shaft with emery cloth and wipe the shaft clean with a lint-free cloth.
- 4 Check the dimensional and form accuracy of the shaft (→ *Shaft requirements, page 18*).
- 5 Mount any necessary components on the shaft between the two bearing unit positions.
- 6 Coat the shaft seats with a thin layer of light oil.
- 7 Support the shaft and its components.
- 8 Slide the locating bearing unit onto the drive end of the shaft.
- 9 Position the bearing unit against its mounting surface. For units with a triangular shaped flange, the grease fitting should be at the top. The centre lines on the side of the flange can be used to locate the centre position of the bearing. Where applicable, use the shoulders on the mounting surface to centre and align the bearing unit.
- 10 Fasten the bearing unit to the mounting surface with the attachment bolts and tighten the bolts lightly (a).
- 11 Follow steps 8 to 10 for the non-locating bearing unit. Make sure the bearing in the non-locating unit is pushed toward the mounting collar side before the unit is positioned on the shaft.
- 12 Adjust the axial position of the shaft, if necessary. Take into consideration that during mounting, the units will be displaced axially on the stepped sleeve.
- 13 Start to secure the locating bearing unit onto the shaft. Tighten the grub screws in the mounting collar "finger tight". Then tighten each screw $\frac{1}{4}$ of a turn, according to the tightening pattern shown.
 - When a 3 mm bit and torque wrench is used, tighten each grub screw to 7,4 Nm (b).
 - When the supplied hexagonal key is used, mount the red torque indicator on the short end of the hexagonal key and tighten the grub screw until the key comes in contact with the torque indicator (c).
- 14 Fully tighten the attachment bolts of the locating bearing unit to the recommended tightening torque listed in **table 1** on **page 26**.
- 15 Push the bearing approximately 2 mm from the end position toward the locating bearing. This will position the bearing in the middle of the bearing seat. If only thermal elongation of the shaft is expected, position the non-locating bearing further in the direction of the locating bearing.
- 16 Follow steps 13 and 14 for the non-locating bearing unit.
- 17 Remove the shaft support.
- 18 Check that any misalignment of the shaft relative to the bearing units is less than $1,5^\circ$.
- 19 Where applicable, snap the end cover into the housing bore recess.

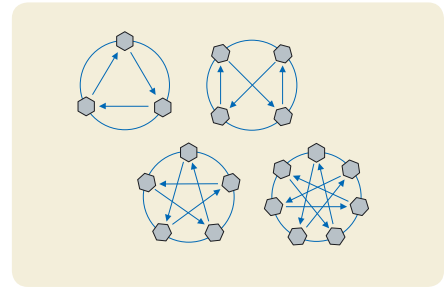

Tightening pattern for grub screws

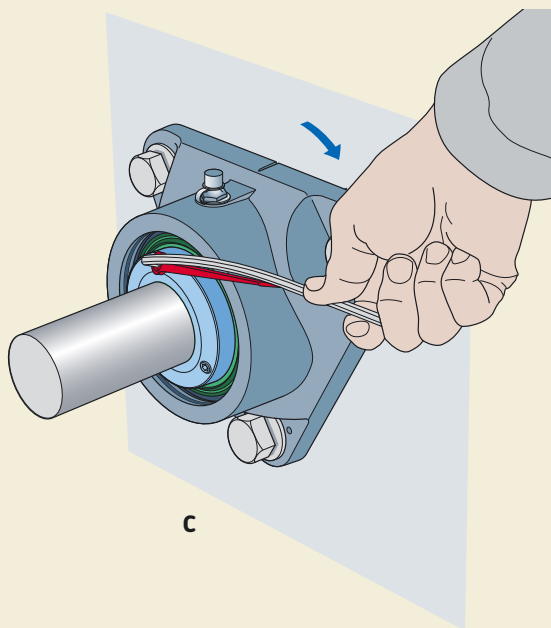
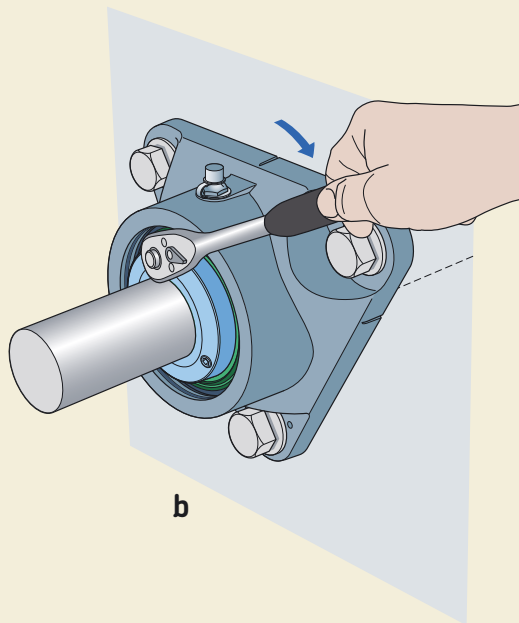
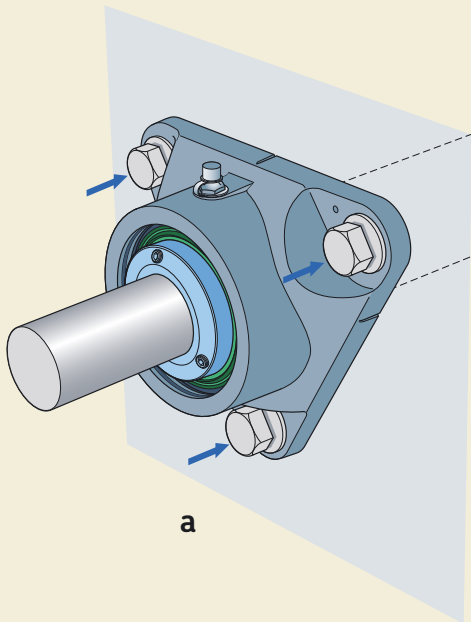

Dismounting instructions

Dismounting instructions for SKF ConCentra roller bearing units are provided as follows:

- for units with a plummer block housing
- for units with a flanged housing on **page 32**

Dismounting SKF ConCentra roller bearing units with a plummer block housing

- 1 Clean the external surfaces of both bearing units.
- 2 Remove the end cover, if present.
- 3 Clean the internal hexagon of the grub screws in the mounting collar of both the bearing units.
- 4 Remove any rust or surface damage from the shaft extension with emery cloth.
- 5 Start with the locating bearing unit. Loosen the attachment bolts and remove them. If possible, SKF recommends lifting the complete bearing arrangement i.e. shaft, both bearing units and associated components out first, before dismounting the bearing units **(a)**.
- 6 Place a support under the shaft.
- 7 Loosen the grub screws in the mounting collar by a few turns **(b)**.
- 8 Face the mounting collar and while holding the base, pull the bearing unit until it releases from the shaft **(c)**. The energy from the preloaded wave spring will facilitate the release of the bearing unit from the shaft. But if necessary, use a rubber hammer to tap the back-up ring on the opposite side of the unit **(d)**.
- 9 Withdraw the bearing unit from the shaft.
- 10 Dismount the non-locating bearing unit in the same way as the locating bearing unit, repeating steps 5 to 9.

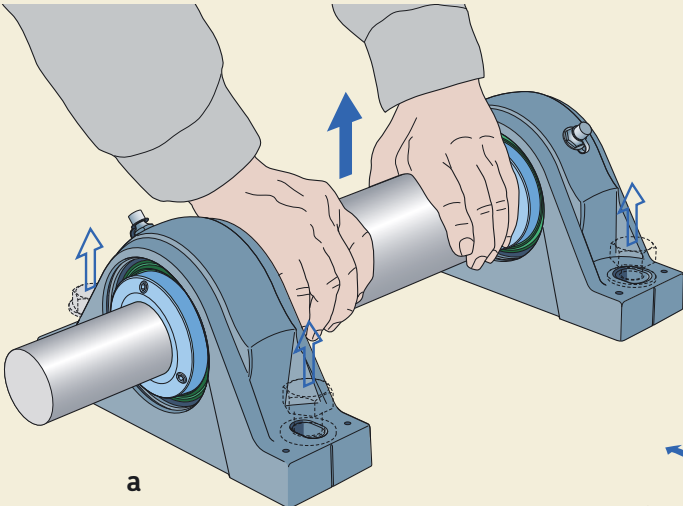

a

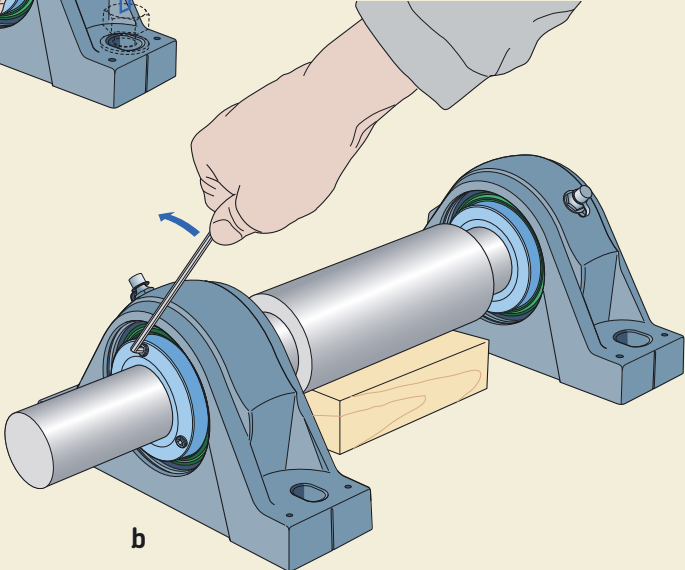

b

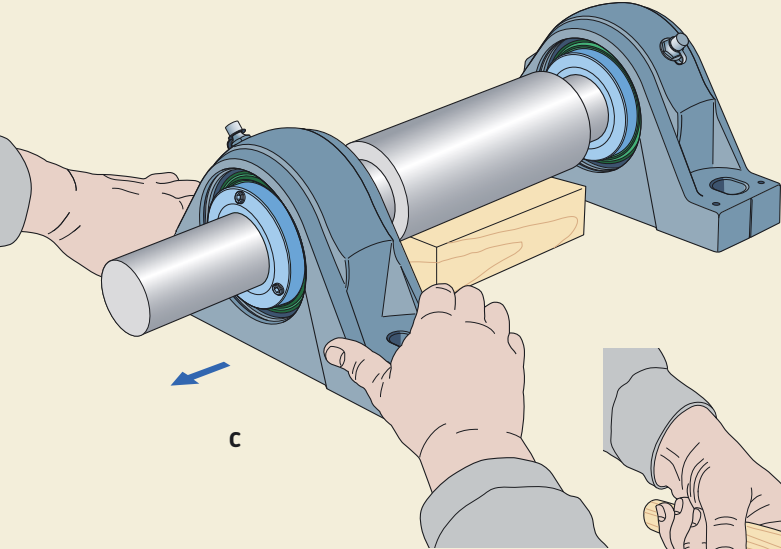

c

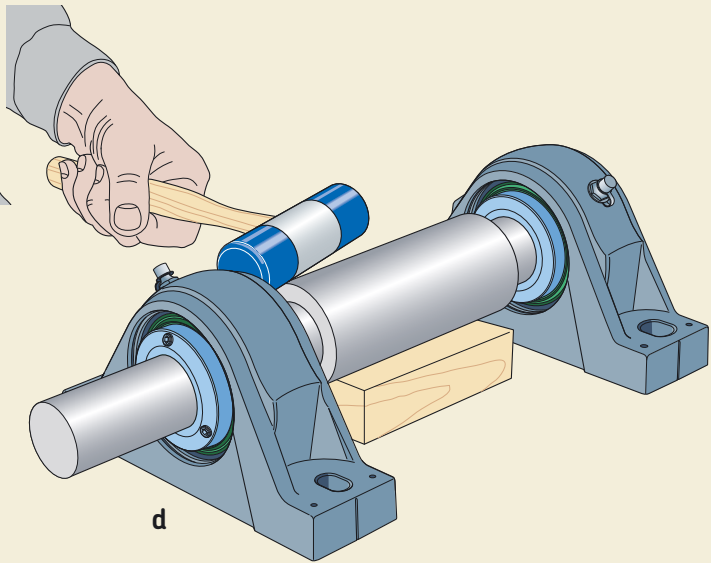

d

Dismounting SKF ConCentra roller bearing units with a flanged housing

- 1 Clean the external surfaces of both bearing units.
- 2 Remove the end cover, if present.
- 3 Clean the internal hexagon of the grub screws in the mounting collar of both the bearing units.
- 4 Remove any rust or surface damage from the shaft extension with emery cloth.
- 5 Support the shaft and its components.
- 6 Start with the locating bearing unit. Loosen the grub screws in the mounting collar by a few turns (**a**).
- 7 Loosen the attachment bolts and remove them.
- 8 Separate the bearing unit from the mounting surface using an appropriate tool such as a screwdriver.
- 9 Face the mounting collar of the bearing unit and while holding the housing, pull the bearing unit until it releases from the shaft (**b**). The energy from the preloaded wave spring will facilitate the release of the bearing unit from the shaft. But if necessary, use a rubber hammer to tap the end of the shaft.
- 10 Withdraw the bearing unit from the shaft.
- 11 Dismount the non-locating bearing unit in the same way as the locating bearing unit, repeating steps 6 to 10.

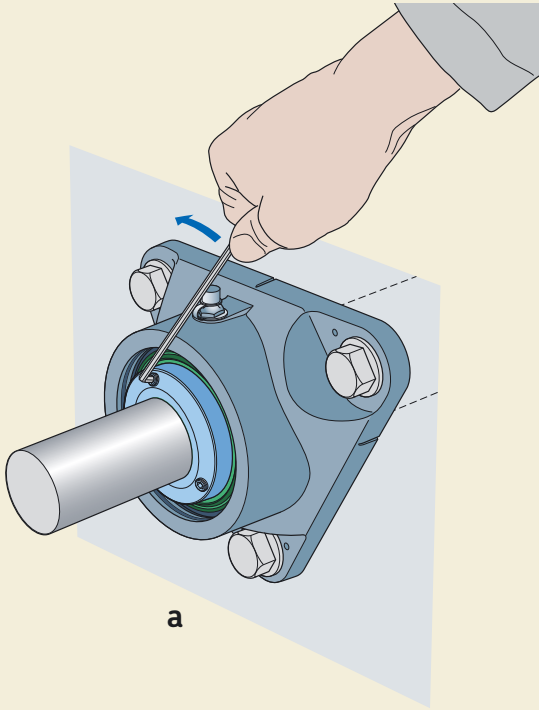

a

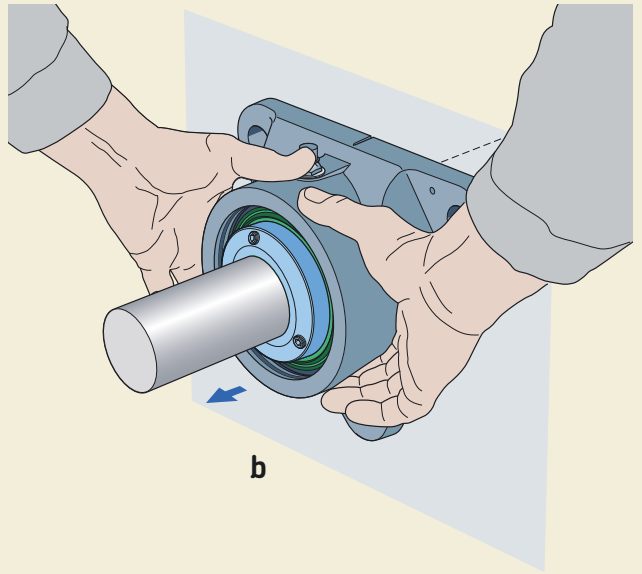

b

Product data – general

Boundary dimensions

The boundary dimensions of SKF ConCentra roller bearing units with a plummer block housing in the SYNT series are in accordance with ISO 113:1999. These bearing units are dimensionally interchangeable with SKF plummer block housings in the SNL 5 series.

The boundary dimensions of SKF ConCentra roller bearing units with a flanged housing in the FYNT series are not standardized either nationally or internationally, but are common in the marketplace. These bearing units are dimensionally interchangeable with housings in the FNL series.

Radial internal clearance

Bearings in SKF ConCentra roller bearing units are manufactured with radial internal clearance identical to C3 radial clearance of spherical roller bearings with a tapered bore. The clearance values, in accordance with ISO 5753:1991, are provided in **table 1** and are valid for unmounted bearing units under zero measuring load.

Misalignment

SKF ConCentra roller bearing units can accommodate angular misalignments of up to 1,5° between the bearing unit positions.

Speeds

The speeds at which SKF ConCentra roller bearing units can be operated depend on the type of seal used in the bearing unit. For bearing units fitted with double-lip or heavy-duty radial shaft seals, the limiting speeds are based on the permissible circumferential speed at the seal lips. For bearing units fitted with labyrinth seals, the limiting speeds are imposed by the bearing size and the grease.

Guideline values for the limiting speeds are listed in the product tables.

Corrosion protection

All SKF ConCentra roller bearing housings are made of grey cast iron. The housings are painted black to RAL 9005. The paint offers protection against rust as specified by category C2 in accordance with ISO 12944-2:1998.

Table 1

Radial internal clearance of bearings in SKF ConCentra roller bearing units

Bore diameter		Radial internal clearance	
d over	incl.	min	max
mm		µm	
30	40	50	65
40	50	60	80
50	65	75	95
65	80	95	120
80	100	110	140

Load carrying ability of the housings

SKF ConCentra roller bearing units in the SYNT series are designed for radial loads acting in the direction of the support surface. Guideline values for the breaking load P of housings in the SYNT series for various load directions are listed in **table 2**. Guideline values for the breaking load P of housings in the FYNT series for various load directions are listed in **table 3**. If heavy loads are expected, additional supports are recommended to relieve the attachment bolts of the load.

Using the values in the tables, the permissible load for the housings in both series can be obtained by applying a safety factor that depends on the operating conditions and reliability requirements. A safety factor of 6 is typically used for general applications.

Table 2

Breaking loads for housings of SKF ConCentra roller bearing units in the SYNT series

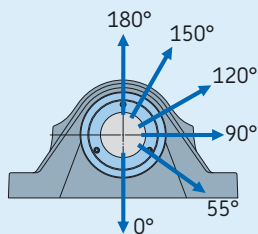

Bearing unit Basic designation	Breaking load in the direction of					
	P_{0° ¹⁾	P_{55°	P_{90°	P_{120°	P_{150°	P_{180°
–	kN					
SYNT 35	150	250	150	95	85	105
SYNT 40	160	265	160	100	90	110
SYNT 45	170	280	170	110	100	115
SYNT 50	190	330	200	130	115	140
SYNT 55	210	350	210	140	120	150
SYNT 60	270	365	220	150	130	170
SYNT 65	290	380	230	155	140	210
SYNT 70	350	400	240	160	145	215
SYNT 75	370	415	250	165	150	220
SYNT 80	430	480	290	205	190	240
SYNT 90	470	620	370	280	250	310
SYNT 100	600	680	410	310	275	340

¹⁾ The values for P_{0° are valid when the housing is not supported in the middle of the base plate, i.e. the space between the reinforcement ribs in the base plate.

Table 3

Breaking loads for housings of SKF ConCentra roller bearing units in the FYNT series

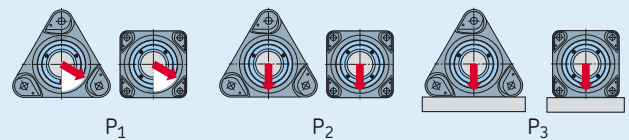

Bearing unit Basic designation	Breaking load in the direction of		
	P_1	P_2	P_3
–	kN		
FYNT 35	80	55	95
FYNT 40	90	60	100
FYNT 45	100	65	105
FYNT 50	110	80	110
FYNT 55	120	95	115
FYNT 60	130	110	190
FYNT 65	140	125	265
FYNT 70	150	140	340
FYNT 75	160	155	415
FYNT 80	170	170	490
FYNT 90	180	185	565
FYNT 100	190	200	640

Axial holding power

The axial holding power of an SKF Con-Centra roller bearing unit depends on the friction between the shaft and the locking device. It is therefore also dependent on the number of grub screws in the mounting collar (→ **table 4**).

When mounted correctly, the bearing units can withstand typical shock loads equivalent to the requisite axial holding force. However, the maximum operating axial load is limited by the rated bearing life through the equivalent bearing load P (→ *Equivalent dynamic bearing load*, page 14).

Table 4

Axial holding power of SKF ConCentra roller bearing units

Bearing unit		No. of grub screws	Axial holding power ¹⁾
Basic designation			
–		–	kN
SYNT 35	FYNT 35	3	15
SYNT 40	FYNT 40	3	15
SYNT 45	FYNT 45	3	15
SYNT 50	FYNT 50	3	15
SYNT 55	FYNT 55	3	15
SYNT 60	FYNT 60	3	15
SYNT 65	FYNT 65	4	20
SYNT 70	FYNT 70	4	20
SYNT 75	FYNT 75	5	25
SYNT 80	FYNT 80	5	25
SYNT 90	FYNT 90	7	35
SYNT 100	FYNT 100	7	35

¹⁾ Not equivalent to the axial load carrying capacity of the bearing unit.

Designation system

The complete designation of an SKF ConCentra roller bearing unit consists of:

- the housing series
- the bearing unit size, specified by the bore diameter
- the type of arrangement
- the variant

The designation system for metric SKF ConCentra roller bearing units is provided in **table 5** together with the definitions.



Table 5

Designation system for metric SKF ConCentra roller bearing units		Examples	SYNT 45 LW	FYNT 60 F
			SYNT	FYNT
			45	60
			L	F
				W
Housing series				
SYNT	Plummer block housing			
FYNT	Flanged housing ¹⁾			
Bearing unit size				
35 to 100	35 mm bore diameter to 100 mm bore diameter			
Type of arrangement				
F	Locating unit			
L	Non-locating unit			
Variant				
-	General (with double-lip seals)			
TS	High-speed (with labyrinth seals)			
TF	Extreme environment (with heavy-duty radial shaft seals)			
W	Relubrication-free (with double-lip seals)			

¹⁾ Only available in the general variant.

SKF ConCentra roller bearing units with a plummer block housing

d_a 35 – 100 mm

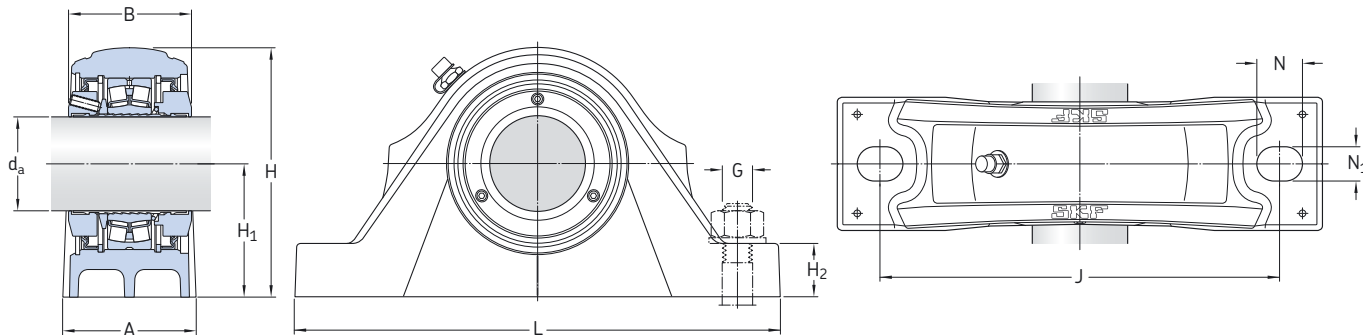

Shaft diameter d _a	Bearing unit dimensions										Mass	Designations	
	A	B	H	H ₁	H ₂	J	L	N	N ₁	G		Locating	Non-locating
mm	mm										kg	–	
35	60	65	111	60	25	170	205	20	15	12	3,80	SYNT 35 F	SYNT 35 L
40	60	65	114	60	25	170	205	20	15	12	3,80	SYNT 40 F	SYNT 40 L
45	60	65	118	60	25	170	205	20	15	12	4,00	SYNT 45 F	SYNT 45 L
50	70	65	131	70	28	210	255	24	18	16	5,80	SYNT 50 F	SYNT 50 L
55	70	66	137	70	30	210	255	24	18	16	6,00	SYNT 55 F	SYNT 55 L
60	80	71	151	80	30	230	275	24	18	16	7,70	SYNT 60 F	SYNT 60 L
65	80	72	158	80	30	230	280	24	18	16	8,70	SYNT 65 F	SYNT 65 L
70	90	72	176	95	32	260	315	28	22	20	11,0	SYNT 70 F	SYNT 70 L
75	90	72	180	95	32	260	320	28	22	20	12,0	SYNT 75 F	SYNT 75 L
80	100	72	191	100	35	290	345	28	22	20	20,0	SYNT 80 F	SYNT 80 L
90	110	86	216	112	40	320	380	32	26	24	21,0	SYNT 90 F	SYNT 90 L
100	120	86	238	125	45	350	410	32	26	24	30,0	SYNT 100 F	SYNT 100 L

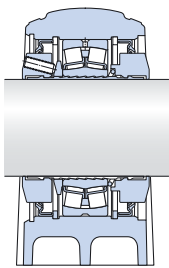

General variant

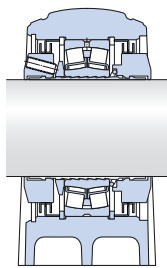

High-speed variant
Designation suffix TS

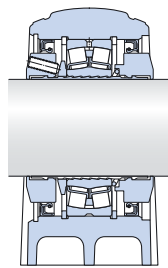

Extreme environment variant
Designation suffix TF

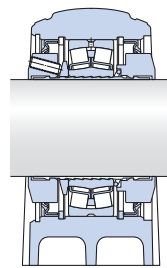

Relubrication-free variant
Designation suffix W

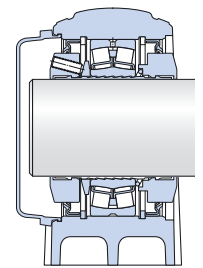

End cover

Shaft diameter d_a	Basic bearing designation	Basic load ratings		Fatigue load limit P_u	Limiting speeds of unit variants				End cover designation
		dynamic C	static C_0		General	High-speed	Extreme environment	Relubrication-free ¹⁾	
mm	–	kN	kN	kN	r/min				–
35	22207 E	86,5	85	9,3	4 100	6 500	2 050	4 100	ECY 207
40	22208 E	96,5	90	9,8	3 800	5 900	1 900	3 800	ECY 208
45	22209 E	102	98	10,8	3 500	5 400	1 750	3 500	ECY 209
50	22210 E	104	108	11,8	3 300	4 900	1 650	3 300	ECY 210
55	22211 E	125	137	13,7	3 100	4 500	1 550	3 100	ECY 211
60	22212 E	156	166	18,6	2 900	4 100	1 450	2 900	ECY 212
65	22213 E	193	216	24	2 700	3 800	1 350	2 700	ECY 213
70	22214 E	208	228	25,5	2 600	3 600	1 300	2 600	ECY 214
75	22215 E	212	240	26,5	2 500	3 300	1 250	2 500	ECY 215
80	22216 E	236	270	29	2 300	3 100	1 150	2 300	–
90	22218 E	325	375	39	2 100	2 800	1 050	2 100	–
100	22220 E	425	490	49	2 000	2 500	1 000	2 000	–

¹⁾ Also refer to diagram 4 on page 23.

SKF ConCentra roller bearing units with a flanged housing

d_a 35 – 100 mm

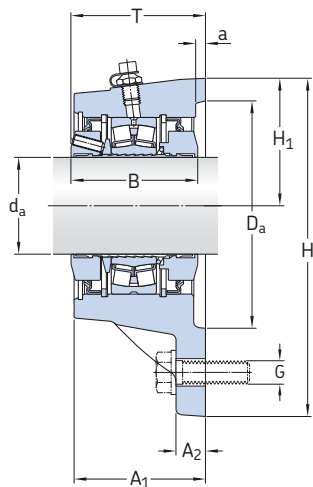

Housing design for shaft diameter 35–60 mm

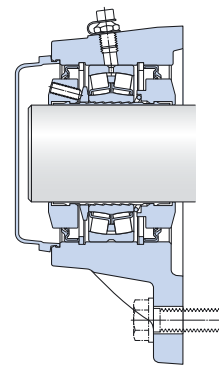
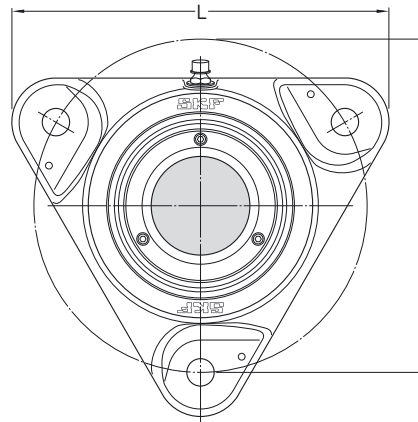

End cover

Shaft diameter d_a	Bearing unit dimensions			B	H	H_1	J	L	G	D_a	a	Mass	Designations General variant	
	A_1	A_2	T_{max}										Locating	Non-locating
mm	mm											kg	–	
35	66	12	72,5	65	143	54	140	159	12	90	4	3,00	FYNT 35 F	FYNT 35 L
40	66	12	72,5	65	160	60	160	179	12	100	4	3,60	FYNT 40 F	FYNT 40 L
45	66	15	72,5	65	160	60	160	179	12	100	5	3,90	FYNT 45 F	FYNT 45 L
50	70	15	72,7	65	172,5	65	170	192	12	105	5	4,50	FYNT 50 F	FYNT 50 L
55	70	15	73,6	66	189	72	180	210	12	120	5	5,90	FYNT 55 F	FYNT 55 L
60	78	15	78,7	71	202,5	77,5	190	225	12	130	5	6,70	FYNT 60 F	FYNT 60 L
65	78	25	80,3	72	–	95	152	190	16	150	6	9,30	FYNT 65 F	FYNT 65 L
70	82	25	81,3	72	–	98	152	196	16	150	6	11,0	FYNT 70 F	FYNT 70 L
75	82	25	81,3	72	–	105	170	210	16	170	6	12,0	FYNT 75 F	FYNT 75 L
80	82,5	25	83	72	–	105	170	210	16	170	7	13,0	FYNT 80 F	FYNT 80 L
90	92	30	93,5	86	–	125	198	250	20	200	6	18,0	FYNT 90 F	FYNT 90 L
100	98	30	98,9	86	–	135	219	270	20	220	6	23,0	FYNT 100 F	FYNT 100 L

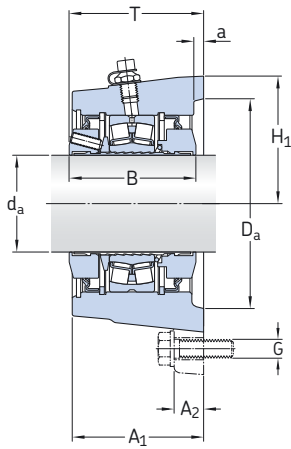

Housing design for shaft diameter 65–100 mm

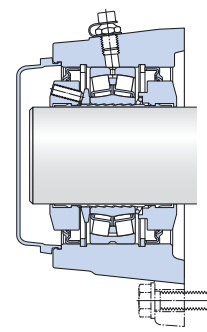
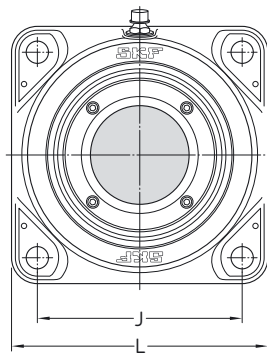

End cover

Shaft diameter	Basic bearing designation	Basic load ratings		Fatigue load limit	Limiting speed	End cover designation
		dynamic	static			
d_a		C	C_0	P_u		
mm	–	kN		kN	r/min	–
35	22207 E	86,5	85	9,3	4 100	ECY 207
40	22208 E	96,5	90	9,8	3 800	ECY 208
45	22209 E	102	98	10,8	3 500	ECY 209
50	22210 E	104	108	11,8	3 300	ECY 210
55	22211 E	125	137	13,7	3 100	ECY 211
60	22212 E	156	166	18,6	2 900	ECY 212
65	22213 E	193	216	24	2 700	ECY 213
70	22214 E	208	228	25,5	2 600	ECY 214
75	22215 E	212	240	26,5	2 500	ECY 215
80	22216 E	236	270	29	2 300	–
90	22218 E	325	375	39	2 100	–
100	22220 E	425	490	49	2 000	–

Other SKF bearing units

In addition to the SKF ConCentra roller bearing units presented in this brochure, the comprehensive SKF assortment includes other ready-to-mount bearing units such as:

- inch size SKF ConCentra roller bearing units
- collar mounted roller bearing units
- SKF ConCentra ball bearing units
- Y-bearing units

Inch size SKF ConCentra roller bearing units

The metric assortment of SKF ConCentra roller bearing units is complemented by various inch size bearing units for shaft diameters ranging from 1 ⁷/₁₆ to 4 in. The bearing units are available as:

- pillow (plummer) block units in the SYR, SYE and FSYE series
- flanged units in the FYR, FYE and FYRP series

These bearing units are interchangeable with similar series collar mounted roller bearing units.

Collar mounted roller bearing units

SKF collar mounted roller bearing units are ready-to-mount, greased and sealed units that can accommodate shaft misalignment relative to the housing. The units are dimensionally interchangeable with similar series inch size SKF ConCentra roller bearing units, differing mainly by the bearing-to-shaft locking method. Instead of a stepped sleeve, the bearings in collar mounted units are secured to the shaft by a locking collar and two grub screws.

Collar mounted roller bearing units are available for 1 ⁷/₁₆ to 4 in. diameter shafts as:

- pillow (plummer) block units in the SYR, SYE and FSYE series
- flanged units in the FYR, FYE and FYRP series

SKF ConCentra ball bearing units

SKF ConCentra ball bearing units were developed for applications where there are relatively high speeds and moderate loads, and where low vibration and noise levels and minimal maintenance are key operational parameters. The units are based on plummer block housings in the SY series, making them dimensionally interchangeable. The bearings are based on deep groove ball bearings in the 62 series.

SKF ConCentra ball bearing units are available as:

- metric units for 25 to 60 mm shaft diameters
- inch size units for 1 to 2 ¹⁵/₁₆ in. shaft diameters



Y-bearing units

Standard SKF ball bearing units are referred to as Y-bearing units. Each unit consists of a single row deep groove ball bearing with an extended inner ring and a convex sphered outside diameter fitted in a housing with a correspondingly concave spherical bore. These ready-to-mount units can accommodate initial misalignment.

SKF Y-bearing units are available as:

- Y-bearing plummer (pillow) block units
- flanged Y-bearing units
- Y-bearing take-up units
- grub screw locking
- eccentric collar locking
- adapter sleeve locking

The bearings and housings can be ordered separately. A large variety of housings made of composite material, grey cast iron and sheet steel, are available as well as rubber cartridges. Several seal and grease fill variants meet specific application requirements and the assortment includes metric and inch size units.

There are also three bearing-to-shaft locking methods:



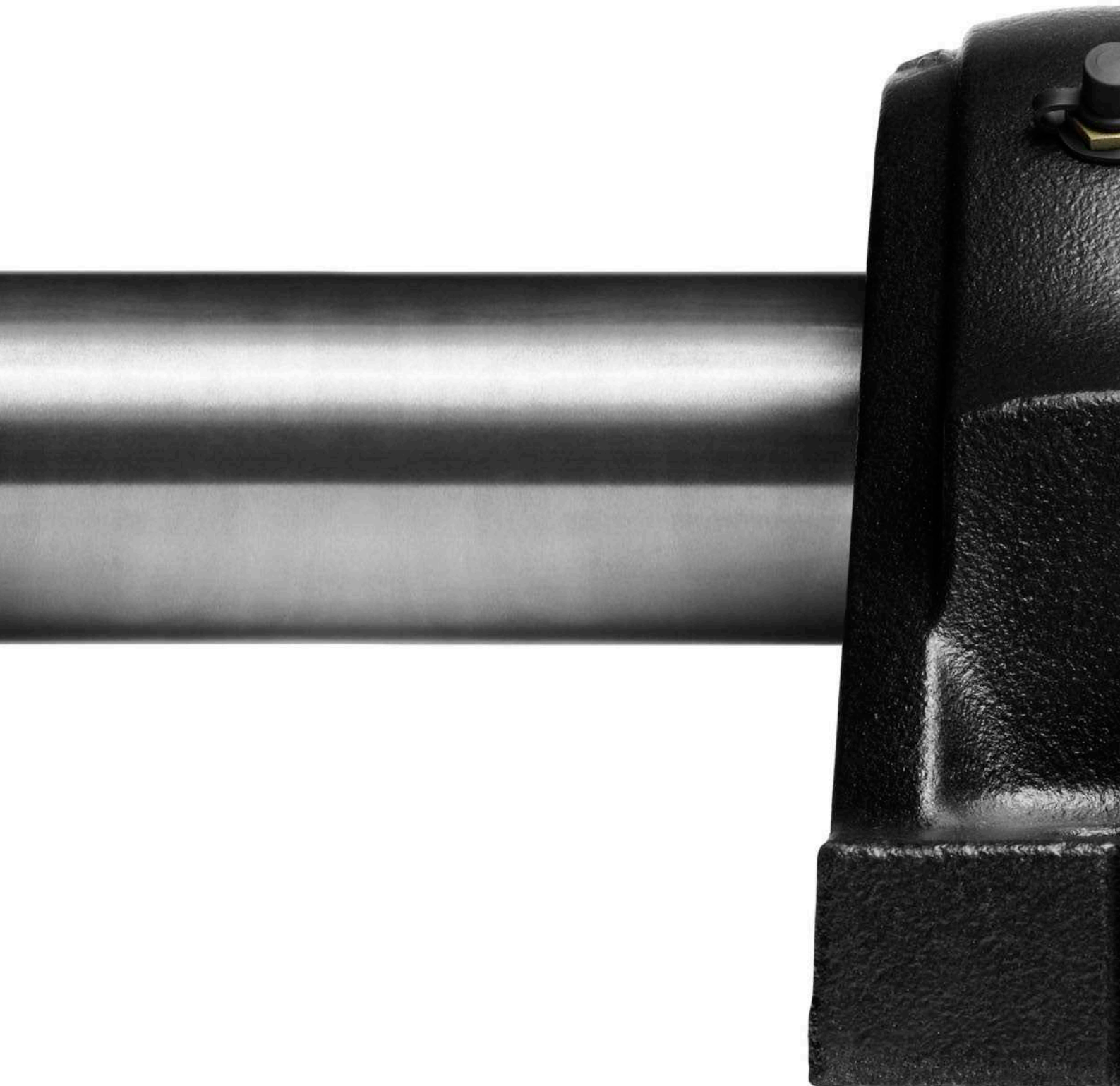



D

SKF – the knowledge engineering company

From the company that invented the self-aligning ball bearing more than 100 years ago, SKF has evolved into a knowledge engineering company that is able to draw on five technology platforms to create unique solutions for its customers. These platforms include bearings, bearing units and seals, of course, but extend to other areas including: lubricants and lubrication systems, critical for long bearing life in many applications; mechatronics that combine mechanical and electronics knowledge into systems for more effective linear motion and sensorized solutions; and a full range of services, from design and logistics support to conditioning monitoring and reliability systems.

Though the scope has broadened, SKF continues to maintain the world's leadership in the design, manufacture and marketing of rolling bearings, as well as complementary products such as radial seals. SKF also holds an increasingly important position in the market for linear motion products, high-precision aerospace bearings, machine tool spindles and plant maintenance services.

The SKF Group is globally certified to ISO 14001, the international standard for environmental management, as well as OHSAS 18001, the health and safety management standard. Individual divisions have been approved for quality certification in accordance with ISO 9001 and other customer specific requirements.

With over 100 manufacturing sites worldwide and sales companies in 70 countries, SKF is a truly international corporation. In addition, our distributors and dealers in some 15 000 locations around the world, an e-business marketplace and a global distribution system put SKF close to customers for the supply of both products and services. In essence, SKF solutions are available wherever and whenever customers need them. Overall, the SKF brand and the corporation are stronger than ever. As the knowledge engineering company, we stand ready to serve you with world-class product competencies, intellectual resources, and the vision to help you succeed.



© Airbus – photo: e*tm company, H. Goussé

Evolving by-wire technology

SKF has a unique expertise in fast-growing by-wire technology, from fly-by-wire, to drive-by-wire, to work-by-wire. SKF pioneered practical fly-by-wire technology and is a close working partner with all aerospace industry leaders. As an example, virtually all aircraft of the Airbus design use SKF by-wire systems for cockpit flight control.

SKF is also a leader in automotive by-wire technology, and has partnered with automotive engineers to develop two concept cars, which employ SKF mechatronics for steering and braking. Further by-wire development has led SKF to produce an all-electric forklift truck, which uses mechatronics rather than hydraulics for all controls.

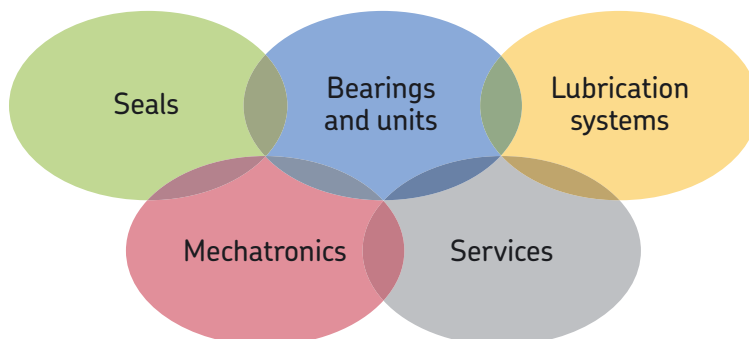



Harnessing wind power

The growing industry of wind-generated electric power provides a source of clean, green electricity. SKF is working closely with global industry leaders to develop efficient and trouble-free turbines, providing a wide range of large, highly specialized bearings and condition monitoring systems to extend equipment life of wind farms located in even the most remote and inhospitable environments.



Working in extreme environments

In frigid winters, especially in northern countries, extreme sub-zero temperatures can cause bearings in railway axleboxes to seize due to lubrication starvation. SKF created a new family of synthetic lubricants formulated to retain their lubrication viscosity even at these extreme temperatures. SKF knowledge enables manufacturers and end user customers to overcome the performance issues resulting from extreme temperatures, whether hot or cold. For example, SKF products are at work in diverse environments such as baking ovens and instant freezing in food processing plants.



Developing a cleaner cleaner

The electric motor and its bearings are the heart of many household appliances. SKF works closely with appliance manufacturers to improve their products' performance, cut costs, reduce weight, and reduce energy consumption. A recent example of this cooperation is a new generation of vacuum cleaners with substantially more suction. SKF knowledge in the area of small bearing technology is also applied to manufacturers of power tools and office equipment.



Maintaining a 350 km/h R&D lab

In addition to SKF's renowned research and development facilities in Europe and the United States, Formula One car racing provides a unique environment for SKF to push the limits of bearing technology. For over 50 years, SKF products, engineering and knowledge have helped make Scuderia Ferrari a formidable force in F1 racing. (The average racing Ferrari utilizes more than 150 SKF components.) Lessons learned here are applied to the products we provide to automakers and the aftermarket worldwide.



Delivering Asset Efficiency Optimization

Through SKF Reliability Systems, SKF provides a comprehensive range of asset efficiency products and services, from condition monitoring hardware and software to maintenance strategies, engineering assistance and machine reliability programmes. To optimize efficiency and boost productivity, some industrial facilities opt for an Integrated Maintenance Solution, in which SKF delivers all services under one fixed-fee, performance-based contract.



Planning for sustainable growth

By their very nature, bearings make a positive contribution to the natural environment, enabling machinery to operate more efficiently, consume less power, and require less lubrication. By raising the performance bar for our own products, SKF is enabling a new generation of high-efficiency products and equipment. With an eye to the future and the world we will leave to our children, the SKF Group policy on environment, health and safety, as well as the manufacturing techniques, are planned and implemented to help protect and preserve the earth's limited natural resources. We remain committed to sustainable, environmentally responsible growth.

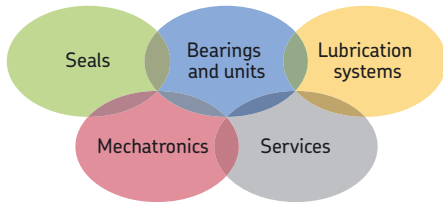

The Power of Knowledge Engineering

Drawing on five areas of competence and application-specific expertise amassed over more than 100 years, SKF brings innovative solutions to OEMs and production facilities in every major industry worldwide. These five competence areas include bearings and units, seals, lubrication systems, mechatronics (combining mechanics and electronics into intelligent systems), and a wide range of services, from 3-D computer modelling to advanced condition monitoring and reliability and asset management systems. A global presence provides SKF customers uniform quality standards and worldwide product availability.

© SKF is a registered trademark of the SKF Group.
™ SKF Explorer and Total Shaft Solutions are trademarks of the SKF Group.

© SKF Group 2010

The contents of this publication are the copyright of the publisher and may not be reproduced (even extracts) unless prior written permission is granted. Every care has been taken to ensure the accuracy of the information contained in this publication but no liability can be accepted for any loss or damage whether direct, indirect or consequential arising out of the use of the information contained herein.

PUB BU/P2 06103/1 EN · February 2010

This publication supersedes all information about metric SKF ConCentra roller bearing units in publication 5103.

Printed in Sweden on environmentally friendly paper.

Certain image(s) used under license from Shutterstock.com

