

25

Lock nuts

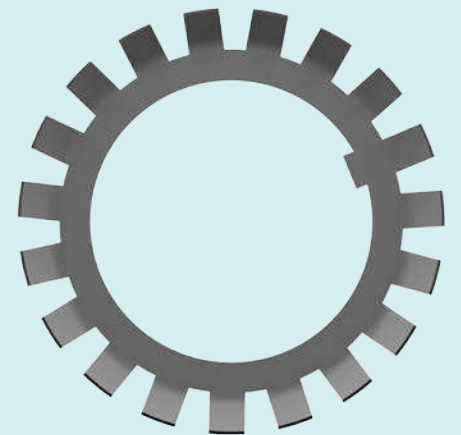
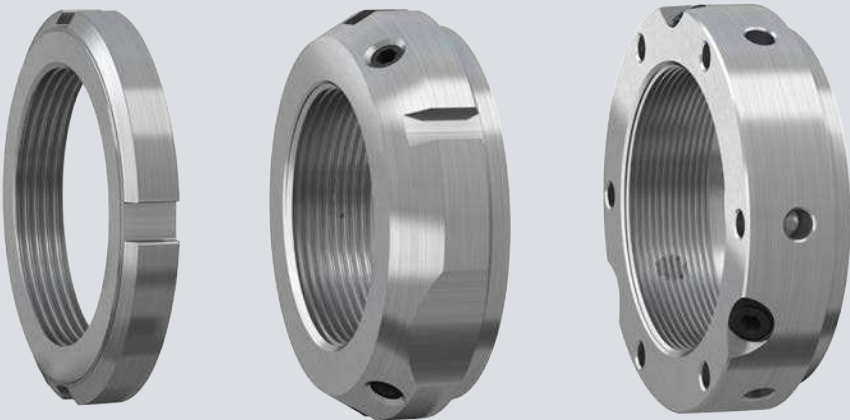

# 25 Lock nuts

<b>Designs and variants</b> . . . . .	<b>1090</b>
Lock nuts requiring a keyway . . . . .	1093
KM, KML and HM .. T metric lock nuts . . . . .	1093
N and AN inch lock nuts . . . . .	1093
HM and HME metric lock nuts . . . . .	1094
The locking principles . . . . .	1094
Lock nuts with integral locking . . . . .	1095
KMFE lock nuts . . . . .	1095
KMK lock nuts . . . . .	1095
The locking principle . . . . .	1095
Precision lock nuts with locking pins . . . . .	1096
The locking principle . . . . .	1097
Precision lock nuts with axial locking screws . . . . .	1097
The locking principle . . . . .	1097
 <b>Product data</b> . . . . .	 <b>1098</b>
(Dimension standards, tolerances, mating shaft threads, loosening torque)	
 <b>Installation and removal</b> . . . . .	 <b>1100</b>
Lock nuts requiring a keyway . . . . .	1100
Using lock nuts with lock washer to lock a bearing . . . . .	1100
Using lock nuts with locking clips to lock a bearing . . . . .	1100
Lock nuts with integral locking . . . . .	1101
Mounting . . . . .	1101
Dismounting . . . . .	1101
Precision lock nuts with locking pins . . . . .	1102
Installation . . . . .	1102
Adjustment . . . . .	1102
Removal . . . . .	1102
 <b>Designation system</b> . . . . .	 <b>1103</b>
 <b>Product tables</b>	
<b>25.1</b> KM(L) and HM .. T lock nuts . . . . .	1104
<b>25.2</b> MB(L) lock washers . . . . .	1106
<b>25.3</b> HM lock nuts . . . . .	1108
<b>25.4</b> MS locking clips . . . . .	1110
<b>25.5</b> KMFE lock nuts with a locking screw . . . . .	1112
<b>25.6</b> KMT precision lock nuts with locking pins . . . . .	1114
<b>25.7</b> KMTA precision lock nuts with locking pins . . . . .	1116

# 25 Lock nuts

Lock nuts are used to locate bearings onto a shaft. Additionally, they can be used to mount bearings with a tapered bore onto tapered shaft seats and adapter sleeves, and to dismount bearings from withdrawal sleeves. Lock nuts are also frequently used to secure gears, belt pulleys and other machine components.

Lock nuts have to be secured to prevent unintentional loosening by:

- a locking device that engages a keyway in the shaft or key slot in the adapter sleeve, or
- a locking mechanism integrated in the nut

When choosing or replacing a lock nut, there are a number of factors that should be taken into consideration. They include, but are not limited to:

- Space – axial and radial
- Shaft rotation – one or both directions
- Axial loads
- Dynamic behaviour of the application
- Cost and downtime of machining keyways in shafts vs. other locking methods
- Ease and frequency of assembly and disassembly
- Precision

## Designs and variants

SKF lock nuts provide a variety of ways to secure the nut onto a shaft. The lock nuts listed here constitute the basic SKF assortment. Lock nuts with other locking methods can be supplied on request. For additional information, contact SKF.

The following tables provide an overview over the basic SKF assortment:

- [table 1](#) for SKF industrial lock nuts
- [table 2, page 1092](#) for SKF precision lock nuts

Lock nuts with integral locking reduce the cost of the shaft as no keyway is required. Installation is quicker and easier because no separate locking device is necessary. However, the loosening torque of these lock nuts requires more attention. For information on loosening torque, refer to *Product data*, [page 1098](#).

Table 1

SKF industrial lock nuts

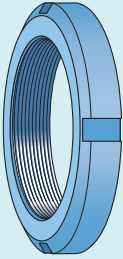
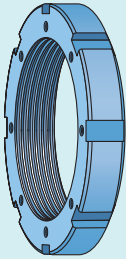
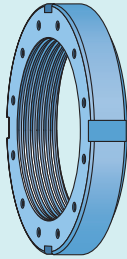
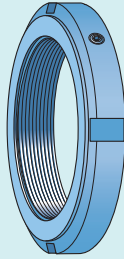
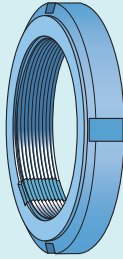
				
<b>KM, KML, HM .. T, AN and N</b> Lock nuts with a lock washer	<b>HM and HME</b> Lock nuts with a locking clip	<b>N</b> Lock nuts with a locking plate	<b>KMFE</b> Lock nuts with an integral locking screw	<b>KMK</b> Lock nuts with an integral locking device
<b>KM and KML:</b> thread 10 to 200 mm (sizes 0 to 40)  <b>HM .. T:</b> thread 210 to 280 mm (sizes 42 to 56)  <b>AN and N:</b> thread 0.391 to 8.628 in. (sizes: N 00 to N 14, AN 15 to AN 40 and N 022 to N 044) These lock nuts are not listed in this catalogue, but can be found online at <a href="http://skf.com/go/17000-25-8">skf.com/go/17000-25-8</a> .	thread 220 to 1 120 mm (sizes 44 to /1120)  HME design lock nuts are not listed in this catalogue, but can be found online at <a href="http://skf.com/go/17000-25-3">skf.com/go/17000-25-3</a> .	thread 9.442 to 37.410 in. (sizes 056 to 950)  These lock nuts are not listed in this catalogue, but can be found online at <a href="http://skf.com/go/17000-25-8">skf.com/go/17000-25-8</a> .	thread 20 to 200 mm (sizes 4 to 40)	thread 10 to 100 mm (sizes 0 to 20)  These lock nuts are not listed in this catalogue, but can be found online at <a href="http://skf.com/go/17000-25-5">skf.com/go/17000-25-5</a> .
A simple, stable and reliable fastening element	A simple, stable and reliable fastening element	A simple, stable and reliable fastening element	Fastened with an integral locking screw and front face adapted for use with certain CARB and sealed bearings	Fastened with a threaded steel insert and a grub screw
Reusable with new locking device	Reusable with new locking device	Reusable with new locking device	Reusable	Reusable
Simple to install and remove	Simple to install and remove	Simple to install and remove	Simple to install and robust locking	Simple to install
Keyway in shaft thread required for lock washer	Keyway in shaft thread required for locking clip	Keyway in shaft thread required for locking plate	For shaft threads without keyways	For shaft threads without keyways

Locking principle

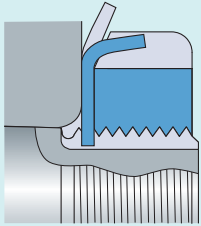
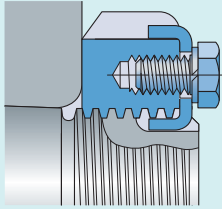
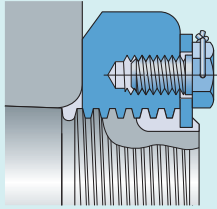
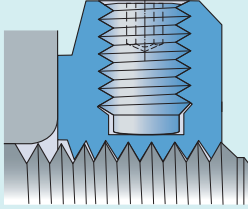
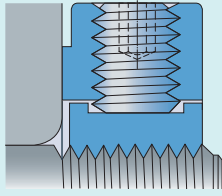
				
Locks with a separate lock washer engaged in a key- way in the shaft thread and having a tab that is bent over into one of the slots in the nut	Locks with a separate lock- ing clip that is attached to the nut and engages with a keyway in the shaft thread and one of the slots in the nut	Locks with a locking plate that engages with a keyway in the shaft thread and is secured to the nut by two screws and locking wire	Locks by tightening the grub screw to press the lock nut thread against the shaft thread	Locks by tightening the grub screws to press a threaded steel insert in the lock nut against the shaft thread

SKF precision lock nuts

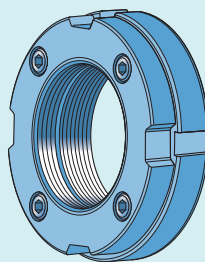
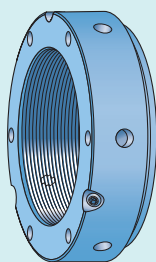
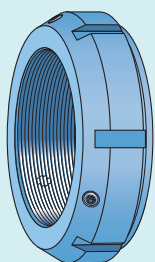

**KMT**

Precision lock nuts with locking pins

**KMTA**

thread 25 to 200 mm  
(sizes 5 to 40)

**KMD**

Precision lock nuts with axial locking screws

thread 10 to 200 mm  
(sizes 0 to 40)  
Larger sizes on request

thread 20 to 105 mm (sizes 4 to 21)  
These lock nuts are not listed in this catalogue, but can be found online at [skf.com/go/17000-25-6](http://skf.com/go/17000-25-6).

Maximum axial run-out between the locating face and thread: 0,005 mm

Maximum axial run-out between the locating face and thread: 0,005 mm

Can be adjusted to compensate for slight angular deviations

Effective axial locking, simple to position

Reusable

Reusable

Simple to install and remove

Simple to install and remove

For shaft threads without keyways

For shaft threads without keyways

Designed for frequent installation and removal

Designed for frequent installation and removal

High axial load capacity

**Locking principle**

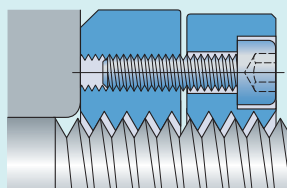
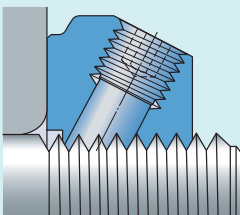

Locks to the shaft thread by friction generated by tightening three radial locking pins with grub screws against its unloaded flanks

Locks to the shaft thread by friction generated by tightening four axial screws that press the rear part of the nut against the unloaded thread flanks

## Lock nuts requiring a keyway

### KM, KML and HM .. T metric lock nuts

KM and KML lock nuts (fig. 1):

- have metric threads
- are designed to be used with lock washers
- have four equally-spaced slots located around their circumference to accommodate a hook or impact spanner (fig. 2)
- are also referred to as shaft or withdrawal nuts
- are available for thread M 10x0,75 to M 200x3 (sizes 0 to 40)
- can be locked with either the MB lock washer (fig. 3) or with a stronger, MB .. A lock washer

KML lock nuts have a lower cross-sectional height than KM lock nuts.

HM .. T lock nuts (fig. 1):

- have metric trapezoidal threads
  - are also referred to as removal nuts
  - are available for thread Tr 210x4 to Tr 280x4 (sizes 42 to 56)
- For some sizes, no lock washer is available because these nuts are intended to dismount bearings with a tapered bore from a withdrawal sleeve.

KM, KML and HM...T lock nuts can be reused, provided they are not damaged. A new lock washer should be used each time the corresponding lock nut is installed.

### Features and benefits

- Simple, stable and reliable fastening
- Wide range of sizes
- Easy to install and remove
- Thread diameters ranging from 10 to 280 mm

## N and AN inch lock nuts

N and AN inch lock nuts (fig. 1):

- using a W lock washer (fig. 3) are available up to and including size 44 (thread diameter 8.628 in.)
- using a locking plate (fig. 4) are low-profile-series lock nuts for nominal thread diameters ranging from 9.442 to 37.410 in. (sizes N 048 to N 950)
- have four, equally spaced slots around their circumference to accommodate a hook or impact spanner (fig. 2)
- are also referred to as shaft or withdrawal nuts
- N 00 to N 14, AN 15 to AN 40 and N 44 lock nuts are normal series lock nuts commonly used together with bearings in the 12, 13, 222, 223 and 232 series up to size 23244, mounted directly to the shaft or via an adapter sleeve.
- N 022 to N 044 lock nuts are low-profile-series lock nuts commonly used together with bearings in the 230 series. They can also be used to secure other bearing types and other machine components.
- N lock nuts with a locking plate are commonly used with bearings in the 230, 231 and 232 series (sizes  $\geq 48$ ), but can also be used to retain any suitable bearing or other machine component.

N and AN lock nuts can be reused, provided they are not damaged. A new lock washer or locking plate should be used each time the corresponding lock nut is installed.

### Features and benefits

- Simple, stable and reliable fastening element
- Wide range of sizes
- Easy to install and remove
- Lock washers available for thread 0.391 to 8.628 in. (sizes 00 to 44)
- Locking plates available for thread 9.442 to 18.894 in. (sizes 048 to 096) and for thread 19.682 to 37.410 in. (sizes 500 to 950)

These lock nuts are not listed in this catalogue, but can be found online at [skf.com/go/17000-25-8](http://skf.com/go/17000-25-8).

Fig. 1

KM, KML, HM .. T, AN and N (size  $\leq 44$ ) lock nut

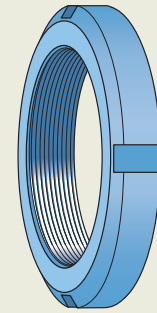

Fig. 2

KM, KML, HM .. T, AN and N (size  $\leq 44$ ) lock nut

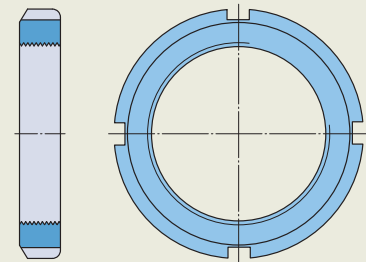

Fig. 3

MB or W lock washer

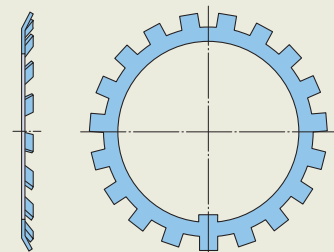
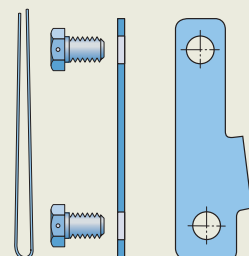

Fig. 4

PL locking plate



## HM and HME metric lock nuts

HM and HME lock nuts (fig. 5):

- have metric trapezoidal threads
- have eight equally-spaced slots located around their circumference to accommodate an impact spanner (fig. 6)
- are located on the shaft by MS locking clips (fig. 7)

When compared to HM lock nuts, HME lock nuts have a recessed side face to accommodate axial displacement of CARB toroidal roller bearings (fig. 8).

HM and HME lock nuts can be reused, provided they are not damaged. A new locking clip should be used each time the corresponding lock nut is reinstalled.

### Features and benefits

- Simple, stable and reliable fastening element
- Wide range of sizes
- Easy to install and remove
- Available for thread Tr 220x4 to Tr 1120x8 (sizes 44 to /1120)

### The locking principles

Lock washers, locking clips and locking plates are simple, stable and reliable fastening elements.

- Lock washers (fig. 3, page 1093) engage a keyway in a shaft, or adapter sleeve thread. The washer locks the nut in position when one of the washer tabs is bent into one of the slots on the nut's outside diameter (fig. 9).
- Locking plates (fig. 4, page 1093) engage a keyway in a shaft or adapter sleeve and are attached to the side face of the nut by two bolts secured with locking wire. A locking plate consists of a plate, two hexagonal head bolts with drilled heads and lock wire to secure them (fig. 10).
- Locking clips (fig. 7) engage a keyway in a shaft or adapter sleeve and one of the slots in the outside diameter of the lock nut. Locking clips are attached to the nut by a bolt (fig. 11).

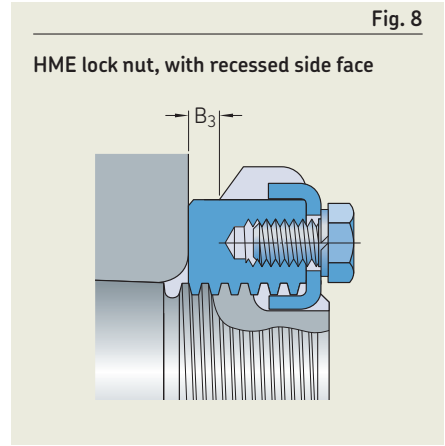

Fig. 8

HME lock nut, with recessed side face

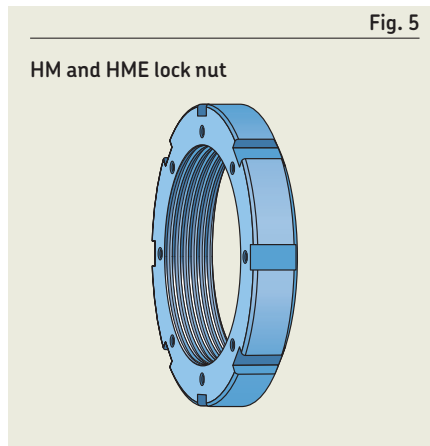

Fig. 5

HM and HME lock nut

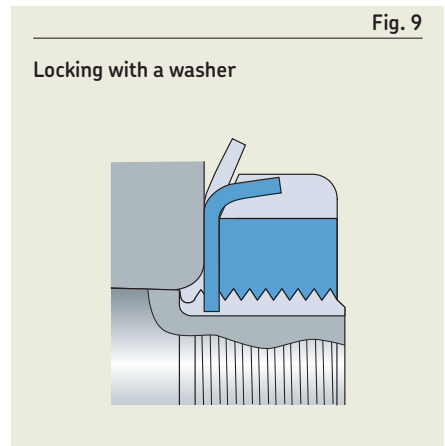

Fig. 9

Locking with a washer

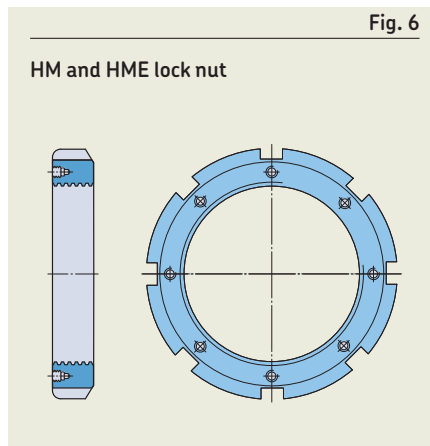

Fig. 6

HM and HME lock nut

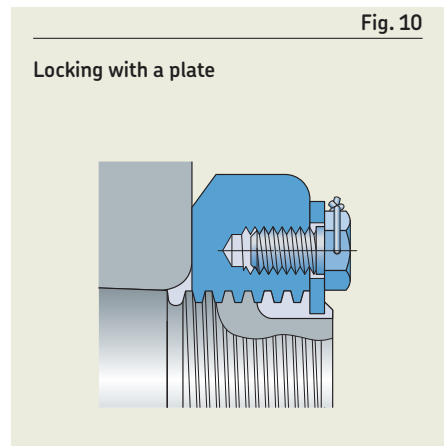

Fig. 10

Locking with a plate

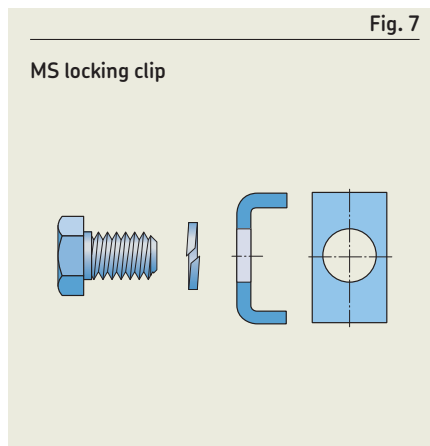

Fig. 7

MS locking clip

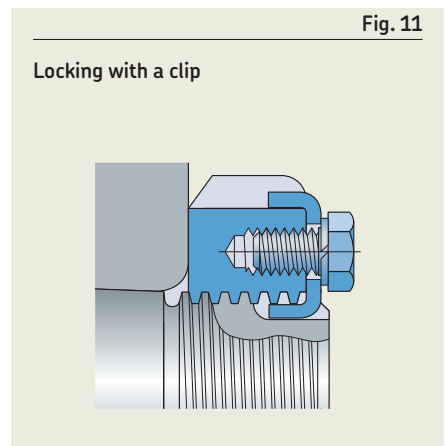

Fig. 11

Locking with a clip

# Lock nuts with integral locking

Lock nuts with integral locking reduce the cost of the shaft as no keyway is required. Installation is quicker and easier because no separate locking device is necessary.

## KMFE lock nuts

KMFE lock nuts (fig. 12):

- are designed to locate CARB toroidal roller bearings, sealed spherical roller bearings and sealed self-aligning ball bearings axially on a shaft
- have appropriate contact faces for the intended bearings
- are available for thread M 20x1 to M 200x3 (sizes 4 to 40)

KMFE lock nuts should not be used on shafts with a keyway. They should only be used with special adapter sleeves with a narrow slot. Damage to the nut can result if the grub screw aligns with a keyway or wide slot. KMFE lock nuts can be reused, provided they are not damaged.

## Features and benefits

- Maximum axial run-out between the locating face and thread: 0,02 to 0,03 mm
- No keyway required
- Simple to install
- Simple and robust locking
- Reusable
- Appropriate contact faces for intended bearings
- Equipped with visual marks for the use of tightening angles

## KMK lock nuts

KMK lock nuts (fig. 13):

- are intended to locate radial bearings in less demanding applications
- are available for thread M 10x0,75 to M 100x2 (sizes 0 to 20)

KMK lock nuts should not be used on shafts with keyways or adapter sleeves with key slots. Damage to the locking device can result if it aligns with a keyway or slot. KMK lock nuts can be reused, provided they are not damaged.

These lock nuts are not listed in this catalogue, but can be found online at [skf.com/go/17000-25-5](http://skf.com/go/17000-25-5).

## The locking principle

Lock nuts with integral locking are locked by friction. The friction is sufficient to lock the nut in place.

KMFE lock nuts have an integral grub (set) screw, to lock the nut in place. When the grub screw is tightened, it causes the nut thread to deform and press against the shaft or sleeve thread (fig. 14).

KMK have a threaded steel insert in their bore. The threads on the insert match the lock nut threads. The insert acts as a pressure plate when a grub screw, which runs through the body of the lock nut, is tightened (fig. 15).

Fig. 12

KMFE lock nut

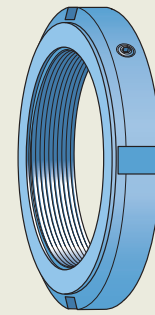

Fig. 13

KMK lock nut

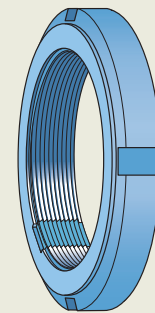

Fig. 14

Locking with a locking screw – KMFE

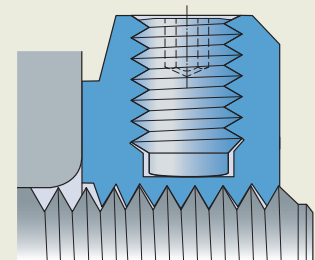
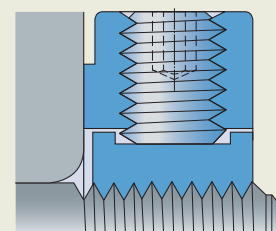

Fig. 15

Locking with an integral locking device – KMK





# Precision lock nuts with locking pins

KMT and KMTA lock nuts are intended for applications where high precision, simple assembly and reliable locking are required<sup>1)</sup>. The three equally-spaced locking pins enable these lock nuts to be accurately positioned at right angles to the shaft. However, they can also be adjusted to compensate for slight angular deviations of adjacent components.

KMT lock nuts (fig. 16):

- are available for thread M 10x0,75 to M 200x3 (sizes 0 to 40)
- are available on request for thread Tr 220x4 to Tr 420x5 (sizes 44 to 84)

KMTA lock nuts (fig. 17):

- are available for thread M 25x1,5 to M 200x3 (sizes 5 to 40)
- have a cylindrical outside surface and, for some sizes, a different thread pitch than KMT lock nuts
- are intended primarily for applications where space is limited and the cylindrical outside surface can be used as an element of a gap-type seal

## Features and benefits

- Maximum axial run-out between the locating face and thread (sizes ≤ 40): 0,005 mm
- Adjustable to compensate for slight angular deviations (fig. 18)
- Fine thread pitch
- Withstands high axial loads
- Reliable, effective locking mechanism
- Simple installation and removal
- No keyway required<sup>1)</sup>
- Reusable
- Designed for frequent installation and removal

<sup>1)</sup> KMT and KMTA lock nuts should not be used on shafts with keyways in the thread or adapter sleeves. Damage to the locking pins can result if they align with either.

Fig. 16

KMT precision lock nut

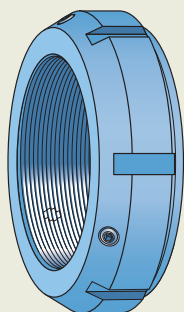

Fig. 17

KMTA precision lock nut

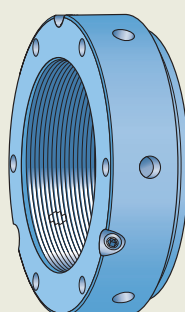
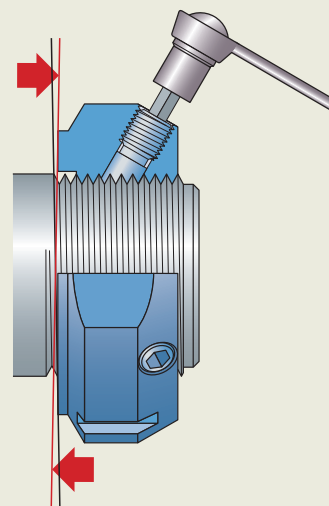

Fig. 18

Adjustable to minimise axial run-out



## The locking principle

KMT and KMTA series precision lock nuts have three locking pins equally spaced around their circumference (fig. 19 to fig. 21) that can be tightened with grub screws to lock the nut onto the shaft. The end face of each pin is machined to match the shaft thread. The holes for the locking pins and grub screws are drilled with their axis parallel to the loaded flanks of the shaft thread (fig. 22). The locking screws, when tightened to the recommended torque, provide sufficient friction between the ends of the pins and the unloaded thread flanks to prevent the nut from loosening under normal operating conditions (*Loosening torque*, page 1098). Because the locking pins are tightened against the unloaded flanks of the shaft thread, they are not subjected to any application loads imposed on the nut.

## Precision lock nuts with axial locking screws

KMD lock nuts (fig. 23) were designed specifically for screw compressors but can be used in other applications where high precision, simple assembly and reliable locking are required. Once the four locking screws are tightened, the lock nut will be accurately positioned at right angles to the shaft thread. The locking screws, when tightened to the recommended tightening torque, preload the lock nut and shaft threads and generate sufficient friction to prevent the nut from loosening under normal operating conditions. The locking screws do not carry any part of the supported load in service.

KMD lock nuts are available for thread M 20x1 to M 105x2 (sizes 4 to 21).

## Features and benefits

- Maximum axial run-out between the locating face and thread: 0,005 mm
- Adjustable for precise axial positioning
- Effective locking prevents the nut from loosening under normal operating conditions
- Simple installation and removal
- No keyway required
- Reusable
- Designed for frequent installation and removal

These lock nuts are not listed in this catalogue, but can be found online at [skf.com/go/17000-25-6](http://skf.com/go/17000-25-6).

## The locking principle

KMD lock nuts are locked with axial locking screws (fig. 24). The front of the lock nut locates the component on the shaft. The rear is tightened against the unloaded flanks of the shaft thread by axial locking screws, creating sufficient friction to prevent the lock nut from loosening under normal operating conditions.

Fig. 19

KMT lock nut with two opposed flats

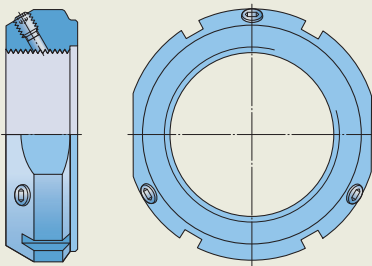

Fig. 21

KMTA lock nuts with holes around their circumference and in one side face

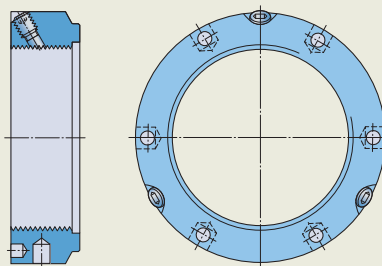

Fig. 23

KMD precision lock nut

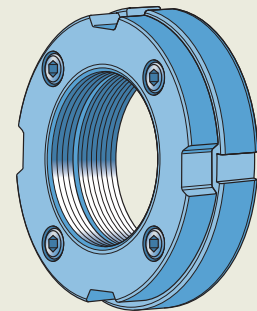

Fig. 20

KMT lock nut with six slots and no flats

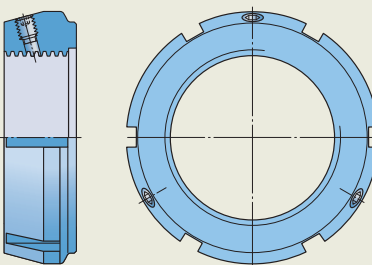

Fig. 22

Locking with locking pins

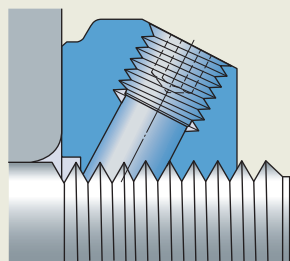
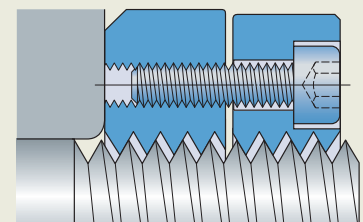

Fig. 24

Locking with axial locking screws



# Product data

	<b>Lock nuts requiring a keyway</b> KM, KML, HM .. T, HM and HME	<b>Lock nuts with integral locking</b> KMFE and KMK
<b>Dimension standards</b>	ISO 2982-2	ISO 2982-2, except for the lock nut width and the outside diameter of the clamp face  Grub screws: <ul style="list-style-type: none"> <li>• KMFE → ISO 4028, material class 45H</li> <li>• KMK → ISO 4026, material class 45H</li> </ul>
<b>Tolerances</b>	<p><b>KM and KML</b> Metric thread, 5H: ISO 965-3 Maximum axial run-out locating face/thread: 0,02 to 0,06 mm, depending on the lock nut size Mounting slots according to DIN 981</p> <p><b>HM, HME and HM .. T</b> Metric trapezoidal thread, 7H: ISO 2903 Maximum axial run-out locating face/thread: 0,06 to 0,16 mm, depending on the lock nut size</p>	Metric thread, 5H: ISO 965-3
<b>Mating shaft threads</b> (recommendation)	<p><b>KM and KML</b> Metric thread, 6g: ISO 965-3</p> <p><b>HM, HME and HM .. T</b> Metric trapezoidal thread, 7e: ISO 2903</p>	Metric thread, 6g: ISO 965-3
<b>Loosening torque</b>	–	<p>KMFE and KMK lock nuts are locked on the shaft (sleeve) by friction. The friction, and therefore the loosening torque, varies as a result of the accuracy of the tightening torque of the grub (set) screw, the surface finish of the shaft (sleeve) thread, the amount of lubricant on the thread, etc. The lock nuts should be properly mounted to threads that are dry or only have a minimum amount of lubricant on them.</p> <p>KMFE and KMK lock nuts provide sufficient locking for intended bearing applications.</p>

**Precision lock nuts with locking pins**

KMT and KMTA

Metric thread: ISO 965-3

Metric thread, 5H: ISO 965-3

Maximum axial run-out locating face/thread (sizes  $\leq 40$ ): 0,005 mm

Metric thread, 6g: ISO 965-3

Trapezoidal thread, 7e: ISO 2903

KMT and KMTA lock nuts are locked on the shaft (sleeve) by friction. The friction, and therefore the loosening torque, varies as a result of the accuracy of the tightening torque of the grub screw, the surface finish of the shaft thread, the amount of lubricant on the thread, etc. KMT and KMTA lock nuts should be properly mounted to threads that are dry or only have a minimum amount of lubricant on them.

Providing that they are properly mounted to a dry or minimally lubricated thread, experience has shown that SKF KMT and KMTA lock nuts have sufficient locking for typical super-precision and general rolling bearing applications.



# Installation and removal

## Lock nuts requiring a keyway

Lock nuts requiring a keyway are easy to install. Each nut is provided with four equally-spaced slots around their circumference to accommodate a hook or impact spanner. The designations of the associated spanners are listed in the relevant product tables.

Lock nuts requiring a keyway can be reused, provided they are not damaged. A new lock washer, locking clip or locking plate should be used each time the corresponding lock nut is reinstalled.

## Using lock nuts with lock washer to lock a bearing

### Mounting bearings and components on a cylindrical shaft

- 1 Put the bearing in place onto the cylindrical shaft.
- 2 Go ahead with step 5 below *Locking the bearing*.

### Mounting bearings on an adapter sleeve or tapered seat

- 1 Slide the bearing onto the adapter sleeve or tapered seat.
- 2 With the chamfer facing the bearing, screw the nut (without the lock washer) onto the adapter sleeve or shaft thread (fig. 25).
- 3 Tighten the nut with a hook or impact spanner until the correct clearance in the bearing is obtained (fig. 26).
- 4 Remove the nut. Go to step 5.

### Locking the bearing

- 5 Slide the lock washer onto the thread until it touches the bearing. With the chamfer facing the bearing, screw the lock nut into place (fig. 27).
- 6 Tighten the nut firmly against the lock washer and bearing with a hook or impact spanner, making sure to not over tighten the nut. For bearings on adapter sleeves or tapered shafts, make sure that the bearing is not driven up any further on its seat.
- 7 Lock the nut in place by bending one of the lock washer tabs down into one of the slots on the nut (fig. 28). Do not bend the tab to the bottom of the slot.

### Using lock nuts with locking clips to lock a bearing

- 1 With the bearing or component in position, screw the lock nut into place.
- 2 Tighten the nut against the bearing or component with an impact spanner (fig. 29), aligning one of the slots in its outside diameter with the keyway in the shaft thread and making sure to not over tighten it.
- 3 Place the spring washer and locking clip onto the attachment bolt.
- 4 Position the locking clip in the keyway in the shaft thread, and the slot in the nut outside diameter, and secure with the attachment bolt and spring washer. Align the bolt with one of the threaded holes on the side face of the lock nut.
- 5 Tighten the bolt with an appropriate wrench (fig. 30).

Fig. 25

Screw the nut, without the lock washer, onto the adapter sleeve or shaft thread

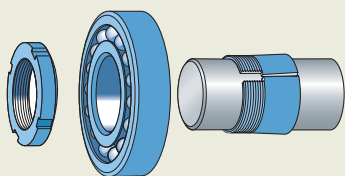

Fig. 26

Tighten the nut with a hook or impact spanner

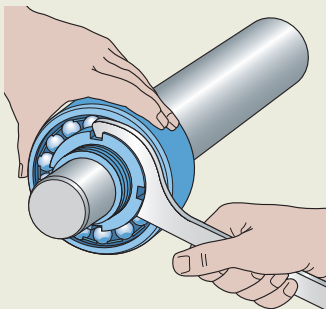
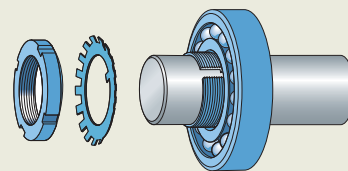

Fig. 27

Slide the lock washer onto the the thread and screw the lock nut into place



## Lock nuts with integral locking

Lock nuts with integral locking are easy to install. Each nut is provided with four equally spaced slots around its circumference to accommodate a hook spanner. The designations of the associated spanners are listed in the [product table, page 1112](#).

Lock nuts with integral locking can be reused, provided they are not damaged.

### Mounting

#### Mounting bearings on a tapered seat or special adapter sleeve

- 1 Slide the bearing onto its tapered seat.
- 2 With the contact face toward the bearing, screw the nut onto the shaft.
- 3 Tighten the nut with a hook or impact spanner, until the required internal clearance in the bearing is obtained.
- 4 Tighten the grub (set) screw to the torque value listed in the [product table](#).

Fig. 28

Lock the nut in place by bending one of the lock washer tabs down into one of the slots on the nut

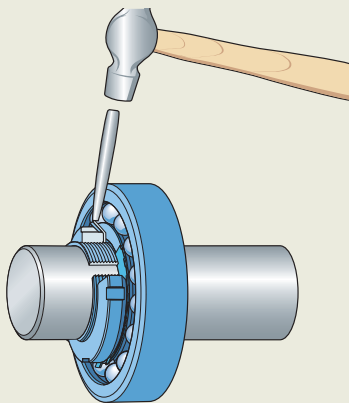

Fig. 29

Tighten the nut against the bearing or component with an impact spanner

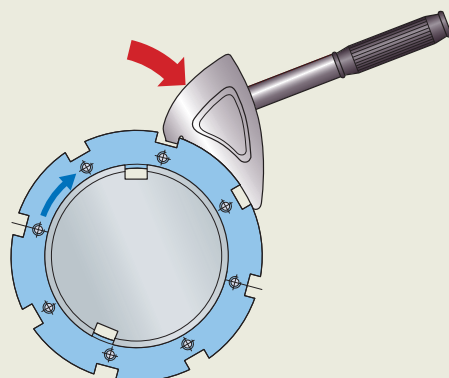
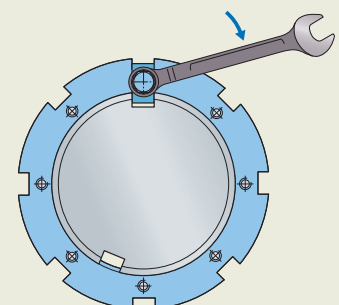

Fig. 30

Tighten the bolt with an appropriate wrench



### Locking bearings on a cylindrical seat

- 1 With the bearing in position, screw the lock nut into place.
- 2 Tighten the nut against the bearing with a hook spanner, making sure to not over-tighten it.
- 3 Tighten the grub (set) screw to the torque value listed in the [product table](#).

### Dismounting

- 1 To remove the lock nut, loosen the grub screw. Even when the grub screw is removed, the lock nut will generate a limited locking torque.
- 2 In order to completely release the locking system and facilitate the reuse of the lock nut, tap the areas near the grub screw with a hammer and soft bar. Do not damage the threaded bores for the grub screw.
- 3 Unscrew the lock nut using a hook spanner.

## Precision lock nuts with locking pins

KMT precision lock nuts have slots around their circumference to accommodate a hook or impact spanner (fig. 19, page 1097, and fig. 20, page 1097). The designations of the associated spanners are listed in the **product table, page 1114**. KMT precision lock nuts with a thread  $\leq 75$  mm (sizes  $\leq 15$ ) have additionally to the slots two opposed flats to accommodate a spanner. Those lock nuts with a thread  $\geq 80$  mm (sizes  $\geq 16$ ) have six slots and no flats.

KMTA precision lock nuts have holes around their circumference and in one side face (fig. 21, page 1097). They can be tightened with a pin wrench or a pin-type face spanner. Associated spanners in accordance with DIN 1810 are listed in the **product table, page 1116**.

Precision lock nuts with locking pins are designed for frequent installation and removal, provided they are not damaged.

### Installation

- 1 With the bearing in position, screw the lock nut into place.
- 2 Tighten the nut with a hook or impact spanner making sure not to over tighten it.
- 3 Tighten the grub screws carefully until the locking pins engage the shaft thread.
- 4 Tighten the grub screws alternately with a torque wrench until the recommended torque value, listed in the product tables, is achieved.

Precision lock nuts with locking pins should not be used to drive a bearing up onto a tapered seat.

### Adjustment

Precision lock nuts with locking pins are adjustable. The three equally-spaced locking pins enable these lock nuts to be accurately positioned at right angles to the shaft. However, they can also be adjusted to compensate for slight angular deviations of adjacent components.

Adjustments can be made using the following procedure (fig. 31 and fig. 32):

- 1 Loosen the grub screw(s) at the position showing the greatest deviation.
- 2 Tighten the remaining screw(s) equally.
- 3 Retighten the screw(s) that were loosened.
- 4 Check that the alignment of the nut, relative to the shaft, is currently as required.
- 5 Repeat the procedure if necessary.

### Removal

When removing precision lock nuts with locking pins, the locking pins can still engage the shaft thread even after the grub screws have been loosened. Using a rubber hammer, tap the nut lightly in the vicinity of the pins to loosen them.

Fig. 31

**Example 1: Adjustment procedure for KMT and KMTA lock nuts**

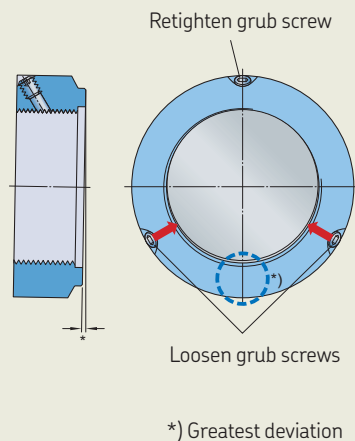
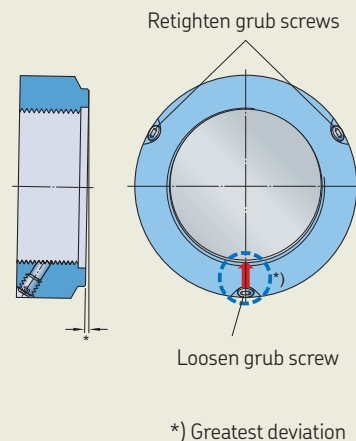

Fig. 32

**Example 2: Adjustment procedure for KMT and KMTA lock nuts**



# Designation system



## Product type

<b>AN</b>	Lock nut, dimensions in accordance with ANSI standard, normal series
<b>HM</b>	Lock nut with a trapezoidal thread
<b>HME</b>	HM lock nut with a recessed outside diameter
<b>HML</b>	HM lock nut, light series
<b>HMLL</b>	HML lock nut with a lower cross-sectional height
<b>KM</b>	Lock nut dimensions in accordance with ISO standard
<b>KMD</b>	Two-part precision lock nut with axial locking screws
<b>KMFE</b>	Lock nut with an integral locking screw, contact face designed for CARB toroidal roller bearings, sealed spherical roller bearings and sealed self-aligning ball bearings
<b>KMK</b>	Lock nut with an integral locking device
<b>KML</b>	Lock nut with a lower cross-sectional height
<b>KMT</b>	Precision lock nut with locking pins
<b>KMTA</b>	Precision lock nut with locking pins and with cylindrical outside surface (some with different thread pitch to KMT nuts)
<b>N</b>	Lock nut, dimensions in accordance with ANSI standard N lock nuts are available in two series; N 00 normal series and N 000 low profile series
<b>MB</b>	Lock washer, dimensions in accordance with ISO standard for a KM lock nut
<b>MBL</b>	Lock washer, dimensions in accordance with ISO standard for a KML lock nut
<b>MS</b>	Locking clip, dimensions in accordance with ISO standard for an HM or HME lock nut
<b>PL</b>	Locking plate, dimensions in accordance with ANSI standard
<b>W</b>	Lock washer, dimensions in accordance with ANSI standard W lock washers are available in two series; W 00 for lock nuts in normal series (AN and N) and W 000 for lock nuts in low profile series (N 0) without an axial tab

## Size identification

for metric dimensions

<b>0</b>	10 mm thread diameter
<b>1</b>	12 mm thread diameter
<b>2</b>	15 mm thread diameter
<b>3</b>	17 mm thread diameter
<b>4</b>	(x5) 20 mm thread diameter
to	to
<b>96</b>	(x5) 480 mm thread diameter
<b>/500 to</b>	500 mm thread diameter
to	to
<b>/1120</b>	1 120 mm thread diameter

for inch dimensions

<b>0</b>	0.391 in. thread diameter
<b>1</b>	0.469 in. thread diameter
<b>2</b>	0.586 in. thread diameter
<b>3</b>	0.664 in. thread diameter
<b>4</b>	0.781 in. thread diameter
to	to
<b>96</b>	18.894 in. thread diameter
<b>500</b>	19.682 in. thread diameter
to	to
<b>950</b>	37.410 in. thread diameter

## Suffixes

<b>A</b>	Increased plate thickness for MB lock washers
<b>B</b>	Whitworth thread
<b>H</b>	Bigger contact diameter
<b>L</b>	Smaller contact diameter
<b>P</b>	Sintered material
<b>T</b>	Trapezoidal thread



## 25.1 KM(L) and HM..T lock nuts

M 10x0,75 – M 200x3

Tr 210x4 – Tr 280x4

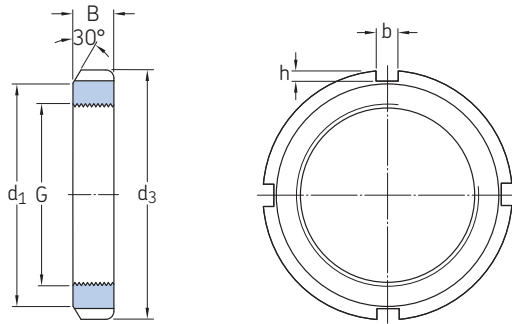

Dimensions			Axial load carrying capacity static	Mass	Designations					
G	d <sub>1</sub>	d <sub>3</sub>			Lock nut	Associated lock washer	spanner			
mm			kN	kg	–					
M 10x0,75	13,5	18	4	3	2	9,8	0,004	► KM 0	MB 0	HN 0
M 12x1	17	22	4	3	2	11,8	0,006	► KM 1	MB 1	HN 1
M 15x1	21	25	5	4	2	14,6	0,009	► KM 2	MB 2	HN 2-3
M 17x1	24	28	5	4	2	19,6	0,012	► KM 3	MB 3	HN 2-3
M 20x1	26	32	6	4	2	24	0,025	► KM 4	MB 4	HN 4
M 25x1,5	32	38	7	5	2	31,5	0,028	► KM 5	MB 5	HN 5-6
M 30x1,5	38	45	7	5	2	36,5	0,039	► KM 6	MB 6	HN 5-6
M 35x1,5	44	52	8	5	2	50	0,059	► KM 7	MB 7	HN 7
M 40x1,5	50	58	9	6	2,5	62	0,078	► KM 8	MB 8	HN 8-9
M 45x1,5	56	65	10	6	2,5	78	0,11	► KM 9	MB 9	HN 8-9
M 50x1,5	61	70	11	6	2,5	91,5	0,14	► KM 10	MB 10	HN 10-11
M 55x2	67	75	11	7	3	91,5	0,15	► KM 11	MB 11	HN 10-11
M 60x2	73	80	11	7	3	95	0,16	► KM 12	MB 12	HN 12-13
M 65x2	79	85	12	7	3	108	0,19	► KM 13	MB 13	HN 12-13
M 70x2	85	92	12	8	3,5	118	0,23	► KM 14	MB 14	HN 14
M 75x2	90	98	13	8	3,5	134	0,27	► KM 15	MB 15	HN 15
M 80x2	95	105	15	8	3,5	173	0,36	► KM 16	MB 16	HN 16
M 85x2	102	110	16	8	3,5	190	0,41	► KM 17	MB 17	HN 17
M 90x2	108	120	16	10	4	216	0,51	► KM 18	MB 18	HN 18-20
M 95x2	113	125	17	10	4	236	0,55	► KM 19	MB 19	HN 18-20
M 100x2	120	130	18	10	4	255	0,64	► KM 20	MB 20	HN 18-20
M 105x2	126	140	18	12	5	290	0,79	► KM 21	MB 21	HN 21-22
M 110x2	133	145	19	12	5	310	0,87	► KM 22	MB 22	HN 21-22

Dimensions						Axial load carrying capacity static	Mass	Designations		
G	d <sub>1</sub>	d <sub>3</sub>	B	b	h			Lock nut	Associated lock washer	spanner
mm						kN	kg	–		
<b>M 115x2</b>	137	150	19	12	5	315	0,91	▶ <b>KM 23</b>	MB 23	TMFN 23-30
<b>M 120x2</b>	135	145	20	12	5	265	0,69	▶ <b>KML 24</b>	MBL 24	HN 21-22
	138	155	20	12	5	340	0,97	▶ <b>KM 24</b>	MB 24	TMFN 23-30
<b>M 125x2</b>	148	160	21	12	5	360	1,1	▶ <b>KM 25</b>	MB 25	TMFN 23-30
<b>M 130x2</b>	145	155	21	12	5	285	0,8	▶ <b>KML 26</b>	MBL 26	TMFN 23-30
	149	165	21	12	5	365	1,1	▶ <b>KM 26</b>	MB 26	TMFN 23-30
<b>M 135x2</b>	160	175	22	14	6	430	1,4	▶ <b>KM 27</b>	MB 27	TMFN 23-30
<b>M 140x2</b>	155	165	22	12	5	305	0,92	▶ <b>KML 28</b>	MBL 28	TMFN 23-30
	160	180	22	14	6	430	1,4	▶ <b>KM 28</b>	MB 28	TMFN 23-30
<b>M 145x2</b>	171	190	24	14	6	520	1,8	▶ <b>KM 29</b>	MB 29	TMFN 23-30
<b>M 150x2</b>	170	180	24	14	5	390	1,25	▶ <b>KML 30</b>	MBL 30	TMFN 23-30
	171	195	24	14	6	530	1,9	▶ <b>KM 30</b>	MB 30	TMFN 23-30
<b>M 155x3</b>	182	200	25	16	7	540	2,1	▶ <b>KM 31</b>	MB 31	TMFN 30-40
<b>M 160x3</b>	180	190	25	14	5	405	1,4	▶ <b>KML 32</b>	MBL 32	TMFN 23-30
	182	210	25	16	7	585	2,3	▶ <b>KM 32</b>	MB 32	TMFN 30-40
<b>M 165x3</b>	193	210	26	16	7	570	2,3	▶ <b>KM 33</b>	MB 33	TMFN 30-40
<b>M 170x3</b>	190	200	26	16	5	430	1,55	▶ <b>KML 34</b>	MBL 34	TMFN 30-40
	193	220	26	16	7	620	2,35	▶ <b>KM 34</b>	MB 34	TMFN 30-40
<b>M 180x3</b>	200	210	27	16	5	450	1,8	▶ <b>KML 36</b>	MBL 36	TMFN 30-40
	203	230	27	18	8	670	2,8	▶ <b>KM 36</b>	MB 36	TMFN 30-40
<b>M 190x3</b>	210	220	28	16	5	475	1,85	▶ <b>KML 38</b>	MBL 38	TMFN 30-40
	214	240	28	18	8	695	3,05	▶ <b>KM 38</b>	MB 38	TMFN 30-40
<b>M 200x3</b>	222	240	29	18	8	625	2,6	▶ <b>KML 40</b>	MBL 40	TMFN 30-40
	226	250	29	18	8	735	3,35	▶ <b>KM 40</b>	MB 40	TMFN 30-40
<b>Tr 210x4</b>	238	270	30	20	10	Contact SKF	5,1	▶ <b>HM 42 T</b>	– <sup>1)</sup>	TMFN 40-52
<b>Tr 220x4</b>	250	280	32	20	10	Contact SKF	4,75	▶ <b>HM 44 T</b>	MB 44	TMFN 40-52
<b>Tr 230x4</b>	260	290	34	20	10	Contact SKF	5,45	<b>HM 46 T</b>	– <sup>1)</sup>	TMFN 40-52
<b>Tr 240x4</b>	270	300	34	20	10	Contact SKF	5,6	▶ <b>HM 48 T</b>	MB 48	TMFN 40-52
<b>Tr 250x4</b>	290	320	36	20	10	Contact SKF	7,45	<b>HM 50 T</b>	– <sup>1)</sup>	TMFN 40-52
<b>Tr 260x4</b>	300	330	36	24	12	Contact SKF	7,55	▶ <b>HM 52 T</b>	MB 52	TMFN 52-64
<b>Tr 280x4</b>	320	350	38	24	12	Contact SKF	8,65	▶ <b>HM 56 T</b>	MB 56	TMFN 52-64

▶ Popular item

<sup>1)</sup> HM .. T nuts having no associated lock washer are intended only for removal purposes.



## 25.2 MB(L) lock washers

### MB 0 – MB 56

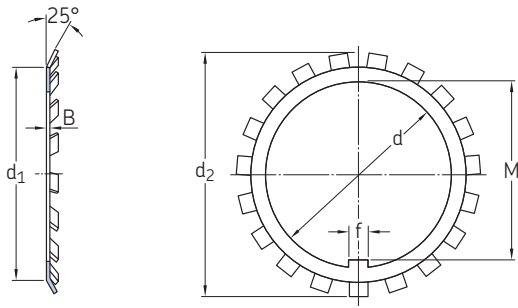

Designation	Dimensions						Mass	Designation	Dimensions						Mass
	d	d <sub>1</sub>	d <sub>2</sub>	B	f	M			d	d <sub>1</sub>	d <sub>2</sub>	B	f	M	
–	mm						kg	–	mm						kg
▶ MB 0	10	13,5	21	1	3	8,5	0,001	▶ MB 16	80	95	112	1,75	10	76,5	0,046
▶ MB 1	12	17	25	1	3	10,5	0,002	▶ MB 16 A	95	112	126	2,5	10	76,5	0,066
▶ MB 1 A		17	25	1,2	3	10,5	0,0025	▶ MB 17	85	102	119	1,75	10	81,5	0,053
▶ MB 2	15	21	28	1	4	13,5	0,003	▶ MB 17 A	102	119	126	2,5	10	81,5	0,076
▶ MB 2 A		21	28	1,2	4	13,5	0,0035	▶ MB 18	90	108	126	1,75	10	86,5	0,061
▶ MB 3	17	24	32	1	4	15,5	0,003	▶ MB 18 A	108	126	126	2,5	10	86,5	0,087
▶ MB 3 A		24	32	1,2	4	15,5	0,0035	▶ MB 19	95	113	133	1,75	10	91,5	0,066
▶ MB 4	20	26	36	1	4	18,5	0,004	▶ MB 19 A	113	133	133	2,5	10	91,5	0,094
▶ MB 4 A		26	36	1,2	4	18,5	0,005	▶ MB 20	100	120	142	1,75	12	96,5	0,077
▶ MB 5	25	32	42	1,25	5	23	0,006	▶ MB 20 A	120	142	142	2,5	12	96,5	0,11
▶ MB 5 A		32	42	1,8	5	23	0,0085	▶ MB 21	105	126	145	1,75	12	100,5	0,083
▶ MB 6	30	38	49	1,25	5	27,5	0,008	▶ MB 22	110	133	154	1,75	12	105,5	0,091
▶ MB 6 A		38	49	1,8	5	27,5	0,011	▶ MB 23	115	137	159	2	12	110,5	0,11
▶ MB 7	35	44	57	1,25	6	32,5	0,011	▶ MBL 24	120	135	152	2	14	115	0,07
▶ MB 7 A		44	57	1,8	6	32,5	0,016	▶ MB 24	138	164	164	2	14	115	0,11
▶ MB 8	40	50	62	1,25	6	37,5	0,013	▶ MB 25	125	148	170	2	14	120	0,12
▶ MB 8 A		50	62	1,8	6	37,5	0,018	▶ MBL 26	130	145	161	2	14	125	0,08
▶ MB 9	45	56	69	1,25	6	42,5	0,015	▶ MB 26	149	175	175	2	14	125	0,12
▶ MB 9 A		56	69	1,8	6	42,5	0,021	▶ MB 27	135	160	185	2	14	130	0,14
▶ MB 10	50	61	74	1,25	6	47,5	0,016	▶ MBL 28	140	155	172	2	16	135	0,09
▶ MB 10 A		61	74	1,8	6	47,5	0,023	▶ MB 28	160	192	192	2	16	135	0,14
▶ MB 11	55	67	81	1,5	8	52,5	0,022	▶ MB 29	145	172	202	2	16	140	0,17
▶ MB 11 A		67	81	2,5	8	52,5	0,037	▶ MBL 30	150	170	189	2	16	145	0,1
▶ MB 12	60	73	86	1,5	8	57,5	0,024	▶ MB 30	171	205	205	2	16	145	0,18
▶ MB 12 A		73	86	2,5	8	57,5	0,04	▶ MB 31	155	182	212	2,5	16	147,5	0,2
▶ MB 13	65	79	92	1,5	8	62,5	0,03	▶ MB 32	160	180	199	2,5	18	154	0,14
▶ MB 13 A		79	92	2,5	8	62,5	0,05	▶ MB 32	182	217	217	2,5	18	154	0,22
▶ MB 14	70	85	98	1,5	8	66,5	0,032	▶ MB 33	165	193	222	2,5	18	157,5	0,24
▶ MB 14 A		85	98	2,5	8	66,5	0,053								
▶ MB 15	75	90	104	1,5	8	71,5	0,035								
▶ MB 15 A		90	104	2,5	8	71,5	0,058								

▶ Popular item

Designation	Dimensions						Mass
	d	d <sub>1</sub>	d <sub>2</sub>	B	f	M	
–	mm						kg
▶ <b>MBL 34</b>	170	190	211	2,5	18	164	0,15
▶ <b>MB 34</b>		193	232	2,5	18	164	0,24
▶ <b>MBL 36</b>	180	200	222	2,5	20	174	0,16
▶ <b>MB 36</b>		203	242	2,5	20	174	0,26
▶ <b>MBL 38</b>	190	210	232	2,5	20	184	0,17
▶ <b>MB 38</b>		214	252	2,5	20	184	0,26
▶ <b>MBL 40</b>	200	222	245	2,5	20	194	0,22
▶ <b>MB 40</b>		226	262	2,5	20	194	0,28
▶ <b>MB 44</b>	220	250	292	3	24	213	0,35
▶ <b>MB 48</b>	240	270	312	3	24	233	0,45
▶ <b>MB 52</b>	260	300	342	3	28	253	0,65
▶ <b>MB 56</b>	280	320	362	3	28	273	0,7



## 25.3 HM lock nuts

Tr 280x4 – Tr 1120x8

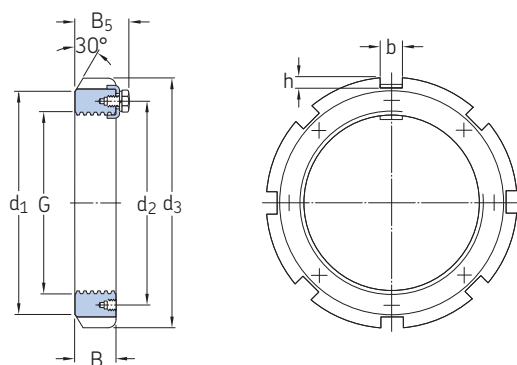

Dimensions								Mass	Designations Lock nut	Associated locking clip	spanner	eye bolt
G	d <sub>1</sub>	d <sub>2</sub>	d <sub>3</sub>	B	B <sub>5</sub>	b	h					
mm								kg	–			
<b>Tr 280x4</b>	310	293	330	38	50	24	10	5,75	▶ <b>HM 3056</b>	MS 3056	TMFN 52-64	–
<b>Tr 300x4</b>	336 340	316 326	360 380	42 40	54 53	24 24	12 12	8,35 11,5	▶ <b>HM 3060</b> ▶ <b>HM 3160</b>	MS 3060 MS 3160	TMFN 52-64 TMFN 52-64	– –
<b>Tr 320x5</b>	356 360	336 346	380 400	42 42	55 56	24 24	12 12	9 13	▶ <b>HM 3064</b> ▶ <b>HM 3164</b>	MS 3068-64 MS 3164	TMFN 52-64 TMFN 52-64	– –
<b>Tr 340x5</b>	376 400	356 373	400 440	45 55	58 72	24 28	12 15	11 24	▶ <b>HM 3068</b> ▶ <b>HM 3168</b>	MS 3068-64 MS 3172-68	TMFN 52-64 TMFN 64-80	– M 10
<b>Tr 360x5</b>	394 420	375 393	420 460	45 58	58 75	28 28	13 15	11,5 26,5	▶ <b>HM 3072</b> ▶ <b>HM 3172</b>	MS 3072 MS 3172-68	TMFN 64-80 TMFN 64-80	– M 10
<b>Tr 380x5</b>	422 440	399 415	450 490	48 60	62 77	28 32	14 18	15 32	▶ <b>HM 3076</b> ▶ <b>HM 3176</b>	MS 3080-76 MS 3176	TMFN 64-80 TMFN 64-80	– M 10
<b>Tr 400x5</b>	442 460	419 440	470 520	52 62	66 82	28 32	14 18	17 38	▶ <b>HM 3080</b> ▶ <b>HM 3180</b>	MS 3080-76 MS 3184-80	TMFN 64-80 TMFN 64-80	– M 10
<b>Tr 420x5</b>	462 490	439 460	490 540	52 70	66 90	32 32	14 18	18,5 45	▶ <b>HM 3084</b> ▶ <b>HM 3184</b>	MS 3084 MS 3184-80	TMFN 64-80 TMFN 80-500	– M 10
<b>Tr 440x5</b>	490 510	463 478	520 560	60 70	77 90	32 36	15 20	26 46,5	▶ <b>HM 3088</b> ▶ <b>HM 3188</b>	MS 3092-88 MS 3192-88	TMFN 64-80 TMFN 80-500	M 10 M 10
<b>Tr 460x5</b>	510 540	483 498	540 580	60 75	77 95	32 36	15 20	27 50,5	▶ <b>HM 3092</b> <b>HM 3192</b>	MS 3092-88 MS 3192-88	TMFN 80-500 TMFN 80-500	M 10 M 10
<b>Tr 480x5</b>	560	528	620	75	95	36	20	62	<b>HM 3196</b>	MS 3196	TMFN 80-500	M 10
<b>Tr 500x5</b>	550	523	580	68	85	36	15	33,5	▶ <b>HM 30/500</b>	MS 30/500-96	TMFN 500-600	M 10
<b>Tr 530x6</b>	590	558	630	68	90	40	20	42,5	▶ <b>HM 30/530</b>	MS 30/600-530	TMFN 500-600	M 10
<b>Tr 560x6</b>	610	583	650	75	97	40	20	44,5	▶ <b>HM 30/560</b>	MS 30/560	TMFN 500-600	M 10
<b>Tr 600x6</b>	660	628	700	75	97	40	20	52,5	▶ <b>HM 30/600</b>	MS 30/600-530	TMFN 500-600	M 10
<b>Tr 630x6</b>	690	658	730	75	97	45	20	55	▶ <b>HM 30/630</b>	MS 30/630	TMFN 500-600	M 10
<b>Tr 670x6</b>	740	703	780	80	102	45	20	68,5	▶ <b>HM 30/670</b>	MS 30/670	TMFN 600-750	M 10
<b>Tr 710x7</b>	780	742	830	90	112	50	25	91,5	▶ <b>HM 30/710</b>	MS 30/710	TMFN 600-750	M 12
<b>Tr 750x7</b>	820	782	870	90	112	55	25	94	▶ <b>HM 30/750</b>	MS 30/800-750	TMFN 600-750	M 12

▶ Popular item



Dimensions								Mass	Designations Lock nut	Associated locking clip	spanner	eye bolt
G	d <sub>1</sub>	d <sub>2</sub>	d <sub>3</sub>	B	B <sub>5</sub>	b	h					
mm								kg	–			
<b>Tr 800x7</b>	870	832	920	90	112	55	25	99,5	▶ <b>HM 30/800</b>	MS 30/800-750	TMFN 600-750	M 12
<b>Tr 850x7</b>	925	887	980	90	115	60	25	115	▶ <b>HM 30/850</b>	MS 30/900-850	–	M 12
<b>Tr 900x7</b>	975	937	1 030	100	125	60	25	131	▶ <b>HM 30/900</b>	MS 30/900-850	–	M 16
<b>Tr 950x8</b>	1 025	985	1 080	100	125	60	25	139	▶ <b>HM 30/950</b>	MS 30/950	–	M 16
<b>Tr 1000x8</b>	1 085	1 040	1 140	100	125	60	25	157	▶ <b>HM 30/1000</b>	MS 30/1000	–	M 16
<b>Tr 1060x8</b>	1 145	1 100	1 200	100	125	60	25	166	▶ <b>HM 30/1060</b>	MS 30/1000	–	M 16
<b>Tr 1120x8</b>	1 205	1 160	1 260	100	125	60	25	175	▶ <b>HM 30/1120</b>	MS 30/1000	–	M 16

▶ Popular item



## 25.4 MS locking clips

### MS 3044 – MS 31/1000

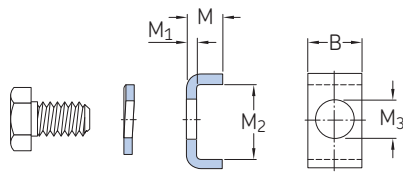

Designations Locking clip	Included hexagonal head bolt	spring washer in accordance with DIN 128	Dimensions					Mass
			B	M	M <sub>1</sub>	M <sub>2</sub>	M <sub>3</sub>	
–			mm					kg
▶ MS 3044	M 6x12	A 6	20	12	4	13,5	7	0,022
▶ MS 3052-48	M 8x16	A 8	20	12	4	17,5	9	0,024
▶ MS 3056	M 8x16	A 8	24	12	4	17,5	9	0,03
▶ MS 3060	M 8x16	A 8	24	12	4	20,5	9	0,033
▶ MS 3068-64	M 8x16	A 8	24	15	5	21	9	0,046
▶ MS 3072	M 8x16	A 8	28	15	5	20	9	0,051
▶ MS 3080-76	M 10x20	A 10	28	15	5	24	12	0,055
▶ MS 3084	M 10x20	A 10	32	15	5	24	12	0,063
▶ MS 3092-88	M 12x25	A 12	32	15	5	28	14	0,067
▶ MS 30/500-96	M 12x25	A 12	36	15	5	28	14	0,076
▶ MS 30/560	M 16x30	A 16	40	21	7	29	18	0,15
▶ MS 30/600-530	M 16x30	A 16	40	21	7	34	18	0,14
▶ MS 30/630	M 16x30	A 16	45	21	7	34	18	0,17
MS 30/670	M 16x30	A 16	45	21	7	39	18	0,19
MS 30/710	M 16x30	A 16	50	21	7	39	18	0,21
MS 30/800-750	M 16x30	A 16	55	21	7	39	18	0,23
MS 30/900-850	M 20x40	A 20	60	21	7	44	22	0,26
MS 30/950	M 20x40	A 20	60	21	7	46	22	0,26
MS 30/1000	M 20x40	A 20	60	21	7	51	22	0,28
▶ MS 3160	M 10x20	A 10	24	12	4	30,5	12	0,04
▶ MS 3164	M 10x20	A 10	24	15	5	31	12	0,055
▶ MS 3172-68	M 12x25	A 12	28	15	5	38	14	0,069
MS 3176	M 12x25	A 12	32	15	5	40	14	0,083
▶ MS 3184-80	M 16x30	A 16	32	15	5	45	18	0,089

▶ Popular item

Designations Locking clip	Included hexagonal head bolt	spring washer in accordance with DIN 128	Dimensions					Mass
			B	M	M <sub>1</sub>	M <sub>2</sub>	M <sub>3</sub>	
–			mm					kg
▶ MS 3192-88	M 16x30	A 16	36	15	5	43	18	0,097
MS 3196	M 16x30	A 16	36	15	5	53	18	0,11
MS 31/500	M 16x30	A 16	40	15	5	45	18	0,11
MS 31/530	M 20x40	A 20	40	21	7	51	22	0,19
MS 31/600-560	M 20x40	A 20	45	21	7	54	22	0,22
MS 31/630	M 20x40	A 20	50	21	7	61	22	0,27
MS 31/670	M 20x40	A 20	50	21	7	66	22	0,28
MS 31/710	M 24x50	A 24	55	21	7	69	26	0,32
MS 31/800-750	M 24x50	A 24	60	21	7	70	26	0,35
MS 31/850	M 24x50	A 24	70	21	7	71	26	0,41
MS 31/900	M 24x50	A 24	70	21	7	76	26	0,41
MS 31/950	M 24x50	A 24	70	21	7	78	26	0,42
MS 31/1000	M 24x50	A 24	70	21	7	88	26	0,5





## 25.5 KMFE lock nuts with a locking screw

### M 20x1 – M 200x3

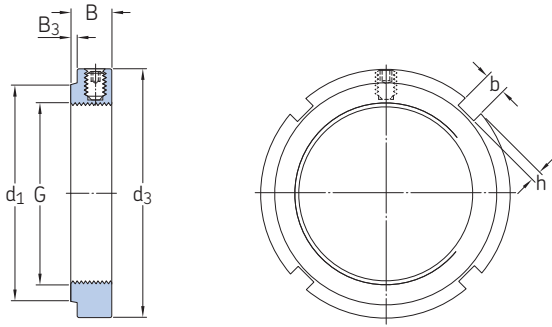

Dimensions							Axial load carrying capacity static	Mass	Designations		Grub (set) screw	
G	d <sub>1</sub>	d <sub>3</sub>	B	B <sub>3</sub>	b	h			Lock nut	Associated spanner	Size	Recommended tightening torque
mm							kN	kg	–		–	Nm
M 20x1	26	32	9,5	1	4	2	24	0,034	► KMFE 4	HN 4	M5	4,5
M 25x1,5	31	38	10,5	2	5	2	31,5	0,049	► KMFE 5	HN 5-6	M5	4,5
M 30x1,5	36	45	10,5	2	5	2	36,5	0,066	► KMFE 6	HN 5-6	M5	4,5
M 35x1,5	42,5	52	11,5	3	5	2	50	0,092	► KMFE 7	HN 7	M5	4,5
M 40x1,5	47	58	13	3	6	2,5	62	0,12	► KMFE 8	HN 8-9	M6	8
M 45x1,5	53	65	13	3	6	2,5	78	0,15	► KMFE 9	HN 8-9	M6	8
M 50x1,5	57,5	70	14	3	6	2,5	91,5	0,18	► KMFE 10	HN 10-11	M6	8
M 55x2	64	75	14	3	7	3	91,5	0,21	► KMFE 11	HN 10-11	M6	8
M 60x2	69	80	14	3	7	3	95	0,22	► KMFE 12	HN 12-13	M6	8
M 65x2	76	85	15	3	7	3	108	0,26	► KMFE 13	HN 12-13	M6	8
M 70x2	79	92	15	3	8	3,5	118	0,3	► KMFE 14	HN 14	M6	8
M 75x2	84	98	16	3	8	3,5	134	0,36	► KMFE 15	HN 15	M6	8
M 80x2	91,5	105	18	3	8	3,5	173	0,48	► KMFE 16	HN 16	M8	18
M 85x2	98	110	19	4	8	3,5	190	0,53	► KMFE 17	HN 17	M8	18
M 90x2	102	120	19	4	10	4	216	0,66	► KMFE 18	HN 18-20	M8	18
M 95x2	110	125	20	4	10	4	236	0,75	► KMFE 19	HN 18-20	M8	18
M 100x2	112	130	21	4	10	4	255	0,81	► KMFE 20	HN 18-20	M8	18
M 110x2	121	145	21,5	4	12	5	310	1,05	► KMFE 22	HN 21-22	M8	18
M 120x2	130	155	26	6	12	5	340	1,3	► KMFE 24	TMFN 23-30	M10	35
M 130x2	141	165	28	7	12	5	365	1,5	► KMFE 26	TMFN 23-30	M10	35
M 140x2	152	180	28	7	14	6	440	1,85	► KMFE 28	TMFN 23-30	M10	35
M 150x2	162	195	30	9	14	6	495	2,25	► KMFE 30	TMFN 23-30	M10	35
M 160x3	173	210	32	11	16	7	540	2,8	► KMFE 32	TMFN 30-40	M10	35

Dimensions							Axial load carrying capacity static	Mass	Designations		Grub (set) screw	
G	d <sub>1</sub>	d <sub>3</sub>	B	B <sub>3</sub>	b	h			Lock nut	Associated spanner	Size	Recommended tightening torque
mm							kN	kg	–		–	Nm
<b>M 170x3</b>	184	220	33	12	16	7	550	3	▶ <b>KMFE 34</b>	TMFN 30-40	M10	35
<b>M 180x3</b>	194	230	34	12	18	8	590	3,3	▶ <b>KMFE 36</b>	TMFN 30-40	M10	35
<b>M 190x3</b>	207	240	34	12	18	8	610	3,55	▶ <b>KMFE 38</b>	TMFN 30-40	M10	35
<b>M 200x3</b>	217	250	34	12	18	8	625	3,7	▶ <b>KMFE 40</b>	TMFN 30-40	M10	35

▶ Popular item



## 25.6 KMT precision lock nuts with locking pins

### M 10x0,75 – M 200x3

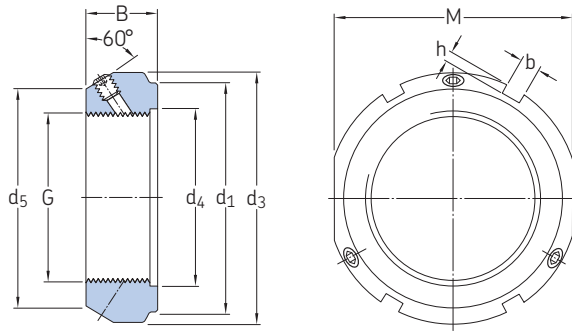

Dimensions						Axial load carrying capacity static	Mass kg	Designations		Grub (set) screw Size	Recommended tightening torque Nm			
G	d <sub>1</sub>	d <sub>3</sub>	d <sub>4</sub>	d <sub>5</sub>	B			M	b			h	Lock nut	Associated spanner
mm						kN	kg	–		–	Nm			
M 10x0,75	23	28	11	21	14	24	4	2	35	0,045	▶ KMT 0	HN 2-3	M 5	4,5
M 12x1	25	30	13	23	14	27	4	2	40	0,05	▶ KMT 1	HN 4	M 5	4,5
M 15x1	28	33	16	26	16	30	4	2	60	0,075	▶ KMT 2	HN 4	M 5	4,5
M 17x1	33	37	18	29	18	34	5	2	80	0,1	▶ KMT 3	HN 5-6	M 6	8
M 20x1	35	40	21	32	18	36	5	2	90	0,11	▶ KMT 4	HN 5-6	M 6	8
M 25x1,5	39	44	26	36	20	41	5	2	130	0,13	▶ KMT 5	HN 5-6	M 6	8
M 30x1,5	44	49	32	41	20	46	5	2	160	0,16	▶ KMT 6	HN 7	M 6	8
M 35x1,5	49	54	38	46	22	50	5	2	190	0,19	▶ KMT 7	HN 7	M 6	8
M 40x1,5	59	65	42	54	22	60	6	2,5	210	0,3	▶ KMT 8	HN 8-9	M 8	18
M 45x1,5	64	70	48	60	22	65	6	2,5	240	0,33	▶ KMT 9	HN 10-11	M 8	18
M 50x1,5	68	75	52	64	25	70	7	3	300	0,4	▶ KMT 10	HN 10-11	M 8	18
M 55x2	78	85	58	74	25	80	7	3	340	0,54	▶ KMT 11	HN 12-13	M 8	18
M 60x2	82	90	62	78	26	85	8	3,5	380	0,61	▶ KMT 12	HN 12-13	M 8	18
M 65x2	87	95	68	83	28	90	8	3,5	460	0,71	▶ KMT 13	HN 15	M 8	18
M 70x2	92	100	72	88	28	95	8	3,5	490	0,75	▶ KMT 14	HN 15	M 8	18
M 75x2	97	105	77	93	28	100	8	3,5	520	0,8	▶ KMT 15	HN 16	M 8	18
M 80x2	100	110	83	98	32	–	8	3,5	620	0,9	▶ KMT 16	HN 17	M 8	18
M 85x2	110	120	88	107	32	–	10	4	650	1,15	▶ KMT 17	HN 18-20	M 10	35
M 90x2	115	125	93	112	32	–	10	4	680	1,2	▶ KMT 18	HN 18-20	M 10	35
M 95x2	120	130	98	117	32	–	10	4	710	1,25	▶ KMT 19	HN 18-20	M 10	35
M 100x2	125	135	103	122	32	–	10	4	740	1,3	▶ KMT 20	HN 21-22	M 10	35
M 110x2	134	145	112	132	32	–	10	4	800	1,45	▶ KMT 22	HN 21-22	M 10	35

Dimensions									Axial load carrying capacity static	Mass	Designations		Grub (set) screw	
G	d <sub>1</sub>	d <sub>3</sub>	d <sub>4</sub>	d <sub>5</sub>	B	M	b	h			Lock nut	Associated spanner	Size	Recommended tightening torque
mm									kN	kg	–		–	Nm
<b>M 120x2</b>	144	155	122	142	32	–	10	4	860	1,6	▶ <b>KMT 24</b>	HN 21-22	M 10	35
<b>M 130x2</b>	154	165	132	152	32	–	12	5	920	1,7	▶ <b>KMT 26</b>	TMFN 23-30	M 10	35
<b>M 140x2</b>	164	175	142	162	32	–	14	5	980	1,8	▶ <b>KMT 28</b>	TMFN 23-30	M 10	35
<b>M 150x2</b>	174	185	152	172	32	–	14	5	1 040	1,95	▶ <b>KMT 30</b>	TMFN 23-30	M 10	35
<b>M 160x3</b>	184	195	162	182	32	–	14	5	1 100	2,1	▶ <b>KMT 32</b>	TMFN 23-30	M 10	35
<b>M 170x3</b>	192	205	172	192	32	–	14	5	1 160	2,2	▶ <b>KMT 34</b>	TMFN 30-40	M 10	35
<b>M 180x3</b>	204	215	182	202	32	–	16	5	1 220	2,3	▶ <b>KMT 36</b>	TMFN 30-40	M 10	35
<b>M 190x3</b>	214	225	192	212	32	–	16	5	1 280	2,4	▶ <b>KMT 38</b>	TMFN 30-40	M 10	35
<b>M 200x3</b>	224	235	202	222	32	–	18	5	1 340	2,5	▶ <b>KMT 40</b>	TMFN 30-40	M 10	35

▶ Popular item



## 25.7 KMTA precision lock nuts with locking pins

### M 25x1,5 – M 200x3

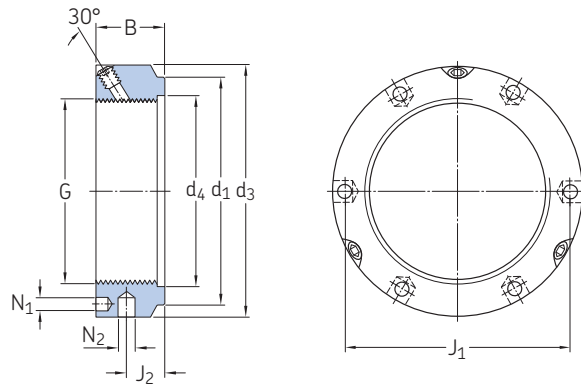

Dimensions					Axial load carrying capacity static	Mass	Designations		Grub (set) screw Size	Recommended tightening torque				
G	d <sub>1</sub>	d <sub>3</sub>	d <sub>4</sub>	B			J <sub>1</sub>	J <sub>2</sub>			Lock nut	Associated spanner		
mm					kN	kg	-		-	Nm				
M 25x1,5	35	42	26	20	32,5	11	4,3	4	130	0,13	► KMTA 5	B 40-42	M 6	8
M 30x1,5	40	48	32	20	40,5	11	4,3	5	160	0,16	► KMTA 6	B 45-50	M 6	8
M 35x1,5	47	53	38	20	45,5	11	4,3	5	190	0,19	► KMTA 7	B 52-55	M 6	8
M 40x1,5	52	58	42	22	50,5	12	4,3	5	210	0,23	► KMTA 8	B 58-62	M 6	8
M 45x1,5	58	68	48	22	58	12	4,3	6	240	0,33	► KMTA 9	B 68-75	M 6	8
M 50x1,5	63	70	52	24	61,5	13	4,3	6	300	0,34	► KMTA 10	B 68-75	M 6	8
M 55x1,5	70	75	58	24	66,5	13	4,3	6	340	0,37	► KMTA 11	B 68-75	M 6	8
M 60x1,5	75	84	62	24	74,5	13	5,3	6	380	0,49	► KMTA 12	B 80-90	M 8	18
M 65x1,5	80	88	68	25	78,5	13	5,3	6	460	0,52	► KMTA 13	B 80-90	M 8	18
M 70x1,5	86	95	72	26	85	14	5,3	8	490	0,62	► KMTA 14	B 95-100	M 8	18
M 75x1,5	91	100	77	26	88	13	6,4	8	520	0,66	► KMTA 15	B 95-100	M 8	18
M 80x2	97	110	83	30	95	16	6,4	8	620	1	► KMTA 16	B 110-115	M 8	18
M 85x2	102	115	88	32	100	17	6,4	8	650	1,15	► KMTA 17	B 110-115	M 10	35
M 90x2	110	120	93	32	108	17	6,4	8	680	1,2	► KMTA 18	B 120-130	M 10	35
M 95x2	114	125	98	32	113	17	6,4	8	710	1,25	► KMTA 19	B 120-130	M 10	35
M 100x2	120	130	103	32	118	17	6,4	8	740	1,3	► KMTA 20	B 120-130	M 10	35
M 110x2	132	140	112	32	128	17	6,4	8	800	1,45	► KMTA 22	B 135-145	M 10	35
M 120x2	142	155	122	32	140	17	6,4	8	860	1,85	► KMTA 24	B 155-165	M 10	35
M 130x3	156	165	132	32	153	17	6,4	8	920	2	► KMTA 26	B 155-165	M 10	35
M 140x3	166	180	142	32	165	17	6,4	10	980	2,45	► KMTA 28	B 180-195	M 10	35
M 150x3	180	190	152	32	175	17	6,4	10	1 040	2,6	► KMTA 30	B 180-195	M 10	35
M 160x3	190	205	162	32	185	17	8,4	10	1 100	3,15	► KMTA 32	B 205-220	M 10	35

Dimensions									Axial load carrying capacity static	Mass	Designations		Grub (set) screw	
G	d <sub>1</sub>	d <sub>3</sub>	d <sub>4</sub>	B	J <sub>1</sub>	J <sub>2</sub>	N <sub>1</sub>	N <sub>2</sub>			Lock nut	Associated spanner	Size	Recommended tightening torque
mm									kN	kg	–		–	Nm
<b>M 170x3</b>	205	215	172	32	195	17	8,4	10	1 160	3,3	▶ <b>KMTA 34</b>	B 205-220	M 10	35
<b>M 180x3</b>	215	230	182	32	210	17	8,4	10	1 220	3,9	▶ <b>KMTA 36</b>	B 230-245	M 10	35
<b>M 190x3</b>	225	240	192	32	224	17	8,4	10	1 280	4,1	▶ <b>KMTA 38</b>	B 230-245	M 10	35
<b>M 200x3</b>	237	245	202	32	229	17	8,4	10	1 340	3,85	▶ <b>KMTA 40</b>	B 230-245	M 10	35

