

# Gravity Conveyors



Gravity roller conveyors provide essential material handling free moving, efficient and safe transportation of goods at any operational stage of a conveyor line on a daily basis.

Gravity roller conveyors are an economical solution ideal for moving heavy and non standard shaped items along processing and packaging lines. Providing flexibility with innovative interlocking sections supplied as standard in 1.5 and 3m sections allowing for addition and subtraction of a conveyor line as required. Richmond Gravity Conveyors have been designed with thicker channeling, stronger cross members and a high quality powder coated finish for hard wearing and maximum rigidity over the full length of any hard working conveyor line.

It is recommended that there be a minimum of three rollers under the goods to be transported at any one time. The size of the object being transported can help determine the roller pitch on your conveyor system applying the three roller rule.

We can custom manufacture gravity conveyor systems to suit your length, width, pitch and roller requirement.

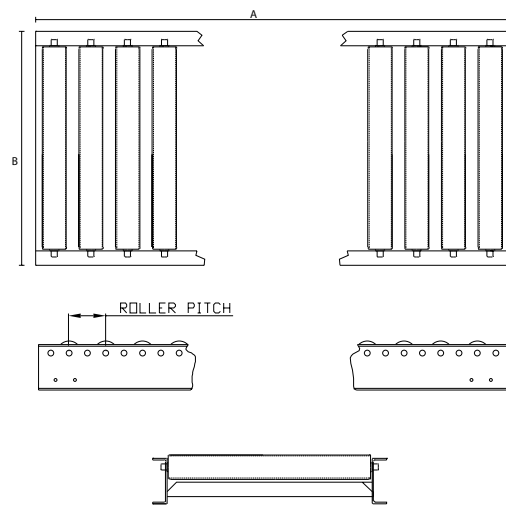

**ROLLER SITS ABOVE CHANNEL  
STEEL ROLLER 50MM DIAMETER  
NYLON ROLLER 48MM DIAMETER**

## Specifications

Model Number	Length (mm) (A)	Pitch (mm)	Overall Width (mm) (B)	Number of Rollers	Roller Material
CGR070	1500	75	290	20	Steel
CGR071	1500	75	290	20	Nylon
CGR069	1500	115	290	13	Steel
CGR072	1500	115	290	13	Nylon
CGR073	1500	150	290	10	Steel
CGR074	1500	150	290	10	Nylon
CGR075	3000	75	290	40	Steel
CGR076	3000	75	290	40	Nylon
CGR077	3000	115	290	26	Steel
CGR078	3000	115	290	26	Nylon
CGR079	3000	150	290	20	Steel
CGR080	3000	150	290	20	Nylon
CGR081	1500	75	450	20	Steel
CGR082	1500	75	450	20	Nylon
CGR083	1500	115	450	13	Steel
CGR084	1500	115	450	13	Nylon
CGR085	1500	150	450	10	Steel
CGR086	1500	150	450	10	Nylon
CGR087	3000	75	450	40	Steel
CGR088	3000	75	450	40	Nylon
CGR089	3000	115	450	26	Steel
CGR090	3000	115	450	26	Nylon
CGR091	3000	150	450	20	Steel
CGR068	3000	150	450	20	Nylon
CGR092	1500	75	600	20	Steel
CGR093	1500	75	600	20	Nylon
CGR094	1500	115	600	13	Steel
CGR095	1500	115	600	13	Nylon
CGR096	1500	150	600	10	Steel
CGR097	1500	150	600	10	Nylon
CGR098	3000	75	600	40	Steel
CGR099	3000	75	600	40	Nylon
CGR100	3000	115	600	26	Steel
CGR101	3000	115	600	26	Nylon
CGR102	3000	150	600	20	Steel
CGR103	3000	150	600	20	Nylon