

WP-270Series

For models WP-270S and WP-270SH



HORIZONTAL METAL CUTTING BAND SAW

*Study Carefully Before Operating

WP-270S

WP-270SH

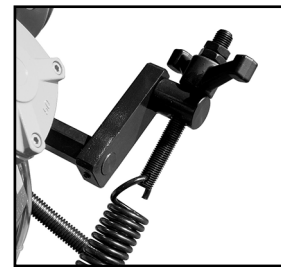
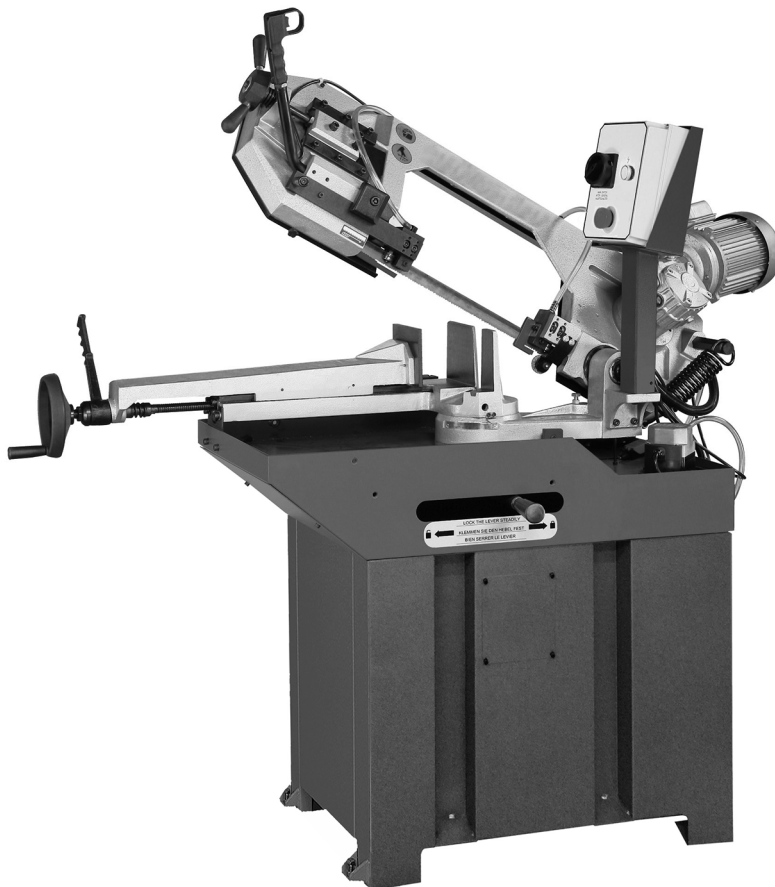

Specifications

Capacity:



90°	220mm (8.6")	215mm (8.4")	110x260mm (4.3"x10.2")
45°	150mm (5.9")	145mm (5.7")	110x155mm (4.3"x6.1")
60°	90mm (3.5")	85mm (3.3")	80x95mm (3.1"x3.7")

Blade Size

27x0.9x2460mm

Blade Speed

50Hz 4P 72m/min 8P 36m/min

Motor

1.1kW (1.5HP)

Packing size (L xWxH)

1549x737x1054mm

Container Loads

22 units / 20' 46 units / 40'

NW: 216kgs GW: 250kgs

Contents

Chapter 1

ACCIDENT PREVENTION AND SAFETY REGULATION

1.1 Advice for the Operator	2
1.2 The Electrical Equipment According to European Standard" CENELEC EN 60204-1"	2
1.3 Emergencies According to European Standard "CENELEC EN 60204-1"	2

Chapter 2

MACHINE DIMENSIONS TRANSPORT INSTALLATION DISMANTLING

2.1 Machine Dimensions	2
2.2 Transportation of Your Machine	2
2.3 Minimum Requirements for Housing the Machine	3
2.4 Position the Machine	3
2.5 Instructions for Assembly of the Loose Parts and Accessories	3
2.6 Deactivation of Machine	3
2.7 Dismantling	3

Chapter 3

THE MACHINE'S FUNCTIONAL PARTS

3.1 The Saw Bow	3
3.2 Controls	3
3.3 Vise Adjustment	4
3.4 Cutting Angle Adjustment	4
3.5 The Base	4

Chapter 4

OPERATING AND ADVICE ON USING YOUR BANDSAW

4.1 The Operation Cycle	4
4.2 Recommendations for Using the Machine	5

Chapter 5

ADJUSTING YOUR MACHINE

5.1 Blade Tension Assembly	6
5.2 Aligning the Flywheel	6
5.3 Checking the Adjustment of the Blade	6
5.4 Adjusting the Blade Guide	7
5.5 Changing the Blade	7

Chapter 6

ROUTINE AND SPECIAL MAINTENANCE

6.1 Daily Maintenance	8
6.2 Weekly Maintenance	8
6.3 Monthly Maintenance	8
6.4 Six-monthly Maintenance	8
6.5 Oils for Lubricating Coolant	8
6.6 Oil Disposal	8
6.7 Coolant System	8
6.8 The Gearbox	8
6.9 Special Maintenance	8

Chapter 7

TECHNICAL CHARACTERISTICS

7.1 Table of Cutting Capacity and Technical Details	9
--	---

Chapter 8

MATERIAL CLASSIFICATION AND CHOICE OF TOOL

8.1 Definition of Materials	9
8.2 Selecting Blade	9
8.3 Teeth Pitch	10
8.4 Cutting and Advance Speed	10
8.5 Blade Running-in	10
8.6 Blade Structure	10
8.7 Blade Type	10

Chapter 9

NOISE TESTS	11
-------------------	----

Chapter 10

WIRING DIAGRAM	12
----------------------	----

Chapter 11

TROUBLESHOOTING

11.1 - Blade and Cut Diagnosis	14
--------------------------------------	----

Chapter 12

MACHINE COMPONENTS

12.1 Parts List	18
12.2 Explosion Drawings	20

1 ACCIDENT PREVENTION AND SAFETY REGULATION

This machine has been designed to comply with national and community accident-prevention regulations. Improper use and/or tampering with the safety devices will relieve the manufacturer of all responsibility.

1.1 Advice for the Operator

- Check that the voltage indicated on machine motor is the same as the line voltage.
- Check the efficiency of your electric supply and grounding system; connect the power cable of the machine to the socket and the ground lead (yellow-green in color) to the grounding system.
- When the saw frame is in suspended mode (or raised) the blade must not move.
- Only the blade section used for cutting must be kept unprotected. To adjust the blade guards use on the blade guides.
- It is forbidden to use the machine without its shields
- Always disconnect the machine from the power socket before blade change or carrying out any maintenance job, even in the case of abnormal machine operation.
- Always wear suitable eyes protection.
- Never put your hands or arms into the cutting area while the machine is operating.
- Do not shift the machine while it is cutting.
- Do not wear loose clothing like: shirts with sleeves that are too long, gloves that are too big, bracelets, chains or any other object that could get caught in the machine during operation. Tie back long hair.
- Keep the area free of equipment, tools, or any other object.
- Perform only one operation at a time. Never have several objects in your hands at the same time. Keep your hands as clean as possible.
- All internal operations, maintenance or repairs, must be performed in a well-lit area or where there is sufficient light from extra sources so as to avoid the risk of even slight accidents

1.2 The electrical equipment according to European Standard" CENELEC EN 60204-1"

- The electrical equipment ensures protection against electric shock as a result of direct or indirect contact. The active parts of this equipment are housed in a box to which access is limited by screws that can only be removed with a special tool; the parts are fed with alternating current as low voltage (24V). The equipment is protected against splashes of water and dust.
- Protection of the system against short circuits is ensured by means of rapid fuses and grounding; in the event of a motor overload, protection is provided by a thermal probe.
- In the event of a power cut, the specific start-up button must be reset.
- The machine has been tested in conformity with point 20 of EN 60204

1.3 Emergencies according to European Standard "CENELEC EN 60204-1"

- In the event of incorrect operation or of danger conditions, the machine may be stopped immediately by pressing the red mushroom button.
- The casual or voluntary removal of the protection shield of the flywheels causes the stepping-in of a micro-switch that automatically stops all machine functions.

2 MACHINE DIMENSIONS TRANSPORT INSTALLATION DISMANTLING

2.1 Machine Dimensions

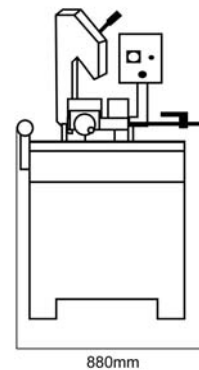
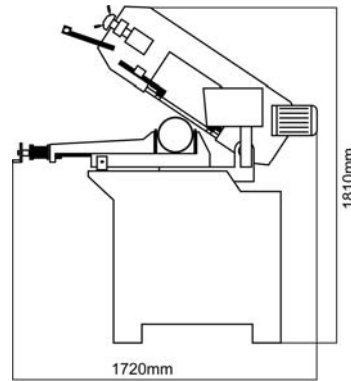

2.2 Transportation of Your Machine

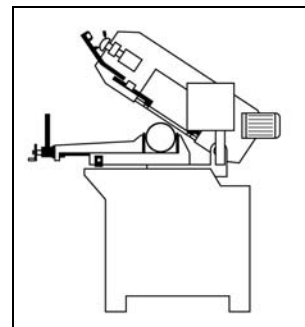

To move the machine, the machine needs to be moved in its own packing, use a forklift truck to move it.

2.3 Minimum Requirements for Housing the Machine

- Main voltage and frequency must comply with the machine's motor requirements.
- Environment temperature should fall within -10 °C to +50 °C.
- Relative humidity cannot be over 90%.

2.4 Position the Machine

Position the machine on a firm cement floor, maintaining, at the rear, a minimum distance of 800 mm from the wall; ensuring it is sitting on level.

2.5 Instructions for Assembly of the Loose Parts and Accessories

Fit the components supplied:

Detail 1 Mount bar-stop rod

Detail 2 Mount and align the roll-supporting arm as per the vise table.

2.6 Deactivation of Machine

- If the sawing machine is to be out of use for a long period, it is advisable to proceed as follows:
 - 1) Detach the plug from the electric supply panel
 - 2) Loosen blade
 - 3) Release the saw bow's counter-balance spring
 - 4) Empty the coolant tank
 - 5) Carefully clean and grease the machine
 - 6) If necessary, cover the machine.

2.7 Dismantling (due to deterioration and/or obsolescence)

General rules

If the machine is to be permanently demolished and/or scrapped, divide the material to be disposed of according to type and composition, as follows:

- 1) Non-composite cast iron or ferrous materials are recyclable raw materials, so they may be taken to an iron foundry for re-smelting after having removed the contents (classified in point 3).
- 2) Electrical components, including the cable and electronic material (magnetic cards, etc.), fall within the category of material classified as being assimilated to urban waste according to the laws of your local, state, or federal government, so they may be set aside for collection by the public waste disposal service;
- 3) Old mineral and synthetic and/or mixed oils, emulsified oils and greases are considered hazardous or special refuse, so they must be collected, transported and disposed of at a special waste disposal service.

NOTE: The standards and legislation concerning refuse is in a constant state of evolution, therefore is subject to changes. The user must keep informed of the regulations at the time of disposal as these may differ from those described above.

3 THE MACHINE'S FUNCTIONAL PARTS

3.1 The Saw Bow

The saw bow is a collection of machine parts consisting of a saw bow, drive members (gears transfer, motor, blade wheel), blade tension system, blade guides, and blade guards. The WP-270SH model also includes a hydraulic cylinder and adjustable counter-balance spring.

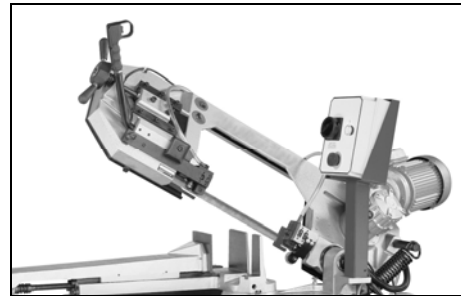

3.2 Controls

For model WP-270S

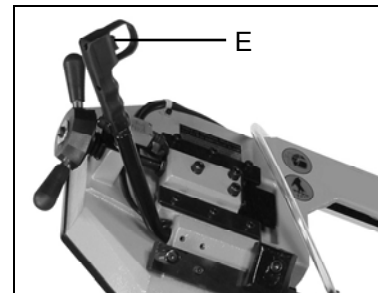

For model WP-270SH

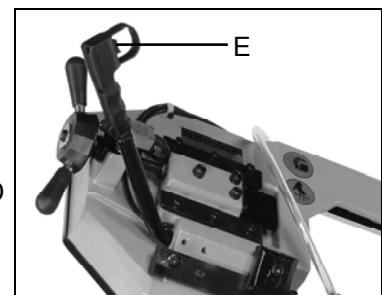
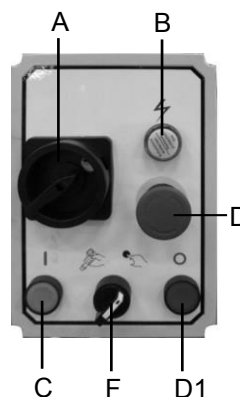

- A. Main connect switch and blade speed selection
- B. Power indicator light
- C. Start cutting push button by hydraulic control.
- D. Emergency push button
- D1 Stop cutting button to stop cutting cycle
- E. Manual control handle by trigger switch.
- F. Manual / Hydraulic selector

3.3 Vise Adjustment

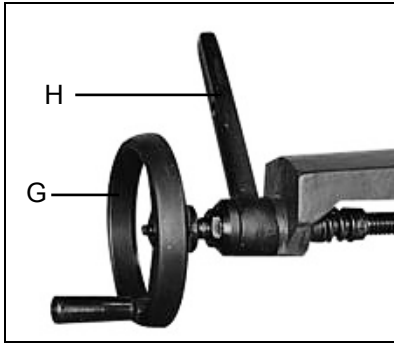

Clamping the Work Piece

- Place the work piece between the vise jaws and have it rest next to the fixed vise jaw.
- Rotate the hand wheel (G) clockwise to close the free vise jaw on to the work piece, and tighten.
- Rotate the hand wheel (G) counter-clockwise to release.
- Lever (H) can be used to rapidly lock and release the work piece by allowing a shallow gap between the vise and work piece. Then rotate lever (H) counter-clockwise to lock and clockwise to release.

3.4 Cutting Angle Adjustment

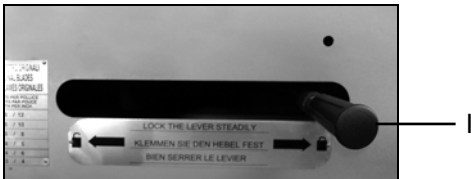

Cutting at angles

- Angle can be cut up to 60°.
- Unlock lever (I) by pushing it to the left side.
- Rotate the saw bow to the desired angle by following the index on the scale.
- Lock lever (I) by pushing to the right side.

3.5 The Base

The base is a structure supporting the saw bow, the vise, the bar stop, the work piece supporter, pump, swing arm, and the coolant return plate for the support of the material. The base houses the cooling liquid tank.

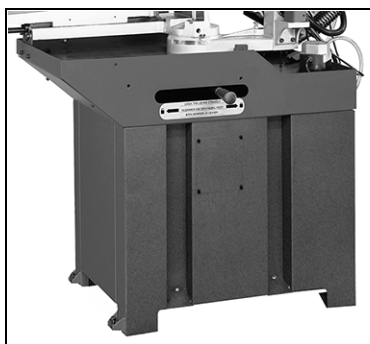

4 OPERATING AND ADVICE ON USING YOUR BANDSAW

4.1 The Operation Cycle

Before operating the machine, all the main parts of the machine must be set to the optimum conditions.

Power and blade speed select switch



There are three positions that can be selected, Off, Rabbit or Turtle on the main switch, if select blade speed must be exactly turned towards Rabbit or Turtle sign in cutting situation.

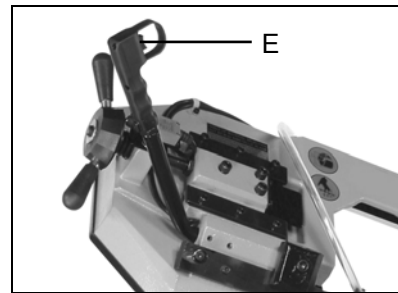

The WP-270S is equipped with a manually triggered handle switch.

1. Manual Operation of 270S



- Load work piece and clamp it properly.
- Turn on main connect switch (A) to the ON position (Fast speed or Low speed). Check to see that the indicator light (B) is lit.
- Hold the control handle (E) of the saw bow.
- Squeeze the trigger on the control handle (E) to start the blade and lower saw bow to begin cutting.
- When the saw bow reaches the bottom, release the trigger switch and the blade will stop.
- Keep hold of the control handle to control the saw head return to the start position.

2. Manual Operation of 270SH

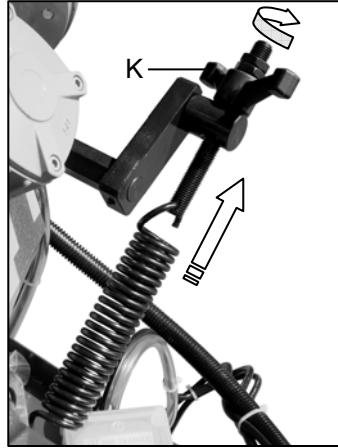
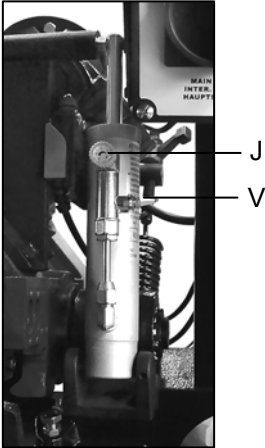

- Reduce the bow weight. Rotate the wing nut (K) clockwise to increase the tension on the spring.
 - Load work piece and clamp it properly.
 - Turn on main connect switch (A) to the ON position. Check to see that the indicator light (B) is lit.
 - Select manual control mode. Turn the control switch (F) to manual control mode for trigger operation.
 - Hold the control handle (E) of the saw bow.
 - Fully open the flow control knob (J) by rotating counter-clockwise to the maximum, and open the on/off hydraulic switch (V) to on position..
 - Squeeze the trigger on the control handle (E) to start the blade and lower saw bow to begin cutting.
 - When the saw bow reaches the bottom the micro-switch will activate and the blade will stop.
 - Keep hold of the control handle to control the return to the start position.
 - Close the hydraulic regulation lever (V).
 - The cutting operation is complete. Reset the work piece to continue the next cutting cycle.
- Close the hydraulic regulation lever (V) by switching it clockwise.
 - Increase the bow weight. Rotate the wing nut (K) counter clockwise to reduce the spring tension.
 - Load work piece and clamp it properly.
 - Turn main connect switch (A) to the ON position. Check to see that the indicator light (B) is lit.
 - Select Hydraulic mode on control switch (F), turn the switch to the right.
 - Press the start button (C). The coolant system should activate at the same time.
 - Open the hydraulic regulation lever (V) by switching it counter-clockwise.
 - Slightly turn the hydraulic flow control knob (J) counter-clockwise from 2-3 to control the saw bow's descent rate.
 - When the saw bow reaches the bottom the micro-switch will activate and the blade will stop.
 - Lift the saw bow to the appropriate height close the hydraulic regulation lever (V) by rotating it clockwise all the way to the end.
 - The machine is now ready for the next cutting operation.

If may has an emergency situation should occur.

- Press the emergency push button (D) down to shut off all functions. To release the emergency pushbutton rotate the mushroom shaped button in the clock-wise direction. The button will pop up, then the cutting cycle can be restarted.

4.2 Recommendations for Using the Machine

The machine has been designed to cut metal building materials, with different shapes and profiles, used in workshops, turner's shops and general mechanical structural work.

Only one operator is needed to use the machine, that must stand as shown in the picture.

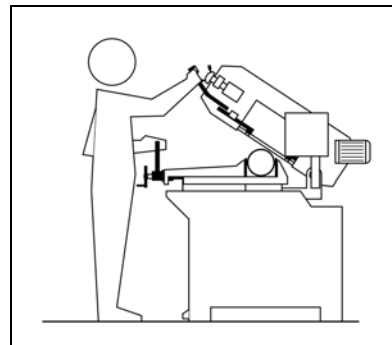

3. Semi-auto Cutting Operation of 270SH

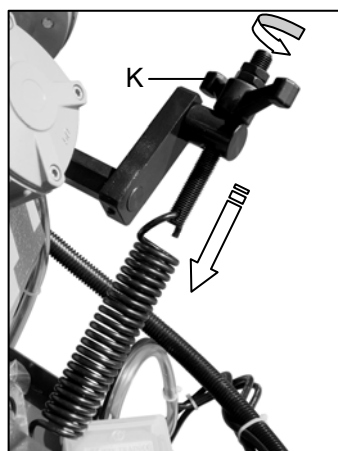
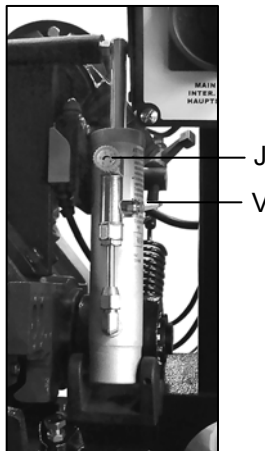

!! WARNING

Failure to fully close the hydraulic flow control knob (J) and locking the hydraulic regulation lever (V) can result in serious injury. The saw bow may drop suddenly when changing the spring tension.

- Before starting each cutting operation, ensure that the part is firmly clamped in the vise and that the end is suitably supported.
- These figures below show examples of suitable clamping of different section bars, bearing in mind the cutting capacities of the machine in order to achieve a good efficiency and blade durability.

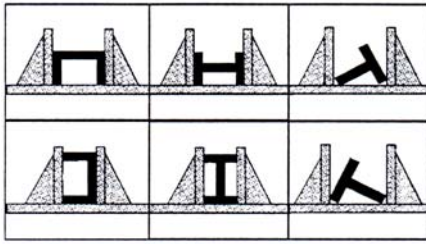

- Do not use blades of a different size from those stated in the machine specifications.
- If the blade gets stuck in the cut, release the running but ton immediately, switch off the machine, open the vise slowly, remove the part and check that the blade or its teeth are not broken. If they are broken, change the tool.
- Before carrying out any repairs on the machine, consult the dealer.

5 ADJUSTING YOUR MACHINE

5.1 Blade Tension Assembly

Blade tension is important to the proper operation of the saw. Proper blade tension is 700 to 900 kg/mm² as measured on a blade tension gauge.

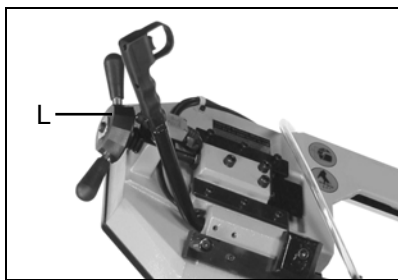

To set the blade tension without the use of a tension gauge:

- Disconnect the machine from the power source.
- Install blade between wheel and insert blade between bearings on blade guides.
- Tension blade slightly to remove any sag in blade between blade wheels.
- Turn blade tension handle (L) one and three quarter to two revolutions clockwise. To test press the flat side of the blade with your thumb, if moves with 2mm-3mm range then it is set correctly.
- After blade has been completely installed, close covers, connect the power source, and run saw for two to three minutes so blade can seat properly.
- Disconnect machine from the power source. Open cover and loosen blade just until it begins to sag.
- Tighten blade until it becomes straight between blade wheel and all sag has been eliminated.
- Tighten blade by turning blade tension wheel two full revolutions. Blade is now property tensioned and ready for use.

Close covers and connect machine to the power source.

5.2 Aligning the Flywheel

The flywheel's alignment may need adjustment to allow the saw blade to track correctly. Poor flywheel alignment can cause damage to the saw blade or to allow the blade to ride off the blade wheels.

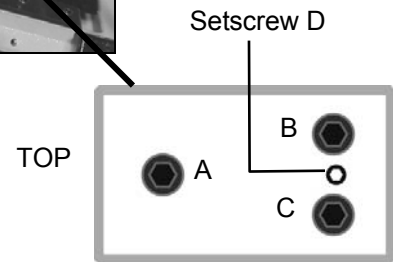
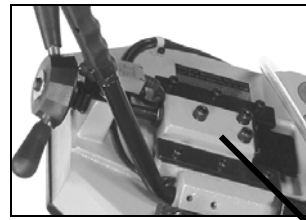

- Raise the saw bow to a usable work height.
- Disconnect the power supply.
- Loosen the Hex nut screws A, B, and C.
- Use an Allen wrench on setscrew D to adjust the tilt of the flywheel.
- Turning the setscrew, D clockwise will tilt flywheel so that the blade will ride closer to the flange.
- Turning the setscrew, D counter-clockwise will tilt the flywheel so that the blade will ride away from the flange. If the blade rides too far then it will come off.
- After the adjustment is finish, fasten the Hex nut screws in this order: A, B, and C.

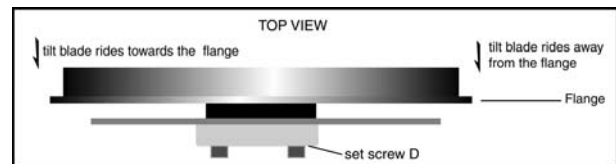

5.3 Checking the Adjustment of the Blade

Use a strip of scrap paper and slide it between the blade and the flywheel while it is running.

- If the paper is cut then the blade is riding too close to the flange. Readjust.
- If the paper folds or creases then the blade is seated properly.
- If you notice that the blade is riding away from the flange, then readjust.

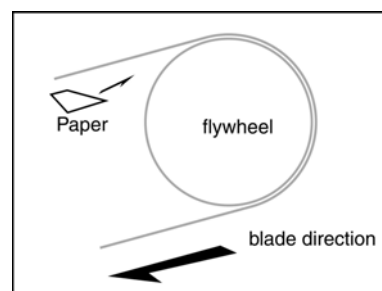

5.4 Adjusting the Blade Guide

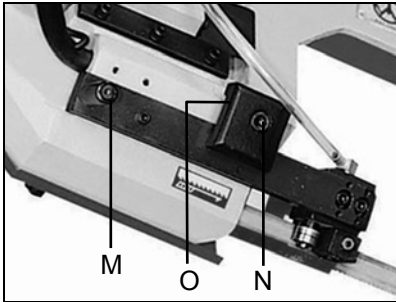

- Disconnect the machine from the power source.
- Release the extension bar for the blade guide block. Use the hex socket screw (N) to loosen the clamping block (O).
- Hold the revolving handle (M) and slide the blade guide block to be as close as possible to the material without interfering with the cut.
- Tighten the hex socket screw (N).
- Reconnect the machine to power source.

Blade guide blocks

The blade is guided by means of pads and bearings that are set in place during inspection as per the thickness of the blade with minimum play as shown in the figure. In case the blade needs to be replaced, make sure to always install 0.9mm thick blades for which the blade guide pad and bearings have been adjusted.

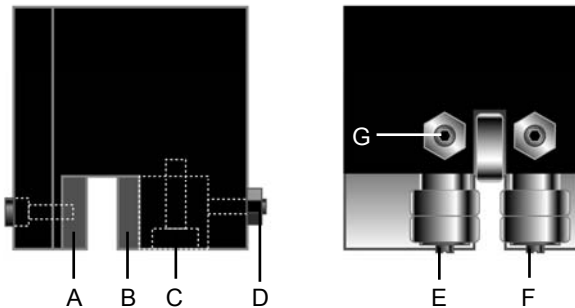

For saw blades clamping gaps, the adjustment should be carried out as follows:

Note: the position for pad (A) and bearing (F) are fixed and cannot be adjusted.

- Loosen screw (C), nut (D), and setscrew (D) to widening the passage between the pads (A and B).
- Loosen the nut (G) and setscrew (G) and rotate the shaft screw (E) with a flat head screwdriver to widen the passage between the bearings (E and F).
- To mount the new blade: adjust the pad (B) to the blade then loosen the setscrew to allow a play of 0.04 mm for the movement of the saw blade. Lock the nut (D), screw (D), and screw (C), Rotate the shaft (E) until the bearings rest against the blade as indicated in the figure and then secure the setscrew (G) and nut (G).

BEFORE PERFORMING THE FOLLOWING OPERATIONS, THE ELECTRIC POWER SUPPLY AND THE POWER CABLE MUST BE COMPLETELY DISCONNECTED.

5.5 Changing the Blade

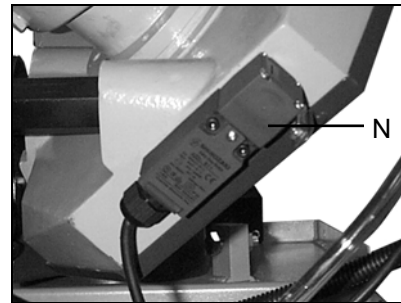

To change the blade:

- Lift the saw bow.
- Loosen the blade with the blade tension hand wheel, remove the mobile blade-guard cover, open the flywheel guards and remove the old blade from the flywheels and the blade guide blocks.
- Assemble the new blade by placing it first between the pads and then on the race of the flywheels, paying particular attention to the cutting direction of the teeth.
- Tension the blade and make sure it perfectly fits inside the seat of the flywheels.
- Assemble the mobile blade-guide end, the flywheel guard, and fasten it with the relative knobs. Check the safety micro-switch (N) is activated otherwise when electricity is applied the machine will not start.

BLADE CUTTING DIRECTION



WARNING: Always assemble blades having dimensions specified in this manual and for which the blade guide heads have been set; otherwise, see chapter on "Description of the operating cycle" in the section Starting-up.

6 ROUTINE AND SPECIAL MAINTENANCE

THE MAINTENANCE JOBS ARE LISTED BELOW, DIVIDED INTO DAILY, WEEKLY, MONTHLY AND SIX-MONTHLY INTERVALS. IF THE FOLLOWING OPERATIONS ARE NEGLECTED, THE RESULT WILL BE PREMATURE WEAR OF THE MACHINE AND POOR PERFORMANCE.

6.1 Daily maintenance

- General cleaning of the machine to remove accumulated shavings.
- Clean the lubricating coolant drain hole to avoid excess fluid.
- Top off the level of lubricating coolant.
- Check blade for wear.
- Rise of saw frame to top position and partial slackening of the blade to avoid useless yield stress.
- Check functionality of the shields and emergency stops.

6.2 Weekly Maintenance

- Thorough cleaning of the machine to remove shavings, especially from the lubricant fluid tank.
- Removal of pump from its housing, cleaning of the suction filter and suction zone.
- Clean the filter of the pump suction head and the suction area.
- Use compressed air to clean the blade guides (guide bearings and drain hole of the lubricating cooling).
- Cleaning flywheel housings and blade sliding surfaces on flywheels.

6.3 Monthly Maintenance

- Check the tightening of the motor flywheel screws.
- Check that the blade guide bearings on the heads are perfect running condition.
- Check the tightening of the screws of the gear motor, pump, and accident protection guarding.

6.4 Six-Monthly Maintenance

- Continuity test of the equipment potential protection circuit.

6.5 Oils for Lubricating Coolant

Considering the vast range of products on the market, the user can choose the one most suited to their own requirements, using as reference the type SHELL LUTEM OIL ECO. THE MINIMUM PERCENTAGE OF OIL DILUTED IN WATER IS 8 - 10 %.

6.6 Oil Disposal

The disposal of these products is controlled by strict regulations. Please see the Chapter on "Machine dimensions Transport - Installation" in the section on Dismantling.

6.7 Coolant system

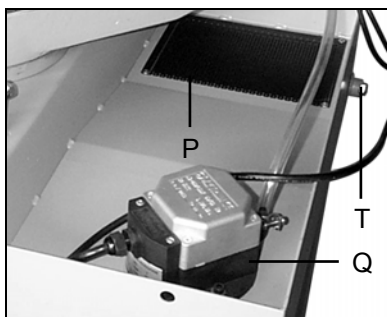

Cleaning the tank

- Use hex wrench to open the plug (T). Allow the coolant to drain-out.
- Remove the grate (P) by loosening the four setscrews.
- Remove the pump (Q) by loosening the four setscrews.
- Use a vacuum cleaner to vacuum chips and debris from the tank.
- Replace the plug (T).
- Thoroughly clean the pump (Q) and replace.
- Fill the tank with coolant to approximately 25mm below the grate (P).
- Replace the grate (P).

6.8 The Gearbox

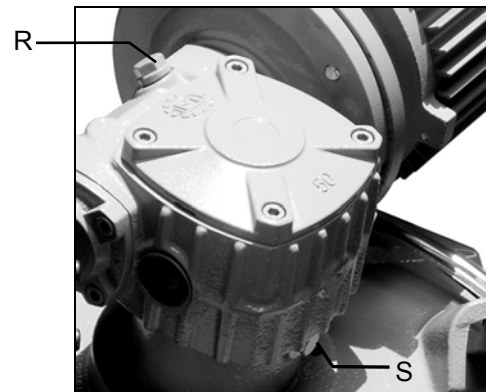

The gearbox requires periodic changing of oil. The oil must be changed by the first six months of a new machine and every year thereafter.

To change the gear box oil

- Disconnect the machine from the power source.
- Raise the saw bow to vertical position.
- Release the drain hole (S) to draw off gear oil by loosening the oil fill bolt (R).
- Replace the drain plug bolt (S) after oil completely flows off.
- Place the saw bow back to horizontal position.
- Fill Gear box with approximately .3 liter of gear oil through the hole of the oil fill bolt (R).



For reference, use SHELL type gear oil or Mobile gear oil #90.

6.9 Special Maintenance

Special maintenance must be conducted by skilled personnel. We advise contacting your nearest dealer and/or importer. Also the reset of protective and safety equipment and devices (of the reducer), the motor, the motor pump, and other electrical components requires special maintenance.

7 TECHNICAL CHARACTERISTICS

7.1 Table of Cutting Capacity and Technical Details

CUTTING CAPACITY			
90°	220mm (8.6")	215mm (8.4")	110x260mm (4.3"x10.2")
45°	150mm (5.9")	145mm (5.7")	110x155mm (4.3"x6.1")
60°	90mm (3.5")	85mm (3.3")	80x95mm (3.1"x3.7")

BLADE MOTOR	kW	1.1
BLADE SIZE	mm	27x0.9x2460
BLADE SPEED	m/min	36 / 72
WORKING TABLE HEIGHT	mm	840
MACHINE WEIGHT	kg	216

TYPES OF STEEL						CHARACTERISTICS		
USE	I UNI	D DIN	F AF NOR	GB SB	USA AISI-SAE	Hardness BRINELL HB	Hardness ROCKWELL HRB	R=N/mm ²
Construction steels	Fe360	St37	E24	----	----	116	67	360÷480
	Fe430	St44	E28	43	----	148	80	430÷560
	Fe510	St52	E36	50	----	180	88	510÷660
Carbon steels	C20	CK20	XC20	060 A 20	1020	198	93	540÷690
	C40	CK40	XC42H1	060 A 40	1040	198	93	700÷840
	C50	CK50	----	----	1050	202	94	760÷900
	C60	CK60	XC55	060 A 62	1060	202	94	830÷980
Spring steels	50CrV4	50CrV4	50CV4	735 A 50	6150	207	95	1140÷1330
	60SiCr8	60SiCr7	----	----	9262	224	98	1220÷1400
Alloyed steels for hardening and tempering and for nitriding	35CrMo4	34CrMo4	35CD4	708 A 37	4135	220	98	780÷930
	39NiCrMo4	36CrNiMo4	39NCD4	----	9840	228	99	880÷1080
	41CrAlMo7	41CrAlMo7	40CADG12	905 M 39	----	232	100	930÷1130
Alloyed casehardening steels	18NiCrMo7	----	20NCD7	En 325	4320	232	100	760÷1030
	20NiCrMo2	21NiCrMo2	20NCD2	805 H 20	4315	224	98	690÷980
Alloyed for bearings	100Cr6	100Cr6	100C6	534 A 99	52100	207	95	690÷980
Tool steel	52NiCrMoKU	56NiCrMoV7C100K	----	----	----	244	102	800÷1030
	C100KU	C100W1	----	BS 1	S-1	212	96	710÷980
	X210Cr13KU	X210Cr12	Z200C12	BD2-BD3	D6-D3	252	103	820÷1060
	58SiMo8KU	----	Y60SC7	----	S5	244	102	800÷1030
Stainless steels	X12Cr13	4001	----	----	410	202	94	670÷885
	X5CrNi1810	4301	Z5CN18.09	304 C 12	304	202	94	590÷685
	X8CrNi1910	----	----	----	----	202	94	540÷685
	X8CrNiMo1713	4401	Z6CDN17.12	316 S 16	316	202	94	490÷685
Copper alloys Special brass Bronze	Aluminium copper alloy G-CuAl11Fe4Ni4 UNI 5275					220	98	620÷685
	Special manganese/silicon brass G-CuZn36Si1Pb1 UNI5038					140	77	375÷440
	Manganese bronze SAE43 - SAE430					120	69	320÷410
	Phosphor bronze G-CuSn12 UNI 7013/2a					100	56.5	265÷314
Cast iron	Gray pig iron		G25			212	96	245
	Spheroidal graphite cast iron		GS600			232	100	600
	Malleable cast iron		W40-05			222	98	420

8 MATERIAL CLASSIFICATIONS AND CHOICE OF TOOL

Since the aim is to obtain excellent cutting quality, the various parameters such as hardness of the material, shape and thickness, transverse cutting section of the part to be cut, selection of the type of cutting blade, cutting speed and control of saw frame lowering. These specifications must therefore be harmoniously combined in a single operating condition according to practical considerations and common sense, so as to achieve an optimum condition that does not require countless operations to prepare the machine when there are many variations in the job to be performed. The various problems that crop up from time to time will be

solved more easily if the operator has a good knowledge of these specifications.

8.1 Definition of materials

The table above lists the characteristics of the materials to be cut. So that the correct tools to use, can be chosen.

8.2 Selecting blade

First of all the pitch of the teeth must be chosen, in other words, the number of teeth per inch (25,4 mm) suitable for the material to be cut, according to these criteria:

- Parts with a thin and/or variable section such as profiles, pipes and plate, need fine tooth, so that the number of teeth used simultaneously in cutting is from 3 to 6;

- Parts with large transverse sections and solid sections need coarse tooth to allow for the greater volume of the shavings and better tooth penetration;
- Parts made of soft material or plastic (light alloys, mild bronze, Teflon, wood, etc.) also require widely spaced tooth.
- Pieces cut in bundles require combo tooth design.

8.3 Teeth pitch

As already stated, this depends on the following factors:

- **Hardness of the material**
- **Dimensions of the section**
- **Wall thickness.**

BLADE TEETH SELECTION TABLE		
THICKNESS MM	Z CONTINUOUS TOOTH DESIGN	Z COMBO TOOTH DESIGN
TILL 1.5	14	10/14
FROM 1 TO 2	8	8/12
FROM 2 TO 3	6	6/10
FROM 3 TO 5	6	5/8
FROM 4 TO 6	6	4/6
MORE THAN 6	4	4/6

SOLID Ø OR L MM	Z CONTINUOUS TOOTH DESIGN	Z COMBO TOOTH DESIGN
TILL 30	8	5/8
FROM 30 TO 60	6	4/6
FROM 40 TO 80	4	4/6
MORE THAN 90	3	3/4

8.4 Cutting and advance speed

The cutting speed (m/min) and the advance speed (cm²/min = area traveled by the disk teeth when removing shavings) are limited by the development of heat close to the tips of the teeth.

- The cutting speed is subordinate to the resistance of the material ($R = N/mm^2$), to its hardness (HRC) and to the dimensions of the widest section.
- Too high an advance speed (= lowering of the saw frame) tends to cause the disk to deviate from the ideal cutting path, producing non rectilinear cuts on both the vertical and the horizontal plane.

The best combination of these two parameters can be seen directly examining the chips.

Long spiral-shaped chips indicate ideal cutting.

Very fine or pulverized chips indicate lack of feed and/or cutting pressure.

Thick and/or blue chips indicate overload of the blade.

8.5 Blade running-in

When cutting for the first time, it is good practice to run in the tool making a series of cuts at a low advance speed (= 30-35 cm²/min on material of average dimensions with respect to the cutting capacity and solid section of normal steel with $R = 410-510 N/mm^2$). Generously spraying the cutting area with lubricating coolant.

8.6 Blade structure

Bi-metal blades are the most commonly used. They consist of a silicon-steel blade backing by a laser welded high-speed steel (HSS) cutting edge. The type of stocks are classified in M2, M42, M51 and differ from each other because of their major hardness due to the increasing percentage of Cobalt (Cc) and molybdenum (Mo) contained in the metal alloy

8.7 Blade type

They differ essentially in their constructive characteristics, such as:

- **Shape and cutting angle** of tooth
- **Pitch**
- **Set**

Shape and angle of tooth

REGULAR TOOTH: 0° rake and constant pitch.



Most common form for transversal or inclined cutting of solid small and average cross-sections or pipes, in laminated mild steel and gray iron or general metal.

POSITIVE RAKE TOOTH: 9° - 10° positive rake and constant pitch.



Particular use for crosswise or inclined cuts in solid sections or large pipes, but above all harder materials (highly alloyed and stainless steels, special bronze and forge pig iron).

COMBO TOOTH: pitch varies between teeth and consequently varying teeth size and varying gullet depths. Pitch varies between teeth, which ensures a smoother, quieter cut and longer blade life owing to the lack of vibration.

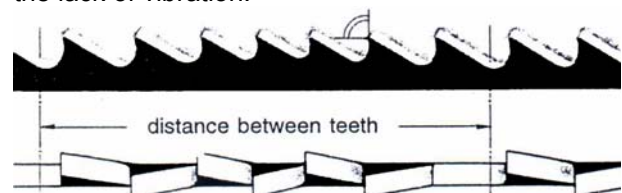

Another advantage offered in the use of this type of blade in the fact that with an only blade it is possible to cut a wide range of different materials in size and type.

COMBO TOOTH: 9° - 10° positive rake.

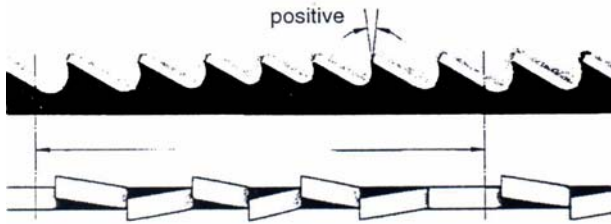

This type of blade is the most suitable for the cutting of section bars and large and thick pipes as well as for the cutting of solid bars at maximum machine capacity. Available pitches: 3-4/4-6.

SETS

Saw teeth bent out of the plane of the saw body, resulting in a wide cut in the workpiece.

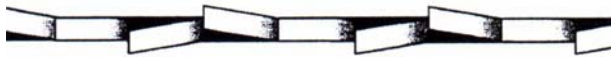

REGULAR OR RAKER SET: Cutting teeth right and left, alternated by a straight tooth.

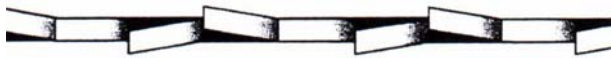

Of general use for materials with dimensions superior to 5 mm. Used for the cutting of steel, castings and hard nonferrous materials.

9 NOISE TESTS

The test was held under environmental noise levels of 65db. Noise measurements with the machine operating unload was 71db. Noise level during the cutting of mild carbon steel was 73db.

NOTE: with the machine operating, the noise level will vary according to the different materials being processed. The user must therefore assess the intensity and if necessary provide the operators with the necessary personal protection, as required by Law 277/1991.

WAVY SET: Set in smooth waves.



This set is associated with very fine teeth and it is mainly used for the cutting of pipes and thin section bars (from 1 to 3 mm).

ALTERNATE SET (IN GROUPS): Groups of cutting teeth right and left, alternated by a straight tooth.



This set is associated with very fine teeth and it is used for extremely thin materials (less than 1mm).

ALTERNATE SET (INDIVIDUAL TEETH): Cutting teeth right and left.



This set is used for the cutting of nonferrous soft materials, plastics and wood.

10 WIRING DIAGRAMS

Model WP-270S

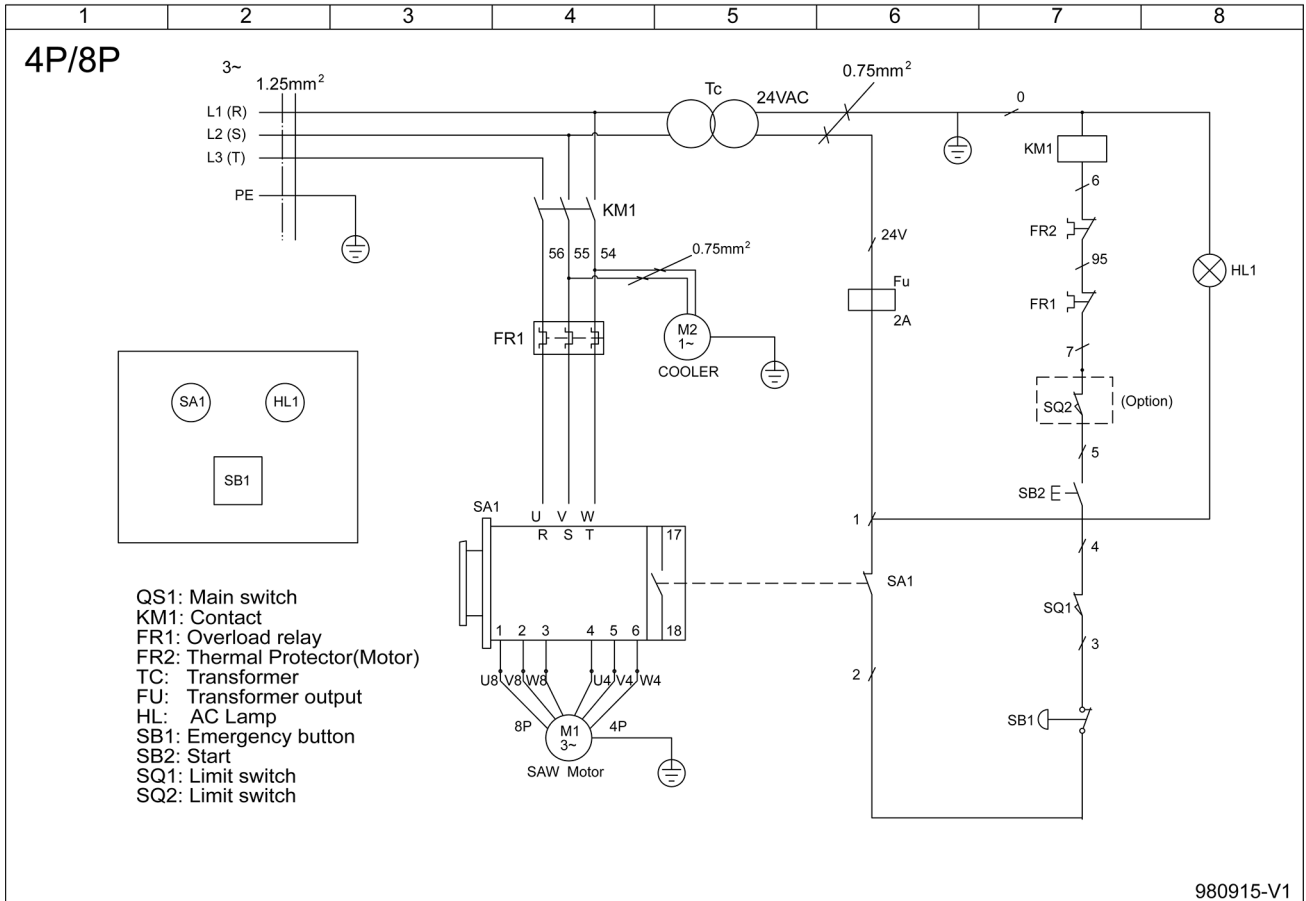
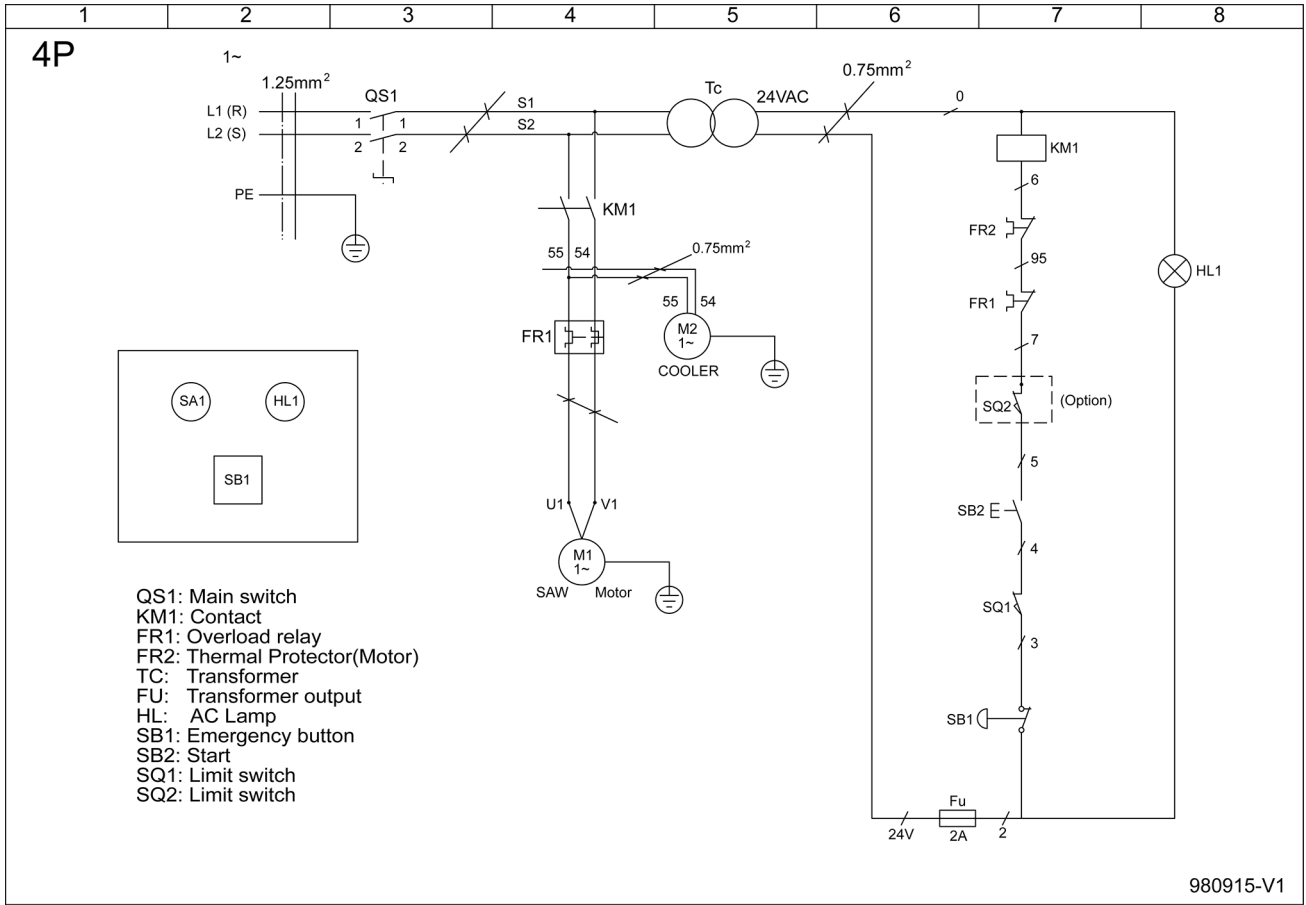

Model WP-270SH

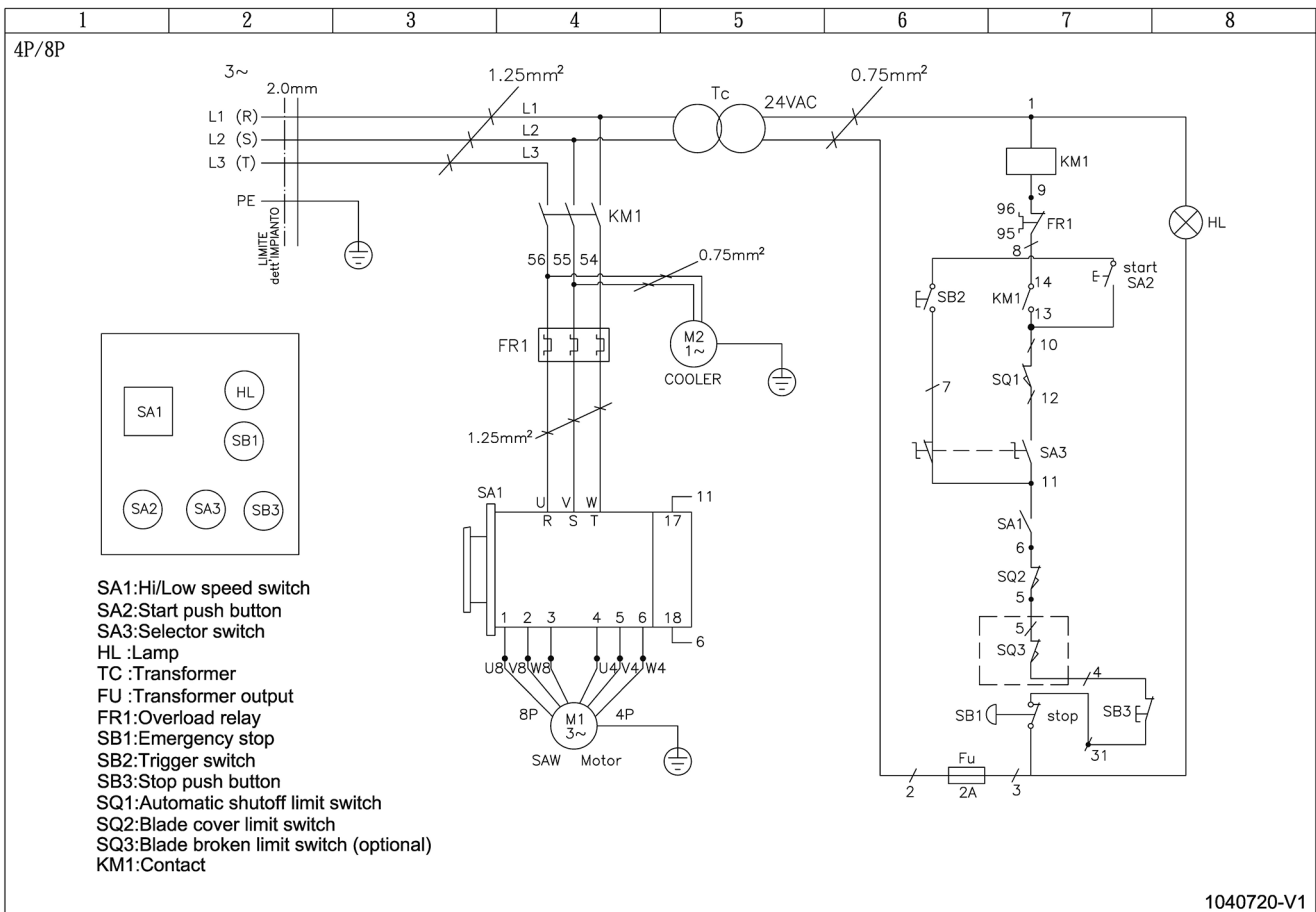
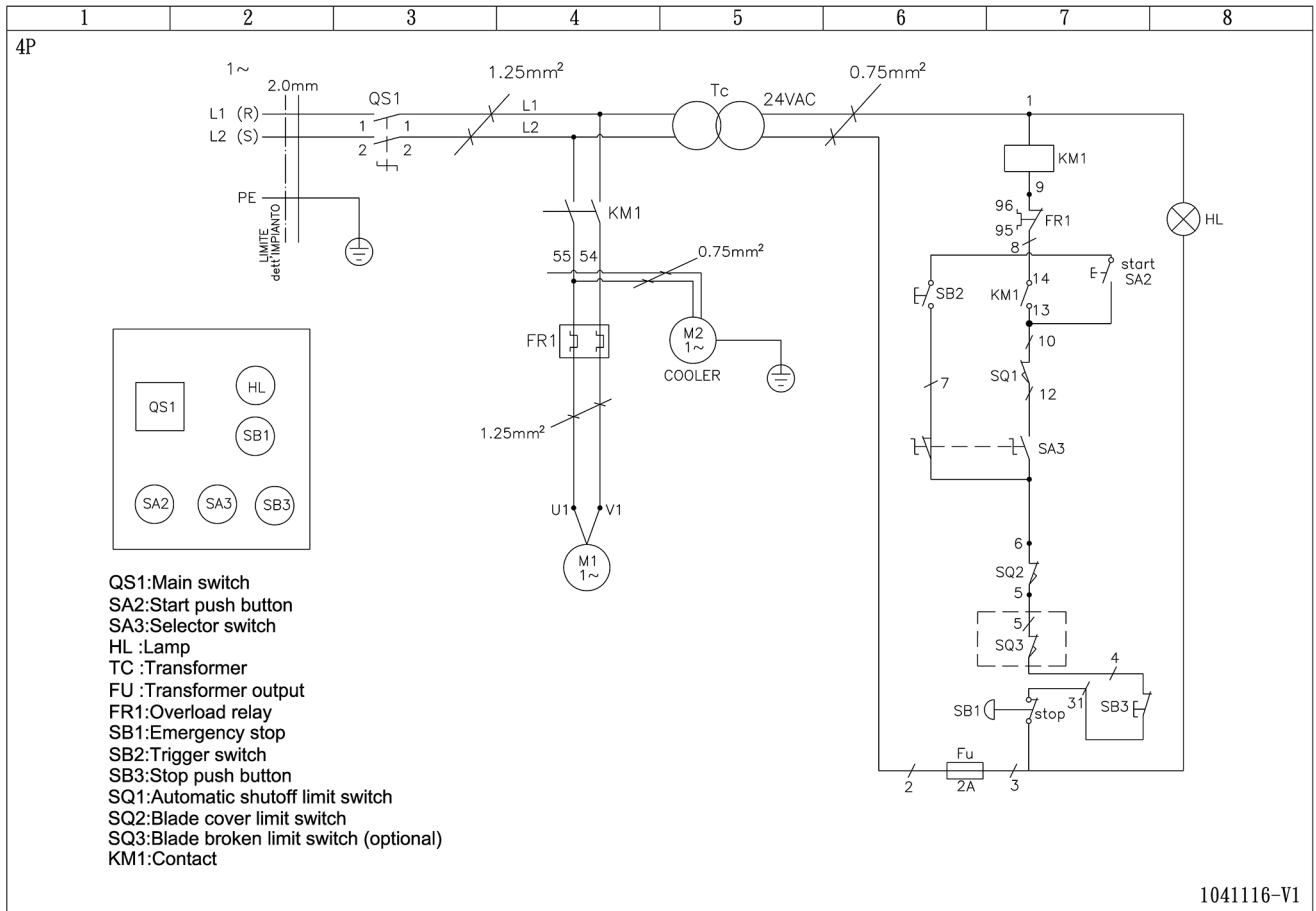

11 TROUBLESHOOTING

This chapter lists the probable faults and malfunctions that could occur while the machine is being used and suggests possible remedies for solving them.

11.1 Blade and cut diagnosis

FAULT

PROBABLE CAUSE

REMEDY

<u>FAULT</u>	<u>PROBABLE CAUSE</u>	<u>REMEDY</u>
<p>TOOTH BREAKAGE</p> 	<p>Too fast advance</p> <p>Wrong cutting speed</p> <p>Wrong tooth pitch</p> <p>Chips sticking onto teeth and in the gullets or material that gums</p> <p>Defects on the material or material too hard</p> <p>Ineffective gripping of the part in the vise</p> <p>The blade gets stuck in the material</p> <p>Starting cut on sharp or irregular section bars</p> <p>Poor quality blade</p> <p>Previously broken tooth left in the cut</p> <p>Cutting resumed on a groove made previously</p> <p>Vibrations</p> <p>Wrong tooth pitch or shape</p> <p>Insufficient lubricating, refrigerant, or wrong emulsion</p> <p>Teeth positioned in the direction opposite the cutting direction</p>	<p>Decrease advance, exerting less cutting pressure. Adjust the braking device.</p> <p>Change speed and/or type of blade. See chapter on "Material classification and blade selection", in the section <i>Blade selection table according to cutting and feed speed</i>.</p> <p>Choose a suitable blade. See Chapter "Material classification and blade selection".</p> <p>Check for clogging of coolant drain holes on the blade-guide blocks and that flow is plentiful in order to facilitate the removal of chips from the blade.</p> <p>Material surfaces can be oxidized or covered with impurities making them, at the beginning of the cut, harder than the blade itself, or have hardened areas or inclusions inside the section due to productive agents used such as casting sand, welding wastes, etc. Avoid cutting these materials or in a situation a cut has to be made use extreme care, cleaning and remove any such impurities as quickly as possible.</p> <p>Check the gripping of the part.</p> <p>Reduce feed and exert less cutting pressure.</p> <p>Pay more attention when you start cutting.</p> <p>Use a superior quality blade.</p> <p>Accurately remove all the parts left in.</p> <p>Make the cut elsewhere, turning the part.</p> <p>Check gripping of the part.</p> <p>Replace blade with a more suitable one. See "Material classification and blade selection" in the <i>Blade Types</i> section. Adjust blade guide pads.</p> <p>Check level of liquid in the tank. Increase the flow of lubricating refrigerant, checking that the hole and the liquid outlet pipe are not blocked. Check the emulsion percentage.</p> <p>Turn teeth to correct direction.</p>

FAULT

PROBABLE CAUSE

REMEDY

PREMATURE BLADE WEAR

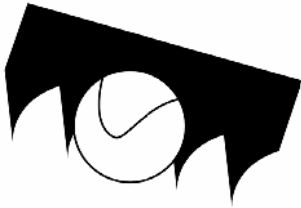

- Faulty running-in of blade
- Teeth positioned in the direction opposite the cutting direction
- Poor quality blade
- Too fast advance
- Wrong cutting speed
- Defects on the material or material too hard
- Insufficient lubricating refrigerant or wrong emulsion

- See "Material classification and blade selection" in the *Blade running-in* section.
- Turn teeth in correct direction.
- Use a superior quality blade.
- Decrease advance, exerting less cutting pressure. Adjust the braking device.
- Change speed and/or type of blade. See chapter on "Material classification and blade selection," in the section *Blade selection table according to cutting and feed speed*.
- Material surfaces can be oxidized or covered with impurities making them, at the beginning of the cut, harder than the blade itself, or have hardened areas or inclusions inside the section due to productive agents used such as casting sand, welding wastes, etc. Avoid cutting these materials or perform cutting with extreme care, cleaning and remove such impurities as quickly as possible.
- Check level of liquid in the tank. Increase the flow of lubricating coolant, checking that the coolant nozzle and pipe are not blocked. Check the emulsion percentage.

BLADE BREAKAGE

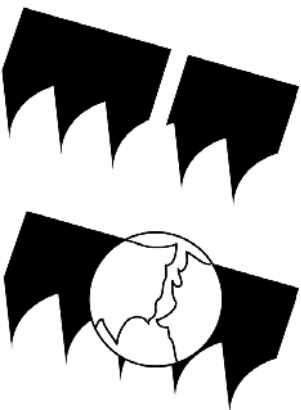

- Faulty welding of blade
- Too fast advance
- Wrong cutting speed
- Wrong tooth pitch
- Ineffective gripping of the part in the vice
- Blade touching material at beginning of cut
- Remedy

- The welding of the blade is of utmost importance. The meeting surfaces must perfectly match and once they are welded they must have no inclusions or bubbles; the welded part must be perfectly smooth and even. They must be evenly thick and have no bulges that can cause dents or instant breakage when sliding between the blade guide pads.
- Decrease advance, exerting less cutting pressure. Adjust the braking device.
- Change speed and/or type of blade.
- See chapter on "Material classification and blade selection", in the section *Blade selection table according to cutting and feed speed*.
- Choose a suitable blade. See Chapter "Material classification and blade selection."
- Check the gripping of the part.
- At the beginning of the cutting process, never lower the saw bow before starting the blade motor.

FAULT

PROBABLE CAUSE

REMEDY

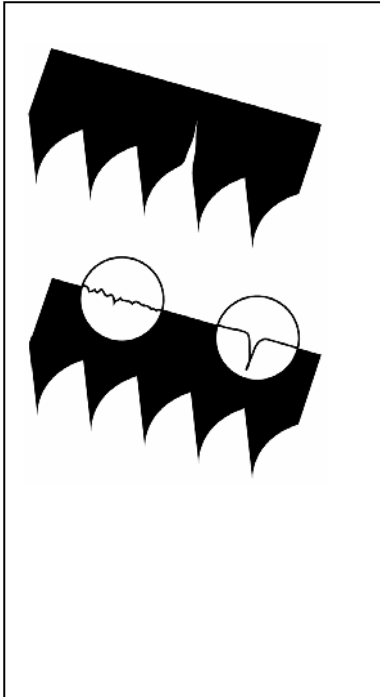

Blade guide pads not regulated or dirty because of lack of maintenance

Blade guide block too far from material to be cut

Improper position of blade on flywheels

Insufficient lubricating coolant or wrong emulsion

Check distance between pads (see "Machine adjustments" in the *Blade Guide Blocks* section): extremely accurate guiding may cause cracks and breakage of the tooth. Use extreme care when cleaning.

Approach head as near as possible to material to be cut so that only the blade section employed in the cut is free, this will prevent deflections that would excessively stress the blade.

The back of blade rubs against the support due to deformed or poorly welded bands (tapered), causing cracks and swelling of the back contour.

Check level of liquid in the tank. Increase the flow of lubricating refrigerant, checking that the hole and the liquid outlet pipe are not blocked. Check the emulsion percentage.

STEAKED OR ETCHED BANDS

Damaged or chipped blade guide pads

Tight or slackened blade guide bearings.

Replace them.

Adjust them (see Chapter "Machine adjustments" in *Blade guide* section).

CUTS OFF THE STRAIGHT

Blade not parallel as to the counter service

Blade not perpendicular due to the excessive play between the guide pads and maladjustment of the blocks

Too fast advance

Worn out blade

Wrong tooth pitch

Check fastenings of the blade guide blocks as to the counter-vice so that they are not too loose and adjust blocks vertically; bring into line the position of the degrees and if necessary adjust the stop screws of the degree cuts.

Check and vertically re-adjust the blade guide blocks; reset proper side guide play (see Chapter "Machine adjustments" In *Blade guide* section).

Decrease advance, exerting less cutting pressure. Adjust the braking device.

Approach it as near as possible to material to be cut so that only the blade section employed in the cut is free, this will prevent deflections that would excessively stress the blade.

Replace it. Blade with major density of teeth is being used, try using one with less teeth (see Chapter "Material classification and blade selection" in the *Blade Types* section).

FAULT

PROBABLE CAUSE

REMEDY

	Broken teeth Insufficient lubricating refrigerant or wrong emulsion	Irregular work of the blade due to the lack of teeth can cause deflection in the cut; check blade and if necessary replace it. Check level of liquid in the tank. Increase the flow of lubricating coolant, checking that the hole and the liquid outlet pipe are not blocked. Check the emulsion <i>percentage</i> .
--	--	--

FAULTY CUT	Worn out flywheels Flywheel housing full of chips	The support and guide flange of the band are so worn out that they cannot ensure the alignment of the blade, causing faulty cutting; blade rolling and drawing tracks can have become tapered. Replace them. Clean with compressed air.
-------------------	--	---

STREAKED CUTTING SURFACE 	Too fast advance Poor quality blade Worn out blade or with chipped and/or broken teeth Wrong tooth pitch Blade guide block too far from material to be cut Insufficient lubricating coolant or wrong emulsion	Decrease advance, exerting less cutting pressure. Adjust the braking device. Use a superior quality blade. Replace it. Blade used probably has too large teeth, use one with more teeth (see " Material classification and blade selection " in the <i>Blade Types</i> section). Approach it as near as possible to material to be cut so that only the blade section employed in the cut is free, this will prevent deflections that would excessively stress the blade. Check level of liquid in the tank. Increase the flow of lubricating coolant, checking that the hole and the liquid outlet pipe are not blocked. Check the emulsion <i>percentage</i> .
---	--	--

NOISE ON GUIDE BLOCKS	Chipped bearings Worn out or damaged pads	Dirt and/or chips between blade and guide bearings. Replace them. Replace them.
------------------------------	--	---

PART LIST

Part No.	Description	Size No.	Q'ty	Part No.	Description	Size No.	Q'ty
1	Base (Right Part)		1	46	Movable Vise		1
1-1	Hex. Cap Bolt	M10x20	4	47	Plate		1
1-2	Washer	10x25x2	4	48	Flat Head Machine Screw	M6x16	2
2	Nut	M12	2	49	Compressed Spring		1
3	Hex. Cap Bolt	M12x40	2	50	Lead Screw		1
4	Base (Rear Part)		1	50-1	Hex. Socket Cap Screw	M8x16	1
5	Washer	8x18x2	8	50-2	Washer	8x18x2	1
6	Hex. Cap Bolt	M8x16	8	50-3	Key	5x5x15	1
7	Base (Front Part)		1	54	Vise Table		1
8	Base (Left Part)		1	55	Bar-Stop-Rod		1
9	Hex. Socket Cap Screw	M8x20	2	56A	Bar-Stop	Ø19	1
10	Spring Washer	M8	2	56-1	Nut	M8	1
10-1	Nut	M8	2	56-2	Knob	M8x30	1
10-2	Washer	8x18x2	2	64	Set Screw	M8x10	1
11	Hex. Socket Cap Screw	M8x20	2	64-1	Hex. Socket Cap Screw	M5x8	2
12	Spring Washer	M8	2	64-2	Scale Point		1
13	Washer	8x18x2	2	65	Pivot		1
14	Supporting Plate		1	66	Anti-Dust Cover	30mm	2
15	Roller Stand Bracket		1	67	Bearing	32006	2
16	Washer	10x25x2	2	68	Nut	M10	2
17	Spring Washer	M10	2	69	Hex. Cap Bolt	M10x25	1
18	Hex. Cap Bolt	M10x20	2	69-1	Hex. Cap Bolt	M10x25	1
19	Roller		1	70	Spring Hook		1
19-1	Roller Shaft		1	70-1	Nut (for WP-270SH)	M12	1
20	Washer	8x18x2	2	72	Star Washer	M30	1
21	Spring Washer	M8	2	73	Nut	M30	1
22	Hex. Socket Cap Screw	M8x20	2	74	Stop Button		1
23	Filter Net		1	75	Main Connect Switch	3PH	1
24	Round Head Screw	M5x10	4	75-1	0-1 Power Switch (not shown)	1PH	1
25	Hex. Socket Cap Screw	M6x25	2	76	Emergency Switch		1
26	Washer	6x13x1	2	77	Power Indicator Light		1
27	Hose Clamp	13mm	1	78H	Manual / Auto Selector		1
27-1	Hose	5/16x130cm	1	79H	Start Button		1
28	Pump		1	80H	PVC Panel		1
29	Plate		1	80	PVC Panel		1
29-1	Hex. Cap Bolt	M6x16	2	80-1	Plastic Box		1
29-2	Nut	M6	2	80-2	Terminal Connector		1
30	Coolant and Chip Tray		1	80-3	Grounding Plate		1
30-1	Front Plate		1	81	Fuse Seat		1
30-2	Hex. Socket Cap Screw	M6x8	2	82	Transformer		1
30-3	Coolant Plate		1	83	Overload Relay		1
30-4	Plug	M3/8"	1	84	Magnetic Connector		1
31	Hex. Cap Bolt	M12x40	2	85	Round Head Screw	M4x8	4
32	Nut	M12	2	85-1	Round Head Screw	M4x12	4
33	Hex. Socket Cap Screw	M5x8	4	85-2	Round Head Screw	M4x25	1
34	Plate		1	86	Control Bracket		1
38	Hand Wheel	6-1/2"	1	89	Hex. Socket Cap Screw	M8x20	2
39	Set Screw	M8x10	1	90	Spring Washer	M8	2
40	Nut	M20	1	91	Setting Bracket		1
40-1	Set Screw	M5x5	1	92	Spring Washer	M8	4
41	Bearing Bushing		1	93	Hex. Socket Cap Screw	M8x20	4
42	Bearing	51104	1	94	Swivel Arm		1
43	Lock Handle		1	94-1	Scale		1
44	Bushing		1	94-2	Rivet	2.3x4	2
45	Hex. Socket Cap Screw	M6x100	2	95	Disk		1

1071101

PART LIST

Part No.	Description	Size No.	Q'ty	Part No.	Description	Size No.	Q'ty
97	Oil Seal	4mmx518mm	1	166	Hose Clamp	13mm	1
98	Shaft		1	168	Hose	5/16x40cm	1
99	Nut		1	169	Saw Arm		1
100	Hex. Socket Cap Screw	M8x30	4	170	Limit Switch		1
101	Spring Washer	M8	4	170-1	Switch Pin		1
102	Set Screw	M8x10	1	171	Hex. Socket Cap Screw	M4x30	2
103	Hex. Socket Cap Screw	M6x25	1	172	Spring Shaft		1
104	Spring Washer	M6	1	172H-1	Spring Shaft		1
106	Locking Lever		1	172H-2	Setting Plate		1
109	Hex. Socket Cap Screw	M10x30	4	172H-3	Handle		1
110	Spring Washer	M10	4	172H-4	Nut	M16	2
111	Gib		2	172H-5	Bushing		1
112	Spring Washer	M8	6	172H-6	Adjustable Shaft		1
113	Hex. Socket Cap Screw	M8x20	6	172H-7	Spring		1
115	Front Ball Bearing Bracket		1	172H-8	Set Screw	M8x10	3
116	Set Screw	M6x12	4	172H-9	Washer	M16	1
117	Hex. Socket Cap Screw	M8x20	2	173	Spring		1
118	Hex. Socket Cap Screw	M12x50	1	174	Key	6x6x30	1
119	Setting Bracket		1	175	Motor		1
120	Hex. Socket Cap Screw	M6x8	1	175-1	Junction Box		1
121	Plastic Handle	M6x60	1	176	Spring Washer	M8	4
122	Hex. Socket Cap Screw	M6x8	2	177	Hex. Cap Bolt	M8x30	4
123	Cover Plate		1	178	Gear Box		1
127A	Slide		1	178-1	Vent Screw		1
127A-1	Spring Washer	M10	3	178-2	Key	8x7x40	1
127A-2	Hex. Socket Cap Screw	M10x45	3	179	Set Screw	M6x12	4
127A-3	Set Screw	M10x25	1	181	Hex. Socket Cap Screw	M8x20	2
128	Nut	M16	1	182	Front Blade Guard		1
131	Handle		2	183	Hex. Socket Cap Screw	M6x8	3
132	Handle Wheel		1	185	Bolt		2
133	Thrust Spring Washer		8	186	Front Ball Bearing Seat		1
134	Tension Shaft		1	187	Pipe Fitting	1/4Px5/16	1
137	Set Screw	M8x10	2	188	Rear Blade Guard		1
138	Rod		1	189	Blade Guide		2
139	Nut	M16	1	190	Hex. Socket Cap Screw	M6x8	2
140	Trigger Switch		1	191	Rear Ball Bearing Seat		1
141A	Shaft		1	192	Pipe Fitting	1/4Px5/16	1
142	Bearing	6006ZZ	2	193	Set Screw	M6x12	2
143	Idle Flywheel		1	193-1	Nut	M6	2
148	Blade		1	194	Hex. Cap Bolt	M6x12	2
149	Blade Cover		1	195	Washer	6x13x1	2
150	Knob Bolt	M6x12	4	198	Bracket		1
151	Round Head Screw	M4x8	2	199A	Brush	Ø50	1
154	Nut	M4	2	200	Eccentric Shaft		2
155	Hex. Cap Bolt	M10x25	2	201	Ball Bearing	608ZZ	8
156	Spring Washer	M10	2	202	Blade Guide		2
157	Washer		2	203	Hex. Socket Cap Screw	M6x25	2
158	Drive Flywheel		1	204	E Ring	E-7	4
159	Hex. Socket Cap Screw	M10x40	4	205	Centric Shaft		2
160	Spring Washer	M10	4	206	Ball Bearing	608ZZ	2
161	Hose	5/16x90cm	1				
162	Pipe Fitting	1/4Px5/16	2				
163A	T Connector		1				
164	Hex. Socket Cap Screw	M5x16	2				
165	Coolant Switch	1/4Px5/16	1				

1071101

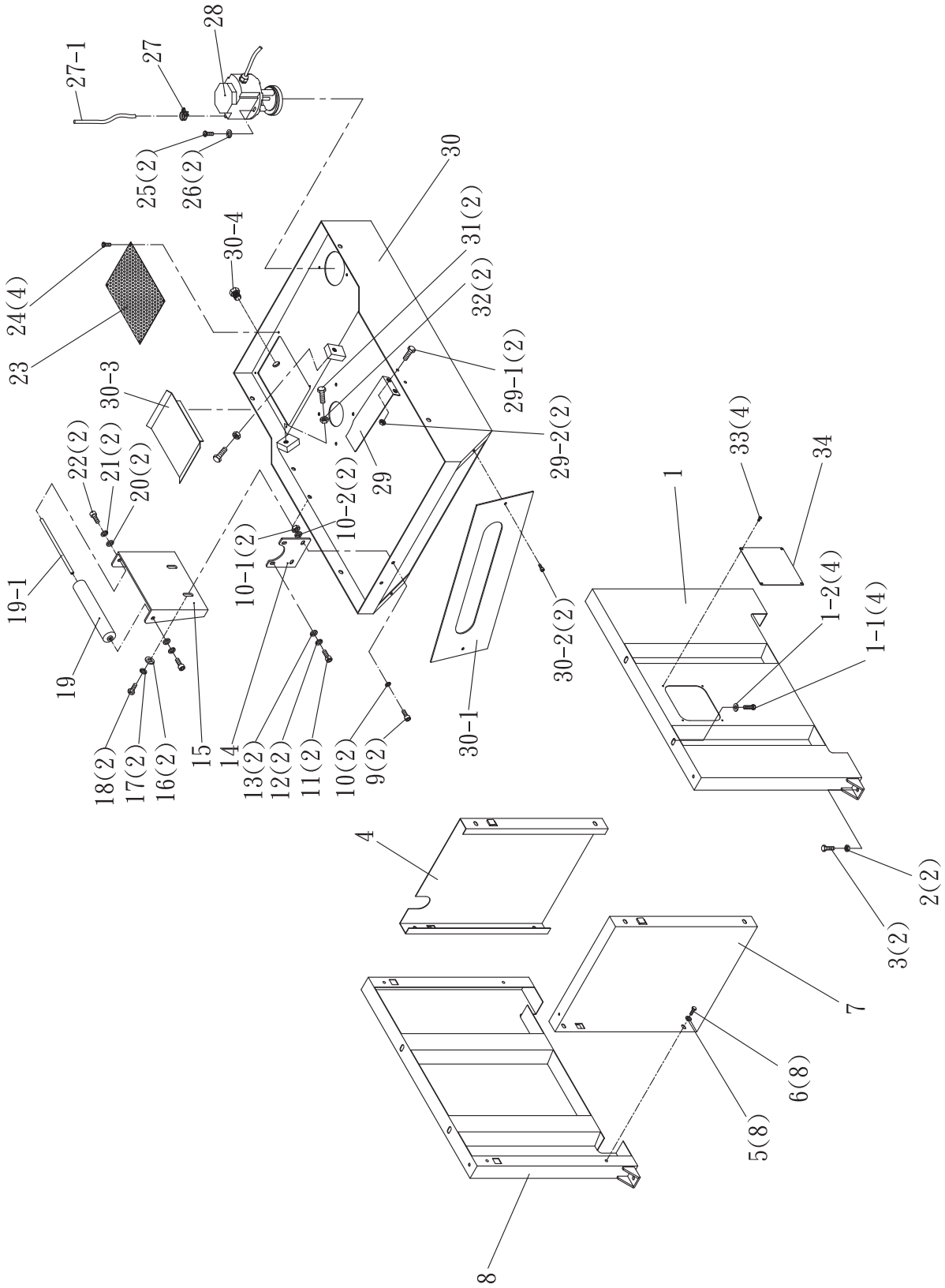

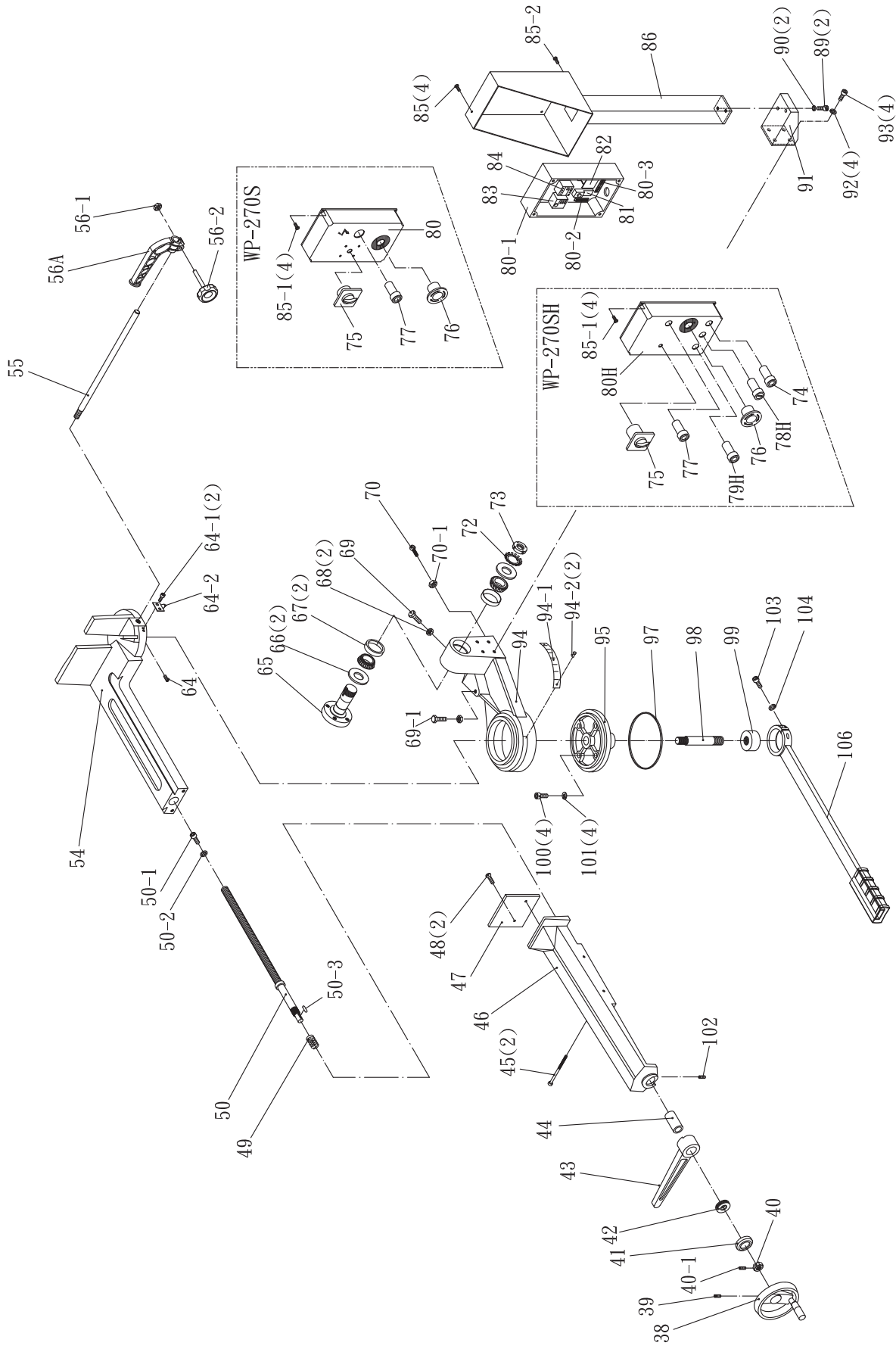

WP-270S/SH

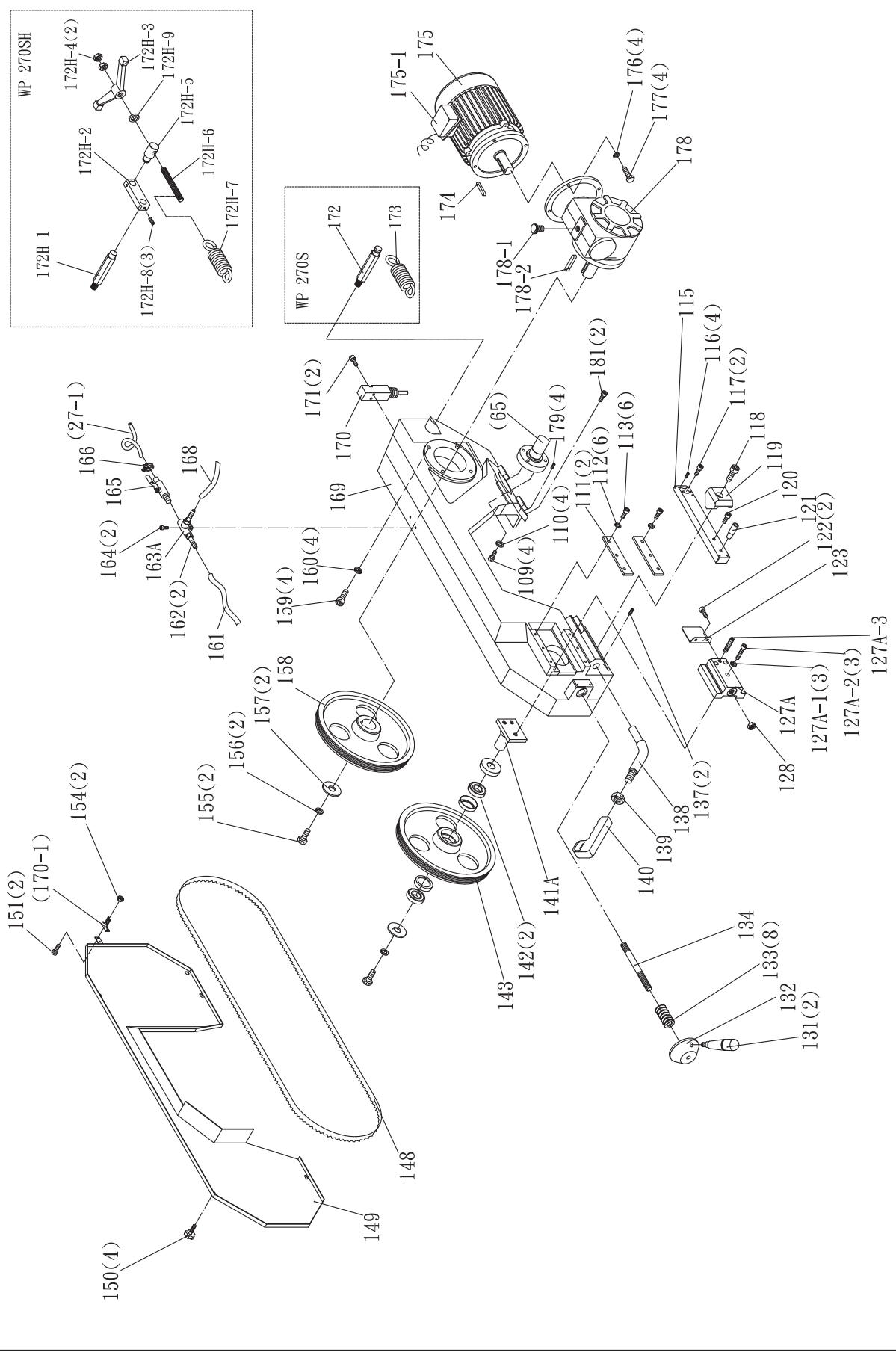

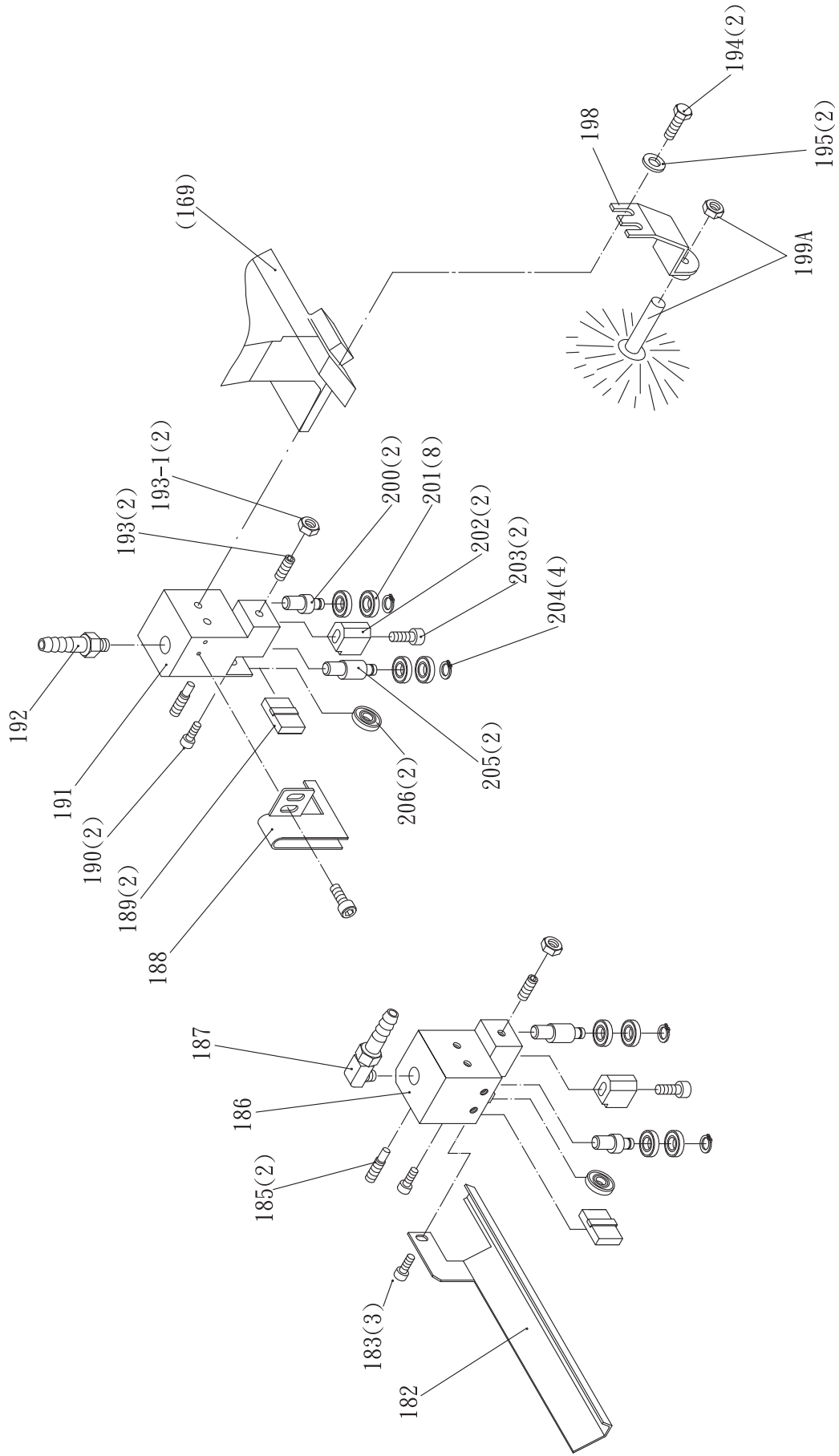

WP-270SH

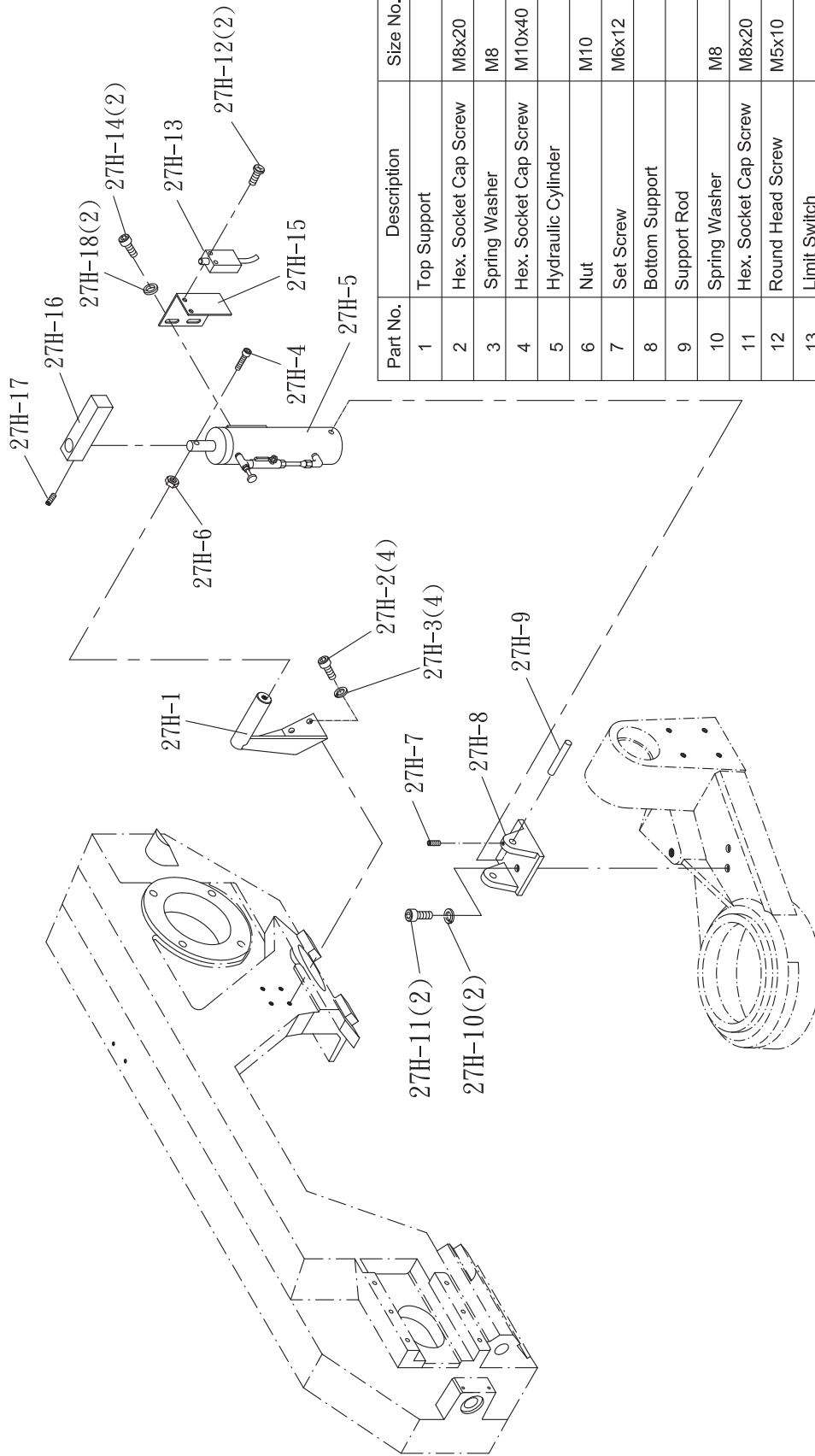

Part No.	Description	Size No.	Q'ty
1	Top Support		1
2	Hex. Socket Cap Screw	M8x20	4
3	Spring Washer	M8	4
4	Hex. Socket Cap Screw	M10x40	1
5	Hydraulic Cylinder		1
6	Nut	M10	1
7	Set Screw	M6x12	1
8	Bottom Support		1
9	Support Rod		1
10	Spring Washer	M8	2
11	Hex. Socket Cap Screw	M8x20	2
12	Round Head Screw	M5x10	2
13	Limit Switch		1
14	Hex. Socket Cap Screw	M6x8	2
15	Adjusting Bracket		1
16	Setting Bracket		1
17	Set Screw	M6x12	1
18	Washer	6x13x1	2

1011001-V2