

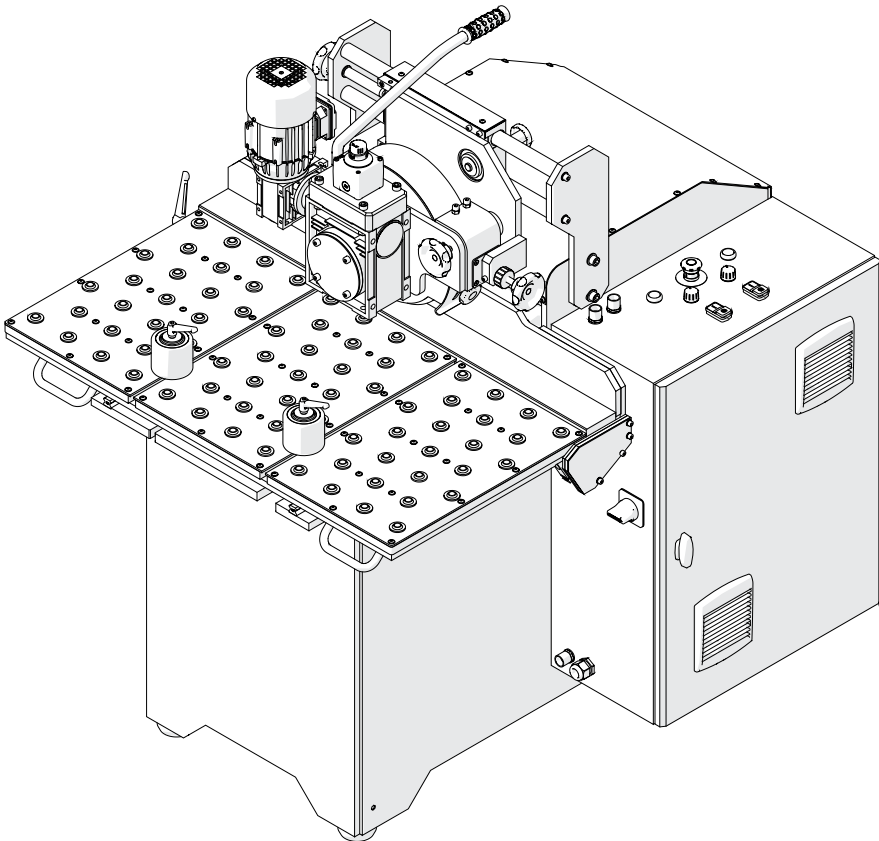

SBM-500 STATIONARY BEVELLING MACHINE

OPERATOR'S MANUAL



PART NO. WA-SBM500

Ver: 1.0

www.itmtools.com.au

Contents

1. GENERAL INFORMATION	3
1.1. Application	3
1.2. Technical data.....	3
1.3. Equipment included	4
1.4. Dimensions	5
1.1. Design	6
2. SAFETY PRECAUTIONS.....	7
3. STARTUP AND OPERATION	9
3.1. Preparing	9
3.2. Setting the table and the feed unit.....	12
3.3. Setting the bevel angle and milling head penetration	13
3.4. Setting the feed wheel height	17
3.5. Tilting the feed unit.....	18
3.6. Adjusting the feed wheel	19
3.7. Operating	20
3.8. Removing and installing the milling head	22
3.9. Replacing the cutting inserts	23
4. ACCESSORIES	24
4.1. Pipe attachment	24
4.2. Cutting tools.....	26
4.3. Table.....	27
4.4. Attachment for narrow plates	28

1. GENERAL INFORMATION

1.1. Application

The SBM-500 is a stationary machine designed to bevel plates made of carbon steel, stainless steel, or aluminum alloys. The workpieces can be machined at an angle of 15–60° and to the bevel width of up to 30 mm (1-3/16").

Accessories allow bevelling pipes with outer diameters of 50–150 mm (2–6") and bevelling long plates and narrow plates.

1.2. Technical data

Voltage	3~ 400V + PE, 50/60 Hz
Power	8 kVA
Spindle rotational speed (without load)	500–2920 rpm
Feed wheel rotational speed	0.2–3.5 rpm
Feed speed	0.2–3.3 m/min
Table load capacity	100 kg (220 lbs)
Bevel angle (β , Fig. 1)	15–60°
Maximum bevel width (b , Fig. 1)	30 mm (1-3/16")
Maximum milling head penetration (d , Fig. 1) allowed per a single pass	4 mm (5/32")
Workpiece thickness	3–100 mm (1/8–4")
Minimum workpiece length	150 mm (6")
Minimum workpiece width	50 mm (2")
Protection level	IP 20
Protection class	I
Required ambient temperature	0–40 °C (34–104 °F)
Weight	865 kg (1910 lbs)

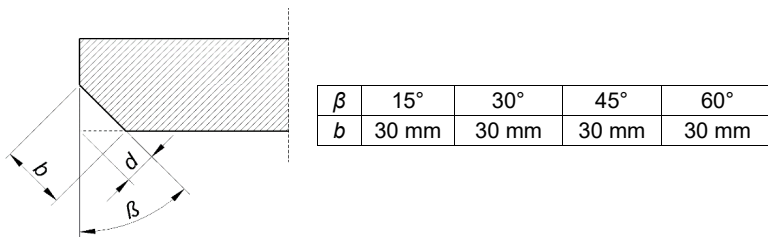
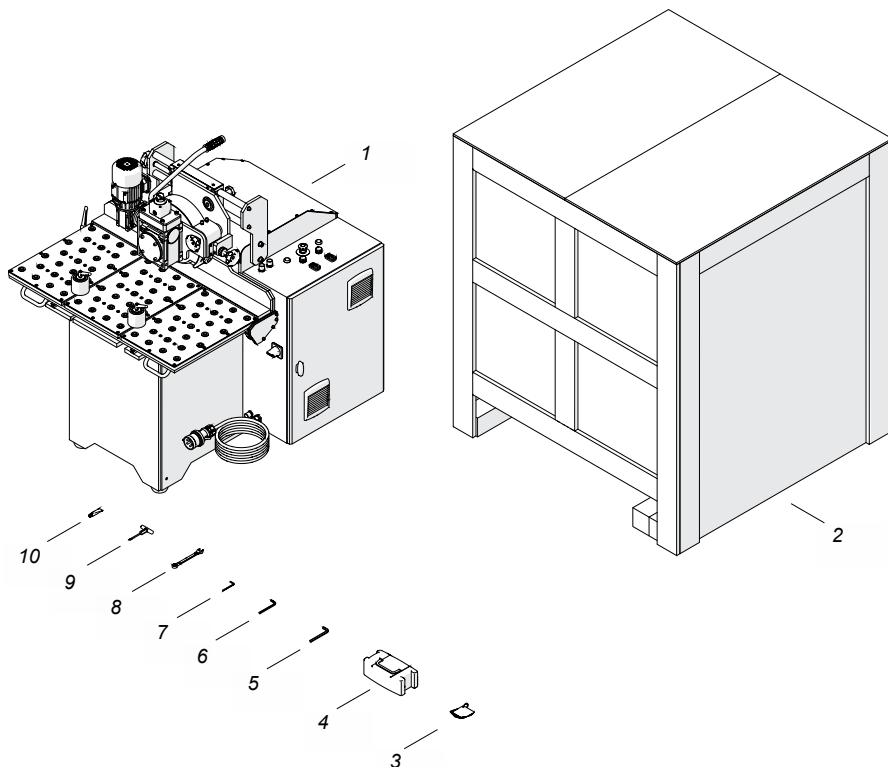

Fig. 1. Bevel dimensions; maximum bevel width depending on the angle

1.3. Equipment included



1	Stationary beveling machine (includes milling head with 10 cutting inserts)	1 unit
2	Wooden box with base and mounting brackets	1 unit
3	Bevel height gauges	1 set
4	Tool box	1 unit
5	8 mm hex wrench	1 unit
6	6 mm hex wrench	1 unit
7	3.5 mm hex wrench	1 unit
8	14 mm combination wrench	1 unit
9	T15 torx screwdriver	1 unit
10	Grease for screws	1 unit
-	Operator's manual	1 unit

1.4. Dimensions

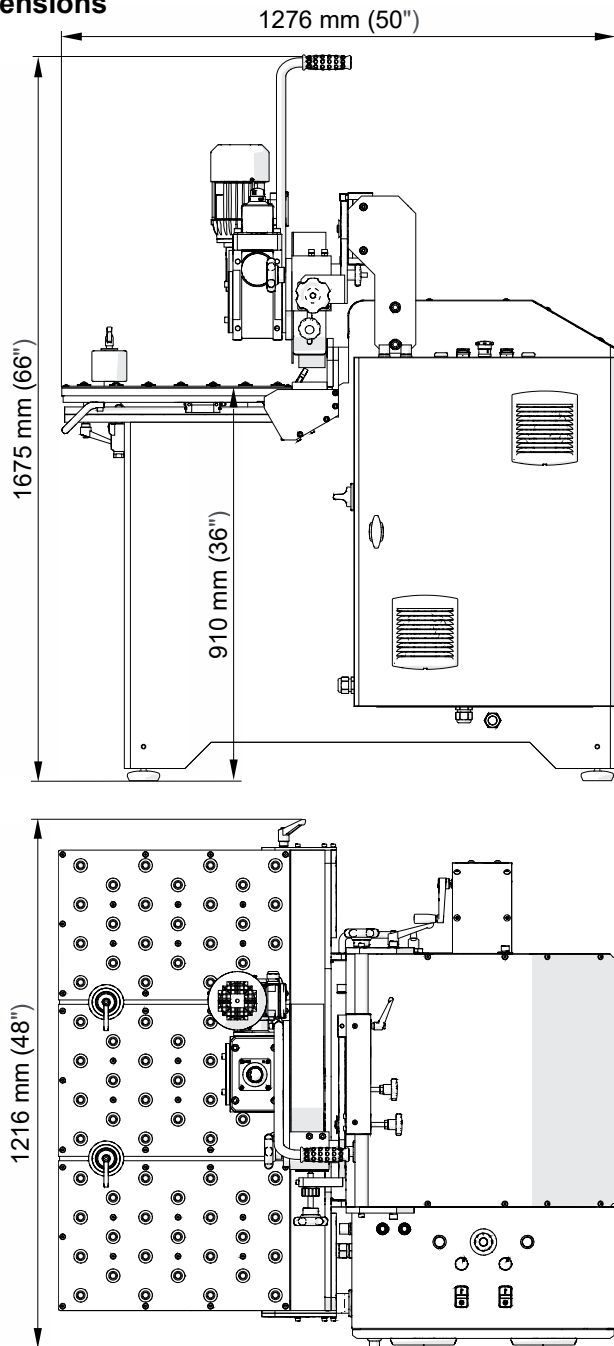

1.1. Design

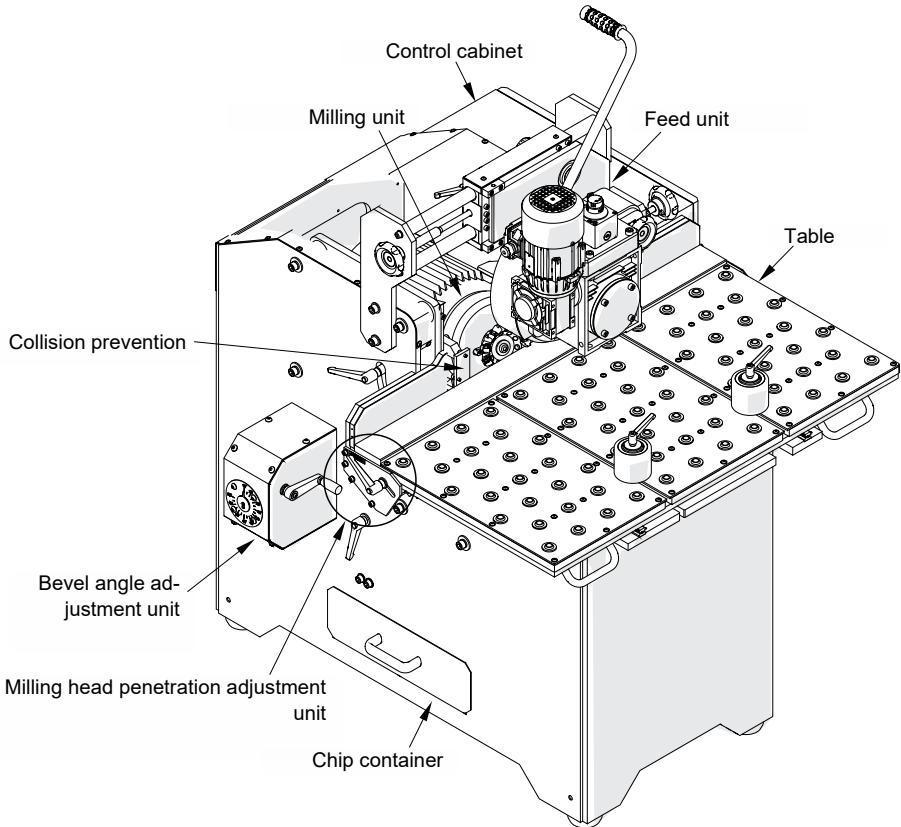

2. SAFETY PRECAUTIONS

1. Before use, read this Operator's Manual and complete a training in occupational safety and health.
2. Use only in applications specified in this Operator's Manual.
3. Make sure that the machine has all parts and they are genuine and not damaged.
4. Make sure that the specifications of the power source are the same as those specified on the rating plate.
5. Connect the machine to a 3×400 V + PE power source. Protect the power source with a 25 A three-phase slow-blow fuse. If you use a residual-current circuit breaker, it must be of type B and of value of at least 300 mA.
6. Do not pull the cord. This can cause damage and electric shock.
7. Keep the machine in vertical position during transport and work.
8. Put the machine on a surface that ensures balance and efficiently transfers the loads of the machine and workpiece. An incorrectly prepared surface may lead to damage, incorrect machine work, and injuries to persons nearby.
9. Keep untrained bystanders away from the machine.
10. Before each use, ensure the correct condition of the machine, power source, power cord, plug, control panel, and tools.
11. Before each use, make sure that no part is cracked or loose. Make sure to maintain correct conditions that can have an effect on the operation of the machine.
12. After the power is off, wait 3 minutes before you open the control cabinet.
13. After the power is off, wait 60 seconds before you turn the power on again.
14. Do not let chips get inside the control cabinet. Chips in the cabinet can cause damage to the machine.
15. Keep the machine dry. Do not expose the machine to rain, snow, or frost.
16. Keep the worksite well-lit, clean, and free of obstacles.
17. Make sure that the cutting inserts and the milling head are correctly attached. Remove wrenches from the worksite before you connect the machine to the power source.
18. Do not use tools that are dull or damaged.
19. If the cutting edge of an insert is worn, turn all inserts by 90°. If all edges are worn, install new inserts specified in this Operator's Manual.

20. Do not make bevels or use workpieces whose parameters differ from those specified in the technical data.
21. Do not use near flammable materials or in explosive environments.
22. Always use the feed wheel during work.
23. Use eye protection, ear protection, gloves, and protective clothing. Do not use loose clothing.
24. Do not touch chips or moving parts. Do not let anything catch in moving parts. Do not put hands under the feed wheel.
25. After each use, clean the machine and the milling head with a cotton cloth and no chemical agents. Do not remove chips with bare hands.
26. Maintain the machine and install/remove parts and tools only after you unplug the machine from the power source.
27. Repair only in a service center appointed by the seller.
28. If the machine is wet or has any damage, stop the work and promptly send the machine to the service center for check and repair.
29. Do not leave the machine when it operates.
30. If you are not going to use the machine for an extended period, put anti-corrosion material on the steel parts.

3. STARTUP AND OPERATION

3.1. Preparing

Use the 6 mm hex wrench to tighten the handle (1, Fig. 2). Then, use the 8 mm hex wrench to detach the machine from the brackets (2).

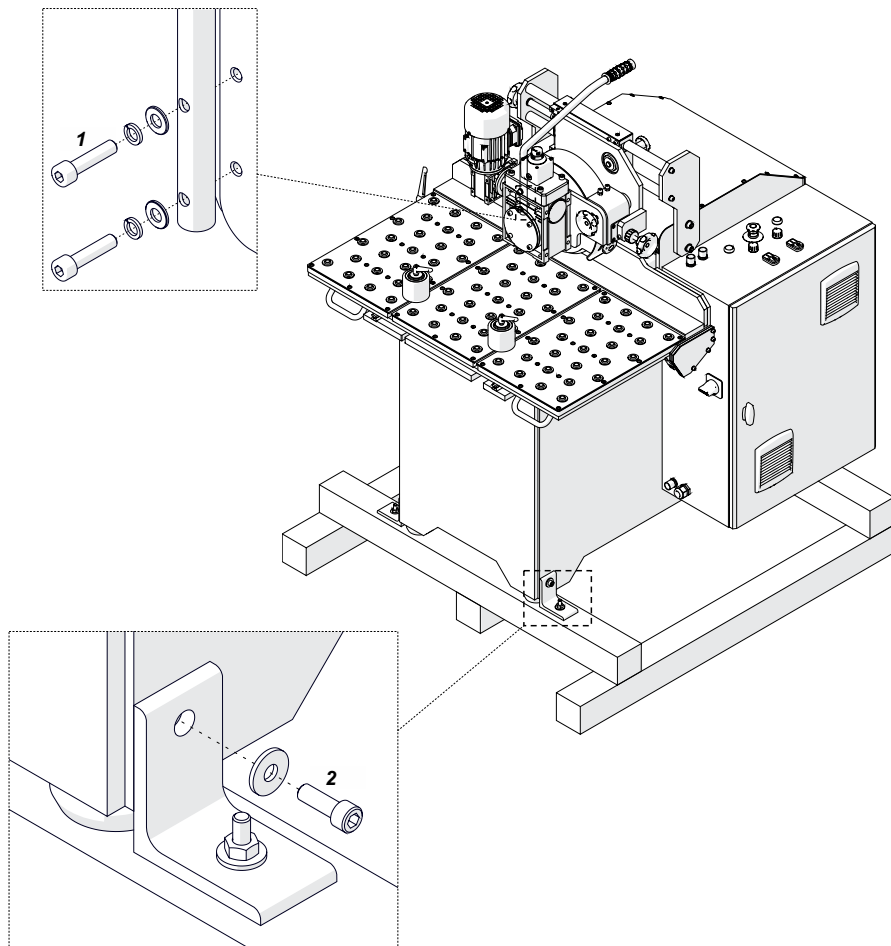

Fig. 2. Installing the handle and detaching the machine from the base

Use a pallet jack to lift the machine from left or right (Fig. 3), and then transport it to the worksite.

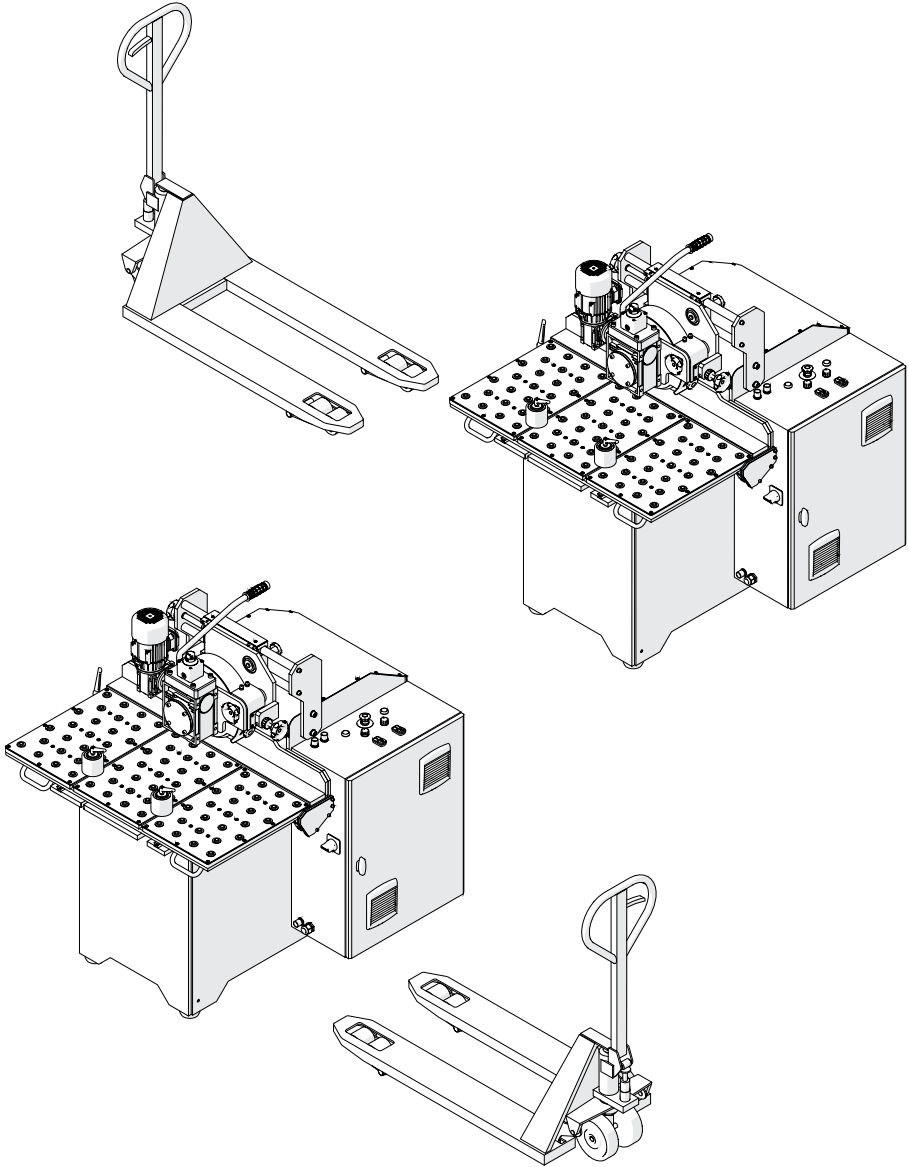

Fig. 3. Transporting the machine to the worksite

Put the machine on a surface that ensures balance and efficiently transfers the loads of the machine and workpiece. Turn the feet that are not in contact with the surface so that they rest on it (1, Fig. 4). Then, use the 18 mm flat wrench to tighten the nuts, which will lock the feet in this position.

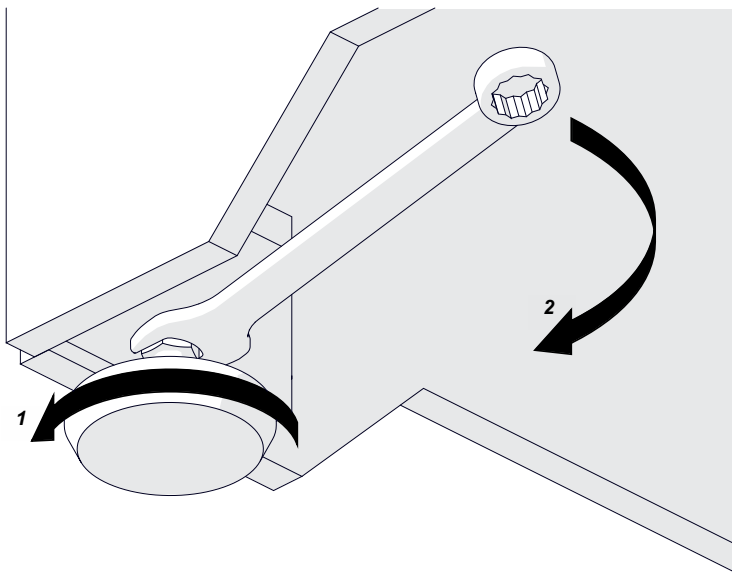

Fig. 4. Levelling the machine on the surface

3.2. Setting the table and the feed unit

Move the table forward so that it touches the bolt (1, Fig. 5), and then use the lever (2) to lock the table in this position. Next, use the handle (3) to turn the feed unit so that the screw makes contact with the bumper (4).

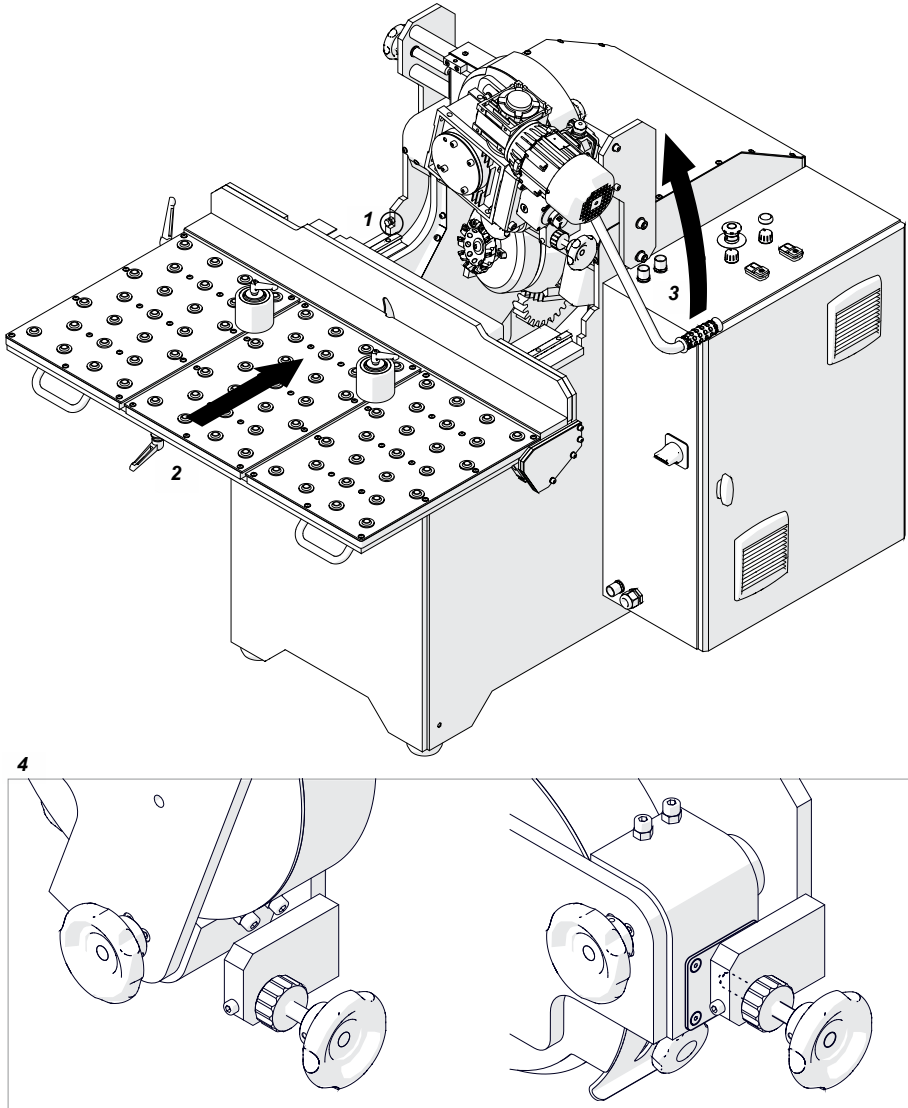

Fig. 5. Moving the table and lowering the feed unit

3.3. Setting the bevel angle and milling head penetration

First, set the penetration of the milling head to zero. If there is a gap between the vertical base (1) and horizontal base (2, Fig. 6a), unlock the lever (3). Then, turn the knob (4) so that the vertical base comes in contact with the horizontal base (Fig. 6b). Lock the lever in this position.

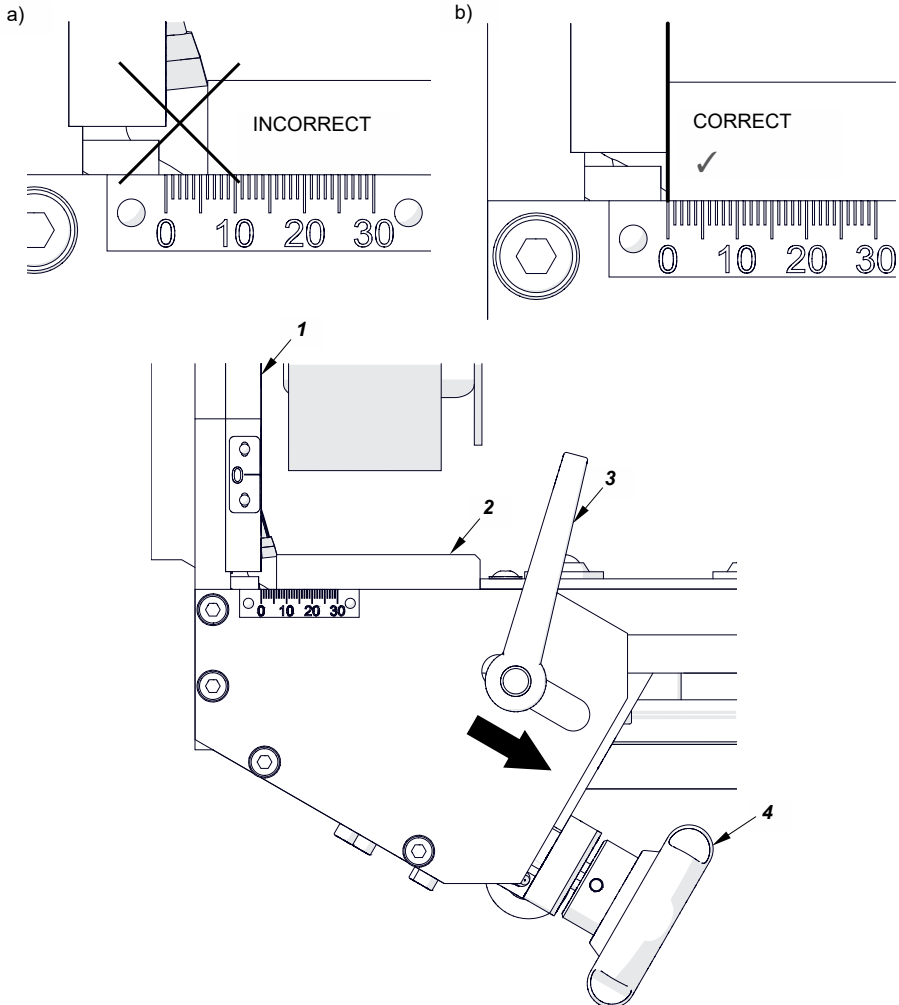

Fig. 6. Setting the milling head penetration to zero: incorrect (a), correct (b)

To set the bevel angle (Fig. 7), unlock the levers (1). Then, use the crank (2) to turn the milling unit so that the scale (3) shows the required angle. Lock the levers in this position.

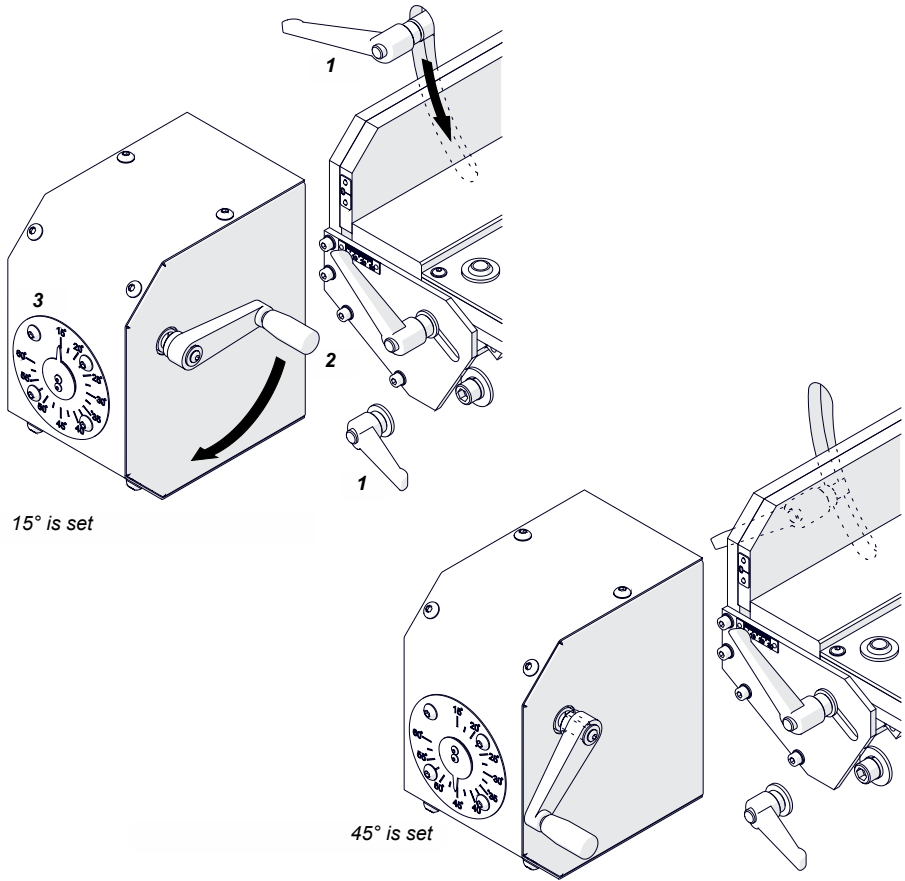

Fig. 7. Setting the bevel angle

Before the first pass, move the vertical base (1) away from horizontal base (2, Fig. 8). To do this, unlock the lever (3), and then use the knob (4) to move the vertical base to a gap (X) that is correct for a single pass.

		β	15°	20°	25°	30°	35°	40°	45°	50°	55°	60°		
Maximum allowed gap X [mm]	a [mm]	30											4 passes	
		29												
		28												
		27												15.6
		26												15.0
		25										17.5		14.4
		24									20.1	16.8	13.9	3 passes
		23									19.3	16.1	13.3	
		22								22	18.5	15.4	12.7	
		21								21	17.6	14.7	12.1	
		20							23.8	20	16.8	14.0	11.6	
		19							22.6	19	15.9	13.3	11.0	
		18						25.7	21.5	18	15.1	12.6	10.4	2 passes
		17						24.3	20.3	17	14.3	11.9	9.8	
		16					27.7	22.9	19.1	16	13.4	11.2	9.2	
		15					26.0	21.4	17.9	15	12.6	10.5	8.7	
		14			30.0	24.3	20.0	16.7	14	11.8	9.8	8.1		
		13			27.9	22.5	18.6	15.5	13	10.9	9.1	7.5		
		12			25.7	20.8	17.1	14.3	12	10.1	8.4	6.9	1 pass	
		11		30.2	23.6	19.0	15.7	13.1	11	9.2	7.7	6.4		
10		27.5	21.5	17.3	14.3	11.9	10	8.4	7.0	5.8				
9	33.6	24.7	19.3	15.6	12.9	10.7	9	7.6	6.3	5.2				
8	29.9	22.0	17.2	13.9	11.4	9.5	8	6.7	5.6	4.6				
7	26.1	19.2	15.0	12.1	10.0	8.3	7	5.9	4.9	4.0				
6	22.4	16.5	12.9	10.4	8.6	7.2	6	5.0	4.2	3.5				
5	18.7	13.7	10.7	8.7	7.1	6.0	5	4.2	3.5	2.9				
4	14.9	11.0	8.6	6.9	5.7	4.8	4	3.4	2.8	2.3				
3	11.2	8.2	6.4	5.2	4.3	3.6	3	2.5	2.1	1.7				
2	7.5	5.5	4.3	3.5	2.9	2.4	2	1.7	1.4	1.2				
1	3.7	2.8	2.1	1.7	1.4	1.2	1	0.8	0.7	0.6				

Between the vertical base and the horizontal base, put the bevel height gauge that matches the angle. On the scale (5), read the bevel height 'a' for the gap. Make sure that the vertical base is not in contact with the milling head, and then lock the lever in this position.



If the vertical base is moved away too far, it may come in contact with the milling head and thus damage the machine. Do not exceed 4 mm (5/32") of the milling head penetration 'd' (Fig. 8) per a single pass. The table shows how far you can move the vertical base per a single pass not to exceed the penetration 'd' of 4 mm.

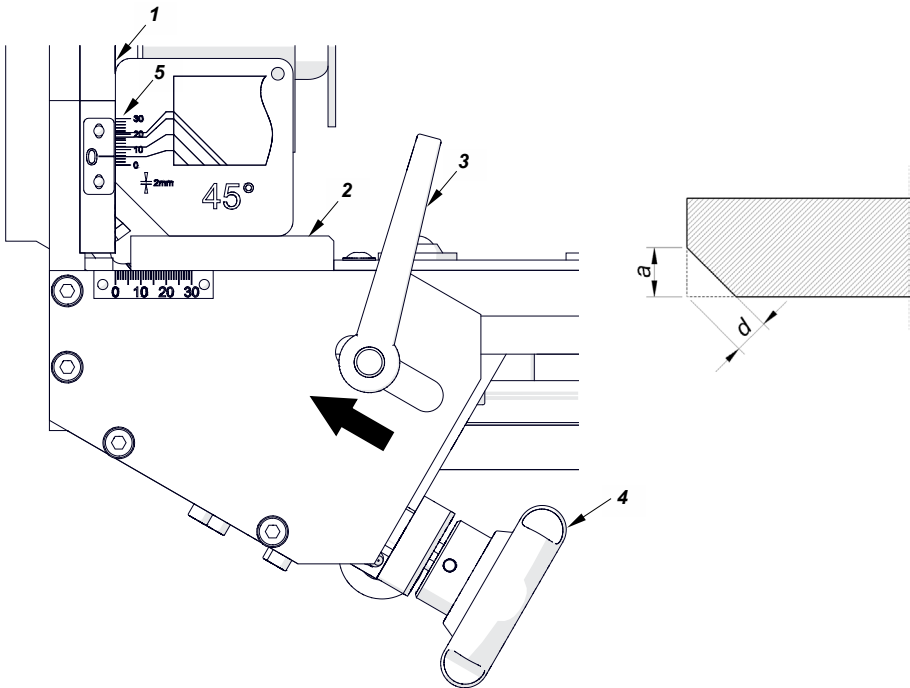

Angle	15°	20°	25°	30°	35°	40°	45°	50°	55°	60°
Maximum allowed gap-increase per a single pass [mm]	4	4	5	5	5	5	6	6	7	8

Fig. 8. Setting the milling head penetration before the first pass

3.4. Setting the feed wheel height

Use the knob (1, Fig. 9) to set the feed wheel at such a height so that the workpiece is firmly pressed to the horizontal base (2) during rotation of the feed wheel. Then, use the nut (3) to lock the knob in this position.

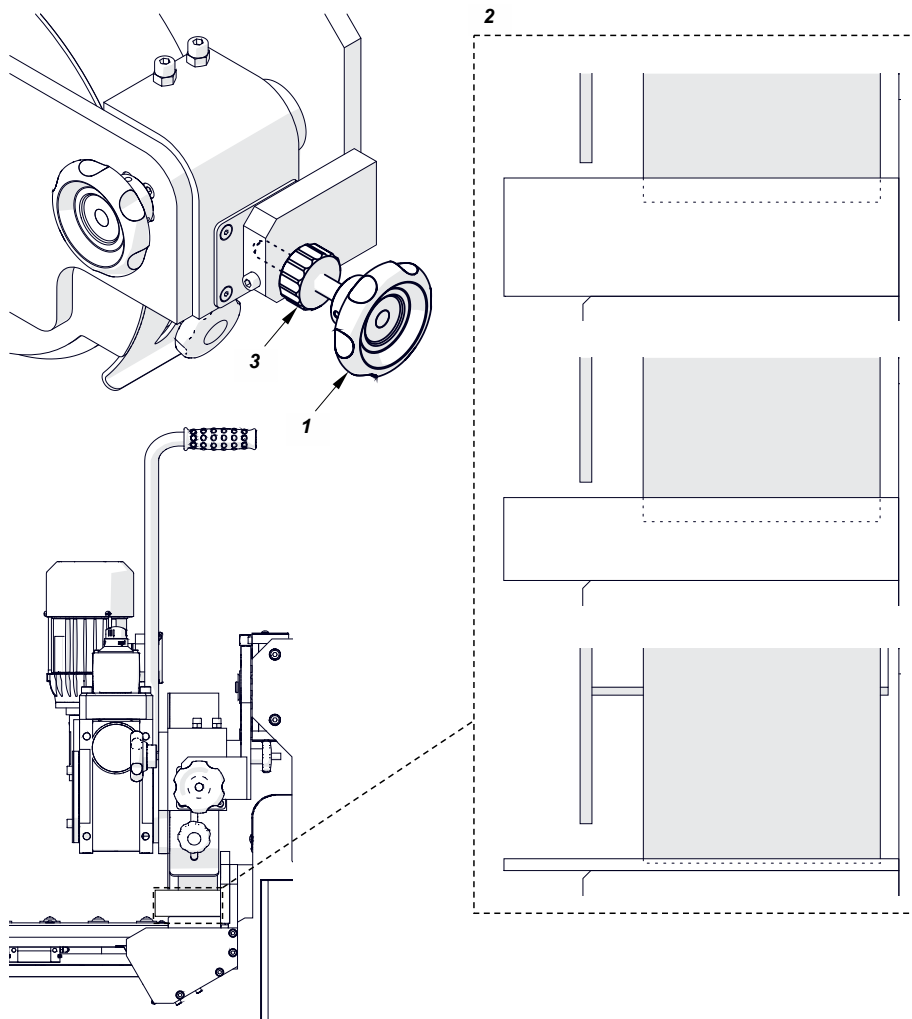

Fig. 9. Setting the feed wheel height

3.5. Tilting the feed unit

To ensure that the workpiece is sufficiently pressed to the vertical base, use the knobs (1, 2, Fig. 10) to tilt the feed unit. Do this when milling narrow workpieces or after moving the vertical base away from the horizontal base.

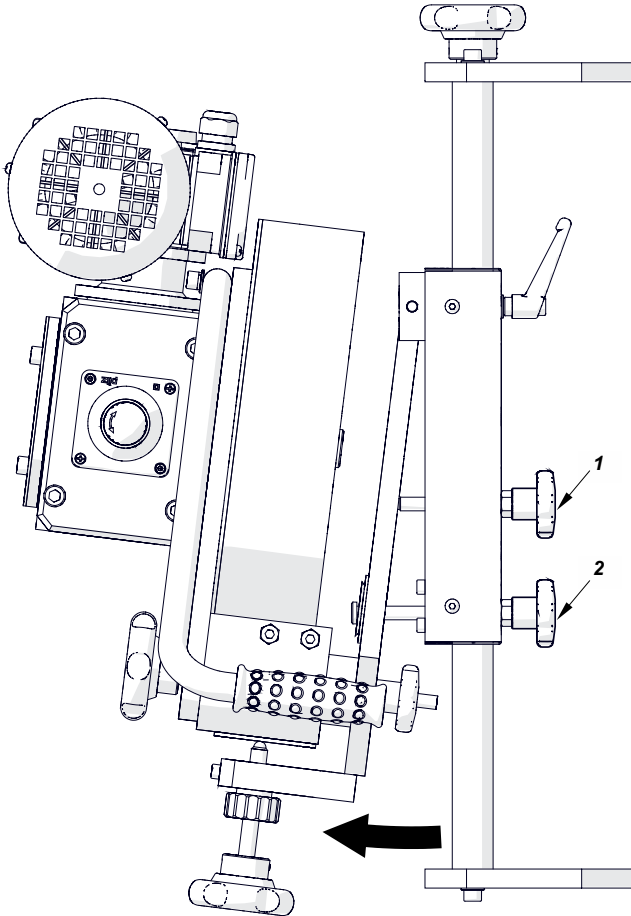

Fig. 10. Tilting the feed unit

Then, adjust the feed wheel.

3.6. Adjusting the feed wheel

Loosen the knob (1, Fig. 11) and lever (2). Then, use the knobs (3) and (4) to move the feed unit so that (5) the wheel comes as close to the milling spot as possible (6). Next, lock the knob (1) and lever (2) in this position. Do not let the feed wheel or its cover come in contact with the milling head or vertical base.

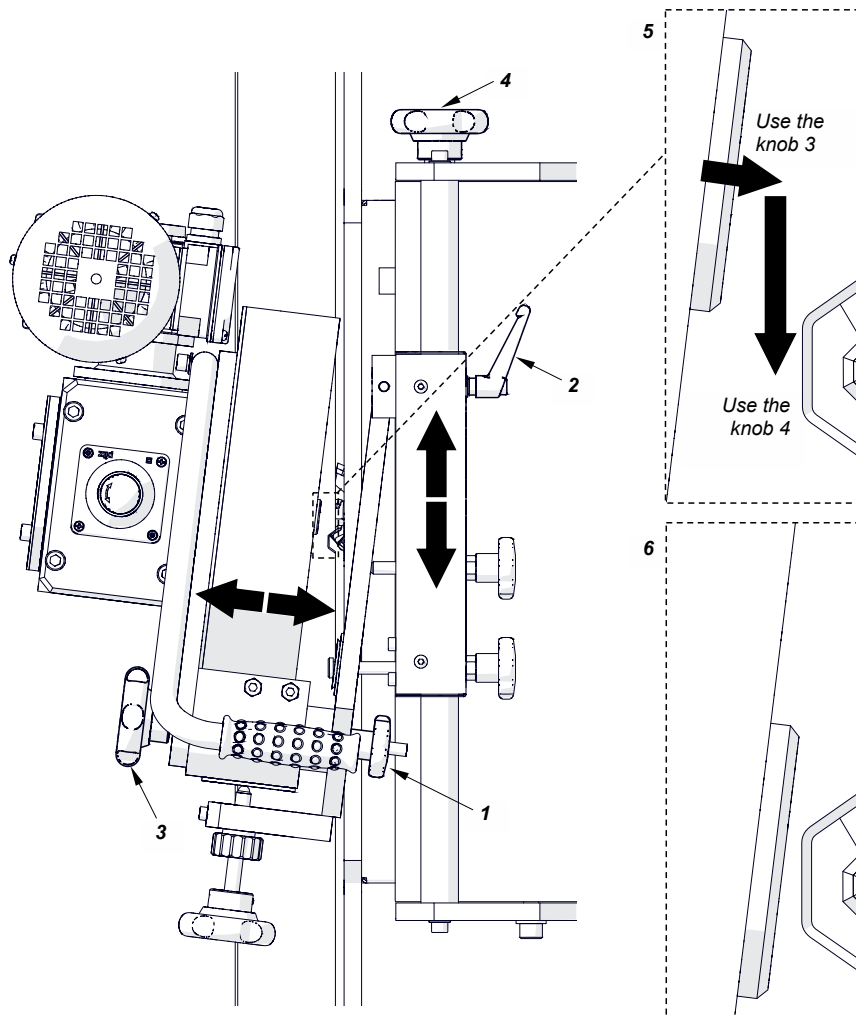

Fig. 11. Adjusting the feed wheel

3.7. Operating

Connect the machine to the power source and use the switch (1, Fig. 12) to turn on the power. On the control panel, press START, and then start the SPINDLE and FEED. Use knobs to set the required spindle speed and feed speed. Next, loosen the knob (2, Fig. 12), lower the chip guard (3). Tighten the knob in this position.

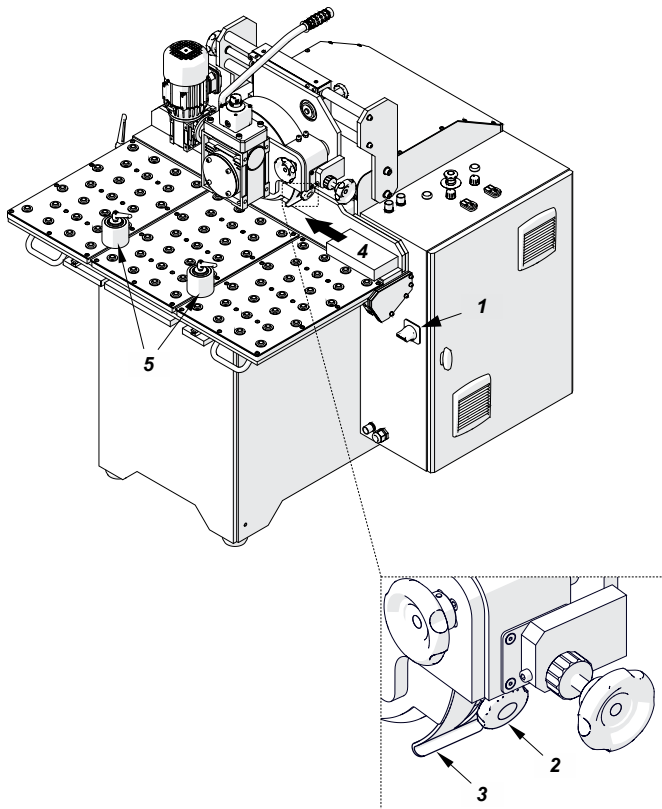

Fig. 12. Starting the work

Put the workpiece on the right side. Press the workpiece to the vertical and horizontal base and move it to the direction (4, Fig. 12) to put it under the feed wheel. After the first pass, move the vertical base away to get the correct gap for the next pass. Between the vertical base and the horizontal base, put the bevel height gauge related to the angle. On the gauge scale, read the bevel height related to the gap. Make sure that the vertical base is not in contact with the milling head.



If the vertical base is moved away too far, it may come in contact with the milling head and thus damage the machine. Do not exceed 4 mm (5/32") of the milling head penetration per a single pass. The table that follows shows how far you can move the vertical base per a single pass not to exceed the penetration of 4 mm.

Angle	15°	20°	25°	30°	35°	40°	45°	50°	55°	60°
Maximum allowed gap-increase per a single pass [mm]	4	4	5	5	5	5	6	6	7	8

To get better contact between the workpiece and the vertical base, use the rollers (5, Fig. 12) to press the workpiece.

Make several passes to get the required bevel parameters. Do not move the vertical base away to make the gap larger than specified in the table that follows.

Angle	15°	20°	25°	30°	35°	40°	45°	50°	55°	60°
Maximum allowed gap	9 mm	11 mm	14 mm	16 mm	18 mm	20 mm	22 mm	24 mm	25 mm	27 mm

To increase the life of the cutting inserts, move the vertical base away by a similar value in each pass. To get the best quality of the bevel, move the base away in the last pass as little as possible.

If the maximum allowed motor load is exceeded, the OVERLOAD button comes on. When this happens, lower the feed speed. If you continue operating when the motor is overloaded, the safety circuit will shut down the motor. To restart the machine in such a case, lift the feed unit and remove the workpiece. Then, press the OVERLOAD and then START.

In an emergency, press one of the emergency switches. To restart the machine, remove the cause of the emergency. Then, wait 60 seconds, unlock the switch, and press START.

After the power is off, wait 60 seconds before you turn the power on again.

If the table is moved back during work, the machine shuts down. To restart the operation, move the table forward as far as possible and press START.

Set the angle as described before only after you unplug the machine from the power source. Before you set the angle, set the penetration of the milling head to zero. If needed, tilt the feed unit and adjust the feed wheel.

Clean the machine with a cotton cloth and no chemical agents.

3.8. Removing and installing the milling head

Unplug the machine from the power source. Then, lift the feed unit (1, Fig. 13) and move the table back (2) to get access to the milling head. Use a 14 mm flat wrench to prevent the rotation of the spindle (3). Then, use the 8 mm hex wrench to remove the milling head (4).

To install, put the milling head on the spindle and prevent the rotation of the spindle. Then, use the removed screw and washer to tighten the milling head.

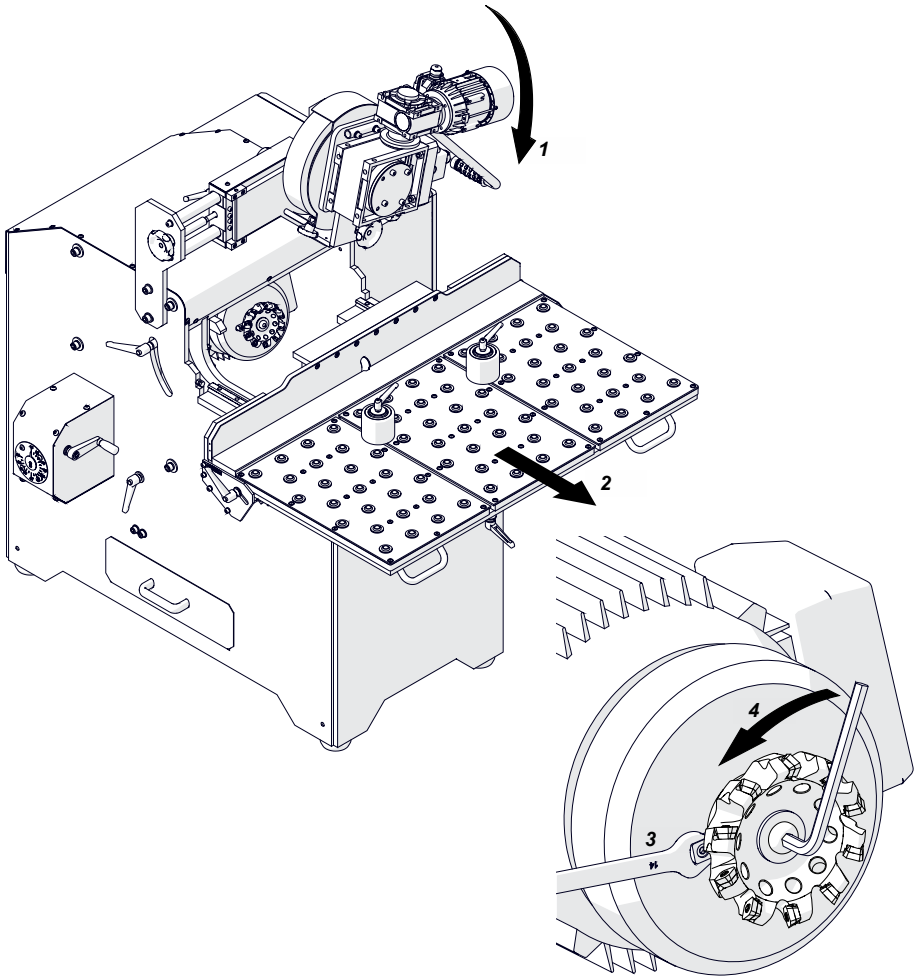

Fig. 13. Removing the milling head

3.9. Replacing the cutting inserts

Remove the milling head as described before and use the supplied screwdriver to remove the fixing screw (1, Fig. 14). Then, remove the cutting insert (2) and clean the shim (3). Turn the cutting insert by 90° and reinstall it or replace with a new insert if all four edges are worn. Press the cutting insert so that its bottom is in full contact with the shim, and then tighten with the fixing screw.

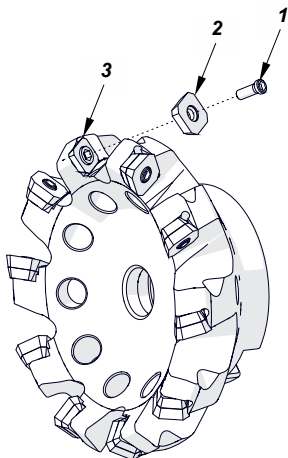

Fig. 14. Replacing the cutting inserts

4. ACCESSORIES

4.1. Pipe attachment

Allows the machine to bevel pipes with outer diameters of 50–150 mm (2–6”).

Part number:
PRK-0573-36-00-00-0

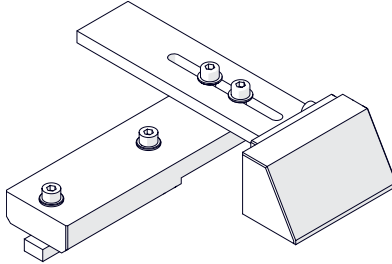

To install the attachment, set the milling head penetration to zero (Fig. 6b). Then, move the roller from the left groove to the right groove (1, Fig. 15). Next, lift the feed unit (2) and move the attachment into the left groove (3).

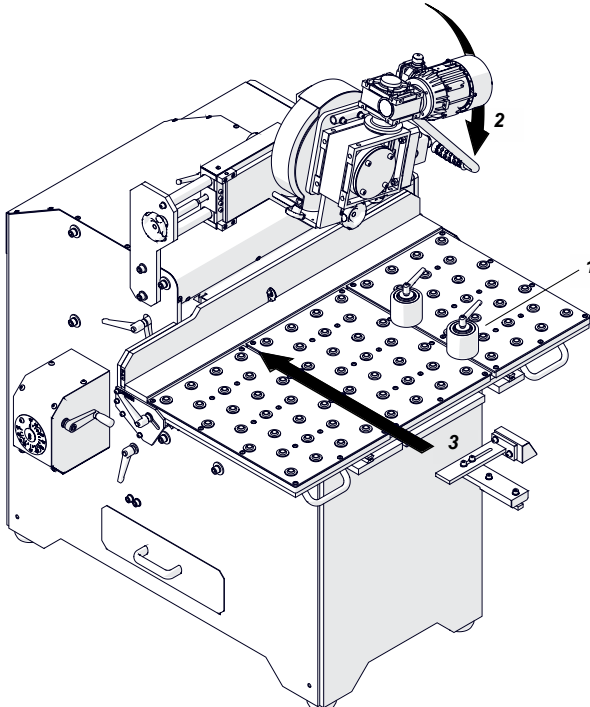

Fig. 15. Installing the pipe attachment

Make sure that the attachment is in contact with the vertical base and horizontal base. Then, use the 6 mm hex wrench to tighten the screws (1, 2, Fig. 16). Next, adjust the attachment so that (3) the bottom of the pipe is as close to the milling spot as possible (4) and tighten the screws (5).

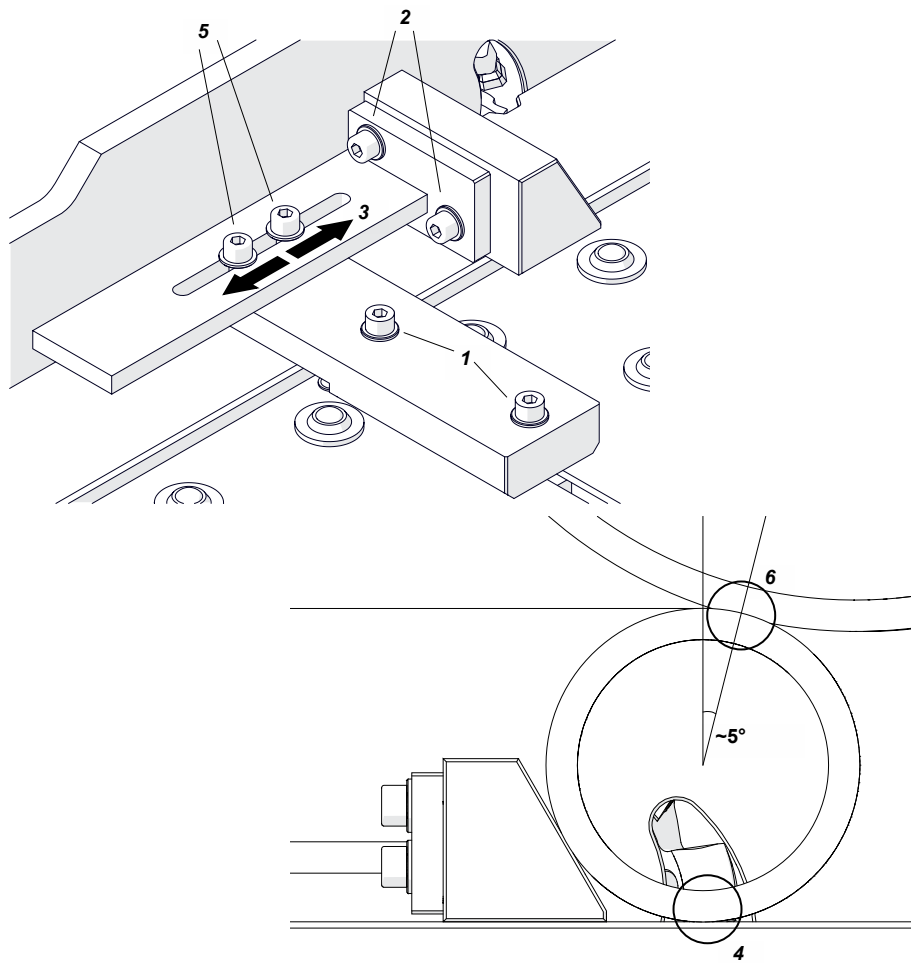

Fig. 16. Adjusting the attachment

Set the required bevel angle and milling head penetration (Fig. 6, 7, 8), and tilt the feed unit by about 2° (Fig. 10). Next, set the height feed wheel height and adjust the wheel (Fig. 9, 11) so that the pipe is pressed to the attachment and horizontal base when the feed wheel turns (6, Fig. 16).

Before you start the machine, move the pipe away from the milling head (Fig. 17). Do not make bevels with no root face (Fig. 17a). The root face must be at least 2 mm (1/16", Fig. 17b), and the bevel width must not be more than 15 mm (9/16").

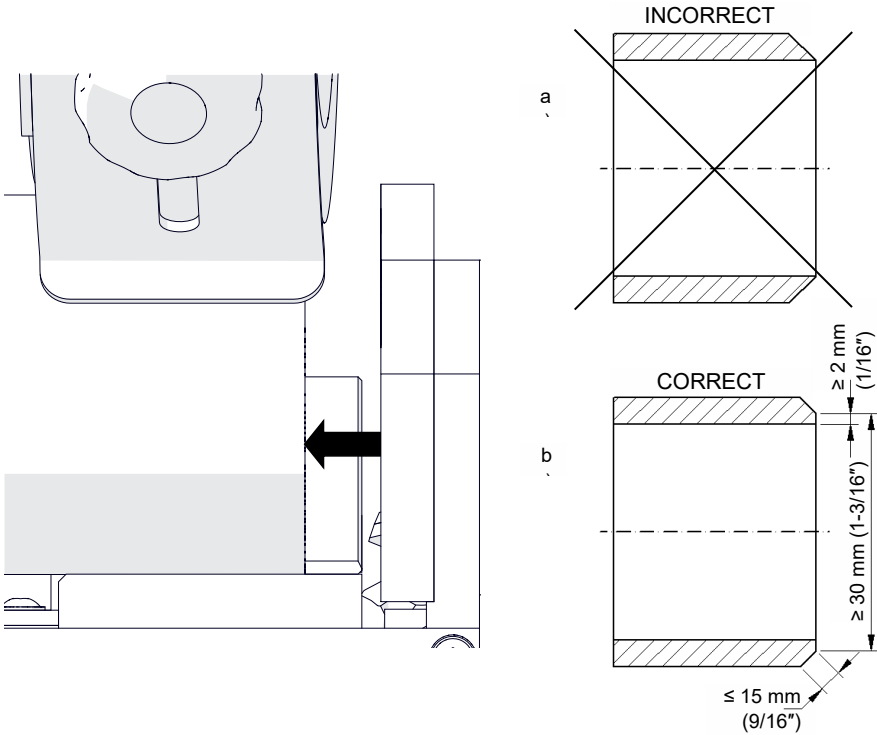

Fig. 17. Placing the pipe

After the machine starts, the feed wheel moves the pipe to the milling head.

4.2. Cutting tools

Part number	Part name
PLY-000396	Cutting insert for steel (10 required, sold 10 per box)
PLY-000408	Cutting insert for aluminum (10 required, sold 10 per box)

4.3. Table

Allows the machine to bevel longer plates.

Part number:
STL-0573-37-00-00

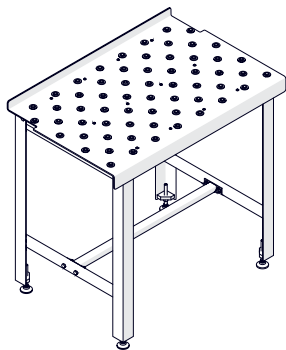

To assemble the table, put it upside down (Fig. 18). Use the 16 mm and 17 mm flat wrenches to attach the legs (1) and bracket (2).

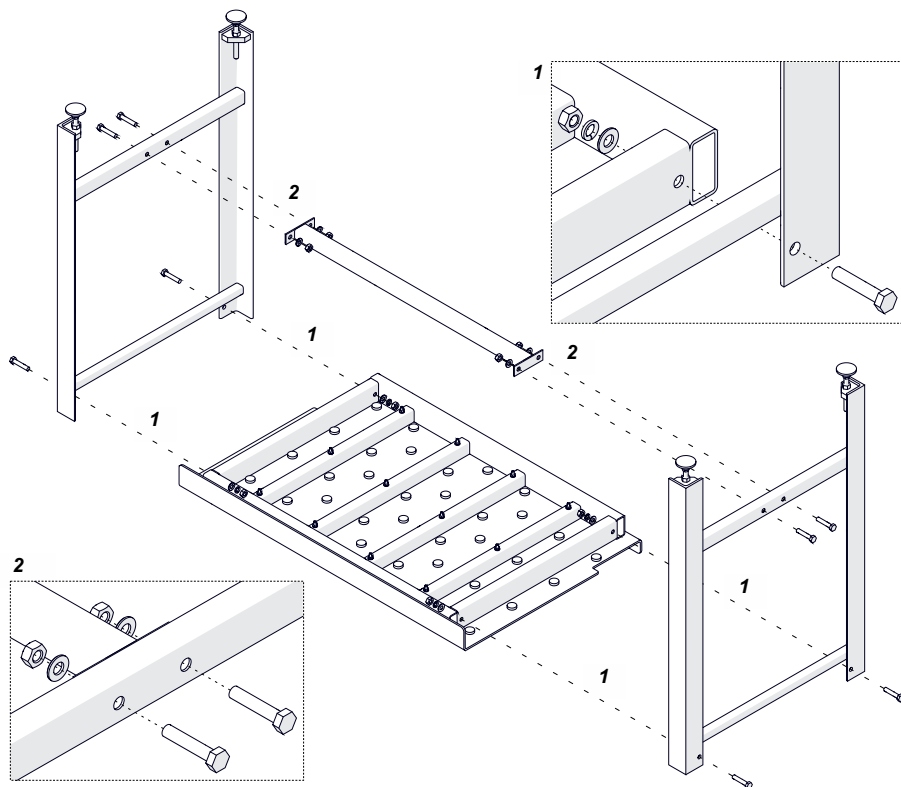

Fig. 18. Assembling the table

Use the 14 mm flat wrench to turn the feet (1, Fig. 18) so that the height of the tables is the same. Next, use the 18 mm flat wrench to tighten the nuts (2) to lock the feet in this position. Then, align the faces of the tables (3). Be careful not to catch your hands between the handle and table (4).

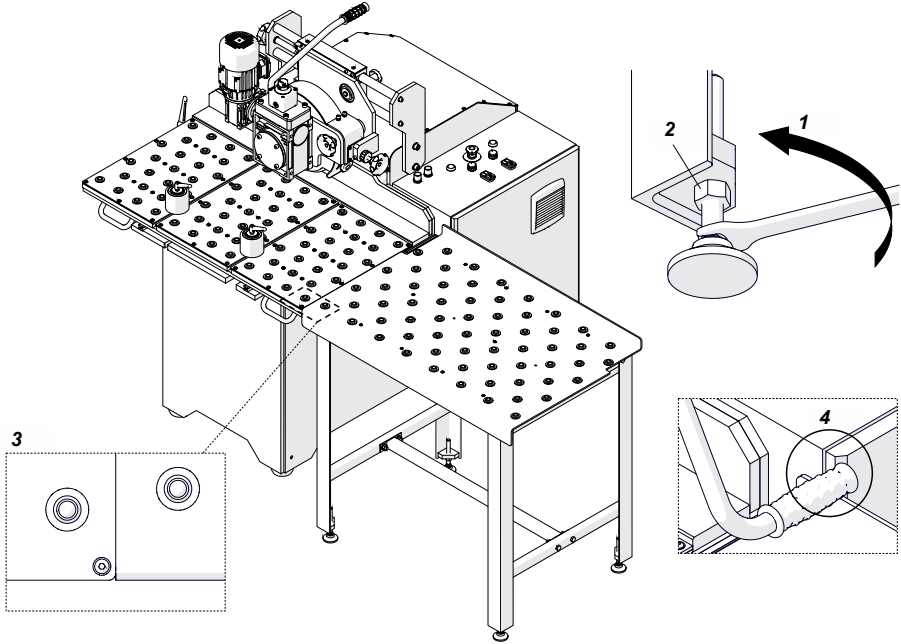

Fig. 19. Using the table

4.4. Attachment for narrow plates

Allows you to bevel plates with the width of at least 30 mm (1.18").

Part number:
PRK-0573-38-00-00

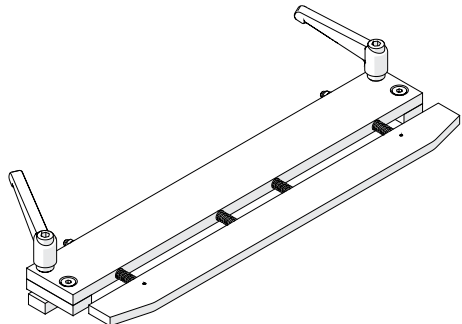
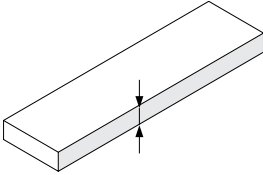
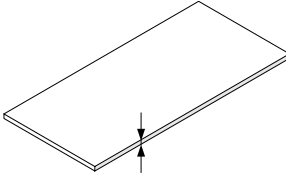

Plate width	Minimum allowed plate thickness	
30–50 mm (1.18–1.97")		10 mm (0.39")
≥ 50 mm (1.97")		3 mm (0.12")

To install the attachment, remove the rollers (1, Fig. 20) and move the attachment into the table grooves.

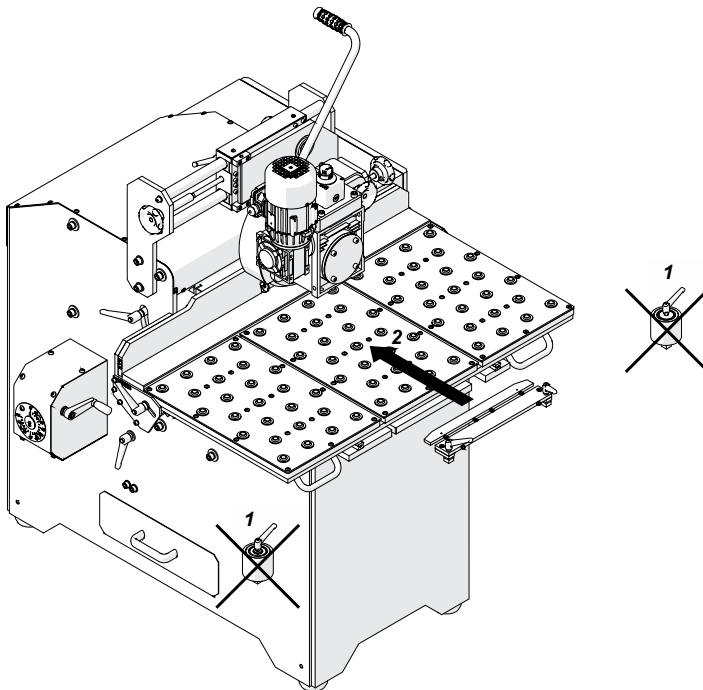

Fig. 20. Installing the attachment for narrow plates

Set the required bevel angle and milling head penetration (Fig. 6, 7, 8). Move the plate (3, Fig. 21) to the vertical base (4). Move the attachment to the plate (5) and lock the levers (6).

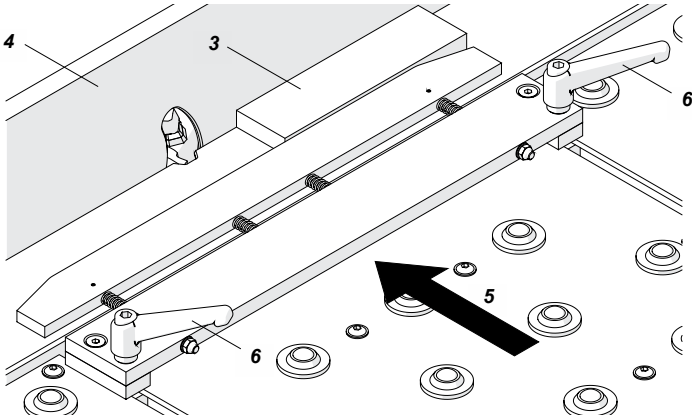
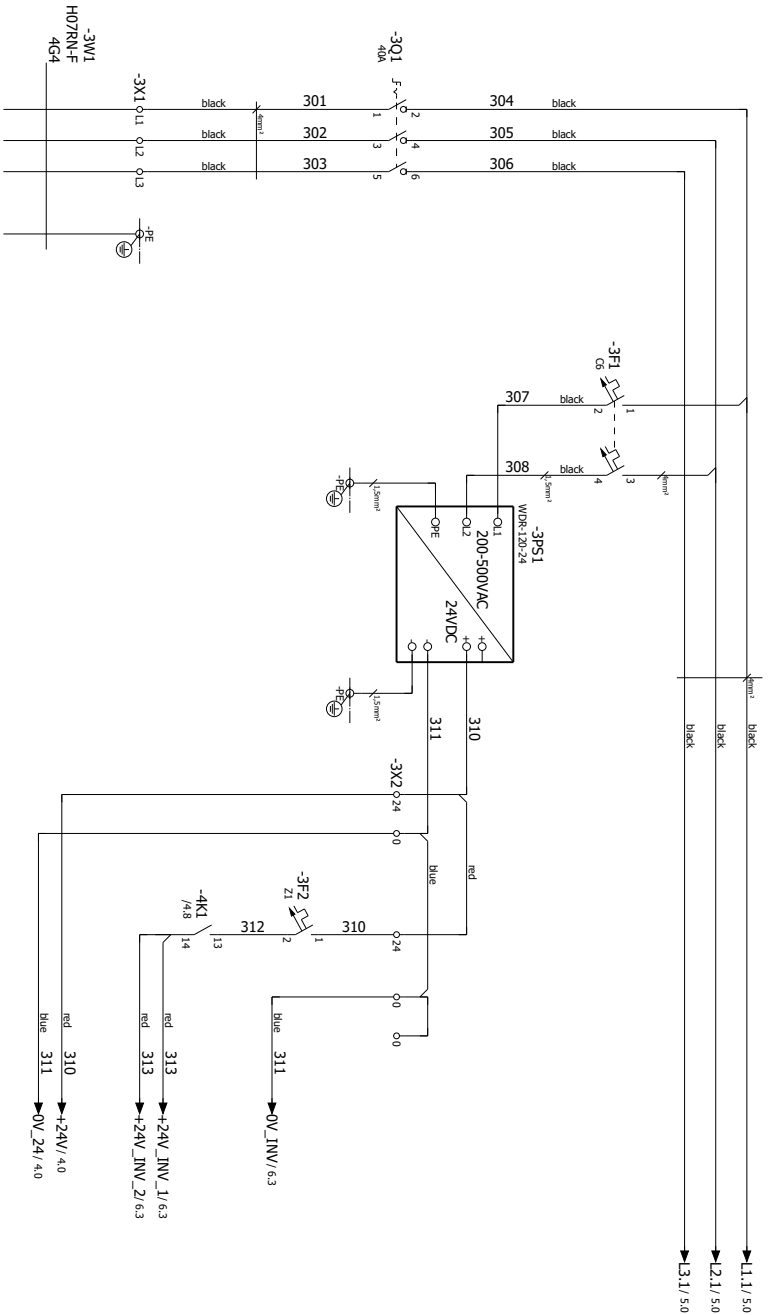
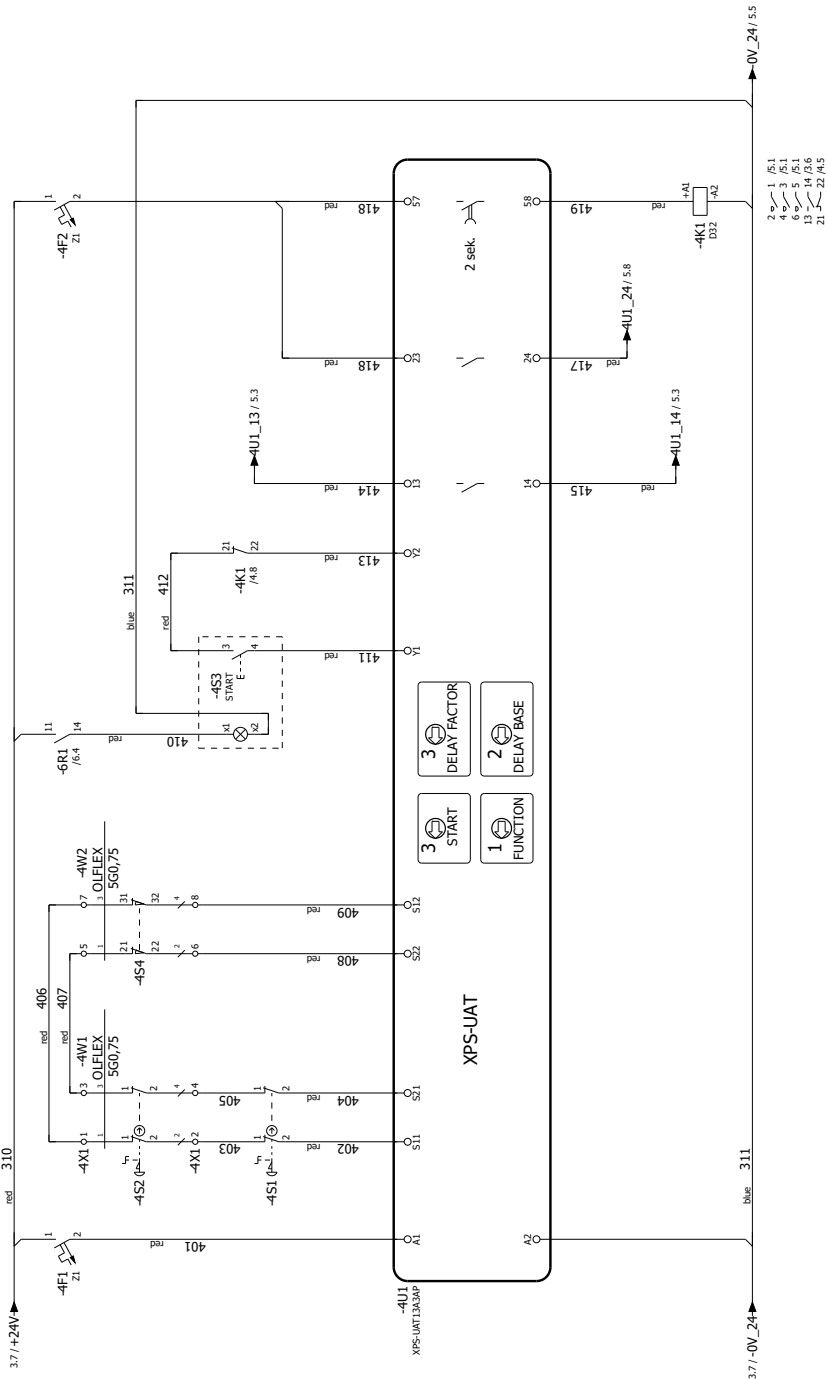

Fig. 21. Positioning the attachment



POWER SUPPLY
3x400V, 3x480V, 50/60 HZ, PE
 Use fuse or circuit breaker min. 25A with time delay characteristics

CONTROL BOX
 800X600X300
 Schneider Electric MCV/CPN5R/2P



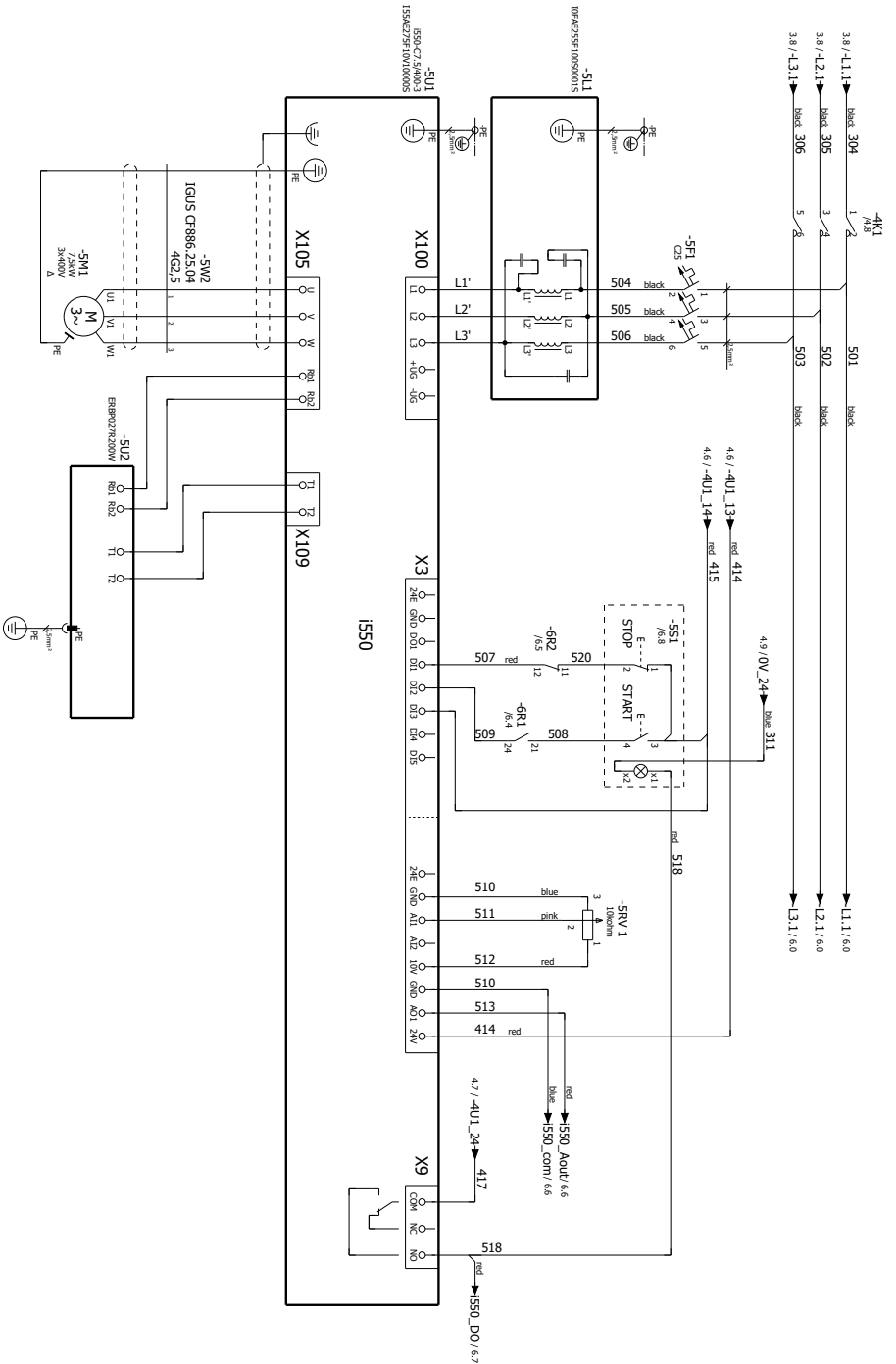

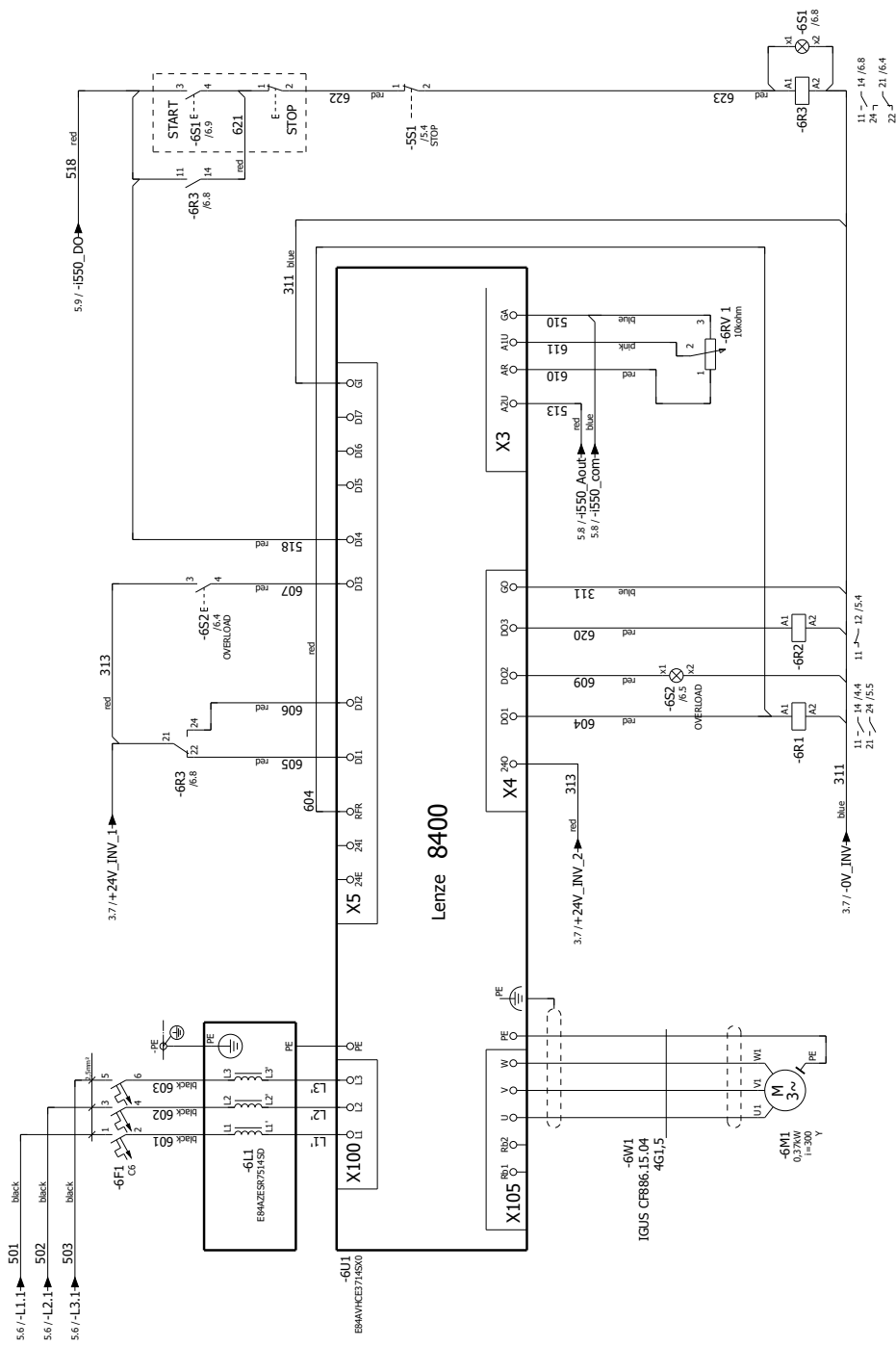

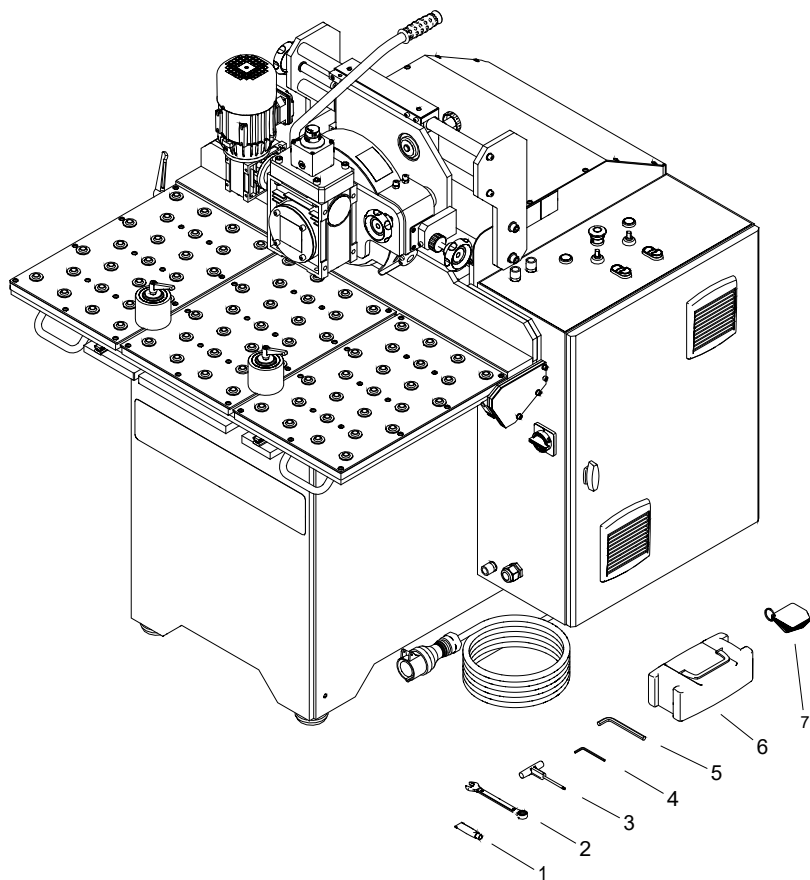

ITEM	PART NUMBER	DESCRIPTION	Q-TY
1	WAP-BM16/1110	GREASE FOR SCREWS 5g	1
2	KLC-000061	14 MM COMBINATION WRENCH	1
3	KLC-000066	T15 WRENCH WITH HANDLE	1
4	KLC-000065	3.5 MM HEX WRENCH	1
5	KLC-000011	8 MM HEX WRENCH	1
6	PJM-000010	TOOL CONTAINER	1
7	ZST-0573-42-00-00-0	BEVEL HEIGHT ADJUSTER	1

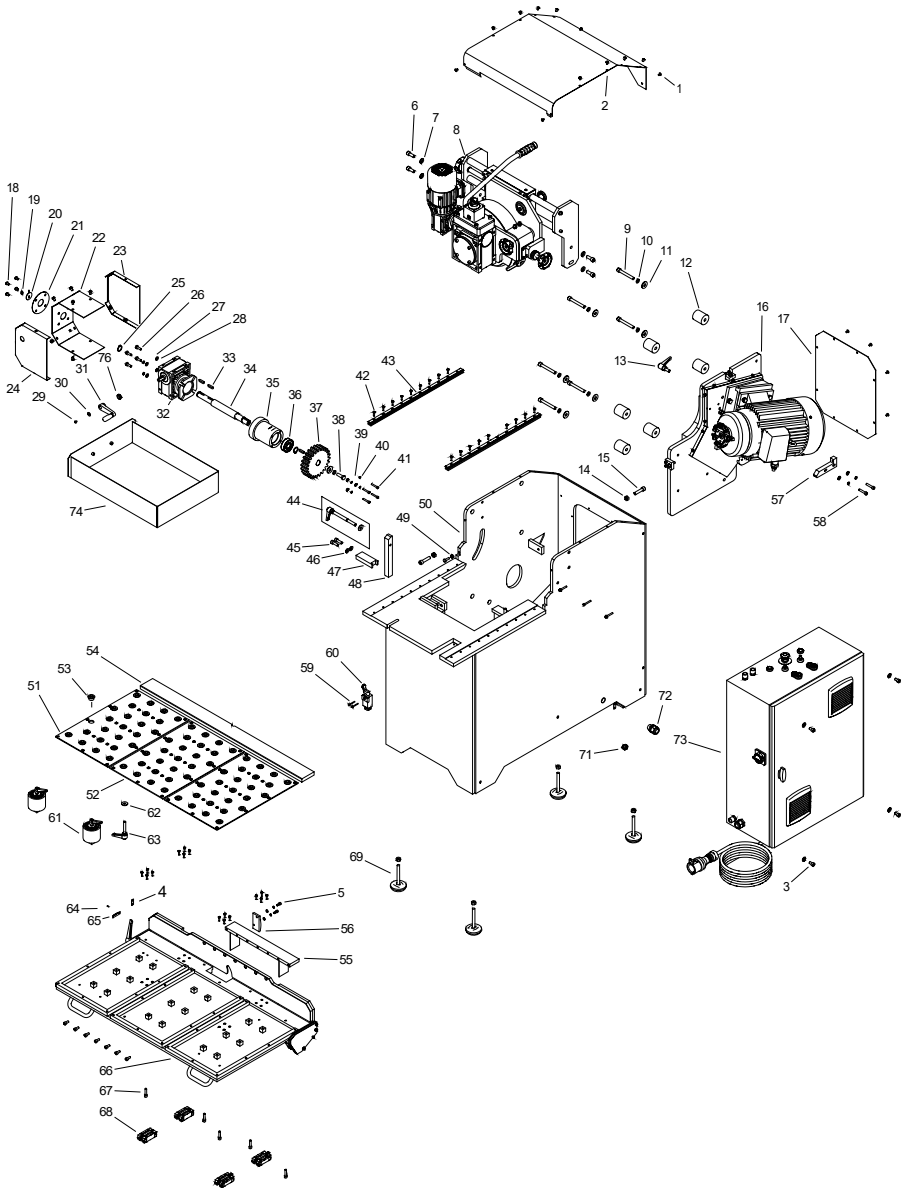

ITEM	PART NUMBER	DESCRIPTION	Q-TY
1	WKR-000336	HEX SOCKET ROUND HEAD SCREW WITH FLANGE M6x10	65
2	OSL-0573-16-00-00-1	TOP COVER	1
3	SRB-000044	HEX SOCKET HEAD CAP SCREW M10x16	4
4	UST-0573-43-00-00-0	BASE ADJUSTER	1
5	SRB-000106	HEX SOCKET HEAD CAP SCREW M6x16	2
6	SRB-000053	HEX SOCKET HEAD CAP SCREW M12x30	4

ITEM	PART NUMBER	DESCRIPTION	Q-TY
7	PDK-000118	ROUND WASHER 13	4
8	ZSP-0573-04-00-00-0	FEED ASSY	1
9	SRB-000241	HEX SOCKET HEAD CAP SCREW M12x90	6
10	PDK-000053	SPRING WASHER 12.2	7
11	PDK-000103	ROUND WASHER 13	7
12	WSP-0573-12-00-00-0	FEED ASSY SUPPORT	6
13	RKJ-000056	HANDLEVER M12-25	1
14	NKR-000003	HEX NUT M12	8
15	SRB-000214	HEX SOCKET HEAD CAP SCREW M12x50	4
16	ZSP-0573-02-00-00-0	MILLING SET ASSY	1
17	PKR-0573-07-00-00-0	COVER	1
18	WKR-000366	HEX SOCKET BUTTON HEAD SCREW M8x12	12
19	WKR-000292	HEX SOCKET BUTTON HEAD SCREW M4x6	2
20	WSK-0573-19-00-00-0	INDICATOR	1
22	OSL-0573-46-00-00-0	GEARBOX COVER	1
23	OSL-0573-22-00-00-0	LEFT GEARBOX COVER ASSY	1
24	OSL-0573-23-00-00-0	RIGHT GEARBOX COVER ASSY	1
25	PRS-000017	EXTERNAL RETAINING RING 25z	2
26	SRB-000028	FULL THREAD HEX HEAD SCREW M8x25	5
27	PDK-000051	SPRING WASHER 8.2	6
28	PDK-000022	ROUND WASHER 8.4	6
29	WKR-000058	HEX SOCKET SET SCREW WITH FLAT POINT M6x8	1
30	PDK-000037	ROUND WASHER 6.5	1
31	KBA-0573-17-00-00-0	WINCH ASSY	1
32	RDK-000010	WORM GEARBOX	1
33	WPS-000086	PARALLEL KEY 8x7x32	3
34	WLK-0573-14-00-00-0	SHAFT	1
35	OPR-0573-13-00-00-0	BEARING HOLDER	1
36	LOZ-000150	BALL BEARING 25x62x17	1
37	KOL-0573-15-00-00-0	GEAR z24	1
38	SRB-000195	FULL THREAD HEX HEAD SCREW M12x35	1
39	PDK-000021	ROUND WASHER 6.4	6
40	PDK-000046	SPRING WASHER 6.1	6
41	SRB-000123	HEX SOCKET HEAD CAP SCREW M6x35	4
42	SRB-000083	HEX SOCKET HEAD CAP SCREW M5x16	36
43	SNA-000041	GUIDE	2
44	SRB-0573-29-00-00-0	LOCKING BOLT ASSY	1
45	SRB-000047	HEX SOCKET HEAD CAP SCREW M10x30	2
46	PDK-000026	ROUND WASHER 10.5	6
47	WSP-0573-28-00-00-0	CLAMPING BLOCK SUPPORT	1
48	LPA-0573-27-00-00-0	CLAMPING BLOCK	1
49	NKR-000019	HEX NUT M8	1
50	KRP-0573-01-00-00-0	FRAME	1
51	OSL-0573-10-00-00-0	SIDE TABLE COVER	2
52	OSL-0573-11-00-00-0	CENTER TABLE COVER	1
53	RLK-000002	ROLLER	75
54	BZA-0573-08-00-00-0	HORIZONTAL BASE PLATE	1
55	ZBR-0573-03-16-00-0	VERTICAL BASE RIB ASSY	1
56	KRZ-0573-32-00-00-0	COLLISION PREVENTION CAM	1
57	ZDR-0573-33-00-00-0	COLLISION PREVENTION BUMPER	1
58	SRB-000157	HEX SOCKET HEAD CAP SCREW M8x40	2
59	WKR-000452	CROSS RECESSED PAN HEAD SCREW M4x35	2

ITEM	PART NUMBER	DESCRIPTION	Q-TY
60	LCZ-000037	LIMIT SWITCH	1
61	RLK-0573-20-00-00-0	ROLLER ASSY	2
62	PDK-000109	ROUND WASHER 10.5	1
63	RKJ-000052	HANDLEVER M10-63	1
64	NIT-000010	RIVET 2x6	4
65	LNL-0573-09-00-00-0	STRAIGHTEDGE	1
66	STL-0573-03-00-00-0	TABLE ASSY	1
67	SRB-000156	HEX SOCKET HEAD CAP SCREW M8x35	5
68	PRW-000068	CARRIAGE	4
69	STP-000023	BRACKET D75	4
71	NKR-000084	LOW HEX NUT M16x1.5	1
72	ZLC-000153	CABLE GLAND	1
73	SZF-0573-05-00-00-0	CONTROL BOX ASSY	1
74	ZBN-0573-06-00-00-0	CHIP CONTAINER ASSY	1
75*	KBL-0573-31-00-00-1	SPINDLE MOTOR WIRE SET	1
76	PDK-0573-45-00-00-0	WASHER	1

*not shown in the drawing

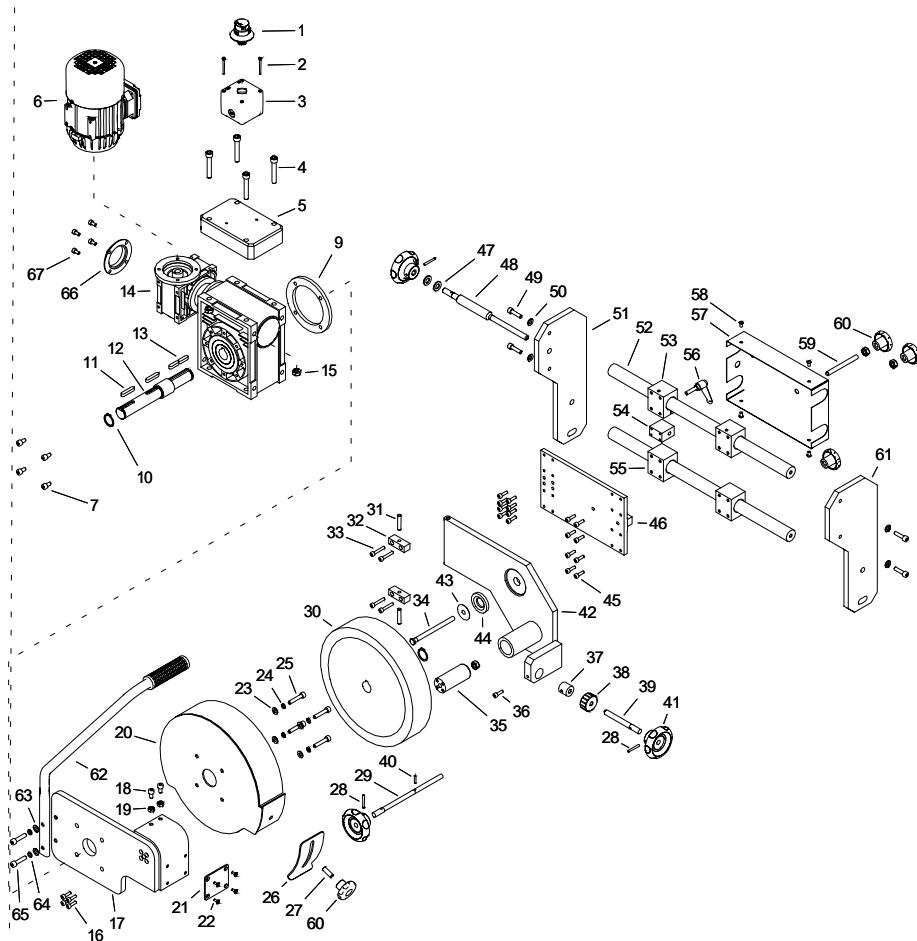

ITEM	PART NUMBER	DESCRIPTION	Q-TY
1	PRC-000029	EMERGENCY SWITCH	1
2	SRB-000067	HEX SOCKET HEAD CAP SCREW M4x40	2
3	PSZ-000005	JUNCTION BOX	1
4	SRB-000051	HEX SOCKET HEAD CAP SCREW M10x60	4
5	OBC-0573-04-19-00-0	WEIGHT	1
6	SLN-000308	MOTOR	1
7	SRB-000141	HEX SOCKET HEAD CAP SCREW M8x14	4
9	DYS-0573-04-21-00-0	GEARBOX COVER RING	2
10	PRS-000019	EXTERNAL RETAINING RING 28z	2
11	WPS-000045	KEY 8x7x40	2
12	WLK-0573-04-16-00-0	SHAFT	1
13	WPS-000077	KEY 8x7x30	2
14	RDK-000016	GEARBOX	1
15	NKR-000002	NUT M10	7
16	SRB-000114	HEX SOCKET HEAD CAP SCREW M6x20	4
17	PLY-0573-04-08-00-0	GEARBOX PLATE ASSY	1

ITEM	PART NUMBER	DESCRIPTION	Q-TY
18	SRB-000141	HEX SOCKET HEAD CAP SCREW M8x14	2
19	NKR-000019	HEX NUT M8	2
20	OSL-0573-04-24-00-0	WHEEL COVER ASSY	1
21	BLC-0573-04-27-00-0	PLATE	1
22	WKR-000134	HEX SOCKET COUNTERSUNK HEAD SCREW M5x12	4
23	PDK-000022	ROUND WASHER 8.4	4
24	PDK-000051	SPRING WASHER 8.2	4
25	SRB-000157	HEX SOCKET HEAD CAP SCREW M8x40	4
26	PON-0573-04-25-00-0	COVER LOCKING PLATE	1
27	PRT-0573-04-26-01-0	WHEEL COVER ROD	1
28	KLK-000111	DOWEL PIN 5n6x36	3
29	SRB-0573-04-13-00-0	DEPTH SETTING BOLT	1
30	KOL-0573-04-30-00-0	WHEEL	1
31	KLK-000073	DOWEL PIN 8n6x40	2
32	WSP-0573-04-18-00-0	ANGLE SETTING PLATE SUPPORT	2
33	SRB-000123	HEX SOCKET HEAD CAP SCREW M6x35	4
34	SRB-0573-04-12-00-0	ANGLE LOCKING BOLT	1
35	WLK-0573-04-10-00-0	SHAFT	1
36	SRB-000114	HEX SOCKET HEAD CAP SCREW M6x20	1
37	NKR-0573-04-23-00-0	NUT	1
38	NKR-0573-04-20-00-0	PLASTIC NUT	1
39	SRB-0573-04-15-00-0	WHEEL HEIGHT SETTING BOLT	1
40	KLK-000014	SPRING PIN 4x20	1
41	PKT-0573-03-08-00-0	KNOB	3
42	PLY-0573-04-09-00-0	ANGLE SETTING PLATE ASSY	1
43	TRC-0573-04-06-00-0	CAP	1
44	PDK-0573-04-07-00-0	SPHERICAL WASHER	1
45	SRB-000114	HEX SOCKET HEAD CAP SCREW M6x20	16
46	PLY-0573-04-05-00-1	PLATE ASSY	1
47	PDK-000118	ROUND WASHER 13	2
48	SRB-0573-04-28-00-0	BOLT	1
49	SRB-000155	HEX SOCKET HEAD CAP SCREW M8x30	4
50	PDK-000022	ROUND WASHER 8.4	4
51	WSP-0573-04-31-00-0	LEFT SUPPORT PLATE	1
52	PRT-0573-04-02-00-0	FEED SHAFT	2
53	MCW-0573-04-04-00-0	MOUNTING BLOCK - LOCK	1
54	NKR-0573-04-32-00-0	NUT	1
55	MCW-0573-04-03-00-0	MOUNTING BLOCK	3
56	RKJ-000013	HANDLEVER M8-32	1
57	OSL-0573-04-17-00-0	COVER	1
58	WKR-000100	HEX SOCKET BUTTON HEAD SCREW M6x10	4
59	SRB-0573-04-14-00-0	ANGLE SETTING BOLT	1
60	PKT-000032	KNOB D50	4
61	WSP-0573-04-01-00-0	SUPPORT PLATE	1
62	RKJ-0573-04-33-00-0	LEVER ASSY	1
63	PDK-000022	ROUND WASHER 8.4	2
64	PDK-000051	SPRING WASHER 8.2	2
65	SRB-000153	HEX SOCKET HEAD CAP SCREW M8x25	2
66	PKR-000124	COVER PCV 40	1
67	SRB-000102	HEX SOCKET HEAD CAP SCREW M6x12	4
68*	KBL-0573-04-34-00-0	FEED MOTOR CABLE	1
69	PKR-000172	COVER PCV 75	1

*not shown in the drawing

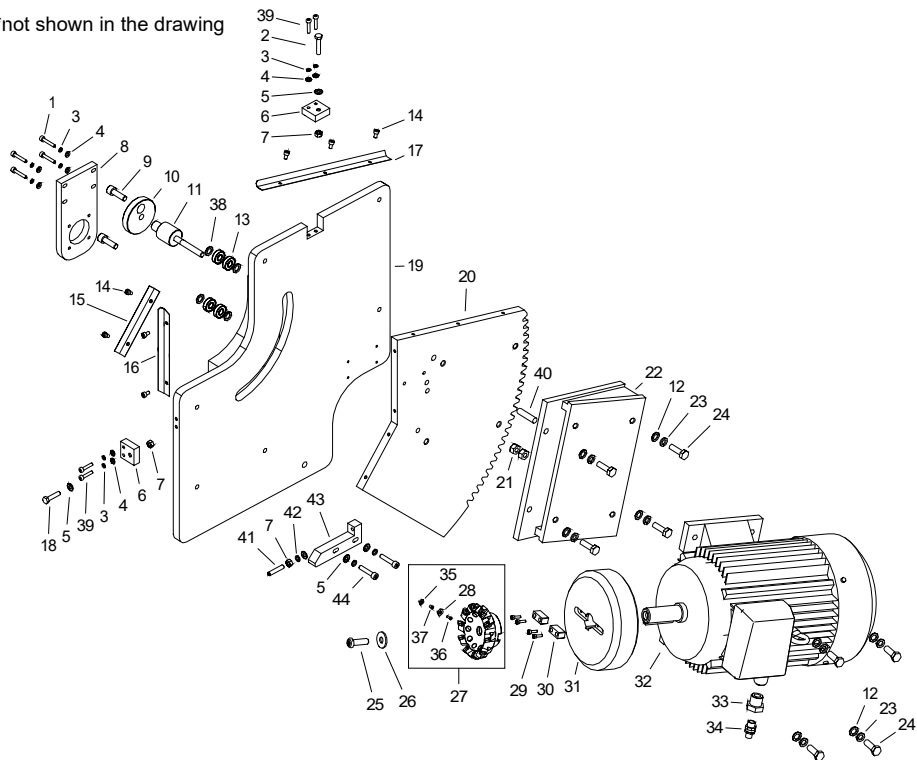

ITEM	PART NUMBER	DESCRIPTION	Q-TY
1	SRB-000123	HEX SOCKET HEAD CAP SCREW M6x35	4
2	SRB-000207	FULL THREAD HEX HEAD SCREW M8x40	1
3	PDK-000046	SPRING WASHER 6.1	8
4	PDK-000021	ROUND WASHER 6.4	8
5	PDK-000022	ROUND WASHER 8.4	5
6	BLD-0573-02-12-00-0	ANGLE LOCK PLATE	2
7	NKR-000019	HEX NUT M8	3
8	WSP-0573-02-07-00-0	GEAR SUPPORT	1
9	SRB-000308	HEX SOCKET HEAD CAP SCREW M12x35	2
10	KZK-0573-02-14-00-0	LOCKING PUCK	1
11	WLK-0573-02-15-00-0	LOCKING SHAFT	1
12	PDK-000118	ROUND WASHER 13	8
13	LOZ-000038	BALL BEARING 12x28x8	4
14	SRB-000101	HEX SOCKET HEAD CAP SCREW M6x10	7
15	ZGR-0573-02-10-00-0	CHIPS DRIFT FENDER II	1
16	ZGR-0573-02-09-00-0	CHIPS DRIFT FENDER I	1
17	ZGR-0573-02-08-00-0	TOP CHIPS DRIFT FENDER	1
18	SRB-000351	FULL THREAD HEX HEAD SCREW M8x35	1
19	PLY-0573-02-04-00-0	MOUNTING PLATE ASSY	1
20	PLY-0573-02-03-00-0	MOVING PLATE	1
21	NKR-000003	HEX NUT M12	2

ITEM	PART NUMBER	DESCRIPTION	Q-TY
22	WSP-0573-02-05-00-1	MOTOR SUPPORT	1
23	PDK-000053	SPRING WASHER 12.2	8
24	SRB-000195	FULL THREAD HEX HEAD SCREW M12x35	8
25	WKR-000509	HEX SOCKET BUTTON HEAD SCREW M12x40	1
26	PDK-000103	ROUND WASHER 13	1
27	GLW-000030	MILLING CUTTER	1
28	PLY-000396	MILLING CUTTER INSERT	10
29	SRB-000083	HEX SOCKET HEAD CAP SCREW M5x16	4
30	WPS-0573-02-02-00-0	KEY	2
31	TRC-0573-02-01-00-0	MOTOR PLATE	1
32	SLN-000304	MOTOR 400V	1
33	PRP-0573-02-06-00-0	NIPPLE	1
34	ZLC-000160	CABLE GLAND	1
35	PLY-000439	SHIM	10
36	SRB-000418	SCREW FOR CUTTING INSERT	10
37	SRB-000417	SHIM SCREW	10
38	PDK-000164	ROUND WASHER 12x18x1	4
39	SRB-000115	HEX SOCKET HEAD CAP SCREW M6x25	4
40	KLK-000097	DOWEL PIN 12n6x50	1
41	WKR-000374	HEX SOCKET SET SCREW WITH FLAT POINT M8x40	1
42	PDK-000051	SPRING WASHER 8.2	3
43	ZDR-0573-33-00-00-0	LIMIT BLOCK	1
44	SRB-000157	HEX SOCKET HEAD CAP SCREW M8x40	2

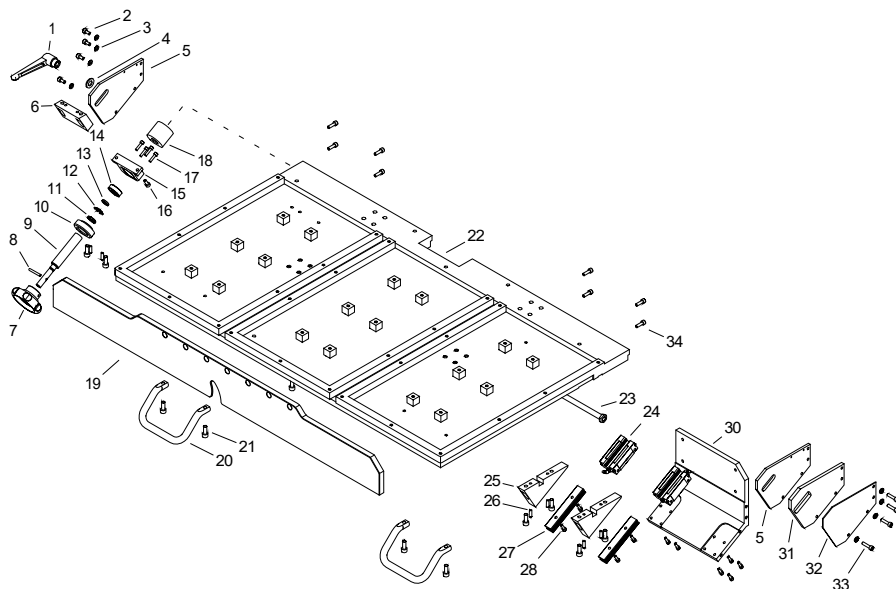

ITEM	PART NUMBER	DESCRIPTION	Q-TY
1	RKJ-000067	HANDLEVER M12	1
2	SRB-000103	HEX SOCKET HEAD CAP SCREW M6x12	4
3	PDK-000021	ROUND WASHER 6.4	8
4	PDK-000118	ROUND WASHER 13	1
5	WSP-0573-03-12-00-0	TABLE SUPPORT	2
6	WSP-0573-03-02-00-0	BEARING HOLDER SUPPORT	1
7	PKT-0573-03-08-00-0	KNOB	1
8	KLK-000111	DOWEL PIN 5n6x36	1
9	SRB-0573-03-07-00-0	BOLT	1
10	PKR-0573-03-17-00-0	BEARING COVER	1
11	NKR-000135	BEARING NUT M12x1	1
12	PDK-000179	BEARING TOOTHED WASHER MB-1	1
13	TLJ-0469-20-12-00-0	SCREW SPACER SLEEVE	1
14	LOZ-000062	BALL BEARING 12x32x10	1
15	OPR-0573-03-05-00-0	BEARING HOLDER	1
16	SRB-000106	HEX SOCKET HEAD CAP SCREW M6x16	2
17	SRB-000086	HEX SOCKET HEAD CAP SCREW M5x20	4
18	NKR-0573-03-06-00-0	NUT	1
19	BZA-0573-03-04-00-0	VERTICAL BASE PLATE	1
20	UCW-0573-03-03-00-0	HANDLE	2
21	SRB-000148	HEX SOCKET HEAD CAP SCREW M8x20	12
22	STL-0573-03-01-00-1	TABLE	1
23	PRT-0573-03-13-00-0	LOCKING ROD ASSY	1
24	PRW-000068	CARRIAGE	3
25	WSP-0573-03-09-00-0	GUIDE SUPPORT	3
26	KLK-000083	DOWEL PIN 6n6x18	8
27	SNA-000040	GUIDE	3
28	SRB-000083	HEX SOCKET HEAD CAP SCREW M5x16	22

ITEM	PART NUMBER	DESCRIPTION	Q-TY
29*	WSP-0573-03-10-00-1	LEFT VERTICAL BASE SUPPORT	1
30	WSP-0573-03-11-00-1	RIGHT VERTICAL BASE SUPPORT	1
31	BLD-0573-03-14-00-0	NUT LOCK	1
32	OSL-0573-03-15-00-0	NUT COVER	1
33	SRB-000115	HEX SOCKET HEAD CAP SCREW M6x25	4
34	SRB-000114	HEX SOCKET HEAD CAP SCREW M6x20	8

*not shown in the drawing

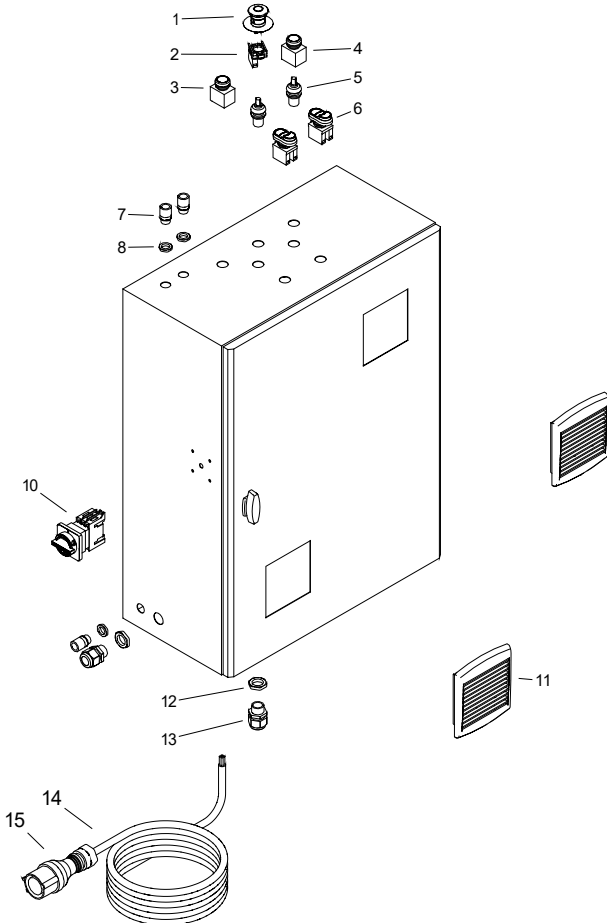

ITEM	PART NUMBER	DESCRIPTION	Q-TY
1	PRC-000029	EMERGENCY BUTTON	1
2	STK-000010	CONNECTOR	1
3	PRC-000042	GREEN BUTTON	1
4	PRC-000043	RED BUTTON	1
5	PTN-000038	POTENTIOMETER	2

ITEM	PART NUMBER	DESCRIPTION	Q-TY
6	PRC-000044	START-STOP BUTTON	2
7	PRP-000014	STRAIN RELIEF	3
8	NKR-000198	STRAIN RELIEF NUT M20x1.5	3
9	SZF-0573-05-01-00-0	CONTROL BOX	1
10	RZL-000020	3-GEAR DISCONNECTOR 40A	1
11	FLT-000031	AIR FILTER	2
12	NKR-000165	STRAIN RELIEF NUT M25x1.5	2
13	DLW-000045	CABLE GLAND M25x1.5	2
14	KBL-000173	CABLE	1
15	WTK-000032	MALE SOCKET	1
16*	KBL-0573-05-02-00-0	EMERGENCY BUTTON WIRE SET	1
17*	KBL-0573-05-03-00-0	TABLE EMERGENCY BUTTON WIRE SET	1

*not shown in the drawing

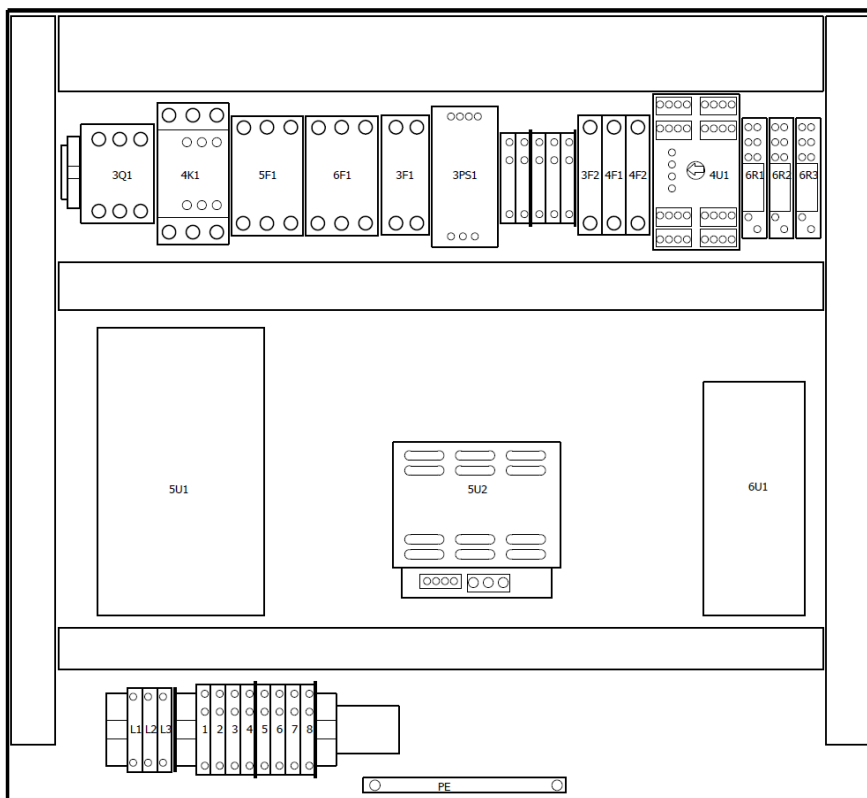

ITEM	PART NUMBER	DESCRIPTION	Q-TY
3Q1	RZL-000020	3-GEAR DISCONNECTOR 40A	1
3Q1	OSL-000255	COVER	1
4K1	STY-000010	CONTACTOR 32A	1
5F1	BZP-000041	CIRCUIT BREAKER C25	1
6F1	BZP-000031	CIRCUIT BREAKER C6	1

ITEM	PART NUMBER	DESCRIPTION	Q-TY
3F1	BZP-000027	CIRCUIT BREAKER C6	1
3PS1	ZSL-000027	POWER SUPPLY	1
3F2	BZP-000019	CIRCUIT BREAKER B1	1
4F1	BZP-000019	CIRCUIT BREAKER B1	1
4F2	BZP-000019	CIRCUIT BREAKER B1	1
4U1	PZK-000044	EMERGENCY STOP MODULE	1
6R1	PDS-000024	SOCKET	1
6R1	PZK-000030	RELAY 24VDC	1
6R2	PDS-000024	SOCKET	1
6R2	PZK-000030	RELAY 24VDC	1
6R3	PDS-000024	SOCKET	1
6R3	PZK-000030	RELAY 24VDC	1
5U1	PRZ-0573-99-00-00-0	SPINDLE FREQUENCY INVERTER 3x400V	1
5U2	MDL-000083	DYNAMIC BRAKING MODULE	1
6U1	PRZ-0573-99-10-00-0	FEED FREQUENCY INVERTER 3x400V	1

LIMITED WARRANTY

Industrial Tool & Machinery Sales (hereinafter referred to as ITMS) will, within twelve (12) months from the original date of purchase, repair or replace any goods found to be defective in materials or workmanship.

This warranty is void if the item has been damaged by accident, neglect, improper service or other causes not arising out of defects in materials or workmanship.

This warranty does not apply to machines and/or components which have been altered, changed, or modified in any way, or subjected to overloading or use beyond recommended capacities and specifications. Worn componentry due to normal wear and tear is not a warranty claim. Goods returned defective shall be returned prepaid freight to ITMS or agreed repair agent, which shall be the buyer's sole and exclusive remedy for defective goods. ITMS accepts no additional liability pursuant to this guarantee for the costs of travelling or transportation of the product or parts to and from ITMS or the service agent or dealer, such costs are not included in this warranty.

Our goods come with guarantees which cannot be excluded under the Australian Consumer Law. You are entitled to replacement or refund for a major failure and to compensation for other reasonably foreseeable loss or damage. You are also entitled to have the goods repaired or replaced if the goods fail to be of acceptable quality and the failure does not amount to a major failure.

THE MANUFACTURER RESERVES THE RIGHT TO MAKE IMPROVEMENTS AND MODIFICATIONS TO DESIGN WITHOUT PRIOR NOTICE.

PRODUCTS IMPORTED AND DISTRIBUTED NATIONALLY BY:



INDUSTRIAL TOOL & MACHINERY SALES

11 EASTERN SERVICE ROAD, STAPYLTON, QLD, 4207

T: 07 3287 1114 E: sales@industrialtool.com.au

F: 07 3287 1115 W: www.itmtools.com.au

